

Preventative Maintenance for HVL™ Load Interrupter Switches Class 6040

Retain for future use.

INTRODUCTION

Medium voltage HVL™ load interrupter switches are used in installations where reliable but infrequent load break switching is required. Load interrupter switches are often required to operate in harsh environments and are subject to moisture, particulates, abrasive and corrosive materials, and a wide range of temperatures. Additionally, long periods of time may pass between switching operations. Load interrupter switches require appropriate preventative maintenance to ensure continuous and proper operation. The three primary components of preventative maintenance are:

- A regularly scheduled maintenance program
- Correct maintenance procedures
- Qualified maintenance personnel

Some factors may make it necessary to schedule preventative maintenance more frequently than would otherwise be required. These factors include adverse operating environments and the severity and frequency of switching. Also, while maintenance scheduling will depend on the availability of downtime and qualified personnel, some abnormal conditions may require immediate attention.

Switch Operation

Square D's and most other manufacturers' HVL load interrupter switches employ an electrical design where the contact for each phase consists of main contacts set parallel to a spring loaded arcing blade. The arcing blade opens after the main contacts to allow the arcing blade to interrupt the load current.

Figure 1: Square D HVL load interrupter switch operation

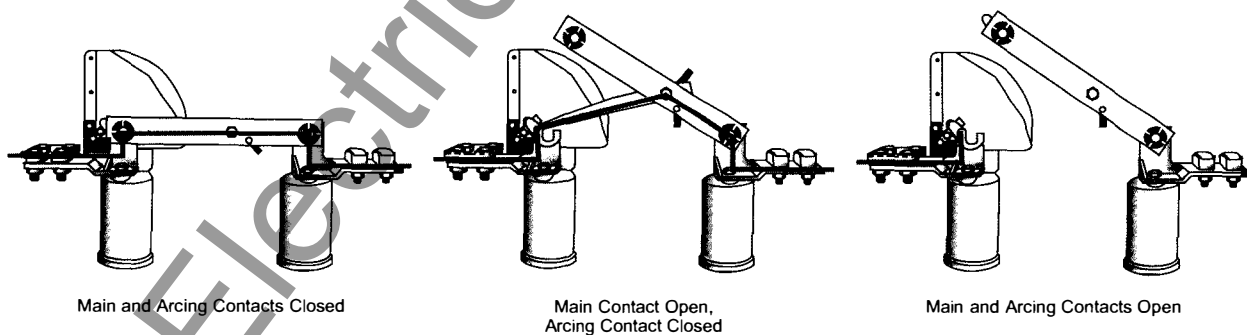

www.ElectricalPartManuals.com

MAINTENANCE SCHEDULE

Square D recommends inspecting medium voltage HVL™ load interrupter switches once a year or every 100 operations, whichever comes first. The switch should be inspected at the earliest opportunity if it carries heavy fault currents, frequently interrupts load currents, or experiences other stressful conditions.

It may be necessary to inspect the switch more than once a year if the switch is located in a corrosive, dusty, or humid area or if it is often exposed to extremely high or low temperatures. Failure to complete frequent preventative maintenance for a switch in any of these circumstances may reduce the switch's effective lifetime. For example, exposure to a corrosive environment may cause a non-conductive contaminant to collect on exposed electrical parts that will lead to an increase in contact resistance, and consequently to thermal runaway. Exposure to a humid environment may produce a conductive path on electrical insulation that could lead to tracking, and eventually to insulation flashover. In an environment contaminated with dust and particulate matter, heavy deposits may form on the switch's moving parts and contacts that could hinder proper operation. It is extremely important to consider environmental conditions when establishing a preventive maintenance schedule.

GENERAL MAINTENANCE PROCEDURES

Follow the manufacturer's service recommendations concerning inspection and maintenance found in the switch's instruction bulletin. It details the necessary tests to perform during inspection to determine the condition of the switch's mechanical and electrical parts. It explains required lubrication as well as any mechanical adjustments that may need to be made. It also lists part numbers so that any parts found to be worn, damaged or broken can be replaced.

Most manufacturers recommend testing insulation by performing a standard 60-cycle, one-minute Hi-Pot test. If the insulation flashes over, a problem exists that, usually, can be corrected by cleaning the insulators. Most manufacturers recommend re-tightening the hardware to required torque values if discoloration or any other symptom of overheated connections is observed.

Supplementary devices such as meters and relays should be maintained according to the specific instructions given in their respective instruction bulletins. Control wiring should be checked for signs of physical damage or overheating and wiring connections should be checked for tightness. Damaged wiring should be replaced immediately.

All dust, dirt, and grime should be cleaned from insulators, barriers, busses, connections, enclosure surfaces, and the operating mechanism during regular preventative maintenance. This cleaning helps to prevent insulation flashover and keeps contaminants from getting into the switch's main contacts and potentially causing them to stick closed or to overheat. Cleaning and lubrication of electrical and mechanical parts should be performed according to the guidelines given in the switch's instruction bulletin. The switch should be operated several times manually after cleaning and lubrication to verify that it is operating properly.

www.ElectricalPartManuals.com

Maintenance of Load Interrupter Switches

Special attention should be paid to ensure proper lubrication of the main contacts and the switch's operating mechanism. The main or arcing contacts can stick closed if the contacts and the operating mechanism are not cleaned and lubricated properly.

The unique application conditions for load interrupter switches make using the correct lubricants very important. Using incorrect lubrication procedures or products can render the switch inoperable. The switch's instruction bulletin defines lubrication points, appropriate lubrication products for specific locations, and maintenance intervals.

SQUARE D MAINTENANCE AND LUBRICATION RECOMMENDATIONS FOR HVL LOAD INTERRUPTER SWITCHES

⚠ DANGER

Before performing any inspection, maintenance or parts replacement:

- Disconnect all sources of electric power. Assume all circuits are live until they are completely de-energized, tested, grounded, and tagged. Pay particular attention to the design of the power system. Consider all sources of power, including the possibility of backfeeding.
- Use a properly rated voltage sensing device to confirm the power is OFF.
- Be aware of potential hazards; wear personal protective equipment, and take adequate safety precautions. Ensure compliance with NFPA 70 E - Standard for Electrical Safety Requirements for Employee Workplaces and OSHA Standards - 29 CFR Part 1910 Subpart S - Electrical.

Failure to follow these instructions will result in equipment damage, serious personal injury, or death.

If the arcing blade tip is severely burned, the contacts and arc chute assembly should be replaced. Occasionally, the main blade and jaw should be wiped clean to remove accumulated grime and then re-lubricated.

Lubrication of Main Contacts

Clean the main blade and jaw contact areas with an electrical contact cleaner and then re-lubricate them with a light film of Mobilgrease 28 as indicated in Figure 3. Do not lubricate the jaw contact tips or the arc chute assembly.

Lubrication of Mechanism

Wipe the mechanism clean and then lubricate with Mobilgrease 28 as indicated in Figure 2. The main shaft bearings do not require additional lubrication. Do not disassemble the mechanism.

Figure 2: Mechanism lubrication points

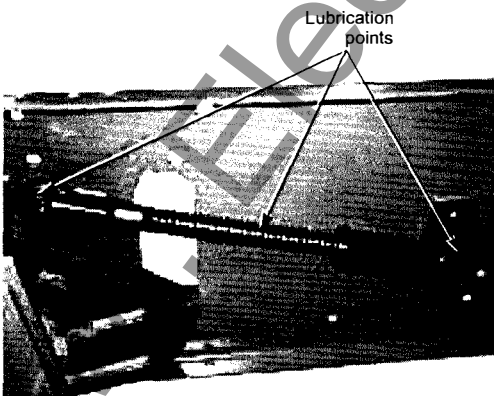
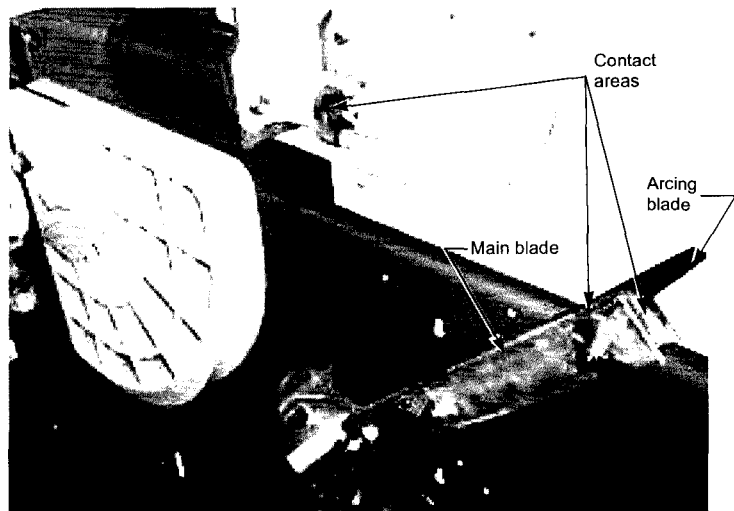

Figure 3: Main contact lubrication points



www.ElectricalPartManuals.com

HVL Load Interrupter Switch Safety Features

Square D's HVL™ load interrupter switches feature a viewing window that allows visual verification that both the main and arcing contacts are fully opened prior to working on the switch or circuit.

As an optional feature, a set of live line indicator LED lights can be added to HVL equipment. These indicators will glow as long as any voltage remains on a bus; one LED per phase energized by capacitor dividers on the medium voltage bus. Contact Square D if you would like to have these live line indicator LED lights installed on your switchgear. However, these indicators are no substitute for safe working practices. All appropriate safety precautions should be followed before any maintenance work is performed.

Figure 4: Viewing window

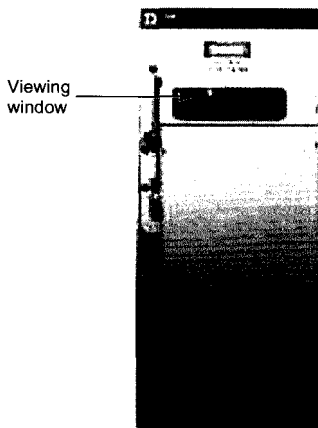
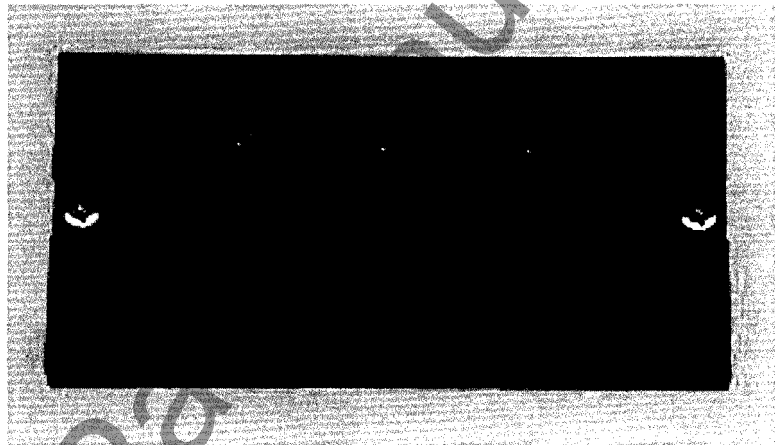

Figure 5: LED live line indicators



PERSONNEL QUALIFICATION

It is imperative that only qualified personnel work on electrical equipment. All maintenance personnel should meet the minimum training requirements set forth in NFPA 70E - Standard for Electrical Safety Requirements for Employee Workplaces.

Appropriate maintenance personnel training, a strict adherence to established safety procedures, and regular inspection and maintenance will increase the life span and reliability of most HVL load interrupter switches.

Square D Company
9870 Crescent Park Drive
West Chester, OH 45069 USA
1-888-SquareD (1-888-778-2733)
www.SquareD.com

Electrical equipment should be installed, operated, serviced, and maintained only by qualified personnel. No responsibility is assumed by Schneider Electric for any consequences arising out of the use of this material.



SQUARE D

© 2002 Schneider Electric All Rights Reserved

www.ElectricalPartManuals.com