

**Auxiliary Switch**  
**Disparador de Apertura**  
**Déclencheur à émission de courant**

Item: ASKE2  
 ASKE3  
 For Use With Frame EG  
 Para Usar Con Caja Base EG

Installation Instructions / Instructivo de Instalación

	<b>⚠ Danger</b>	<b>⚠ Peligro</b>	<b>⚠ Danger</b>
	<p><b>Hazardous Voltage.</b>  <b>Will cause death or serious injury.</b></p> <p>Turn off and lock out all power supplying this device before working on this device.                  Replace all covers before power supplying this device is turned on.</p>	<p><b>Tensión peligrosa.</b>  <b>Puede causar la muerte o lesiones graves.</b></p> <p>Desenergice totalmente antes de instalar o darle servicio.                  Reemplace todas las barreras y cubiertas antes de energizar el interruptor.</p>	<p><b>Tension dangereuse.</b>  <b>Danger de mort ou risque de blessures graves.</b></p> <p>Couper l'alimentation de l'appareil et barrer avant de travailler.                  Remplacez tous les couverts avant que l'alimentation de pouvoir soit alimenté.</p>

Use only with Siemens certified components.  
 Utilizar únicamente con componentes certificados de Siemens.  
 A utiliser uniquement avec les composants certifiés Siemens.

Maximum Voltage [Maximo Voltaje] (Ue)	Frequency [Frecuencia] (~)	Maximum Current [Maxima Corriente] (In)
600 V	50/60 Hz	2 A
125 / 250 V	50/60 Hz	5 A
125 V	DC (V ---)	1 A

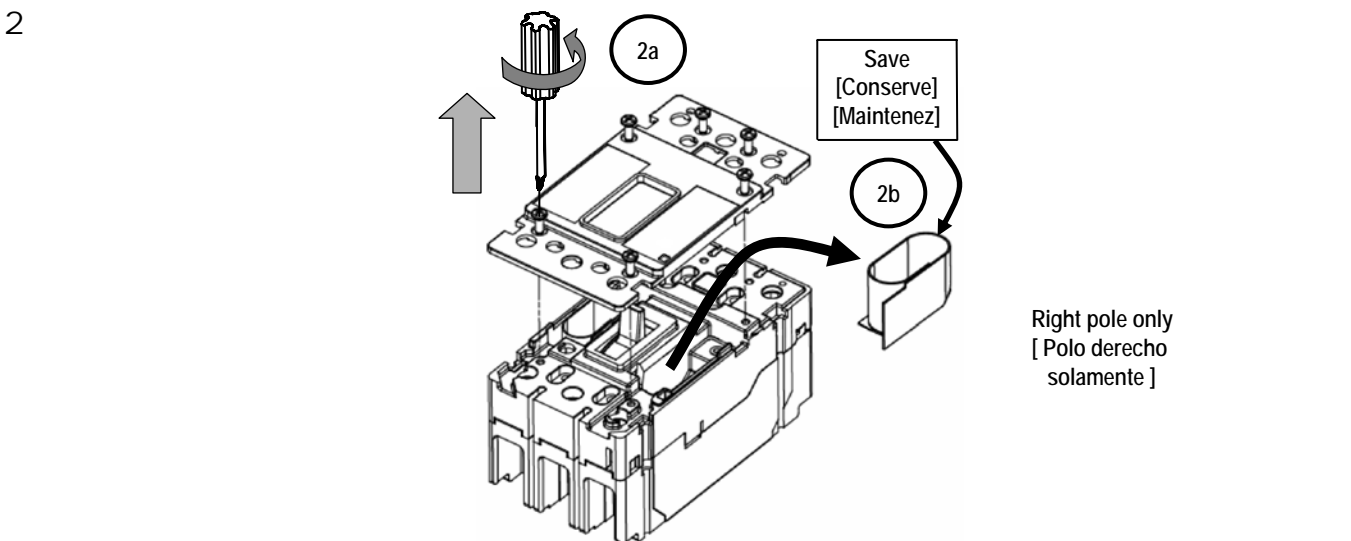
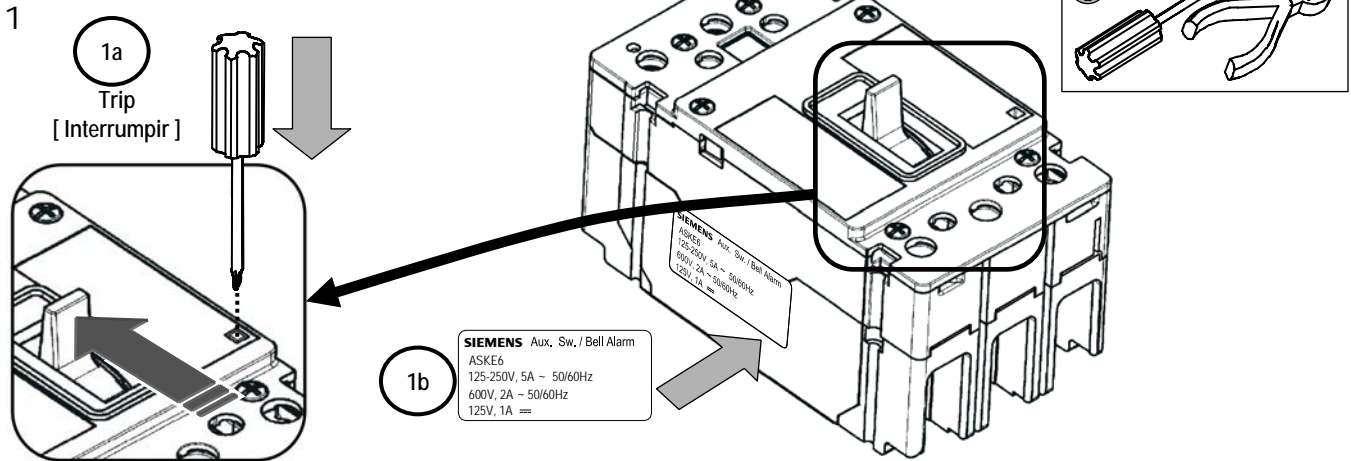
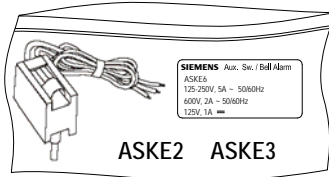

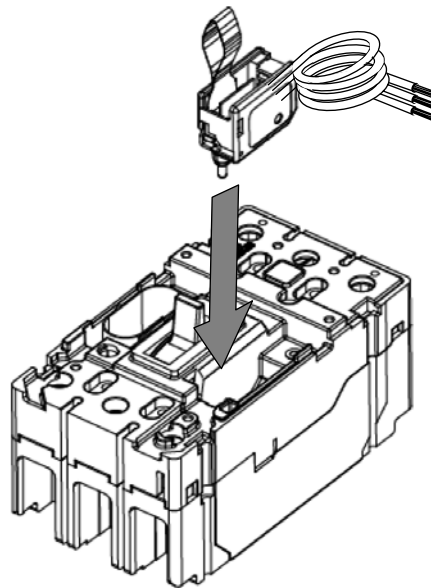

3

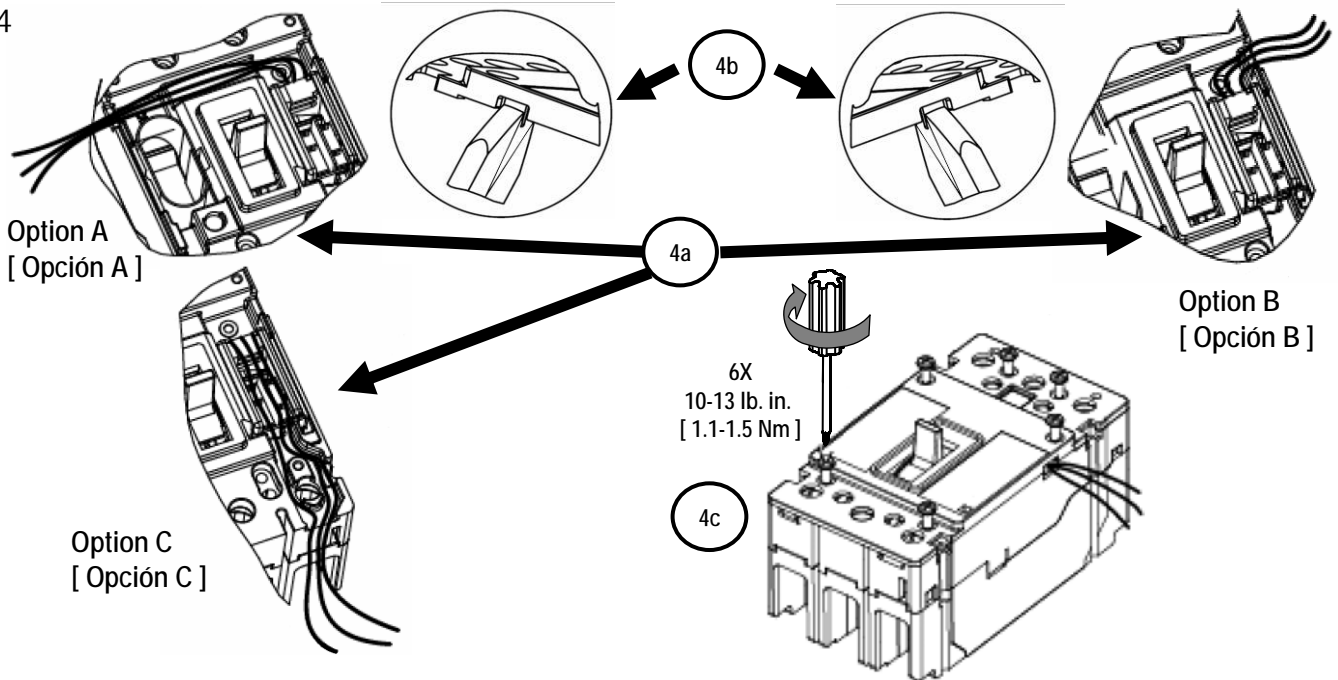

Right pole only  
[ Polo derecho solamente ]

4

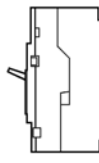
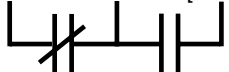

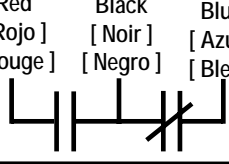
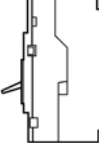
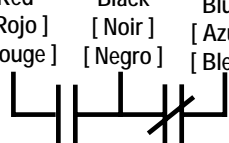
Auxiliary Switch [ Interruptor Auxiliar ]	ON / I		Red [ Rojo ] [ Rouge ] Black [ Noir ] [ Negro ] Blue [ Azul ] [ Bleu ]	
	Trip [ Interrumpir ]		Red [ Rojo ] [ Rouge ] Black [ Noir ] [ Negro ] Blue [ Azul ] [ Bleu ]	
	OFF / O		Red [ Rojo ] [ Rouge ] Black [ Noir ] [ Negro ] Blue [ Azul ] [ Bleu ]	



### **Danger**

**Hazardous Voltage.**  
Will cause death or serious injury.

Turn off and lock out all power supplying this device before working on this device.  
Replace all covers before power supplying this device is turned on.

### **Peligro**

**Tensión peligrosa.**  
Puede causar la muerte o lesiones graves.

Desenergice totalmente antes de instalar o darle servicio.  
Reemplace todas las barreras y cubiertas antes de energizar el interruptor.

### **Danger**

**Tension dangereuse.**  
Danger de mort ou risque de blessures graves.

Couper l'alimentation de l'appareil et barrer avant de travailler.  
Remplacez tous les couverts avant que l'alprovisionnement de pouvoir soit alimenté.

## Removal [ Remover ]

