

# ASCO

## Group 9 Control Panel Instruction Manual

[www.ElectricalPartsmannuals.com](http://www.ElectricalPartsmannuals.com)

# TABLE OF CONTENTS

	page
Installation.....	1-3
Functional Test .....	4-5
Preventive Maintenance .....	5
Trouble-Shooting.....	6
Manual Load Transfer .....	7
Sequence of Operation .....	8
Adjustments .....	9-11
Optional Accessories.....	12-15
Diagrams .....	back of manual
ASCO Service Centers.....	inside back cover

## IMPORTANT!

**CAUTION:** *is used in this manual to warn of possible equipment damage.*

**WARNING:** *is used in this manual to warn of possible personal injury.*

---

## INSTALLATION

ASCO automatic transfer switches are factory wired and tested. Installation simply requires mounting, and connection of service cables, engine start signal wires, and auxiliary control circuits (if required).

### Mounting

Four *Composite Outline and Mounting Diagrams* are furnished at the back of this manual. Use diagram JS 345-543 for enclosed switches. The other three drawings are for open-type switches: Use diagram JS 345-538 for 30-400 ampere switches, JS 345-539 for 600-4000 ampere switches without Acc. 28, and JS 345-540 for 600-4000 ampere switches with Acc. 28. The diagrams show all mounting details and instructions.

**CAUTION:** *Protect the switch from construction grit and metal chips.*

Mount the automatic transfer switch vertically to a rigid supporting structure. Level all mounting points by using flat washers behind the holes to avoid forced distortion of the transfer switch.

Mount open-type 400 ampere transfer switches on the supplied insulator backing piece. It must be installed behind the transfer switch. See Figure 1.

**WARNING:** Be sure to install the insulator piece behind the 400 amp transfer switch.

## INSTALLATION (continued)

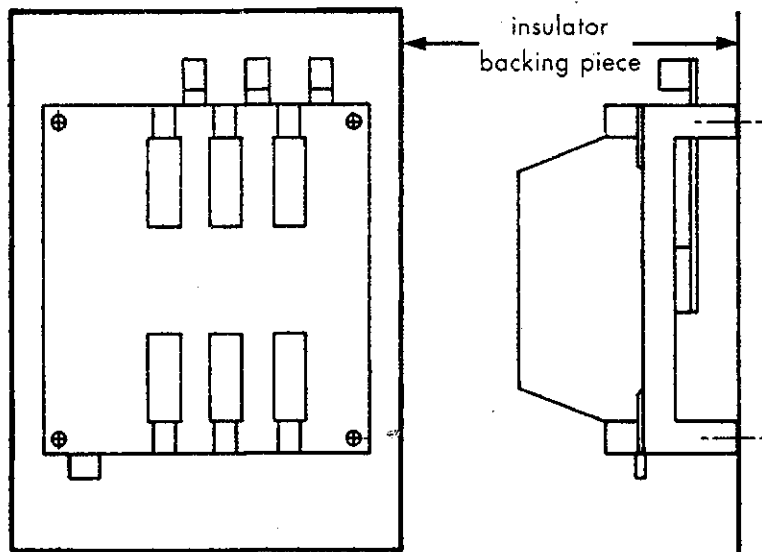

Figure 1. Backing piece for 400 ampere

Enclosed switches have the control panel mounted on the cabinet door. For open-type switches, mount the control panel to the right of the transfer switch, preferably on the inside surface of the enclosure door.

An add-on panel may be provided for certain optional accessories. It is mounted below the control panel. For open-type switches only, the control panel and add-on panel are supplied on mounting rails. Refer to the *Composite Outline and Mounting Diagrams* for details.

**WARNING:** Do not make any line or auxiliary circuitry connections before de-energizing the normal source branch to be connected to the transfer switch. Also place the standby engine starting control in the *off* position.

### Line Connections

Two *Composite Elementary Wiring Diagrams* are furnished at the back of this manual. Use diagram JS 345-541 for 3 pole transfer switches or diagram JS 345-542 for 2 pole transfer switches.

All power cables should enter enclosure adjacent to the transfer switch terminals. Pilot knockouts are provided on NEMA Type 1 and 2 enclosures. Protect the transfer switch from metal chips and construction grit at all times. Standard terminal lugs are solderless screw type and will accept the wire sizes listed on the *Composite Outline and Mounting Diagrams* furnished at the back of this manual.

Three Cable Spacers are included with 150 ampere ASCO 940 transfer switches. When installing power cables, run the cables through the Cable Spacers as shown in Figure 2. Position the Cable Spacers within 1½ inches from the terminal lugs.

**CAUTION:** *The Cable Spacers must be located as shown for 150 amp Transfer Switches.*

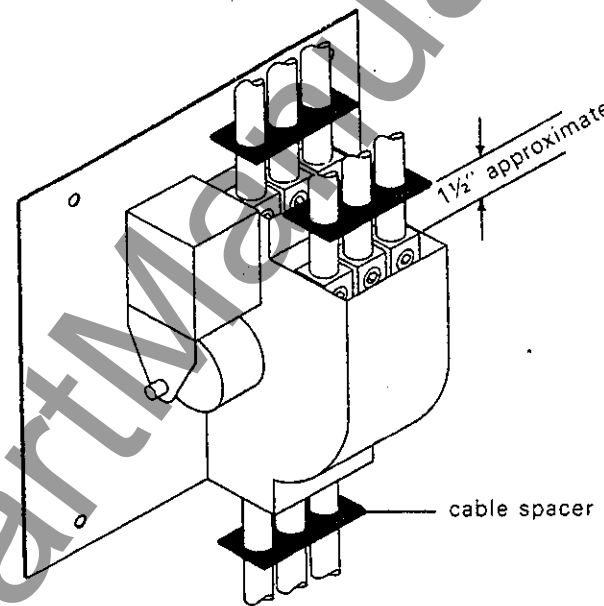

Figure 2. Cable spacers for 150 ampere

Do not run cables behind the transfer switch. Cables can be bundled to the side of the switch. Maintain proper electrical clearance between the live metal parts and grounded metal: ½" minimum for 30-400 amps, 1" minimum over 400 amps.

It is not necessary to remove the barriers from the transfer switch. If you do remove them, however, reinstall them carefully.

Connect source and load conductors to clearly marked transfer switch terminal lugs. Be careful when stripping insulation from cables; avoid nicking or ringing the conductor. Remove surface oxides from cables by cleaning with a wire brush. When aluminum conductor is used, apply joint compound to conductor, then carefully wipe away excess compound. Tighten the cable lugs to the torque specified in Table A.

# INSTALLATION (continued)

Table A. Tightening torque values for socket-head screw connectors.

Socket Size across flats in inches	Tightening Torque in inch pounds
1/8	45
5/32	100
3/16	120
7/32	150
1/4	200
5/16	275
3/8	375
1/2	500
9/16	600

Note any optional accessories that may be furnished on this switch. Make the necessary auxiliary connections by referring to pages 12, 14, and any separate drawings and/or publications that may be packed with the switch.

### Auxiliary Circuits

Connect auxiliary circuit wires to appropriate terminals on the automatic transfer switch. External circuits can include auxiliary contacts on the transfer switch, signal lamps, test switch, and optional accessories. The test switch and signal lamps are already installed and wired on enclosed automatic transfer switches. For open-type switches the test switch and lamps are supplied loose.

### Harnesses

All internal connections are made at the factory. The transfer switch and the control panel have their own wire harness. The two harnesses are joined together by the in-line disconnect plug. Extension harnesses are available in standard lengths. The plug is already engaged on enclosed automatic transfer switches. For open-type switches, the plug must be engaged after installation is completed. Carefully align the plug halves and push them straight together until the latches click. Do not roll the plug together.

### Engine Starting Contacts

The engine control contact connections are located on the transfer switch. Connect signal wires to appropriate terminals as specified in Table B and shown in Figures 3A and 3B.

Table B. Engine start connections.

Feature	When normal source fails	Terminals on transfer switch
7	contact closes	TB14 and TB15
8	contact opens	TB14 and TB16

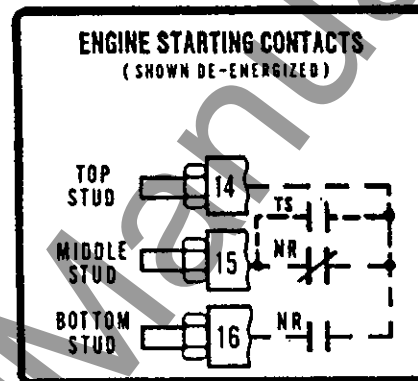
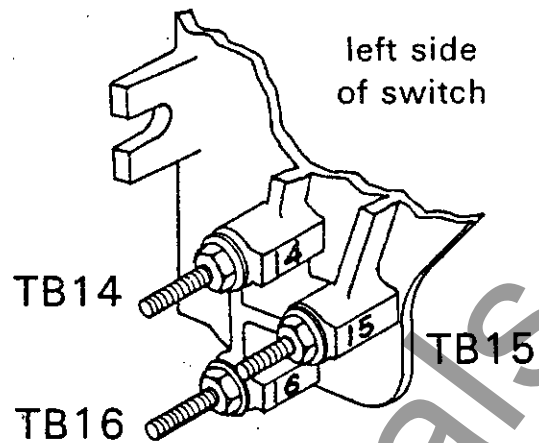

Figure 3A. Engine starting contact label and location for 30-150 amp switches.

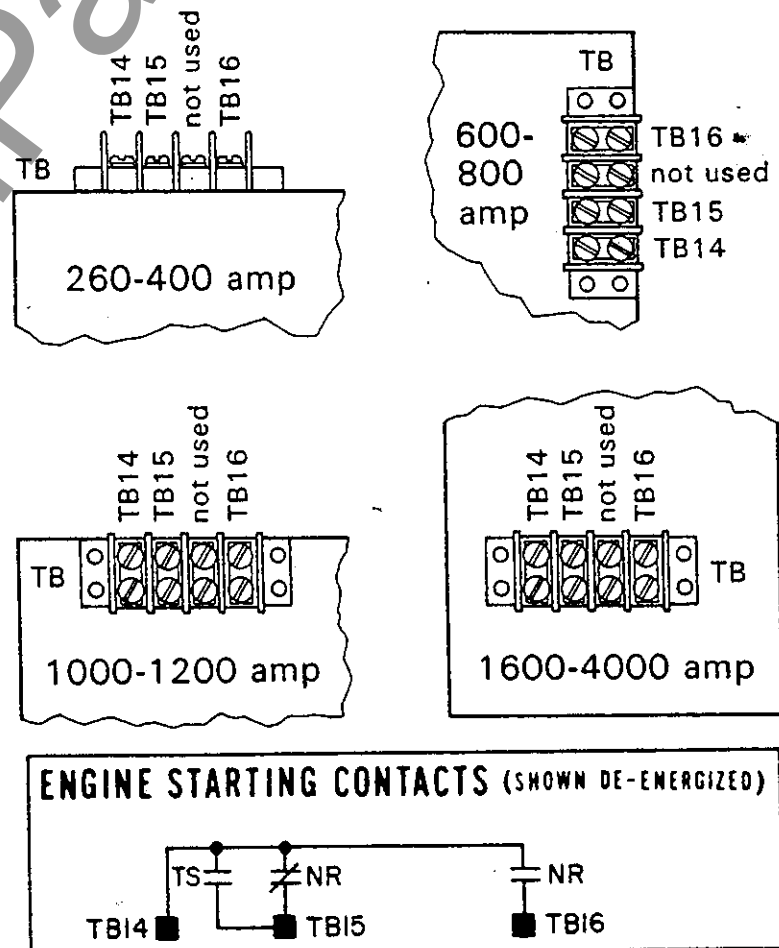

Figure 3B. Engine starting contact label and locations for 260-4000 amp switches.

## FUNCTIONAL TEST

The Functional Test consists of three checks: manual operation, voltage checks, electrical operation.

**CAUTION:** Do these checks in the order presented to avoid damaging the switch.

Read and understand all instructions on the Composite Elementary Wiring Diagram and on labels affixed to the automatic transfer switch. Note any optional accessories that are provided with this switch, and review their operation before proceeding.

### Manual Operation

A manual operator handle (detachable on 260 through 4000 ampere sizes) is provided on the transfer switch for maintenance purposes only. Manual operation of the switch must be checked before it is operated electrically.

**WARNING:** Do not manually operate the transfer switch until both power sources are disconnected: Open both circuit breakers.

1. Select the appropriate switch amperage size below and follow the directions for installing the handle:

#### *30 through 150 ampere*

Grasp the manual handle (left side of operator) and turn it with thumb and fingers. See Figure 4.

#### *260 and 400 ampere*

Insert the manual handle into the hole in the shaft, left side of the operator. See Figure 5.

#### *600 and 800 ampere*

Attach the manual handle onto the pivot shaft extension, left side of the operator. See Figure 6.

#### *1000 through 4000 ampere*

Insert the manual handle into the hole in the rotating weight. See Figure 7.

2. Move the handle as shown to manually operate the transfer switch. The switch should operate smoothly without binding. If it does not, check for shipping damage or construction debris.
3. Return the transfer switch to the normal position. Remove the manual handle, (if detachable) and store it on the transfer switch in the place provided.

Continue the Functional Test on page 5.

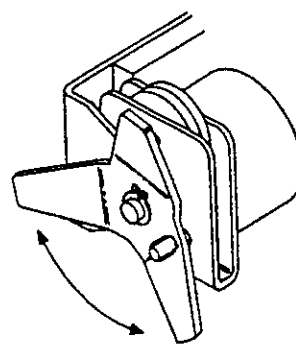

Figure 4. 30 - 150 ampere

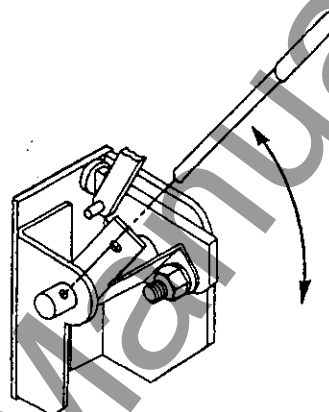

Figure 5. 260 - 400 ampere

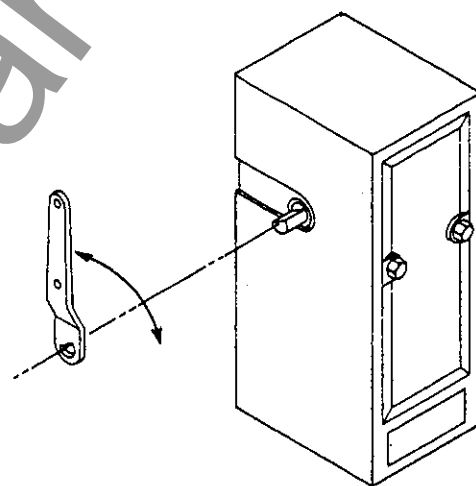

Figure 6. 600 - 800 ampere

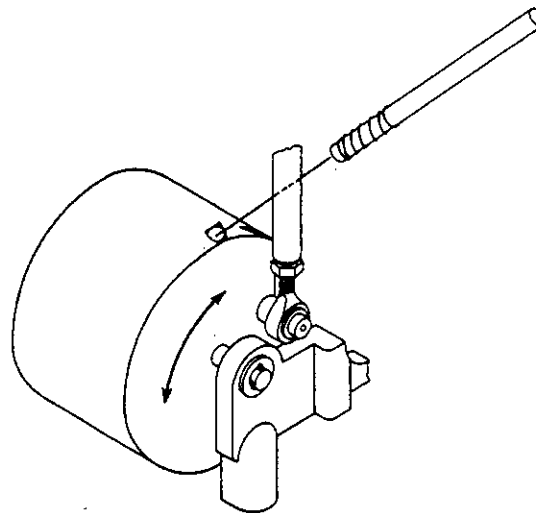

Figure 7. 1000-4000 ampere

**ASCO** Controls are designed and manufactured by **Automatic Switch Co.**  
Florham Park, New Jersey 07932, Telephone (201) 966-2070

© Automatic Switch Co. MCMXXXIV. All Rights Reserved.

For further service information,  
contact your nearest ASCO source.

## FUNCTIONAL TEST (continued)

### Voltage Checks

First check the nameplate on the transfer switch for rated voltage. It should be the same as the normal and emergency line voltages.

**WARNING:** The switch will be energized now. Proceed with care! The transfer switch should be in the *Normal* position.

1. Close the normal source circuit breaker.
2. Use an accurate voltmeter to check the phase to phase and phase to neutral voltages present at the transfer switch normal source terminals.
3. Close the emergency source circuit breaker. Then manually start the engine generator at the set.
4. Use an accurate voltmeter to check the phase to phase and phase to neutral voltages present at the transfer switch emergency source terminals.

If necessary, adjust the voltage regulator on the generator according to the manufacturer's recommendations. The automatic transfer switch will respond only to the rated voltage and frequency specified on the nameplate.

5. Shut down the engine generator. Then put the starting control in the *automatic* position.

### Electrical Operation

The following procedure will check the electrical operation of the automatic transfer switch.

#### *Transfer Test*

1. Operate and hold the door-mounted *Transfer Test* switch until the engine starts and runs. This should happen within 15 seconds.
2. The transfer switch will operate to the *Emergency* position. If Feature 2B is used, the transfer will occur after a time delay (up to 1 minute).
3. The transfer switch will operate back to the *Normal* position after Feature 3A time delay (up to 30 minutes).
4. Feature 2E allows the engine to continue to run for an additional unloaded running time (up to 5 minutes).

This completes the Functional Test of the automatic transfer switch. The engine generator's starting control should be left in the *automatic* position.

## PREVENTIVE MAINTENANCE

Reasonable care in preventive maintenance will insure high reliability and long life for the automatic transfer switch.

### Operate the switch at least once a month.

Perform the four step *Transfer Test* above to check the electrical operation of the switch. Because the test switch only simulates failure of the normal source, service is interrupted only during the actual transfer of the load.

### Clean and inspect the switch once a year.

De-energize all sources, then brush and vacuum away any excessive dust accumulation. Leave the cover on the control panel. Remove the transfer switch barriers and check the condition of the contacts. Replace contacts when pitted or worn excessively. Reinstall the barriers carefully.

### Maintain transfer switch lubrication.

The transfer switch has been properly lubricated, and under normal operating conditions no further lubricating is required. Renew factory lubrication if the switch is subjected to severe dust or abnormal operating conditions. Relubricate the operator if TS coil is replaced. Order *lubrication kit 75-100*.

### Replacement parts.

Main contacts and the TS operator coil are available in kit form. When ordering parts provide the Serial No. and Catalog No. from the transfer switch nameplate. Contact your local ASCO Authorized Representative, District Office or Service Center.

Replacement bulbs for standard application are:

ASCO number 343-978-3 green LED (Feature 9A)

ASCO number 343-978-1 red LED (Feature 9B)

Replacement bulb for oil-tight, watertight and weatherproof applications is ANSI #1819. (incandescent)

Do not substitute!

## TROUBLE-SHOOTING

Note any optional accessories that may be furnished on the switch and review their operation: Refer to pages 12 -15, and any separate drawings and/or publications that may be packed with the switch.

**WARNING:** Proceed with care! The automatic transfer switch is energized.

PROBLEM	CHECK IN NUMERICAL SEQUENCE			
	1 OPERATION	2 GEN-SET	3 VOLTAGE	4 CIRCUIT
Gen-Set does not start when <i>Transfer Test</i> switch is operated or when normal source fails.	Hold <i>Transfer Test</i> switch 15 seconds or the outage must be long enough to allow for Feature 1 time delay plus engine cranking and starting time.	Starting control must be in <i>automatic</i> position. Batteries must be charged and connected. Check wiring to engine starting contacts.	—	Ohmmeter should indicate an open circuit between control panel terminals CP19 and CP20 after Feature 1 time delay.
Transfer switch does not transfer the load to emergency after the gen-set starts.	Wait 2 minutes to allow for Feature 2B time delay.	Generator output circuit breaker should be closed. Generator frequency must be at least 95% of nominal (57 Hz for a 60 Hz system).	Voltmeter should read at least 90% of nominal phase to phase voltage between control panel terminals CP14 and CP15.	Voltmeter should read voltage between control panel terminals CP1 and CP6, and between CP2 and CP5. No voltage between CP1 and CP6 means a transfer switch problem or a loose in-line disconnect plug. No voltage between CP2 and CP5 means a control panel problem.
Transfer switch does not retransfer the load when normal returns or when the <i>Transfer Test</i> switch is released	Wait 30 minutes to allow for Feature 3A time delay.	—	Voltmeter should read at least 90% of nominal phase to phase voltage between control panel terminals CP28 and CP29, CP29 and CP30, and CP30 and CP28. (CP29 and CP30 only for 2 pole switches). There should be no voltage between CP26 and CP27.	Voltmeter should read voltage between control panel terminals CP3 and CP4, and between CP2 and CP5. No voltage between CP3 and CP4 means a transfer switch problem or a loose in-line disconnect plug. No voltage between CP2 and CP5 means a control panel problem.
Gen-Set does not stop after load retransfer to the normal source.	Wait 7 minutes to allow for Feature 2E time delay.	Starting control must be in <i>automatic</i> position.	—	Ohmmeter should indicate a closed circuit between control panel terminals CP19 and CP20 after Feature 2E time delay.

If the problem is isolated to the signal circuits on the control panel or the transfer switch, call your local ASCO Authorized Representative, District Office, or Service Center. Furnish the Serial No. and Catalog No. from the transfer switch nameplate.

## DISCONNECTING THE CONTROL PANEL

The in-line disconnect plug is furnished for repair purposes only and should not have to be separated. If it must be separated, follow these steps carefully.

### Disconnecting the Plug

**WARNING:** Do not unplug the control panel until step 1a. or 1b. below is followed.

1. Observe the position of the transfer switch.
  - a. If the transfer switch is in the *Normal* position, place the standby engine starting control in the *off* position. Then open the emergency source circuit breaker.
  - b. If the transfer switch is in the *Emergency* position, open the normal source circuit breaker. Place the engine starting control in the *test* or *run* position.
2. Separate the in-line disconnect plug by squeezing the latches. Do not pull on the wires.
3. Remove, label, and tape the signal wires connected to the engine start terminals on the transfer switch: TB 14 and TB 15, or TB 14 and TB 16.
4. Remove, label, and tape the wire connected to control panel terminal CP 2.

### Reconnecting the Plug

**WARNING:** Do not reconnect the control panel until steps 1a. or 1b. and 2 below are followed.

1. Observe the position of the transfer switch.
  - a. If the transfer switch is in the *Normal* position, be sure the standby engine starting control is still in the *off* position. The emergency source circuit breaker still should be open yet.
  - b. If the transfer switch is in the *Emergency* position, the normal source circuit breaker still should be open.
2. Reconnect the signal wires to the appropriate engine start terminals on the transfer switch. Reconnect the wire previously removed from control panel terminal CP 2.
3. Carefully align the disconnect plug halves then press them straight together until both latches click. Do not roll the plug together.
4. Restore the opposite source as follows:
  - a. If the transfer switch is in the *Normal* position, place the standby engine starting control in the *automatic* position. Then close the emergency source circuit breaker.
  - b. If the transfer switch is in the *Emergency* position, close the normal source circuit breaker. The load will be automatically retransferred to the normal source after Feature 3A time delay. For immediate retransfer, open and then reclose the emergency source circuit breaker. Place the engine starting control in the *automatic* position.

## MANUAL LOAD TRANSFER

This procedure will manually transfer the load if the control panel is disconnected:

**WARNING:** Do not manually operate the transfer switch until both power sources are disconnected.

1. Open the normal and emergency source circuit breakers.
2. Use the manual handle to manually operate the transfer switch to the opposite source. Remove the handle if detachable. See page 4.
3. If the transfer switch is in the *Emergency* position manually start the engine generator and then close the emergency source circuit breaker.



## SEQUENCE OF OPERATION

*See the Composite Elementary Wiring Diagram.*

*Note any Optional Accessories that may be furnished on this switch, and review their operation: Refer to pages 12-15, and any separate drawings and/or publications that may be packed with the switch.*

### Normal Source Failure

Load transfer to the emergency source automatically begins when the voltage sensor detects reduced voltage or total loss of the normal source. Relay SE will de-energize whenever the voltage level falls below the preset dropout point of the voltage sensor. An under voltage condition on any phase of the normal source is detected by the sensor.

SE relay de-energizes, signalling a failure, and relay NR begins its timing cycle (Feature 1). NR relay is provided with a time delay on dropout to override momentary outages. This delay prevents nuisance starting of the engine-driven generator. If the normal source voltage returns above the sensor dropout setting before the time delay expires, the SE relay energizes and the timing cycle is reset to zero.

NR relay de-energizes after the time delay and signals the engine-driven generator to start. At the same time, a voltage and frequency sensor begins monitoring the emergency source. The sensor will accept the emergency source only when both voltage and frequency reach preset pickup points. Usually about ten seconds elapse from dropout of the NR relay to acceptance by the sensor. This time span occurs because the engine-driven generator must crank, start, and run up to nominal pickup points. If the emergency source is available immediately, the sensor may accept it as soon as NR relay drops out.

When the emergency source is accepted by the sensor, relay ER begins its timing cycle (Feature 2B). ER relay is provided with a time delay on pickup to prevent immediate load transfer to the emergency source.

ER relay energizes, the TS coil is energized, the transfer switch operates, and all switch contacts (mains, controls, auxiliaries) reverse position. The transfer switch is now supplying the load from the emergency source.

The switch will remain in the *Emergency* position until the normal source is restored.

### Normal Source Restoration

Load retransfer to the normal source automatically begins when the voltage sensor detects restoration of the normal source. The voltage level must rise above the preset pickup point on all phases before the sensor will accept the normal source again.

When the normal source is accepted by the sensor, relay SE begins its timing cycle (Feature 3A). SE relay is provided with a time delay on pickup to prevent immediate load retransfer to the normal source. The delay insures that the normal source has stabilized before reconnection of vital loads. If the normal source voltage falls below the preset dropout point before the time delay expires, the timing cycle is reset to zero. If the emergency source fails during the timing cycle, ER relay drops out, and the load is immediately retransferred to the normal source, if that source is acceptable.

SE relay energizes and ER relay is dropped out. The TS coil is energized, the transfer switch operates, and all switch contacts (mains, controls, auxiliaries) reverse position. The transfer switch is now supplying the load from the normal source.

Upon retransfer to the normal source, NR relay begins its timing cycle (Feature 2E). NR relay is provided with a time delay on pickup to keep the engine running for a cool-down period.

NR relay energizes after the time delay and signals the engine-driven generator to shut down. All circuits are reset for any future normal source failure.

## SENSOR ADJUSTMENTS

The voltage and frequency sensor pickup and dropout points are factory set to the job specifications. The standard factory setting is used unless otherwise specified. If a setting must be changed, contact your local ASCO Authorized Representative, District Office, or Service Center.

**CAUTION:** Any indiscriminate change in these settings may affect the normal operation of the automatic transfer switch. This change could allow the load circuits to remain connected to a low voltage source.

FEATURE	SENSOR DESCRIPTION	SETTING	% of nominal	
			FACTORY SETTING	ADJUSTMENT RANGE
4A, 4B	Normal Source Voltage	Pickup	90%	85 to 100%
		Dropout	85%	75 to 98% of pickup setting

Emergency Source Voltage	Pickup	90%	85 to 100%
	Dropout	A fixed differential of approximately 15% below the pickup setting	

Emergency Source Frequency	Pickup	95%	90 to 100%
	Dropout	A fixed differential of approximately 12% below the pickup setting	

## TIME DELAY ADJUSTMENTS

Features 1, 2B, 3A, and 2E time delays are factory set to the job specifications. Unless otherwise specified, the standard factory setting is used. If these time delays must be changed, carefully follow the procedure on page 11; a knife and small screwdriver are needed.

Use the table below as a guide to approximate time delays and their corresponding potentiometer settings. The potentiometers are shown with A1 board vertical.

**CAUTION:** Do not unplug the A1 board while the control panel is energized.

### APPROXIMATE POTENTIOMETER SETTINGS

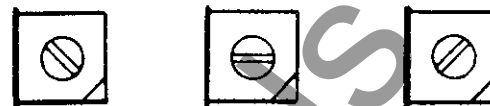

FEATURE	TIME DELAY DESCRIPTION	FACTORY SETTING	ADJUSTMENT RANGE	MAX. CCW	½ CW	MAX. CW
1	override momentary outages	1 second	½ to 6 seconds	½ second	3 seconds	6 seconds
2B	transfer to emergency	0 minutes	0 to 1 minute	0 minute	½ minute	1 minute
*3A	retransfer to normal	30 minutes	½ to 30 minutes	½ minute	15 minutes	30 minutes
2E	gen-set cool down	5 minutes	0 to 5 minutes	0 minutes	2½ minutes	5 minutes

\*If the slide switch is in the *Min.* position (down), Feature 3A is not used.

CCW = Counterclockwise  
CW = Clockwise

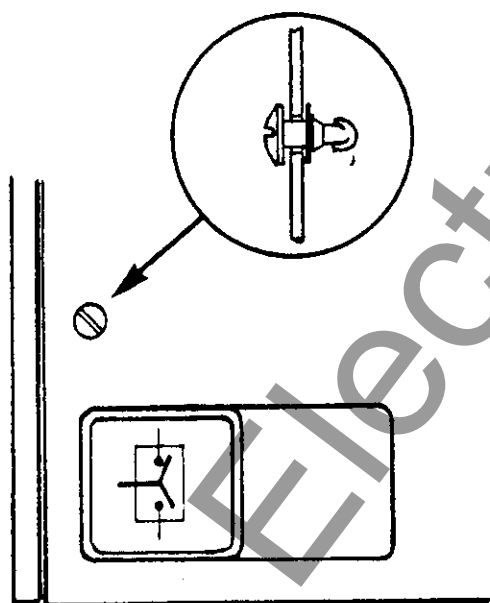

Figure 8. ¼ turn control panel cover fasteners

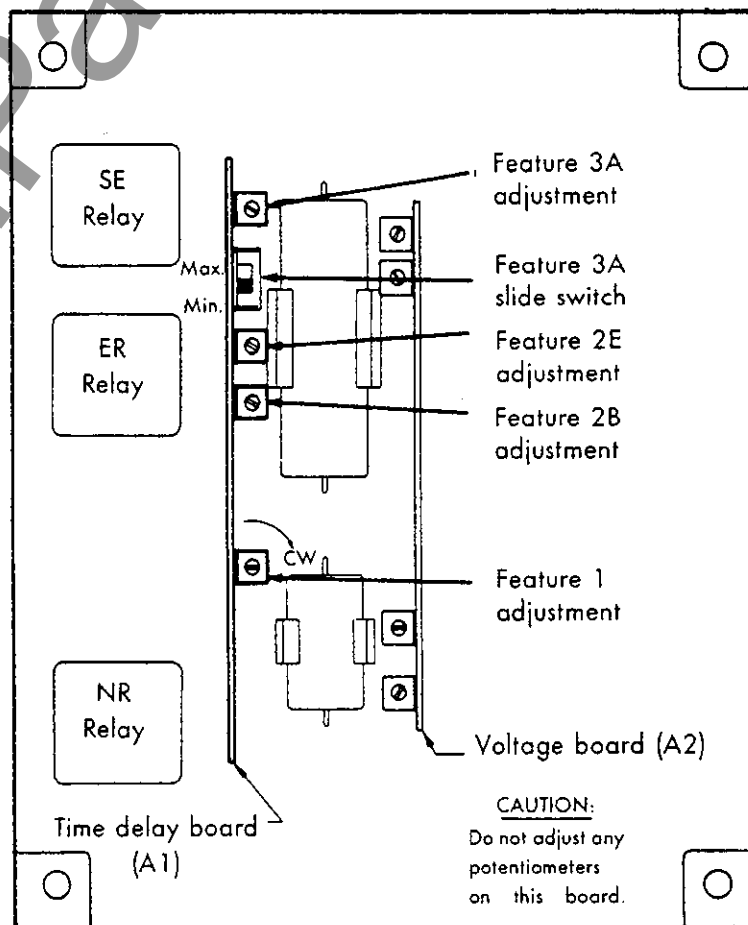

Figure 9. Location of potentiometers

# TIME DELAY ADJUSTMENTS

(continued)

## How to Change a Time Delay

1. Prevent the transfer switch from operating by disconnecting one source as follows:
  - a. If the transfer switch is in the *Normal* position, open the emergency source circuit breaker. Turn the engine starting control to *off*.
  - b. If the transfer switch is in the *Emergency* position, open the normal source circuit breaker. Turn the engine starting control to *test* or *run*.
2. Separate the in-line disconnect plug by squeezing the latches. Do not pull on the wires.
3. Remove the cover from the control panel. Use a screwdriver to turn the fasteners  $\frac{1}{4}$  turn. See Figure 8.
4. Remove the *A1* time delay board from its socket by pressing both latches outward. See Figures 9 and 10.
5. Use a knife to scrape the seal off the potentiometer to be adjusted. Support the potentiometer with your fingers. See Figure 11.

Use a small screwdriver to turn the potentiometer clockwise to increase the time delay or counter clockwise to decrease it.
6. Reinstall the *A1* time delay board into its socket. Align the board slot with the socket insert and press the board in until both latches click. See Figure 12.
7. Install the cover on the control panel. Align the cover over the two standing brackets, push it inward, and turn the fasteners  $\frac{1}{4}$  turn. See Figure 8.
8. Reconnect the in-line disconnect plug. The latches should click.
9. Restore the disconnected source as follows:
  - a. If the transfer switch is in the *Normal* position close the emergency source circuit breaker.
  - b. If the transfer switch is in the *Emergency* position, close the normal source circuit breaker. The load will be automatically retransferred to the normal source after Feature 3A time delay. For immediate retransfer, open and then reclose the emergency source circuit breaker.
10. Turn the engine starting control to *automatic*.

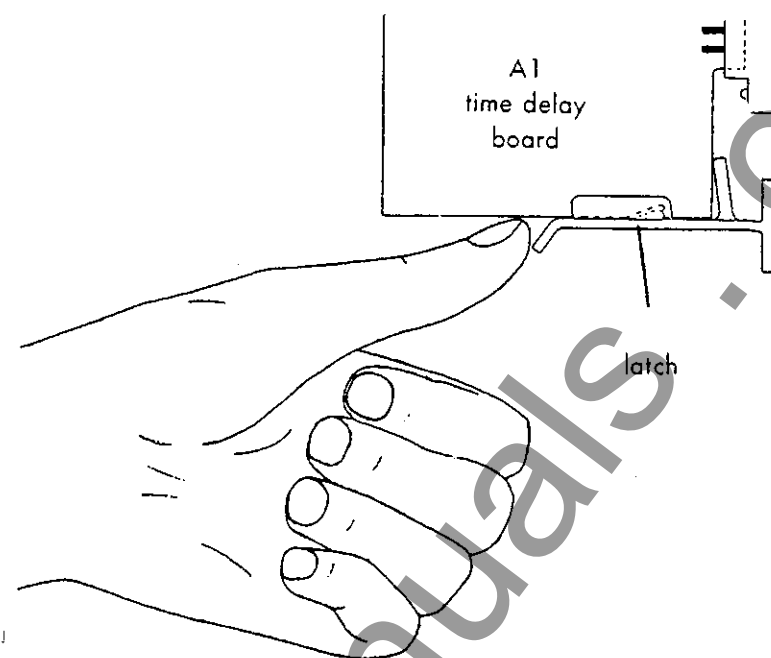

Figure 10. Time delay board latch

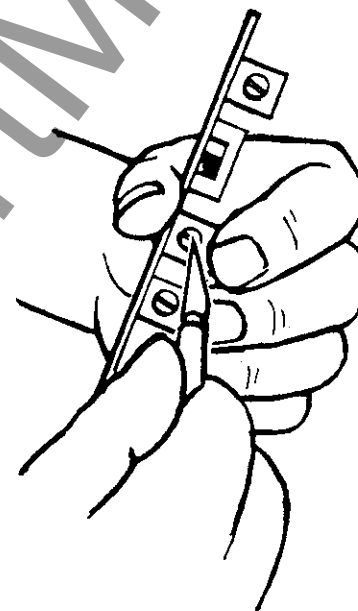

Figure 11. Potentiometer seal removal

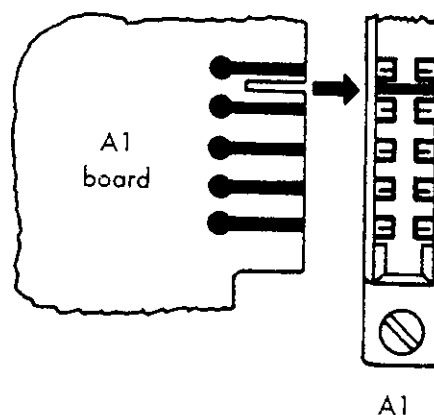

Figure 12. Socket insert

## OPTIONAL MANUAL CONTROLS

These manual controls, if furnished, are connected and mounted on the enclosure door, or are shipped loose for open-type automatic transfer switches.

- ✓  
 **Acc. 6A** Reset switch to manually retransfer the automatic transfer switch to the normal source. See Figure 13.

### Sequence of Operation

*Normal Source Restoration:* When the normal source is accepted by the sensor, SE relay remains de-energized until the reset switch is momentarily closed. The standard Sequence of Operation is resumed after SE relay is energized.

- ✓  
 **Acc. 6B** Reset switch to manually bypass time delay on retransfer to the normal source. See Figure 14.

### Sequence of Operation

*Normal Source Restoration:* When the normal source is accepted by the sensor, SE relay begins its timing cycle. This timing cycle is nullified and SE relay energizes when the reset switch is momentarily closed. The standard Sequence of Operation is resumed after SE relay is energized.

- ✓  
 **Acc. 6C** Reset switch to manually retransfer the automatic transfer switch to the normal source with automatic retransfer in event of emergency source failure. If **Feature 3A** is used, wait until the time delay has expired before operating the reset switch. See Figure 15.

### Sequence of Operation

*Normal Source Restoration:* When the sensor accepts the normal source, SE relay remains de-energized until the reset switch is momentarily closed. If the emergency source fails before the reset switch is depressed, the load is immediately retransferred to the normal source. The standard Sequence of Operation resumes after SE relay energizes.

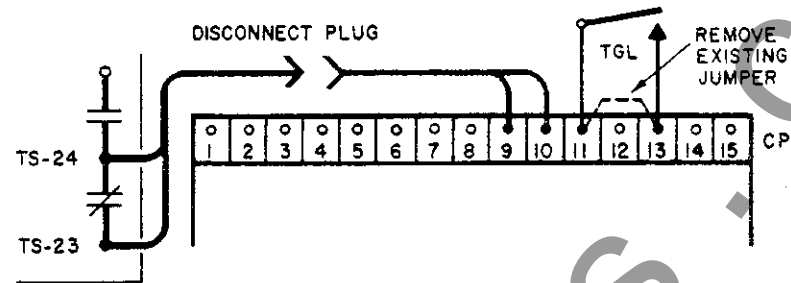

Figure 13. Optional Accessory 6A

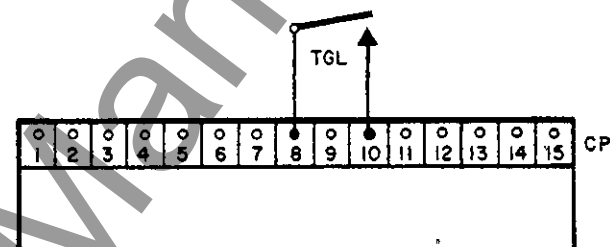

Figure 14. Optional Accessory 6B

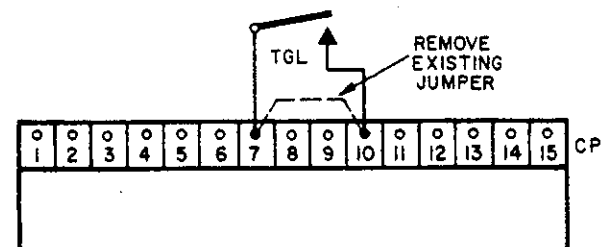

Figure 15. Optional Accessory 6C

## OPTIONAL REMOTE CONTROL

- ✓  
 **Acc. 17** Terminal provisions for Area Protection remote contact which opens to signal automatic transfer switch to transfer to the emergency source.

Connect a normally closed contact (gold plated low voltage) to control panel terminals CP11 and CP13. See Figure 16.

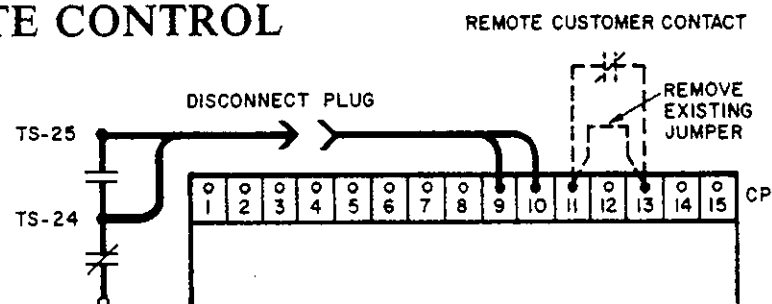

Figure 16. Optional Accessory 17

## OPTIONAL ACCESSORY 11 ENGINE-GENERATOR EXERCISING TIMER

This timer, if furnished, is connected and mounted below the control panel. The timer is used for periodic exercising of the emergency engine-generator plant. The timer is factory set for a 20 minute minimum exercise period once a week. The time period can be lengthened and can be set to occur more often than once a week. The engine-generator should be exercised under load once a week for a minimum time period of 20 minutes, or follow the recommendations of the engine-generator set manufacturer. See Figure 17.

- ✓
- Acc. 11A** Timer exercises the engine generator without load for the set time period. The automatic transfer switch is not affected.
- ✓
- Acc. 11B** Timer simulates a normal source failure. The automatic transfer switch transfers the electrical load to the emergency generator during the exercise period.

### How to Set the Timer

First check the manual trip and reset levers located on either side of the timer's nameplate. The right manual trip lever should be up, and the left reset lever should be down.

**Exercise Day.** Choose what day(s) you want to exercise the engine-generator set. Remove the screw(s) from the star wheel lobe(s) marked with the day(s) you have chosen.

**Exercise Period.** Decide what time you want to start the exercise period. Position the light color tripper on the dial edge at the start time. Tighten the knurled screw. Likewise, decide what time you want to stop the exercise period. Position the dark color tripper on the dial edge at the stop time. Tighten the knurled screw.

**CAUTION:** Do not turn the dial clockwise or you may damage the timer. Turn it counterclockwise (direction of arrow on the timer).

**Present Time and Day.** Find the present time on the dial. Turn the dial counterclockwise (direction of arrow) until the present time is adjacent the *time* arrow (lower right). Find the star wheel lobe marked with today's day of the week. Turn the star clockwise until today's lobe touches the red lever.

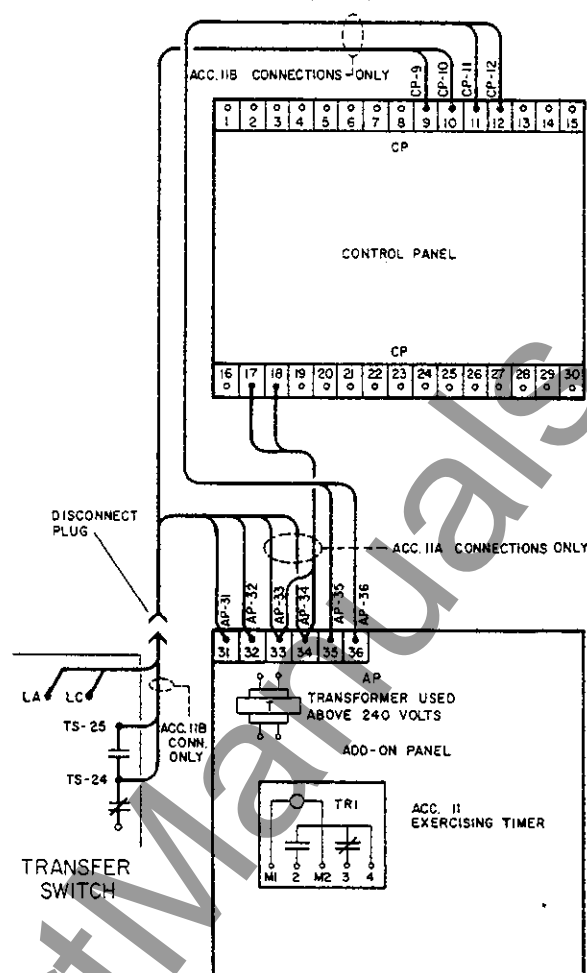

Figure 17. Optional Accessories 11A and 11B

### Trouble-Shooting

If Acc. 11A timer contact 4-2 does not close during the set exercise period, the engine generator plant will not be signalled to run. If the contact remains closed beyond the set exercise period, the plant will continue running. In either case, Acc. 11A timer is malfunctioning. Check the dial for loose trippers.

If Acc. 11B timer contact 4-3 does not open during the set exercise period, the engine generator plant will not be signalled to run and the load will not be transferred to the emergency source. If the contact remains open beyond the set exercise period, the plant will continue running and the load will remain connected to the emergency source. Immediate retransfer may be accomplished by manually shutting down the engine. Make sure that full rated normal voltage is available before doing this. In either case, Acc. 11B timer is malfunctioning. Check for loose trippers on the dial. If necessary, Acc. 11B can be bypassed by adding a jumper wire between terminals AP35 and AP36. Do not disconnect any wires.

# STANDARD AND OPTIONAL ACCESSORY 14 INDICATORS

One Feature 14A and one Feature 14B auxiliary contacts are provided standard on all automatic transfer switches. Their terminals are:

Feature 14A	TS 12 and TS 13
Feature 14B	TS 10 and TS 11

**WARNING:** do not make any connections before de-energizing both the normal and emergency sources: Open both circuit breakers.

Optional Accessory 14's, if furnished, are mounted on the transfer switch. Connect external circuits to the terminals indicated. The location of the auxiliary contacts varies according to the amp size of the transfer switch. See Figures 18 through 22.

✓  
 **Acc. 14A** Auxiliary contact closed when automatic transfer switch is connected to the normal source.  
 Terminals are as follows:

first optional	TS 31 and TS 32
second optional	TS 35 and TS 36
third optional	TS 39 and TS 40

✓  
 **Acc. 14B** Auxiliary contact closed when automatic transfer switch is connected to the emergency source.  
 Terminals are as follows:

first optional	TS 29 and TS 30
second optional	TS 33 and TS 34
third optional	TS 37 and TS 38

Auxiliary Contact Rating: 10 amps 480 VAC

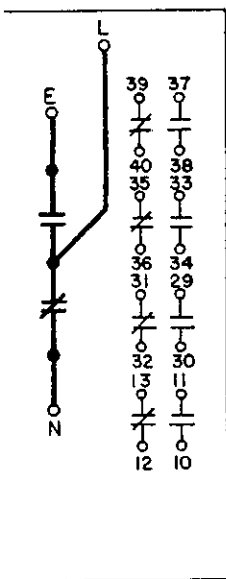

Figure 18.  
30-150 amps.

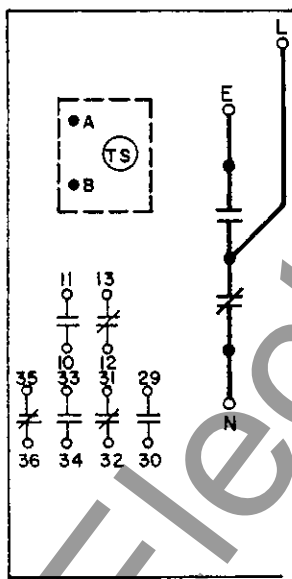

Figure 19.  
260-400 amps.

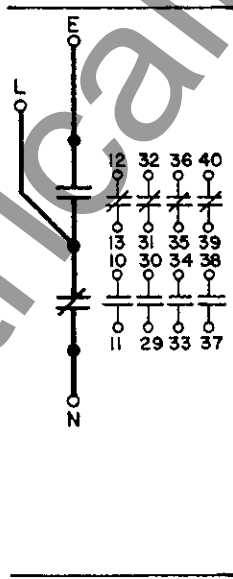

Figure 20.  
600-800 amps.

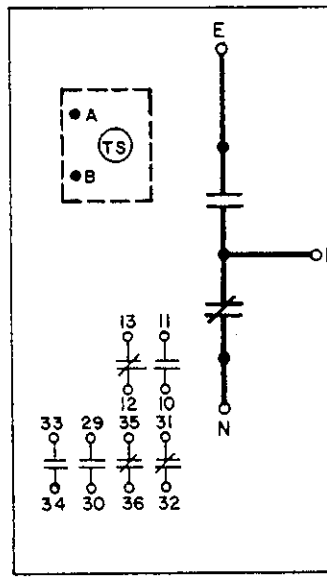

Figure 21.  
1000-1200 amps.

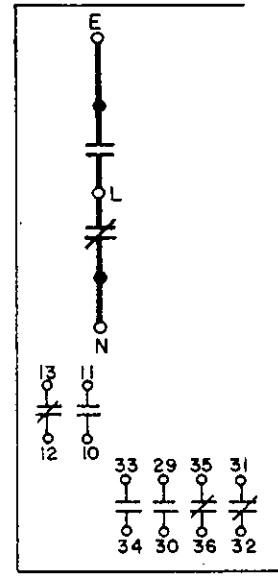

Figure 22.  
1600-4000 amps.

## OPTIONAL ACCESSORY 27 MOTOR LOAD TRANSFER

✓  
 **Acc. 27**, if furnished, is an inphase monitor control for transfer and retransfer of motor loads, so that inrush currents do not exceed normal starting currents. This avoids nuisance tripping of circuit breakers and possible mechanical damage to motor couplings. See Figure 23.

### Sequence of Operation

*Normal Source Restoration:* SE relay energizes and ER relay is dropped out. After approximately 2 seconds the inphase monitor senses both sources of power, and its output relay energizes to initiate inphase transfer. The TS coil is energized and the standard Sequence of Operation is resumed.

When *Transfer Test* switch is used, the inphase monitor senses both sources of power approximately 2 seconds after the ER relay energizes. The TS coil is energized and the standard Sequence of Operation is resumed.

If either source of power is not available when the inphase monitor starts its sensing mode, the output relay picks up after 2 seconds and allows the TS coil to be energized.

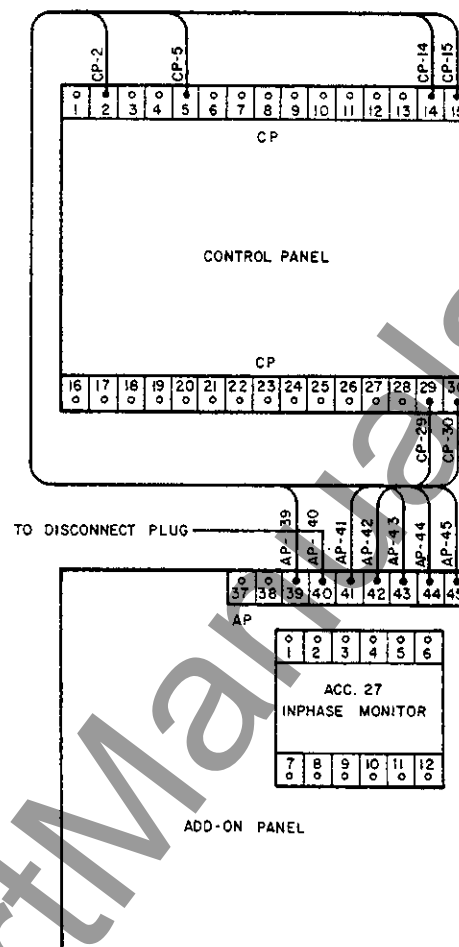

Figure 23. Optional Accessory 27

### Trouble-Shooting

1. Connect a voltmeter between terminals NA and EA on the transfer switch. Set the meter scale to at least twice the system phase to phase voltage.
2. Manually start the engine generator plant. After it has reached maximum output voltage, the meter needle should sweep back and forth at a regular rate between 0 volts and about twice the system voltage.
3. Depress and hold the *Transfer Test* switch. The load should transfer to the emergency source when the meter needle is near 0 volts. If transfer does not occur, Acc. 27 is malfunctioning.
4. Release the *Transfer Test* switch. The load should retransfer back to the normal source after Feature 3A time delay, if used. The retransfer should occur when the needle is near 0 volts. If retransfer does not occur after the time delay, Acc. 27 is malfunctioning.
5. Immediate retransfer may be accomplished by manually shutting down the engine. Make sure that full rated normal voltage is available before doing this.
6. Disconnect and remove the voltmeter.

If necessary, Acc. 27 can be bypassed by adding a jumper wire between terminals AP 39 and AP 40. Do not disconnect any wires from those terminals.



**NOTES**

[www.ElectricalPartManuals.com](http://www.ElectricalPartManuals.com)

# Important Warranty Notice

COMPLETE AND MAIL CARD ATTACHED.  
FOR 1 YEAR WARRANTY FROM DATE OF INSTALLATION  
PLEASE REGISTER YOUR ASCO EQUIPMENT.

When you complete and mail the attached postage free card,  
you *extend your product warranty* to apply from date of  
installation.

If card is not returned, product can only be warranted from  
date of shipment from factory.

Warranty (reverse side) should be retained by owner.

detach along perforated line

for your records

SERIAL NO. ....

CATALOG NO. ....

**DATE OF INSTALLATION:**  
\_\_\_\_\_

**INSTALLED BY:**

\_\_\_\_\_  
Company

\_\_\_\_\_  
Address

PLEASE REGISTER THE FOLLOWING INSTALLATION

SERIAL NO. ....

CATALOG NO. ....

**DATE OF INSTALLATION:**  
\_\_\_\_\_

**INSTALLED BY:**

\_\_\_\_\_  
Company

\_\_\_\_\_  
Address

**LOCATION:**

\_\_\_\_\_  
Company

\_\_\_\_\_  
Address

**PERSON COMPLETING FORM:**  
\_\_\_\_\_

Automatic Switch Co. Florham Park, N. J.

## Your Warranty

The Seller warrants its products and equipment to be free from defects in material or workmanship over a period of one year from date of shipment from its factory.

Equipment will be replaced or put in proper operating condition, free of all charges except transportation, and the correction of any defects by repair or replacement by the Seller shall constitute fulfillment of all obligations and liability of the Seller to the Buyer under this Warranty. The limit of Seller's liability with respect to any product(s) furnished hereunder, whether in contract, in tort, under any warranty, or otherwise, shall be the contract price herein of the specific product on which such liability is based.

When equipment is returned for repair due to causes not covered by Seller's warranty, the Buyer shall notify the Seller in writing and, after receipt of shipping advice, the Buyer may return it to the Automatic Switch Company, Receiving Department, Hanover Road, Florham Park, N.J. 07932, carrying charges prepaid. Seller's Service Department will put such equipment in operating condition at the lowest possible cost. When necessary to make a return, give all possible information regarding the trouble experienced and complete details of the installation with which the

device was used.

The Seller is not responsible for damage of its products through improper installation, maintenance, use, repairs or adjustments, or attempts to operate it above its rated capacity or voltage, intentionally or otherwise, or for unauthorized repairs.

Seller shall not be liable for and Buyer assumes responsibility for all personal injury and property damage resulting from the handling, possession or use of the goods by Buyer.

Seller shall not be liable for specific or consequential damages in any claim, action, suit or proceeding arising under this transaction, nor shall there be any liability thereunder for claims for labor, loss of profits or good will, repairs or other expenses incidental to replacement.

No other representations, guarantees or warranties, express or implied, are made by the Seller and the foregoing warranty is in lieu of all other representations and warranties, express or implied, which are hereby expressly disclaimed and waived by Buyer, including any warranty of merchantability or of fitness for particular purpose.

**Automatic Switch Co.**  
FLORHAM PARK, NEW JERSEY U.S.A. 07932

ASCO

detach along perforated line

NO POSTAGE  
NECESSARY  
IF MAILED  
IN THE  
UNITED STATES



**BUSINESS  
REPLY MAIL**

FIRST CLASS PERMIT NO. 2 FLORHAM PARK, N.J.

Postage will be paid by

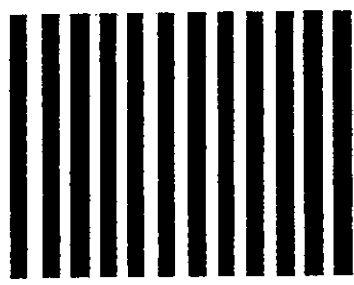

**AUTOMATIC SWITCH CO.**  
50 - 56 Hanover Road  
Florham Park, N.J. 07932

Attn: Switch Service Manager



Note: Extend your  
Warranty to apply  
from date of install-  
ation by complet-  
ing and returning  
the attached post  
card.

SERVICE RECORD

[www.ElectricalPartManuals.com](http://www.ElectricalPartManuals.com)

# THREE PHASE AUTOMATIC

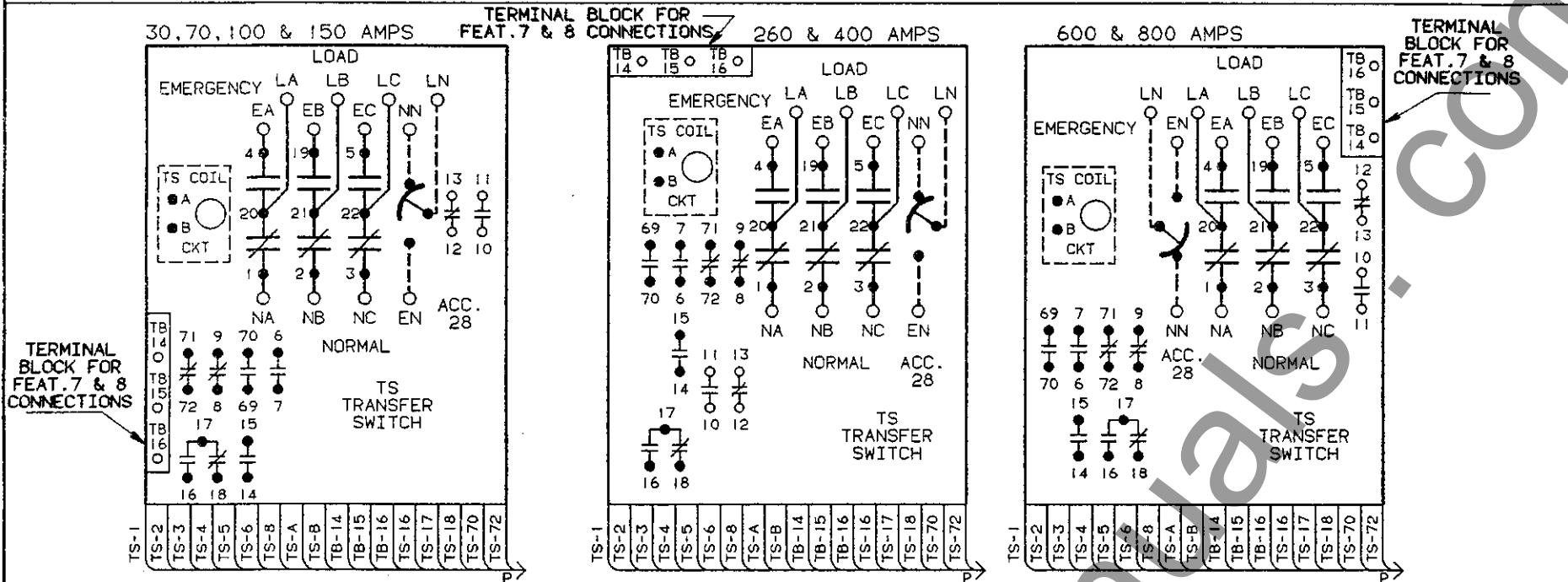

## STANDARD FEATURES

- VOLTAGE AND FREQUENCY SENSING**
- CLOSE DIFFERENTIAL VOLTAGE SENSING ON ALL PHASES OF NORMAL SOURCE. PICKUP VOLTAGE IS ADJUSTABLE FROM 85% TO 100% OF NOMINAL AND THE DROPOUT IS ADJUSTABLE FROM 75% TO 98% OF THE PICKUP VALUE. FACTORY SET TO PICKUP AT 90% AND DROPOUT AT 85% OF NOMINAL UNLESS OTHERWISE SPECIFIED. STANDARD FEATURE 4B.
  - SINGLE PHASE VOLTAGE SENSING OF EMERGENCY SOURCE. PICKUP ADJUSTABLE FROM 85% TO 100% OF NOMINAL. FACTORY SET TO PICKUP AT 90% UNLESS OTHERWISE SPECIFIED.
  - FREQUENCY SENSING OF EMERGENCY SOURCE. PICKUP ADJUSTABLE FROM 90% TO 100% OF NOMINAL. FACTORY SET TO PICKUP AT 95% UNLESS OTHERWISE SPECIFIED.

### TIME DELAYS

- TIME DELAY TO OVERRIDE MOMENTARY NORMAL SOURCE OUTAGES TO DELAY ALL TRANSFER SWITCH AND ENGINE STARTING SIGNALS. ADJUSTABLE FROM 0.5 TO 6 SECONDS. FACTORY SET AT 1 SECOND UNLESS OTHERWISE SPECIFIED. STANDARD FEATURE 1.
- RETRANSFER TO NORMAL TIME DELAY. TIME DELAY IS AUTOMATICALLY BYPASSED IF EMERGENCY SOURCE FAILS AND NORMAL SOURCE IS AVAILABLE. ADJUSTABLE FROM 0.5 TO 30 MINUTES. FACTORY SET AT 30 MINUTES UNLESS OTHERWISE SPECIFIED. STANDARD FEATURE 3A.
- UNLOADED RUNNING TIME DELAY FOR EMERGENCY ENGINE GENERATOR COOLDOWN. ADJUSTABLE FROM 0 TO 5 MINUTES. FACTORY SET AT 5 MINUTES UNLESS OTHERWISE SPECIFIED. STANDARD FEATURE 2E.

- TRANSFER TO EMERGENCY TIME DELAY. ADJUSTABLE FROM 0 TO 1 MINUTE. FACTORY SET AT 0 MINUTES UNLESS OTHERWISE SPECIFIED. STANDARD FEATURE 2B.

### ENGINE CONTROL CONTACTS

- A CONTACT THAT CLOSURES WHEN NORMAL SOURCE FAILS. GOLD PLATED CONTACTS FOR LOW VOLTAGE ENGINE START SIGNALS OR OTHER CUSTOMER USE. RATED 10 AMPS, 32 VOLTS DC. STANDARD FEATURE 7.
- A CONTACT THAT OPENS WHEN NORMAL SOURCE FAILS. GOLD PLATED CONTACTS FOR LOW VOLTAGE ENGINE START SIGNALS OR OTHER CUSTOMER USE. RATED 10 AMPS, 32 VOLTS DC. STANDARD FEATURE 8.

### MANUAL CONTROLS

- TEST SWITCH TGL WITH GOLD PLATED LOW VOLTAGE CONTACTS TO MOMENTARILY SIMULATE NORMAL SOURCE FAILURE. INSTALLED AND CONNECTED ON DOOR OF ENCLOSED TYPE. SHIPPED LOOSE FOR OPEN TYPE. STANDARD FEATURE 5.

### INDICATORS

- ONE AUXILIARY CONTACT CLOSED WHEN AUTOMATIC TRANSFER SWITCH IS CONNECTED TO NORMAL. NOTE: ADDITIONAL AUXILIARY CONTACTS ARE AVAILABLE AS OPTIONS. STANDARD FEATURE 14A.
- ONE AUXILIARY CONTACT CLOSED WHEN AUTOMATIC TRANSFER SWITCH IS CONNECTED TO EMERGENCY. NOTE: ADDITIONAL AUXILIARY CONTACTS ARE AVAILABLE AS OPTIONS. STANDARD FEATURE 14B.
- SIGNAL LIGHT PLI, INDICATES WHEN AUTOMATIC TRANSFER SWITCH IS CONNECTED TO NORMAL SOURCE. INSTALLED AND CONNECTED ON DOOR OF ENCLOSED TYPE. SHIPPED LOOSE FOR OPEN TYPE. STANDARD FEATURE 9A. REFER TO OPERATOR'S MANUAL FOR REPLACEMENT NUMBER. (GREEN)

## OPTIONAL ACCESSORIES

### MANUAL CONTROLS FOR AUTOMATIC TRANSFER SWITCH

- 6A:** RESET SWITCH TO MANUALLY RETRANSFER THE AUTOMATIC TRANSFER SWITCH TO THE NORMAL SOURCE. GOLD PLATED LOW VOLTAGE CONTACTS. INSTALLED AND CONNECTED ON DOOR OF ENCLOSED TYPE. SHIPPED LOOSE OPEN TYPE.
- 6B:** RESET SWITCH TO MANUALLY BYPASS TIME DELAY ON RETRANSFER TO NORMAL. GOLD PLATED LOW VOLTAGE CONTACTS. INSTALLED AND CONNECTED ON DOOR OF ENCLOSED TYPE. SHIPPED LOOSE FOR OPEN TYPE.
- 6C:** RESET SWITCH TO MANUALLY RETRANSFER THE AUTOMATIC TRANSFER SWITCH TO THE NORMAL SOURCE AFTER TIME DELAY EXPIRES WITH AUTOMATIC RETRANSFER IN THE EVENT OF EMERGENCY SOURCE FAILURE. GOLD PLATED LOW VOLTAGE CONTACTS. INSTALLED AND CONNECTED ON DOOR OF ENCLOSED TYPE. SHIPPED LOOSE FOR OPEN TYPE.

### INDICATORS

- 14A:** AUXILIARY CONTACT CLOSED WHEN AUTOMATIC TRANSFER SWITCH IS CONNECTED TO NORMAL SOURCE. ONE AUXILIARY IS SUPPLIED AS STANDARD. SPECIFY TOTAL QUANTITY WHEN MORE THAN ONE IS REQUIRED.

- 14B:** AUXILIARY CONTACT CLOSED WHEN AUTOMATIC TRANSFER SWITCH IS CONNECTED TO EMERGENCY SOURCE. ONE AUXILIARY IS SUPPLIED AS STANDARD. SPECIFY TOTAL QUANTITY WHEN MORE THAN ONE IS REQUIRED.

### PLANT EXERCISERS

- 11A:** ENGINE GENERATOR EXERCISING TIMER WITHOUT LOAD. ADJUSTABLE IN 15 MINUTE INCREMENTS. FACTORY SET FOR 20 MINUTES MINIMUM EACH WEEK UNLESS OTHERWISE SPECIFIED. ADDITIONAL ACC. MTG. PANEL IS REQUIRED.
- 11B:** ENGINE GENERATOR EXERCISING TIMER WITH LOAD. ADJUSTABLE IN 15 MINUTE INCREMENTS. FACTORY SET FOR 20 MINUTES MINIMUM EACH WEEK UNLESS OTHERWISE SPECIFIED. ADDITIONAL ACC. M PANEL IS REQUIRED.

### REMOTE AUTOMATIC TRANSFER SWITCH CIRCUITS

- 17:** TERMINAL PROVISIONS FOR REMOTE CONTACT WHICH OPENS TO SIGNAL AUTOMATIC TRANSFER SWITCH TO TRANSFER TO EMERGENCY. SEE "AREA PROTECTION" IN ORDERING SECTION 8 OF ASCO CONTROLS CATALOG.

# TRANSFER SWITCHES

TERMINAL BLOCK FOR FEAT. 7 & 8 CONNECTIONS 1000 & 1200 AMPS

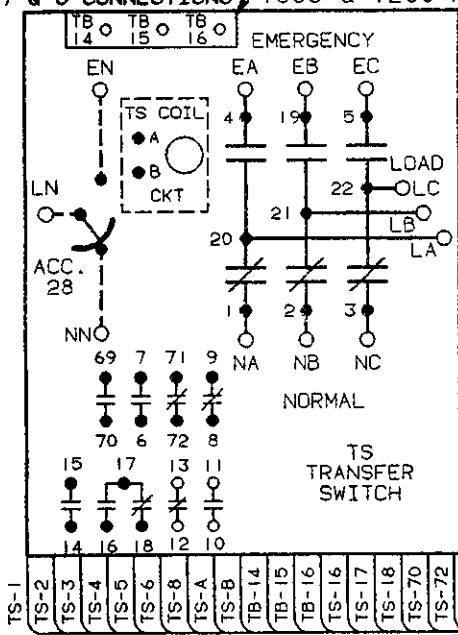

1600, 2000, 3000 & 4000 AMPS

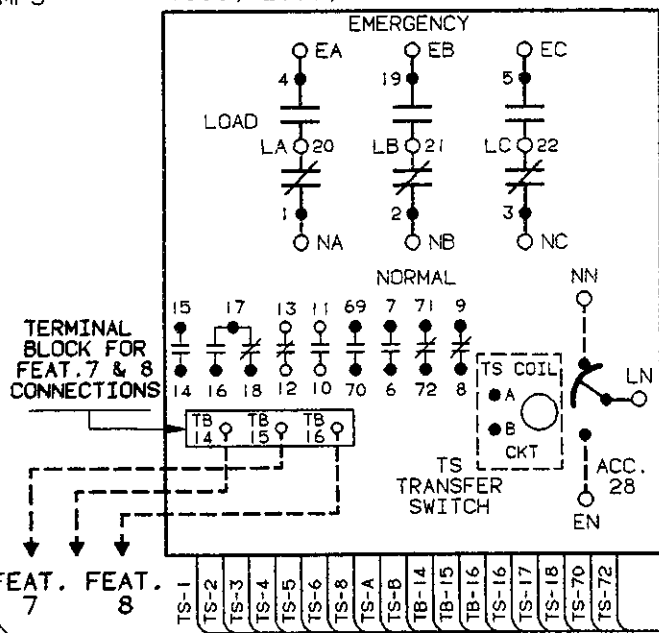

IN-LINE DISCONNECT PLUG FOR INTERCONNECTING HARNESS.

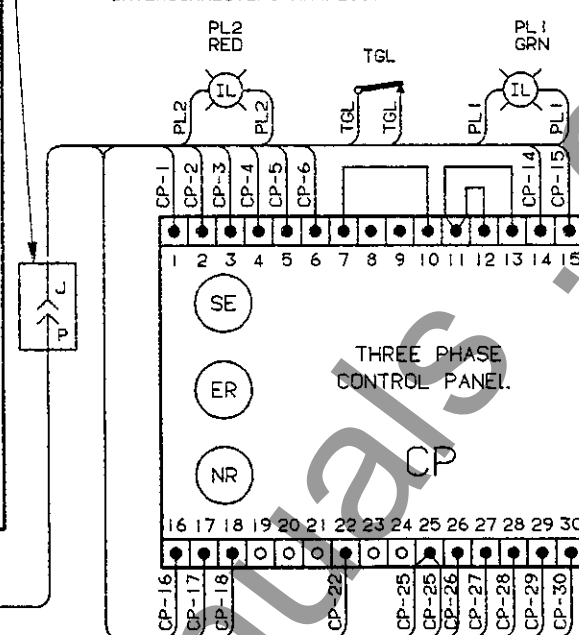

ADS SHOWN DOTTED ARE NOT CONNECTED(TYP).

## ELEMENTARY WIRING DIAGRAM

SIGNAL LIGHT PL2, INDICATES WHEN AUTOMATIC TRANSFER SWITCH IS CONNECTED TO EMERGENCY SOURCE. INSTALLED AND CONNECTED ON DOOR OF ENCLOSED TYPES. SHIPPED LOOSE FOR OPEN TYPES. STANDARD FEATURE 9B. REFER TO OPERATOR'S MANUAL FOR REPLACEMENT NUMBER. (RED)

### GENERAL NOTES

SWITCH SHOWN DE-ENERGIZED CONNECTED TO NORMAL SOURCE.  
 DEVICE SYMBOLS AND DESIGNATIONS ARE IN ACCORDANCE WITH NEMA PUB. ICS-1970. PART 1-101.

ALL WIRES: #20 AWG ON 30-150 AMPS AND # 16 AWG ON 260-4000 AMPS, STRANDED COPPER AND FOLLOW NEMA STANDARD ICS-1-112-64 COLOR CODE UNLESS OTHERWISE SPECIFIED.

○ INDICATES CUSTOMER CONNECTION POINTS.  
 ● INDICATES FACTORY CONNECTION POINTS.

CONNECTION POINTS THAT HAVE BOTH CUSTOMER CONNECTIONS AND FACTORY CONNECTIONS ARE SHOWN OPEN AS CUSTOMER CONNECTION POINTS.

ON ENCLOSED TYPES SWITCHES, THE TRANSFER UNIT IS MOUNTED ON THE BACK INSIDE SURFACE AND THE CONTROL PANEL ON THE INSIDE DOOR SURFACE. WHEN AN ADDITIONAL ACCESSORY MOUNTING PANEL IS REQUIRED TO MOUNT THE OPTIONAL ACCESSORIES, IT IS LOCATED DIRECTLY BELOW THE CONTROL PANEL.

OPERATOR'S MANUAL 1D4800 IS FURNISHED WITH EACH AUTOMATIC TRANSFER SWITCH. REFER TO THIS PUBLICATION PRIOR TO INSTALLATION AND OPERATION OF THE SWITCH.

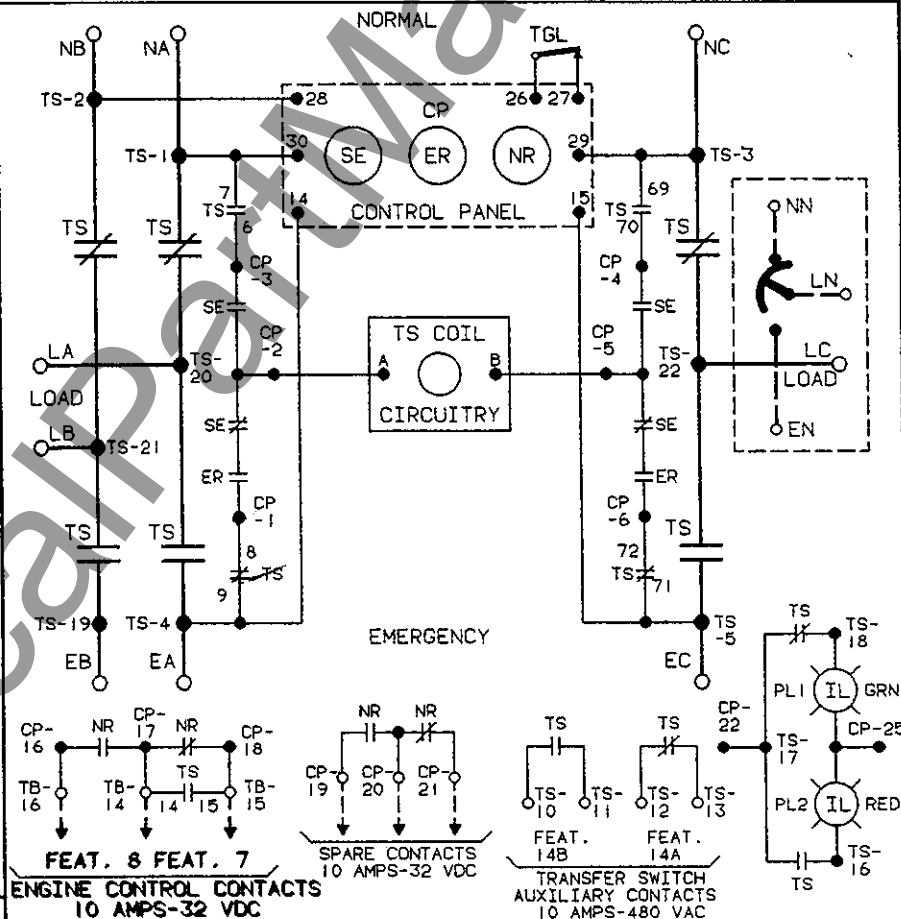

### MOTOR LOAD TRANSFER

27: INPHASE MONITOR CONTROLS FOR TRANSFER AND RETRANSFER OF MOTOR LOADS, SO THAT INRUSH CURRENTS DO NOT EXCEED NORMAL STARTING CURRENTS, TO AVOID NUISANCE TRIPPING OF CIRCUIT BREAKERS AND POSSIBLE MECHANICAL DAMAGE TO MOTOR COUPLINGS. SEE TRANSFERRING MOTOR LOADS IN TECHNICAL SECTION I OF ASCO CONTROLS CATALOG. ADDITIONAL ACC. MTG. PANEL IS REQUIRED.

### TRANSFER SWITCH OPTIONS

22: SOLID NEUTRAL, WITH FULL RATED TERMINALS. AL-CU, UL LISTED. SHIPPED LOOSE FOR OPEN TYPE.  
 28: OVERLAPPING NEUTRAL TRANSFER CONTACTS. ASSURES PROPER GROUND FAULT SENSING AND AVOIDS POSSIBLE PHASE OVERVOLTAGES DURING TRANSFER OF NEUTRAL BETWEEN NORMAL AND EMERGENCY. NOTE NORMAL AND EMERGENCY CONTACTS, ON ACC. 28 POLE ARE REVERSED ON 30-400 AMP AND 1600-4000 AMP SWITCHES. SEE "GROUND FAULT PROTECTION AND ASCO OPTIONAL ACC. 28" IN ORDERING SECTION I OF ASCO CONTROLS CATALOG.

SEE ATTACHED SHEET FOR ADDITIONAL ACCESSORIES.

COMPUTER GENERATED DRAWING					
BASIC CATALOG NUMBERS	VOLT. CODE	STD. ACC. CODE	OPT. ACC. CODE	ENCLOSURE CODE	VOLTAGE CODE DESCRIPTION OPERATING FREQ. 50-60 HZ
940	30	4	9	X	4 208Y/120V, 190 TO 208V
	70				6 240/120V TAPPED DELTA
	100				9 480Y/277V, 460Y/265V
	150				6 440 TO 480V
	260				9 600Y/347V
	400				G 550 TO 600V
	600				X OTHER VOLTAGES
	800				CATALOG NUMBER CERTIFIED
	1000				TO ASCO S.O.
	1200				DATE _____ BY _____
	1600				
	2000				
3000					
4000					

### COMPOSITE 3 PHASE ELEMENTARY WIRING DIAGRAM FOR ASCO 940 AUTOMATIC TRANSFER SWITCHES WITH GROUP 9 CONTROLS

BY	DATE	Automatic Switch Co.
DRAWN	TEK 3/83	FLORHAM PARK, N.J., 07932, PRINTED IN U.S.A.
CHECKED	NS 3/83	AL <input checked="" type="checkbox"/> AP <input checked="" type="checkbox"/>
DFTG APL	FM 3/83	PROPERTY OF AUTOMATIC SWITCH CO. USE PERMITTED FOR OUR WORK ONLY. ALL RIGHTS OF DESIGN OR INVENTION ARE RESERVED.
ENG APL	PDG 3/83	

85400	SEE ER	F	6/84	PDG
83934	SEE ER	E	4/84	PDG
80283	SEE ER	D	5/83	PDG
78907	REDRAWN	C	3/83	PDG
E.R. NO.	ITEM CHNG.	CHG.	DATE	APVD.
		F		

JS345-541

# SINGLE PHASE AUTOMATIC

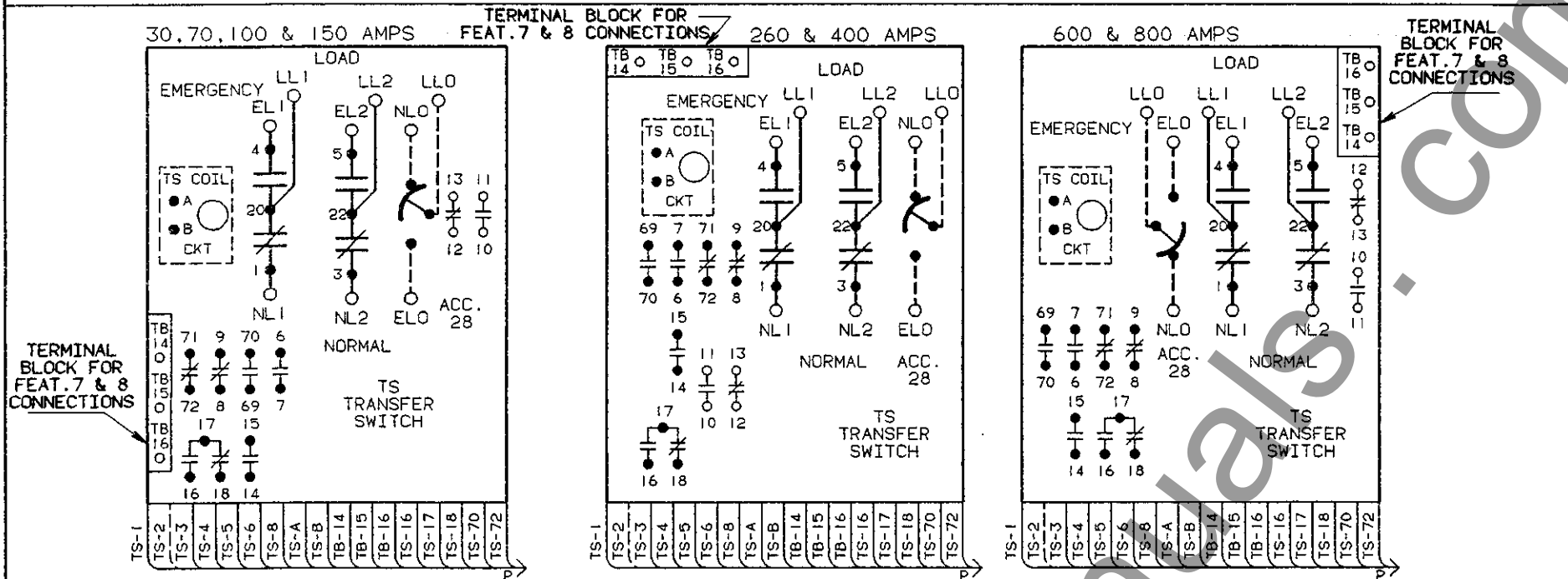

## STANDARD FEATURES

- VOLTAGE AND FREQUENCY SENSING**
- A. CLOSE DIFFERENTIAL VOLTAGE SENSING ON ONE PHASE OF NORMAL SOURCE. PICKUP VOLTAGE IS ADJUSTABLE FROM 85% TO 100% OF NOMINAL AND THE DROPOUT IS ADJUSTABLE FROM 75% TO 98% OF THE PICKUP VALUE. FACTORY SET TO PICKUP AT 90% AND DROPOUT AT 85% OF NOMINAL UNLESS OTHERWISE SPECIFIED. STANDARD FEATURE 4A.
  - B. SINGLE PHASE VOLTAGE SENSING OF EMERGENCY SOURCE. PICKUP ADJUSTABLE FROM 85% TO 100% OF NOMINAL. FACTORY SET TO PICKUP AT 90% UNLESS OTHERWISE SPECIFIED.
  - C. FREQUENCY SENSING OF EMERGENCY SOURCE. PICKUP ADJUSTABLE FROM 90% TO 100% OF NOMINAL. FACTORY SET TO PICKUP AT 95% UNLESS OTHERWISE SPECIFIED.
- TIME DELAYS**
- D. TIME DELAY TO OVERRIDE MOMENTARY NORMAL SOURCE OUTAGES TO DELAY ALL TRANSFER SWITCH AND ENGINE STARTING SIGNALS. ADJUSTABLE FROM 0.5 TO 6 SECONDS. FACTORY SET AT 1 SECOND UNLESS OTHERWISE SPECIFIED. STANDARD FEATURE 1.
  - E. RETRANSFER TO NORMAL TIME DELAY. TIME DELAY IS AUTOMATICALLY BYPASSED IF EMERGENCY SOURCE FAILS AND NORMAL SOURCE IS AVAILABLE. ADJUSTABLE FROM 0.5 TO 30 MINUTES. FACTORY SET AT 30 MINUTES UNLESS OTHERWISE SPECIFIED. STANDARD FEATURE 3A.
  - F. UNLOADED RUNNING TIME DELAY FOR EMERGENCY ENGINE GENERATOR COOLDOWN. ADJUSTABLE FROM 0 TO 5 MINUTES. FACTORY SET AT 5 MINUTES UNLESS OTHERWISE SPECIFIED. STANDARD FEATURE 2E.

- G. TRANSFER TO EMERGENCY TIME DELAY. ADJUSTABLE FROM 0 TO 1 MINUTE. FACTORY SET AT 0 MINUTES UNLESS OTHERWISE SPECIFIED. STANDARD FEATURE 2B.
- ENGINE CONTROL CONTACTS**
- H. A CONTACT THAT CLOSURES WHEN NORMAL SOURCE FAILS. GOLD PLATED CONTACTS FOR LOW VOLTAGE ENGINE SIGNALS OR OTHER CUSTOMER USE. RATED 10 AMPS, 32 VOLTS DC. STANDARD FEATURE 7.
  - J. A CONTACT THAT OPENS WHEN NORMAL SOURCE FAILS. GOLD PLATED CONTACTS FOR LOW VOLTAGE ENGINE START SIGNALS OR OTHER CUSTOMER USE. RATED 10 AMPS, 32 VOLTS DC. STANDARD FEATURE 8.
- MANUAL CONTROLS**
- K. TEST SWITCH TGL WITH GOLD PLATED LOW VOLTAGE CONTACTS TO MOMENTARILY SIMULATE NORMAL SOURCE FAILURE. INSTALLED AND CONNECTED ON DOOR OF ENCLOSED TYPE. SHIPPED LOOSE FOR OPEN TYPE. STANDARD FEATURE 5.
- INDICATORS**
- L. ONE AUXILIARY CONTACT CLOSED WHEN AUTOMATIC TRANSFER SWITCH IS CONNECTED TO NORMAL. NOTE: ADDITIONAL AUXILIARY CONTACTS ARE AVAILABLE AS OPTIONS. STANDARD FEATURE 14A.
  - M. ONE AUXILIARY CONTACT CLOSED WHEN AUTOMATIC TRANSFER SWITCH IS CONNECTED TO EMERGENCY. NOTE: ADDITIONAL AUXILIARY CONTACTS ARE AVAILABLE AS OPTIONS. STANDARD FEATURE 14B.
  - N. SIGNAL LIGHT PL1, INDICATES WHEN AUTOMATIC TRANSFER SWITCH IS CONNECTED TO NORMAL SOURCE. INSTALLED AND CONNECTED ON DOOR OF ENCLOSED TYPE. SHIPPED LOOSE FOR OPEN TYPE. STANDARD FEATURE 9A. REFER TO OPERATOR'S MANUAL FOR REPLACEMENT NUMBER. (GREEN)

## OPTIONAL ACCESSORIES

- MANUAL CONTROLS FOR AUTOMATIC TRANSFER SWITCH**
- 6A:** RESET SWITCH TO MANUALLY RETRANSFER THE AUTOMATIC TRANSFER SWITCH TO THE NORMAL SOURCE. GOLD PLATED LOW VOLTAGE CONTACTS. INSTALLED AND CONNECTED ON DOOR OF ENCLOSED TYPE. SHIPPED LOOSE OPEN TYPE.
  - 6B:** RESET SWITCH TO MANUALLY BYPASS TIME DELAY ON RETRANSFER TO NORMAL. GOLD PLATED LOW VOLTAGE CONTACTS. INSTALLED AND CONNECTED ON DOOR OF ENCLOSED TYPE. SHIPPED LOOSE FOR OPEN TYPE.
  - 6C:** RESET SWITCH TO MANUALLY RETRANSFER THE AUTOMATIC TRANSFER SWITCH TO THE NORMAL SOURCE AFTER TIME DELAY EXPIRES WITH AUTOMATIC RETRANSFER IN THE EVENT OF EMERGENCY SOURCE FAILURE. GOLD PLATED LOW VOLTAGE CONTACTS. INSTALLED AND CONNECTED ON DOOR OF ENCLOSED TYPE. SHIPPED LOOSE FOR OPEN TYPE.
- INDICATORS**
- 14A:** AUXILIARY CONTACT CLOSED WHEN AUTOMATIC TRANSFER SWITCH IS CONNECTED TO NORMAL SOURCE. ONE AUXILIARY IS SUPPLIED AS STANDARD. SPECIFY TOTAL QUANTITY WHEN MORE THAN ONE IS REQUIRED.
  - 14B:** AUXILIARY CONTACT CLOSED WHEN AUTOMATIC TRANSFER SWITCH IS CONNECTED TO EMERGENCY SOURCE. ONE AUXILIARY IS SUPPLIED AS STANDARD. SPECIFY TOTAL QUANTITY WHEN MORE THAN ONE IS REQUIRED.
- PLANT EXERCISERS**
- 11A:** ENGINE GENERATOR EXERCISING TIMER WITHOUT LOAD. ADJUSTABLE IN 15 MINUTE INCREMENTS. FACTORY SET FOR 20 MINUTES MINIMUM EACH WEEK UNLESS OTHERWISE SPECIFIED. ADDITIONAL ACC. MTG. PANEL IS REQUIRED.
  - 11B:** ENGINE GENERATOR EXERCISING TIMER WITH LOAD. ADJUSTABLE IN 15 MINUTE INCREMENTS. FACTORY SET FOR 20 MINUTES MINIMUM EACH WEEK UNLESS OTHERWISE SPECIFIED. ADDITIONAL ACC. MTG. PANEL IS REQUIRED.
- REMOTE AUTOMATIC TRANSFER SWITCH CIRCUITS**
- 17:** TERMINAL PROVISIONS FOR REMOTE CONTACT WHICH OPENS TO SIGNAL AUTOMATIC TRANSFER SWITCH TO TRANSFER TO EMERGENCY. SEE "AREA PROTECTION" IN ORDERING SECTION 8 OF ASCO CONTROLS CATALOG.

# TRANSFER SWITCHES

TERMINAL BLOCK FOR FEAT. 7 & 8 CONNECTIONS 1000 & 1200 AMPS

1600, 2000, 3000 & 4000 AMPS

IN-LINE DISCONNECT PLUG FOR INTERCONNECTING HARNESS.

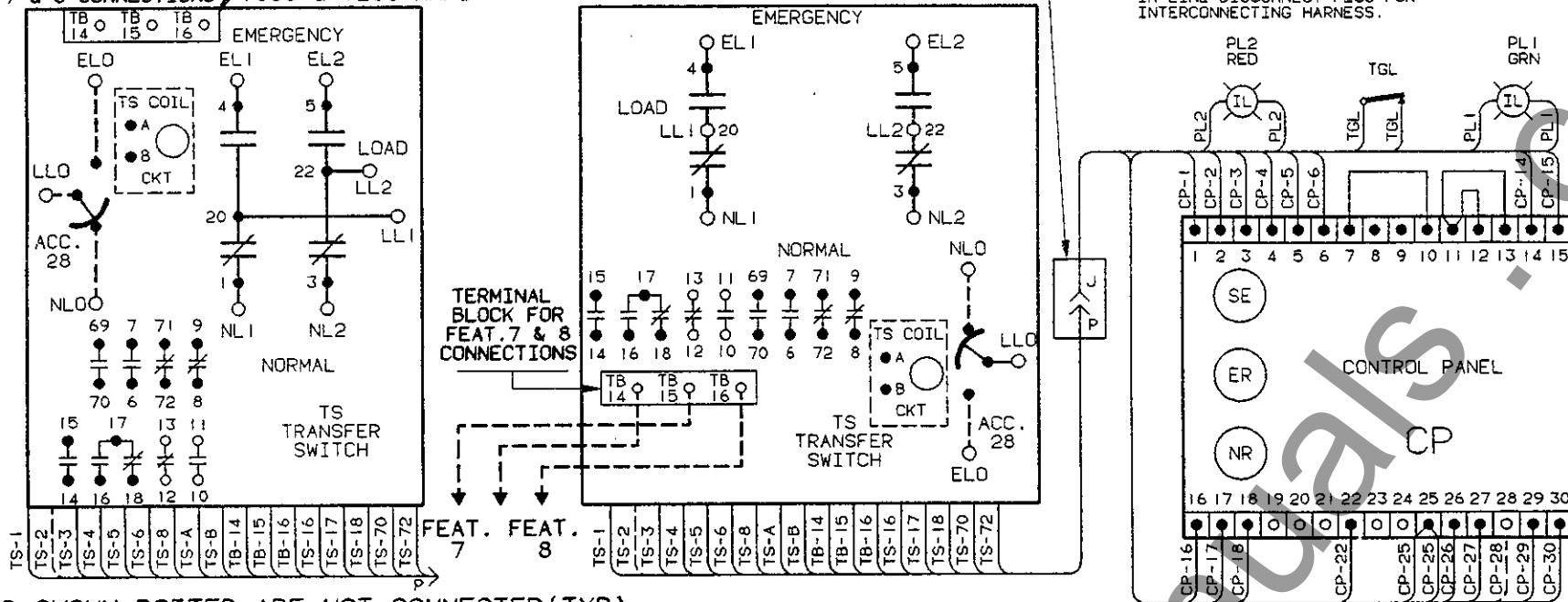

LEADS SHOWN DOTTED ARE NOT CONNECTED (TYP).

## ELEMENTARY WIRING DIAGRAM

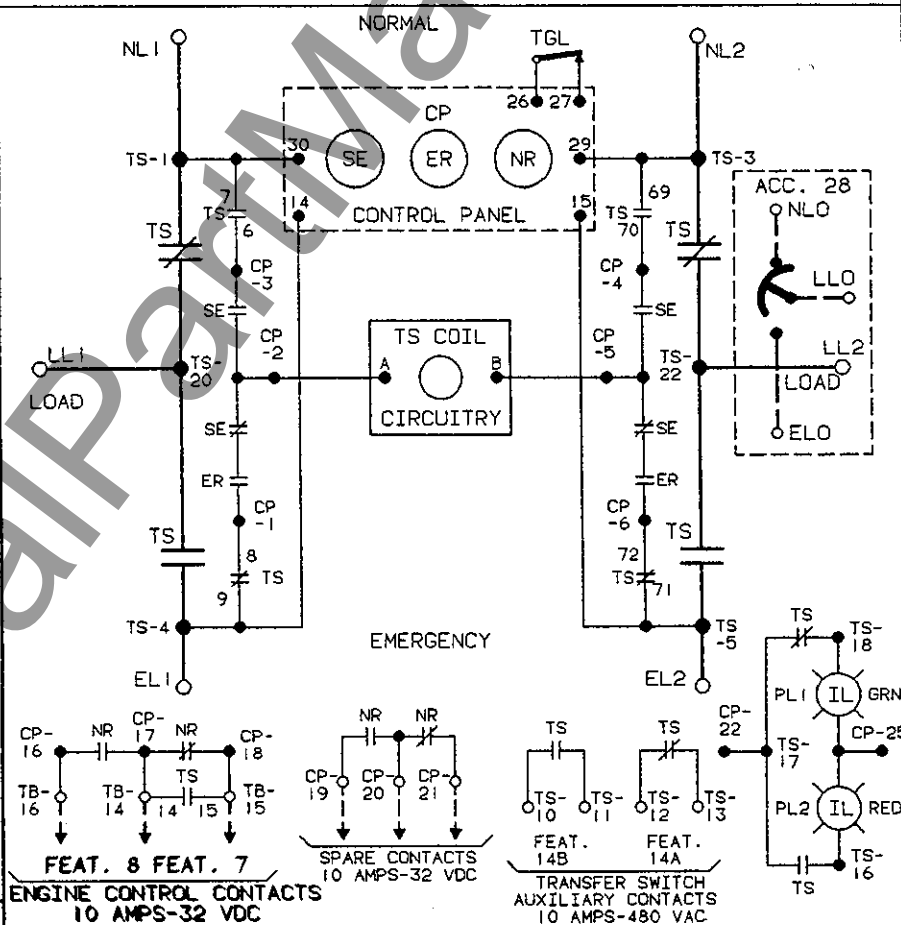

FEAT. 8 FEAT. 7  
ENGINE CONTROL CONTACTS  
10 AMPS-32 VDC

FEAT. 14B FEAT. 14A  
TRANSFER SWITCH  
AUXILIARY CONTACTS  
10 AMPS-480 VAC

COMPUTER GENERATED DRAWING

### MOTOR LOAD TRANSFER

- 27: INPHASE MONITOR CONTROLS FOR TRANSFER AND RETRANSFER OF MOTOR LOADS, SO THAT INRUSH CURRENTS DO NOT EXCEED NORMAL STARTING CURRENTS, TO AVOID NUISANCE TRIPPING OF CIRCUIT BREAKERS AND POSSIBLE MECHANICAL DAMAGE TO MOTOR COUPLINGS. SEE TRANSFERRING MOTOR LOADS IN TECHNICAL SECTION 1 OF ASCO CONTROLS CATALOG. ADDITIONAL ACC. MTG. PANEL IS REQUIRED.

### TRANSFER SWITCH OPTIONS

- 22: SOLID NEUTRAL, WITH FULL RATED TERMINALS. AL-CU, UL LISTED. SHIPPED LOOSE FOR OPEN TYPE.
- 28: OVERLAPPING NEUTRAL TRANSFER CONTACTS. ASSURES PROPER GROUND FAULT SENSING AND AVOIDS POSSIBLE PHASE OVERVOLTAGES DURING TRANSFER OF NEUTRAL BETWEEN NORMAL AND EMERGENCY. NOTE NORMAL AND EMERGENCY CONTACTS, ON ACC. 28 POLE ARE REVERSED ON 30-400 AMP AND 1600-4000 AMP SWITCHES. SEE "GROUND FAULT PROTECTION AND ASCO OPTIONAL ACC. 28" IN ORDERING SECTION 1 OF ASCO CONTROLS CATALOG.
- SEE ATTACHED SHEET FOR ADDITIONAL ACCESSORIES.

BASIC CATALOG NUMBERS	VOLT CODE	STD. ACC. CODE	OPT. ACC. CODE	ENCLOSURE CODE	VOLTAGE CODE DESCRIPTION OPERATING FREQ. 50-60 HZ
ASCO POLES AMPS					3 110 TO 120V
940 2	30 70 100 150 260 400 600 800 1000 1200 1600 2000 3000 4000	3 6 9 G X	8 X	TYPE 1 TYPE 2 TYPE 3R TYPE 4 TYPE 7 TYPE 12	6 120/240V 115/230V 9 190 TO 208V 220 TO 240V 440 TO 480V 437347/600V 550 TO 600V X OTHER VOLTAGES
					CATALOG NUMBER CERTIFIED
					TO <b>ASCO</b> S.O. _____
					DATE _____ BY _____

### COMPOSITE SINGLE PHASE ELEMENTARY DIAGRAM FOR ASCO 940 AUTOMATIC TRANSFER SWITCHES WITH GROUP 8 CONTROLS

BY	DATE	Automatic Switch Co.	E.R. NO.	ITEM CHGD.	CHG.	DATE	APVD.
DRAWN	PB	3/83	84344	SEE ER	F	10/84	FM
CHECKED	NS	3/83	83934	SEE ER	E	2/84	PDG
DFTG APL	FM	3/83	80283	SEE ER	D	5/83	PDG
ENG APL	PDG	3/83	78907	REDRAWN	C	3/83	PDG

FLORHAM PARK, N.J. 07932, PRINTED IN U.S.A.

PROPERTY OF AUTOMATIC SWITCH CO. USE PERMITTED FOR OUR WORK ONLY. ALL RIGHTS OF DESIGN OR INVENTION ARE RESERVED.

**JS 345-542**



### 30 THRU 150 AMPS

AMP SIZE	DIMENSIONS						
	A	B	C	D	E	F	G
30 TO 100	10.25	10.25	5.50	7.75	1.62	8.75	0.75
150	10.25	10.25	5.37	7.75	1.62	8.75	0.75
	H	J	K	L	V		
30 TO 100	3.48	0.73	2.09	0.31	0.79		
150	4.46	0.96	0.90	0.31	0.46		

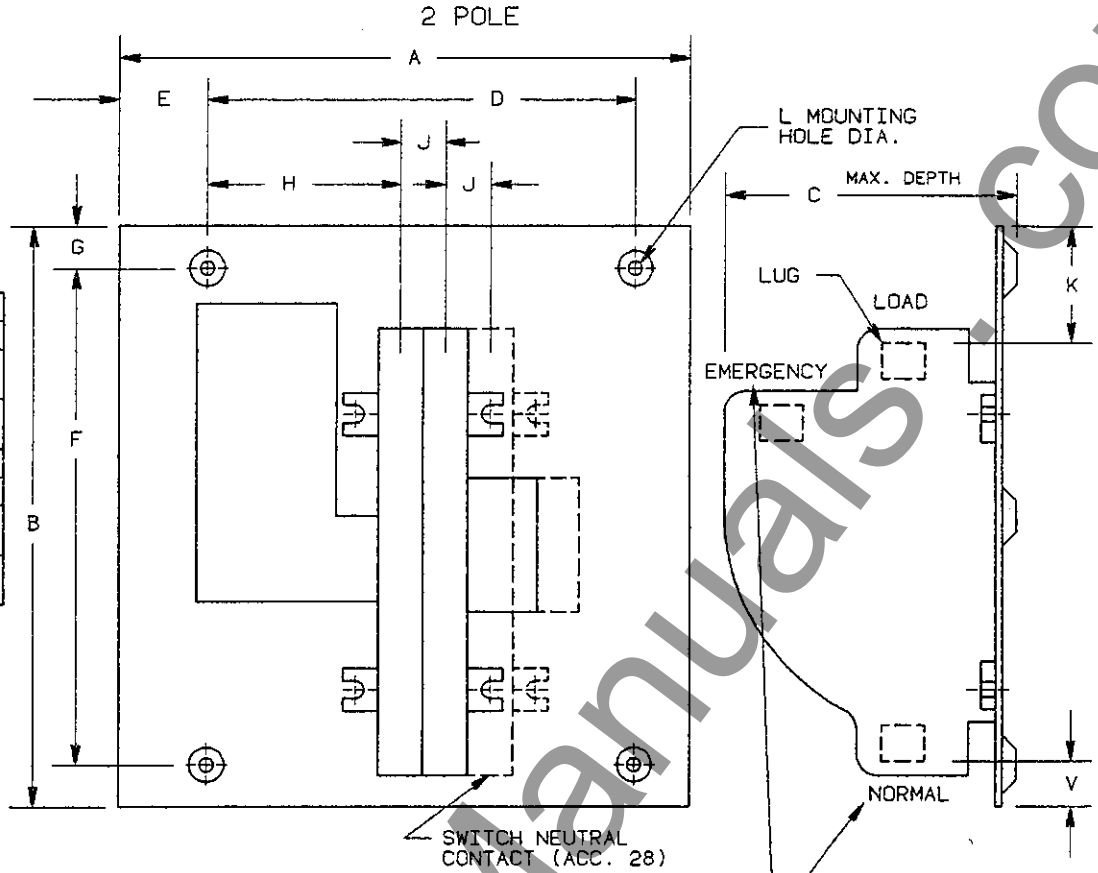

NORMAL & EMERGENCY CONTACTS, ON ACC. 28 POLE, ARE REVERSED

### 260 THRU 400 AMP.

**WARNING**  
SUPPLIED BACKING PIECE MUST BE INSTALLED ON ALL 400 AMP SWITCHES

STANDARD OVERHANG IS 2.00, 50.8 MM  
MAXIMUM OVERHANG IS 5.00, 127.0 MM WHEN ADDITIONAL AUXILIARY CONTACTS ARE SUPPLIED

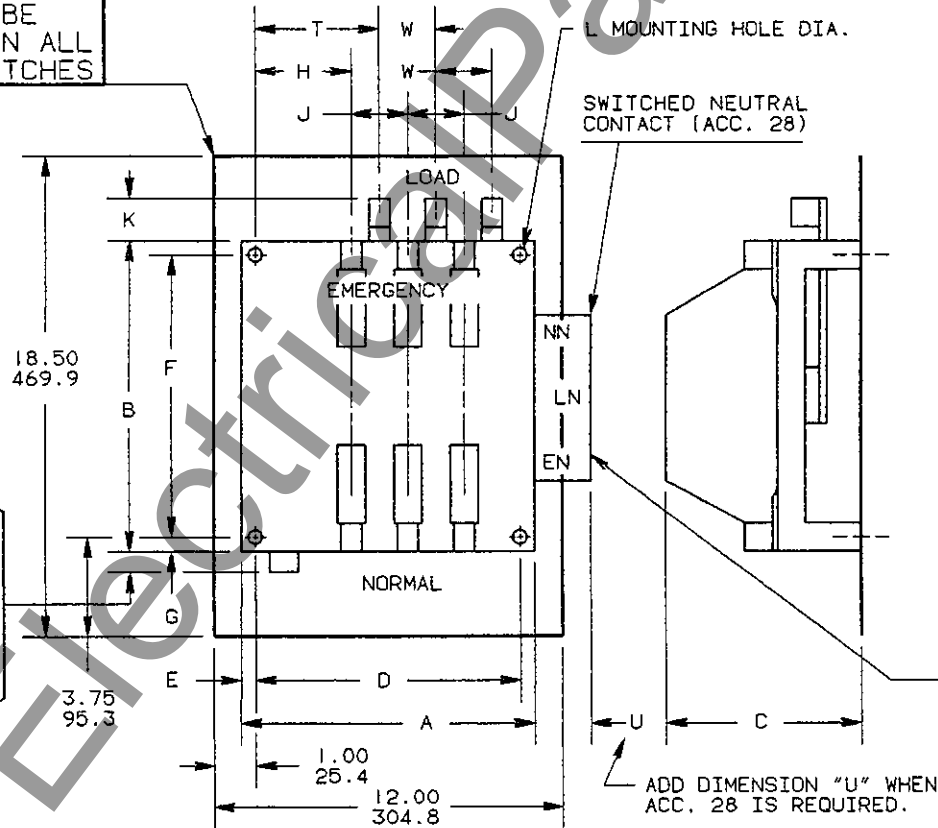

NORMAL & EMERGENCY CONTACTS, ON ACC. 28 POLE, ARE REVERSED

2 AND 3 POLE WITH AND WITHOUT ACC. 28

AMP SIZE	DIMENSIONS													
	A	B	C	D	E	F	G	H	J	K	L	T	U	W
260	11.00	12.00	5.87	10.00	0.50	11.00	0.50	3.87	2.12	1.50	0.31	4.93	2.62	2.12
	279.4	304.8	149.1	254.0	12.7	279.4	12.7	98.3	53.8	38.1	Ø7.9	125.2	66.5	53.8
400	11.00	12.00	6.87	10.00	0.50	11.00	0.50	3.87	2.12	2.12	0.31	4.93	3.00	2.12
	279.4	304.8	174.5	254.0	12.7	279.4	12.7	98.3	53.8	53.8	Ø7.9	125.2	76.2	53.8

# 30 THRU 150 AMPS

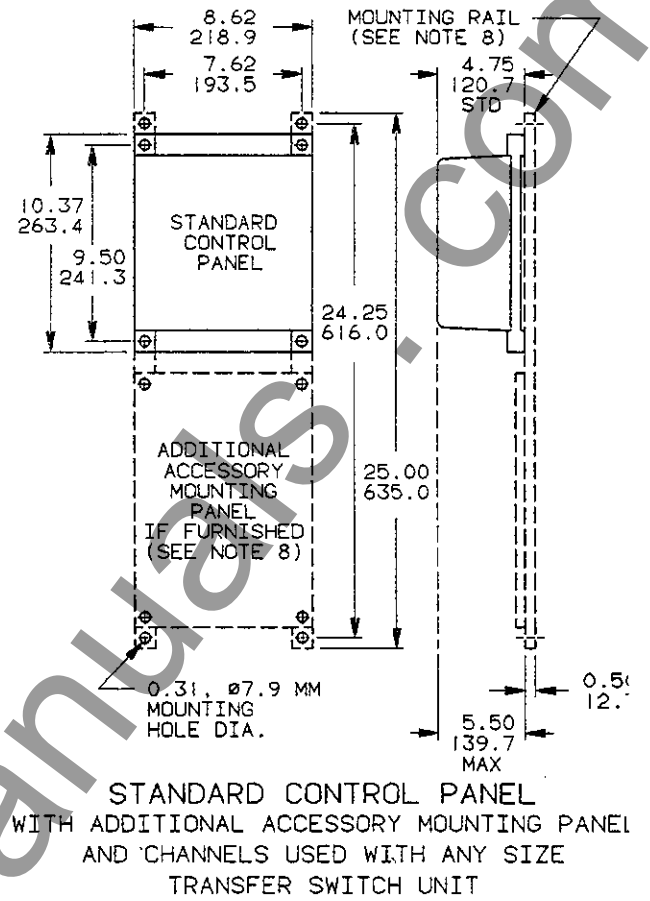
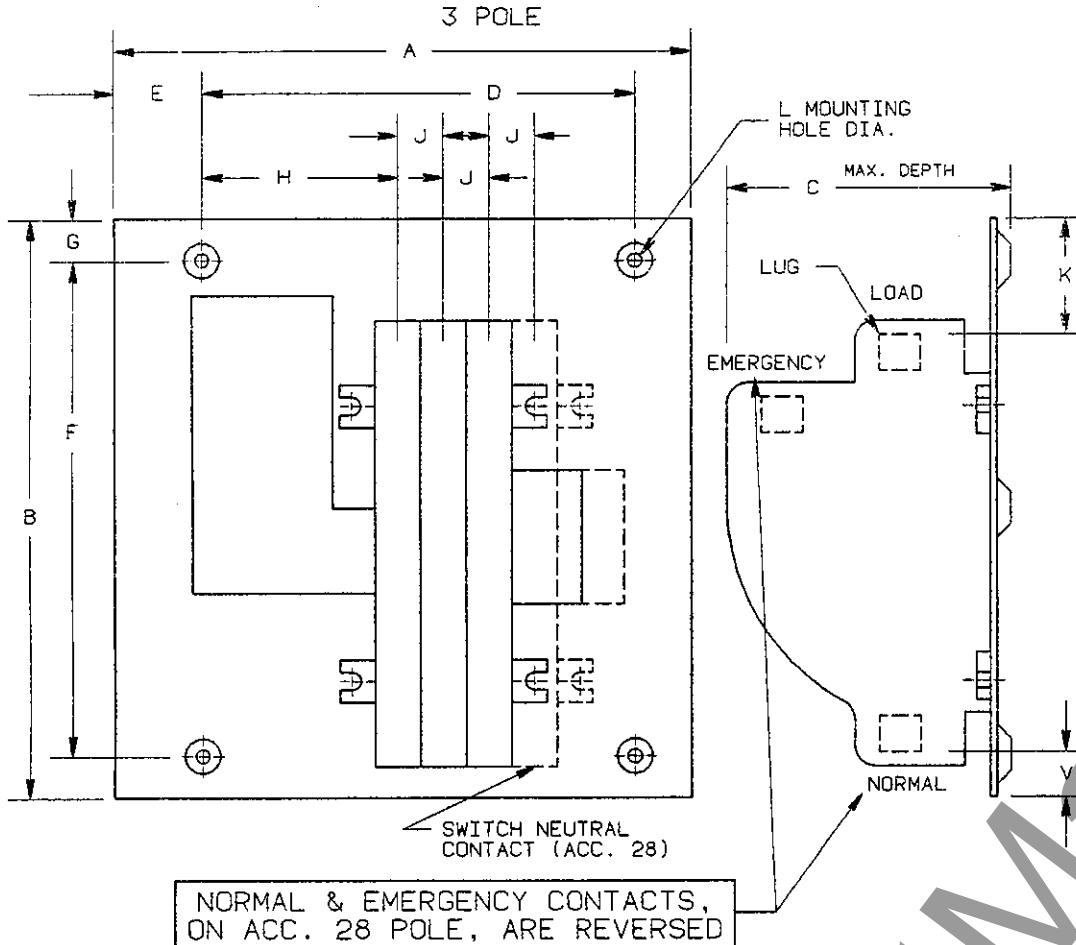

## GENERAL NOTES

- FOR 260 AND 400 AMP TWO POLE SWITCHES, OMIT CENTER POLE.
- WHEN INSTALLING, CONNECT NORMAL, EMERGENCY, AND LOAD CONDUCTORS TO SIMILARLY MARKED TERMINALS.
- ALL INTERNAL CONNECTIONS ARE MADE AT THE FACTORY
- MAINTAIN ELECTRICAL CLEARANCE OF 0.50, 12.7 MM. MINIMUM BETWEEN LIVE METAL PARTS AND GROUNDED METAL.
- LOAD LUGS CAN BE FACTORY ASSEMBLED FOR OPTIONAL BOTTOM CONNECTIONS, ON 260 AMP SWITCHES.
- WHEN OPEN TYPE ATS'S ARE INTENDED FOR ENCLOSURE TYPE MOUNTING BY OTHERS, MOUNT THE TRANSFER SWITCH UNIT ON THE INSIDE BACK SURFACE AND THE CONTROL PANEL(S) ON THE INSIDE DOOR SURFACE.
- THE CONTROL PANEL IS CONNECTED TO THE TRANSFER SWITCH PANEL BY TWO WIRE HARNESES IN A COMMON INLINE QUICK DISCONNECT PLUG. TOTAL HARNESS LENGTH IS 36.00, 914.4 MM. CONSULT FACTORY FOR AVAILABLE EXTENSION HARNESES.
- OPTIONAL ACCESSORY MOUNTING PANEL AND RAILS ARE SUPPLIED ON OPEN TYPE SWITCHES FOR MOUNTING OPTIONAL TIME DELAYS, RELAYS, AND MONITORS.
- PUBLICATION 1D4800 OPERATOR'S MANUAL IS FURNISHED WITH EACH AUTOMATIC TRANSFER SWITCH. REFER TO THIS PUBLICATION PRIOR TO INSTALLATION AND OPERATION OF THE SWITCH.

DRILL PATTERN BELOW WILL ACCOMMODATE MOST DOOR MOUNTED ACCESSORIES. REFER TO ASCO SUPPLIED ACCESSORY NAMEPLATE DRAWING FOR ACTUAL DOOR DRILLING REQUIREMENTS.

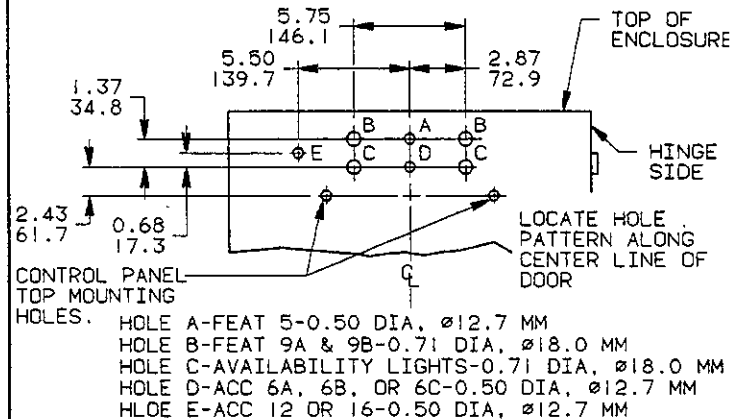

## SIZES OF UL LISTED SOLDERLESS SCREW TYPE TERMINALS FOR EXTERNAL POWER CONNECTIONS

SWITCH RATING (AMPS)	RANGE OF AL-CU WIRE SIZE
30	ONE #14 TO #6 AWG
70	ONE #14 TO 1/0 AWG
100	ONE #14 TO 2/0 AWG
150	ONE #8 TO 3/0 AWG
* 260	ONE #4 AWG TO 400 MCM
* 400	TWO #1/0 AWG TO 250 MCM OR ONE #4 AWG TO 600 MCM

\* CONTACT FACTORY FOR BUS CONNECTION DRAWINGS

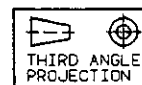
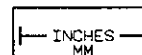

CATALOG NO. \_\_\_\_\_  
CERTIFIED

To **ASCA**® s. o. \_\_\_\_\_

DATE \_\_\_\_\_ BY \_\_\_\_\_

COMPUTER GENERATED DRAWING

**Automatic Switch Co.®**

FLORHAM PARK, NEW JERSEY, 07932  
PRINTED IN U.S.A.

BY	DATE	PROPERTY OF AUTOMATIC SWITCH CO.
DRAWN JTT	3/83	USE PERMITTED FOR OUR WORK ONLY.
CHECKED NS	3/83	ALL RIGHTS OF DESIGN OR INVENTION ARE RESERVED.
DFTG APVL FM	3/83	
ENGR APVL PDG	3/83	AL <input checked="" type="checkbox"/> AP <input checked="" type="checkbox"/>

**COMPOSITE OUTLINE AND MOUNTING DIMENSIONS FOR OPEN TYPE 30 THROUGH 400 AMPERE ASCA® 940 AUTOMATIC TRANSFER SWITCHES 2 & 3 POLE WITH OR WITHOUT ACC. 28 OVERLAPPING NEUTRAL TRANSFER CONTACT**

ER NO	ITEM	CHGD	CHG	DATE	AP
83934	SEE E.R.	E		2/84	PI
82303	SEE E.R.	D		12/83	PI
78907	REDRAWN	C		3/83	PI
<b>JS345-538</b>					
CHG LTR	E				

## 600 THRU 800 AMP

AMP SIZE	DIMENSIONS						
	A	B	C	D	E	F	G
600	19.25 489.0	25.00 635.0	11.00 279.4	18.37 466.6	0.43 10.9	7.50 190.5	1.25 31.8
800	19.25 489.0	25.00 635.0	11.00 279.4	18.37 466.6	0.43 10.9	7.50 190.5	1.25 31.8
1000 & 1200	19.62 498.3	30.00 762.0	13.00 330.2	18.87 479.3	0.37 9.4	31.25 793.8	0.62 15.7

AMP SIZE	DIMENSIONS						
	H	J	K	L	M	N	P
600	7.00 177.8	3.37 85.6	1.75 44.5	0.50 12.7	—	—	—
800	6.87 174.5	3.50 88.9	1.75 44.5	0.50 12.7	—	—	—
1000 & 1200	7.50 190.5	4.28 108.7	5.06 128.5	0.43 10.9	11.87 301.5	32.50 825.5	1.37 34.8

AMP SIZE	DIMENSIONS			
	R	S	T	W
600	—	—	5.31 134.9	3.37 85.6
800	—	—	5.12 130.0	3.50 88.9
1000 & 1200	3.18 80.8	12.62 320.5	—	3.68 93.5

APPROXIMATE SHIPPING WEIGHT				
AMPERES	POLES	WEIGHT	POLES	WEIGHT
600	2	125 (57)	3	135 (62)
800	2	135 (62)	3	145 (66)
1000	2	280 (127)	3	300 (136)
1200	2	300 (136)	3	320 (145)
1600	2	355 (161)	3	385 (175)
2000	2	355 (161)	3	385 (175)
3000	2	750 (340)	3	900 (409)
4000	2	975 (443)	3	1200 (545)

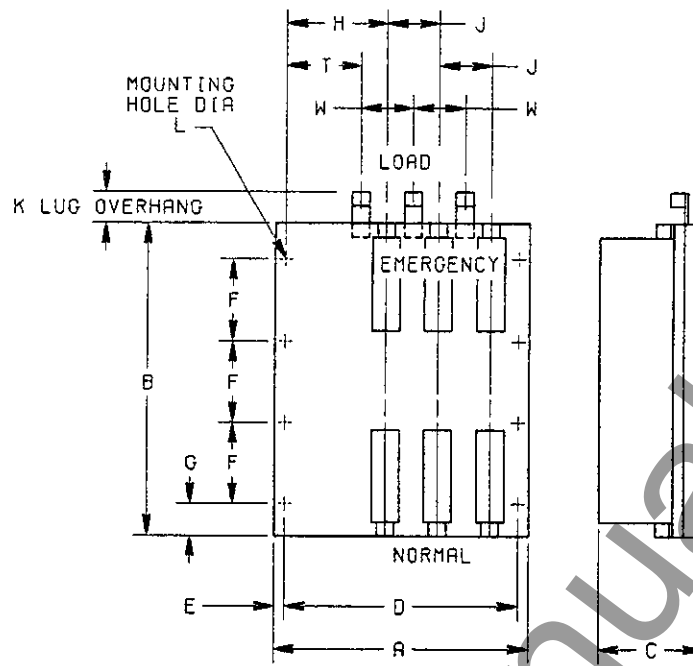

## 1600 THRU 4000 AMP

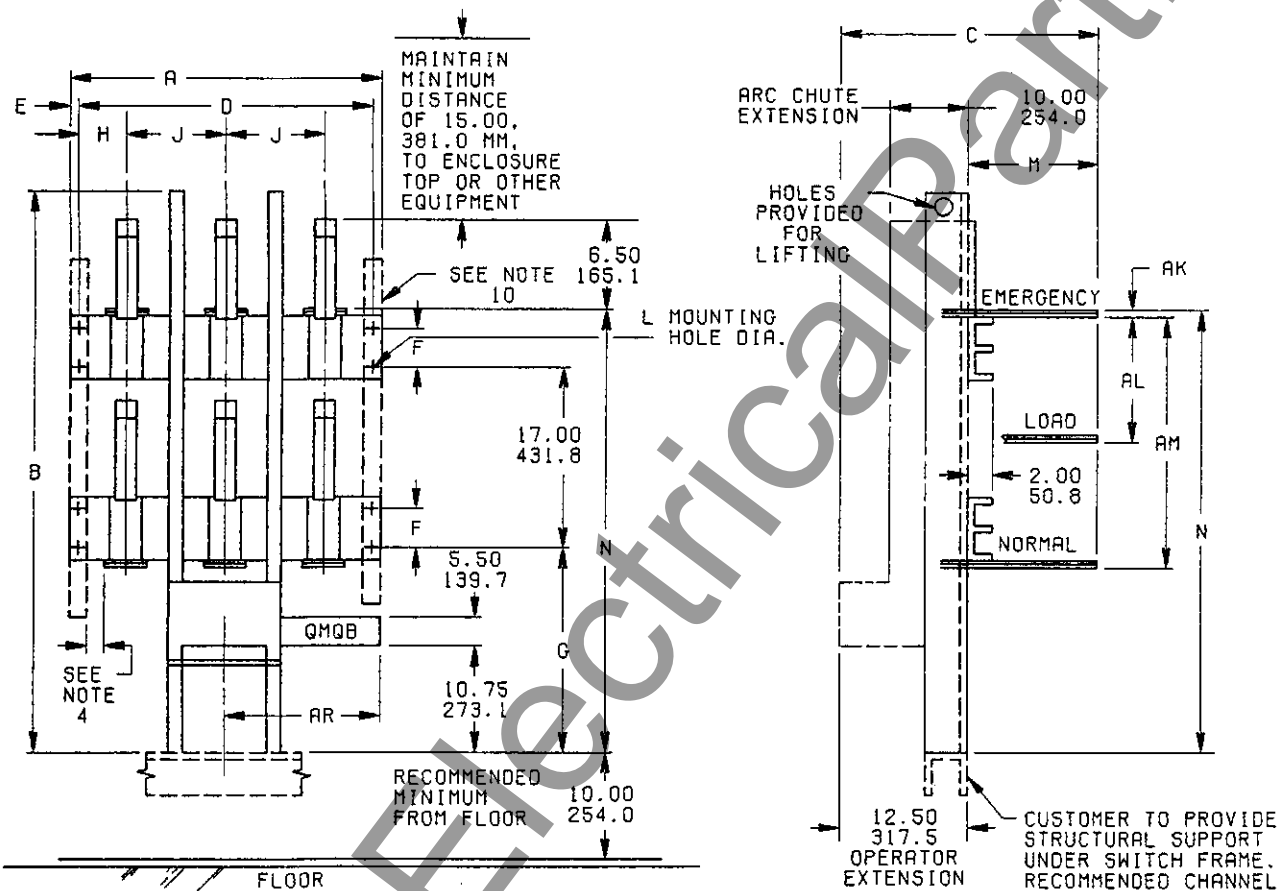

AMP SIZE	DIMENSIONS								
	A	B	C	D	E	F	G	H	J
1600 & 2000	28.50 723.9	52.00 1320.8	18.50 469.9	27.00 685.8	0.75 19.1	4.37 111.0	20.65 524.5	4.50 114.3	9.00 228.6
3000	31.50 800.1	52.00 1320.8	22.50 571.5	30.00 762.0	0.75 19.1	4.37 111.0	20.65 524.5	5.00 127.0	10.00 254.0
4000	41.00 1041.4	52.00 1320.8	25.50 647.7	39.00 990.6	1.00 25.4	4.37 111.0	20.65 524.5	6.50 165.1	13.00 330.2

AMP SIZE	DIMENSIONS						
	L	M	N	AK	AL	AM	AR
1600 & 2000	0.40 10.2	6.00 152.4	43.46 1103.9	0.50 12.7	11.62 295.1	23.75 603.3	—
3000	0.40 10.2	10.00 254.0	43.71 1110.4	0.75 19.1	11.75 298.5	24.00 609.6	20.50 520.7
4000	0.40 10.2	13.00 330.2	43.71 1110.4	0.75 19.1	11.75 298.5	24.00 609.6	19.50 495.3

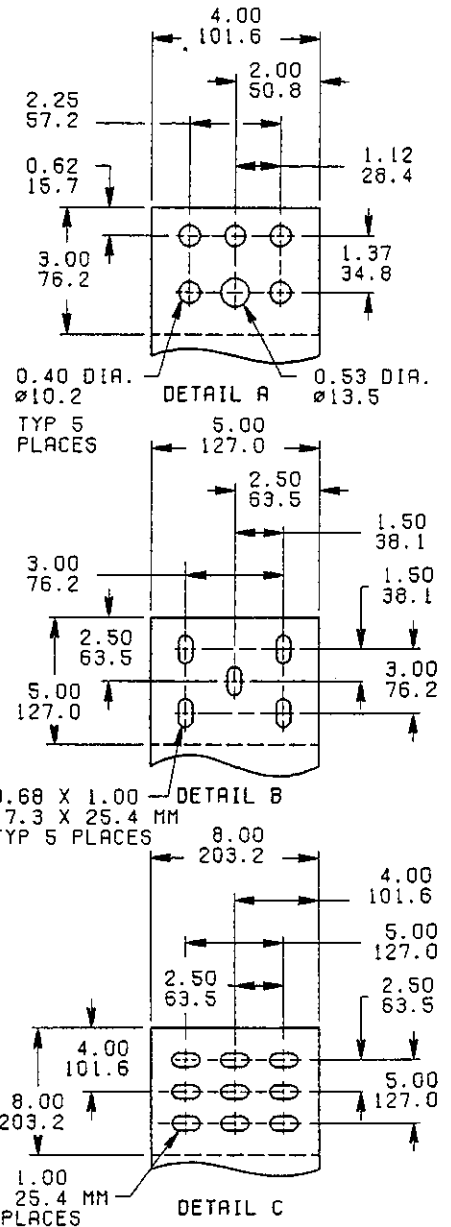

AMP SIZE	BUS BAR PER PHASE BOLTING SURFACE
1600 & 2000	TWO 0.25 X 4.00, 6.4 X 101.6 MM SEE DETAIL "A"
3000	TWO 0.37 X 5.00, 9.4 X 127.0 MM SEE DETAIL "B"
4000	TWO 0.37 X 8.00, 9.4 X 203.2 MM SEE DETAIL "C"

# 1000 THRU 1200 AMP

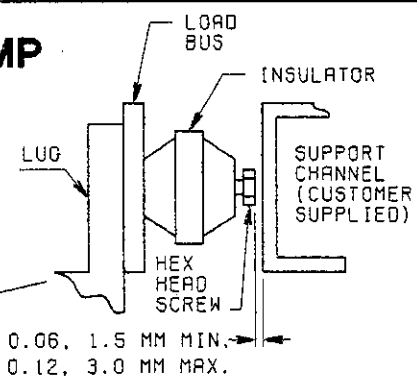
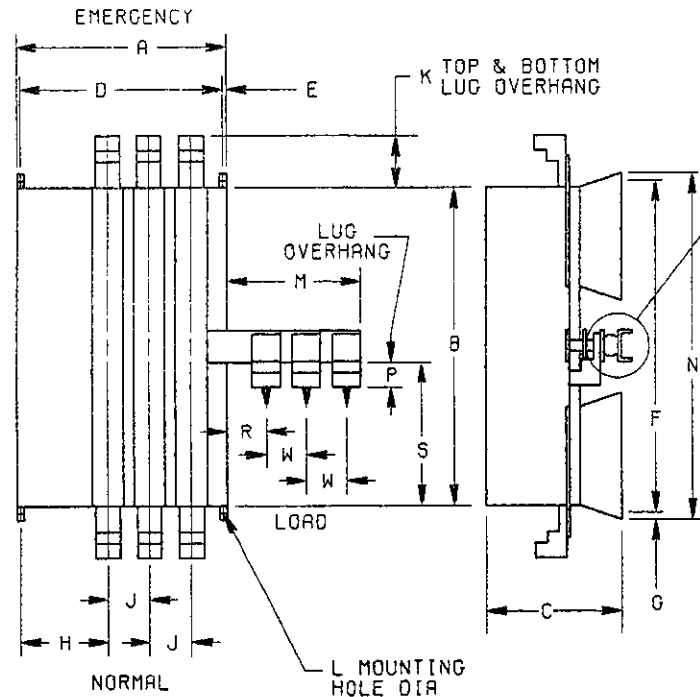

**IMPORTANT NOTE:**  
 WHEN MOUNTED IN OTHER THAN CONVENTIONAL CABINET, SUCH AS A CUBICLE, A CUSTOMER SUPPLIED SUPPORT CHANNEL IS REQUIRED AND MUST BE MOUNTED AND LOCATED IN THE CUBICLE BETWEEN THE LOAD BUS AND THE CUBICLE BACK. THIS WILL PREVENT THE LOAD BUS FROM BENDING UNDER HIGH FAULT CURRENT CONDITIONS. AN INSULATOR IS MOUNTED ON THE LOAD BUS. DO NOT FASTEN THE INSULATOR TO THE CHANNEL. A HEX HEAD SCREW IS SUPPLIED ON ONE END OF THE INSULATOR. IT MAY BE ADJUSTED TO BUILD UP THE INSULATOR LENGTH OR COMPLETELY REMOVED TO ATTAIN AN INSTALLED CLEARANCE OF 0.06, 1.5 MM MIN TO 0.12, 3.0 MM MAX.

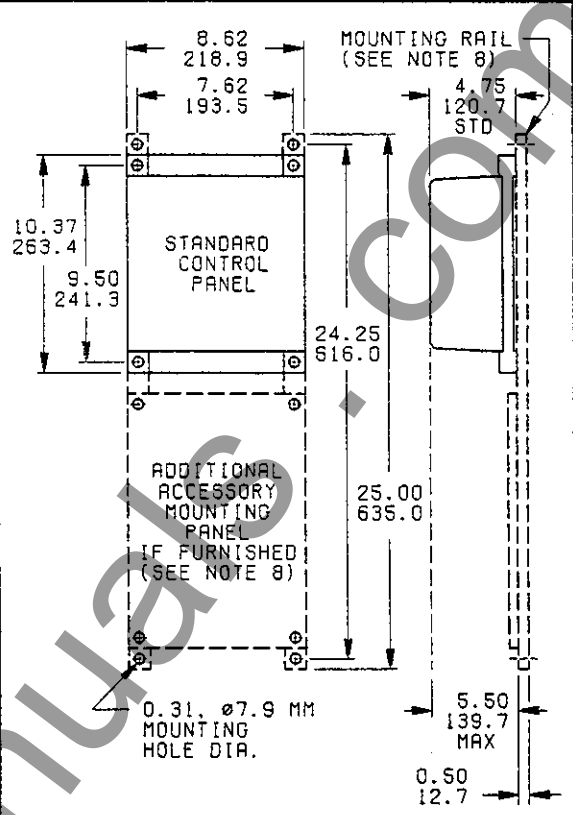

STANDARD CONTROL PANEL WITH ADDITIONAL ACCESSORY MOUNTING PANEL AND CHANNELS USED WITH ANY SIZE TRANSFER SWITCH UNIT

## GENERAL NOTES

- FOR TWO POLE SWITCHES, OMIT CENTER POLE.
- WHEN INSTALLING, CONNECT NORMAL, EMERGENCY, AND LOAD CONDUCTORS TO SIMILARLY MARKED TERMINALS.
- ALL INTERNAL CONNECTIONS ARE MADE AT THE FACTORY.
- MAINTAIN ELECTRICAL CLEARANCE OF 1.00, 25.4 MM. MINIMUM BETWEEN LIVE METAL PARTS AND GROUNDED METAL.
- WHEN OPEN TYPE ATS'S ARE INTENDED FOR ENCLOSURE TYPE MOUNTING BY OTHERS, MOUNT THE TRANSFER SWITCH UNIT ON THE INSIDE BACK SURFACE AND THE CONTROL PANEL(S) ON THE INSIDE DOOR SURFACE.
- THE CONTROL PANEL IS CONNECTED TO THE TRANSFER SWITCH PANEL BY TWO WIRE HARNESSSES IN A COMMON IN-LINE QUICK DISCONNECT PLUG. TOTAL HARNESS LENGTHS- 50.00, 1270.0 MM FOR 600-800 AMPS, 60.00, 1524.0 MM FOR 1000-1200 AMPS, AND 96.00, 2438.4 MM FOR 1600-4000 AMPS. CONSULT FACTORY FOR AVAILABLE EXTENSION HARNESSSES.
- REQUIRED FRONT TOP AND BOTTOM ENCLOSURE VENTILATION OPENINGS FOR 1600 THRU 4000 AMP SWITCHES IS 140 SQ. INCHES 903 SQ. CM TOTAL.
- OPTIONAL ACCESSORY MOUNTING PANEL AND RAILS ARE SUPPLIED ON OPEN TYPE SWITCHES FOR MOUNTING OPTIONAL TIME DELAYS, RELAYS, AND MONITORS.
- OPERATOR'S MANUAL 104800 IS FURNISHED WITH EACH AUTOMATIC TRANSFER SWITCH. REFER TO THIS PUBLICATION PRIOR TO INSTALLATION AND OPERATION OF THE SWITCH.
- CUSTOMER SUPPLIED VERTICAL MOUNTING CHANNELS (2) REQUIRED (MINIMUM GAUGE #10)

DRILL PATTERN BELOW WILL ACCOMMODATE MOST DOOR MOUNTED ACCESSORIES. REFER TO ASCO SUPPLIED ACCESSORY NAMEPLATE DRAWING FOR ACTUAL DOOR DRILLING REQUIREMENTS.

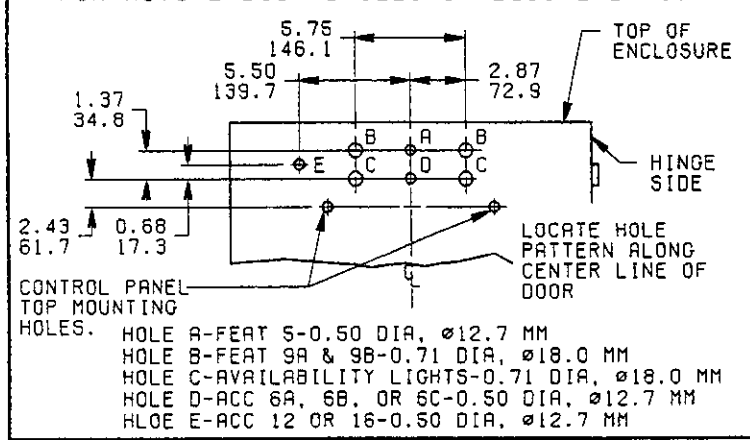

- HOLE A-FEAT 5-0.50 DIA,  $\phi$ 12.7 MM
- HOLE B-FEAT 9A & 9B-0.71 DIA,  $\phi$ 18.0 MM
- HOLE C-AVAILABILITY LIGHTS-0.71 DIA,  $\phi$ 18.0 MM
- HOLE D-ACC 6A, 6B, OR 6C-0.50 DIA,  $\phi$ 12.7 MM
- HOLE E-ACC 12 OR 16-0.50 DIA,  $\phi$ 12.7 MM

### SIZES OF UL LISTED SOLDERLESS SCREW TYPE TERMINALS FOR EXTERNAL POWER CONNECTIONS

SWITCH RATING (AMPS)	RANGE OF AL-CU WIRE SIZES
* 600	TWO #2 AWG TO 600 MCM
* 800	THREE #2 AWG TO 600 MCM
* 1000-1200	FOUR #2 AWG TO 600 MCM
1600-4000	SUITABLE FOR BUS BAR

\* CONTACT FACTORY FOR BUS CONNECTION DRAWINGS

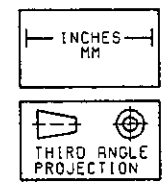

CATALOG NO. \_\_\_\_\_  
 CERTIFIED  
 To **ASCO**® s. o. \_\_\_\_\_  
 DATE \_\_\_\_\_ BY \_\_\_\_\_

COMPUTER GENERATED DRAWING

**Automatic Switch Co.**  
 FLOHAM PARK, NEW JERSEY, 07932  
 PRINTED IN U.S.A.

BY	DATE	PROPERTY OF AUTOMATIC SWITCH CO. USE PERMITTED FOR OUR WORK ONLY. ALL RIGHTS OF DESIGN OR INVENTION ARE RESERVED.
DRANN	JTF 3/83	
CHECKED	NS 3/83	
DFTG APVL	FM 3/83	
ENGR APVL	POG 3/83	

## COMPOSITE OUTLINE AND MOUNTING DIMENSIONS FOR OPEN TYPE 600 THROUGH 4000 AMPERE ASCO® 940 AUTOMATIC TRANSFER SWITCHES 2 & 3 POLE WITHOUT ACC. 28 OVERLAPPING NEUTRAL TRANSFER CONTACT

90398	SEE E.R.	G	8/85	FM	
88618	SEE E.R.	F	4/85	FM	
93934	SEE E.R.	E	5/84	POG	
82303	SEE E.R.	D	12/83	POG	
79845	SEE E.R.	C	4/83	POG	
78907	REDRAWN	B	3/83	POG	
ER NO	ITEM	CHGO	CHG	DATE	APVL
<b>JS345-539</b>					
CHG LTR	G				

AMP SIZE	DIMENSIONS							
	A	B	C	D	E	F	G	H
600 & 800	22.75 577.8	25.00 635.0	11.00 279.4	21.87 555.5	0.43 10.9	7.50 190.5	1.25 31.8	6.87 174.5
1000 & 1200	25.00 635.0	30.00 762.0	13.00 330.2	24.25 616.0	0.37 9.4	31.25 793.8	0.62 15.7	3.06 77.7

AMP SIZE	DIMENSIONS							
	J	K	L	M	N	P	R	S
600 & 800	3.50 88.9	1.75 44.5	0.50 12.7	—	—	—	—	—
1000 & 1200	4.28 108.7	5.06 128.5	0.43 10.9	11.87 301.5	32.50 825.5	1.37 34.8	3.18 80.8	12.62 320.5

AMP SIZE	DIMENSIONS							
	T	U	V	W	X	Y	Z	AR
600 & 800	5.12 130.0	—	—	3.50 88.9	—	—	—	—
1000 & 1200	—	2.62 66.5	2.25 57.2	3.68 93.5	7.12 180.8	2.62 66.5	1.37 34.8	11.31 287.3

APPROXIMATE SHIPPING WEIGHT				
AMPERES	POLES	WEIGHT	POLES	WEIGHT
600	2	135 (62)	3	145 (66)
800	2	145 (66)	3	155 (71)
1000	2	300 (136)	3	320 (145)
1200	2	320 (145)	3	340 (155)
1600	2	385 (175)	3	410 (186)
2000	2	385 (175)	3	410 (186)
3000	2	850 (386)	3	1000 (454)
4000	2	1000 (454)	3	1300 (590)

## 600 THRU 800 AMP

SWITCHED NEUTRAL CONTACT (ACC. 28)

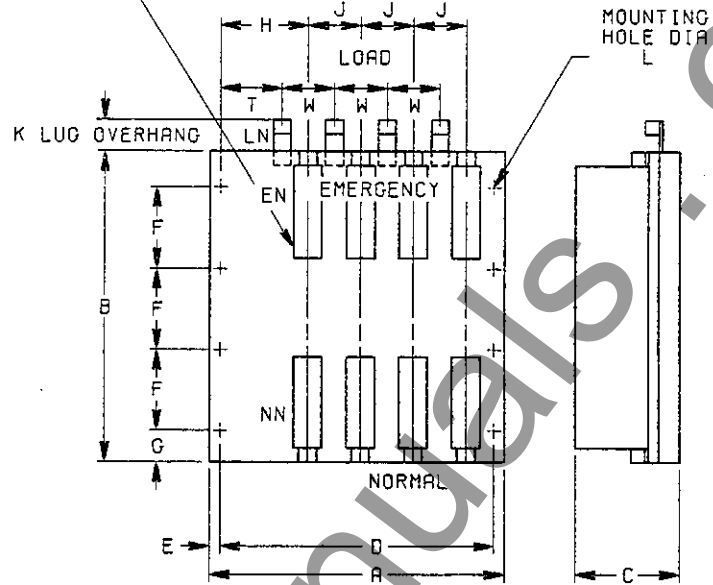

## 1600 THRU 4000 AMP

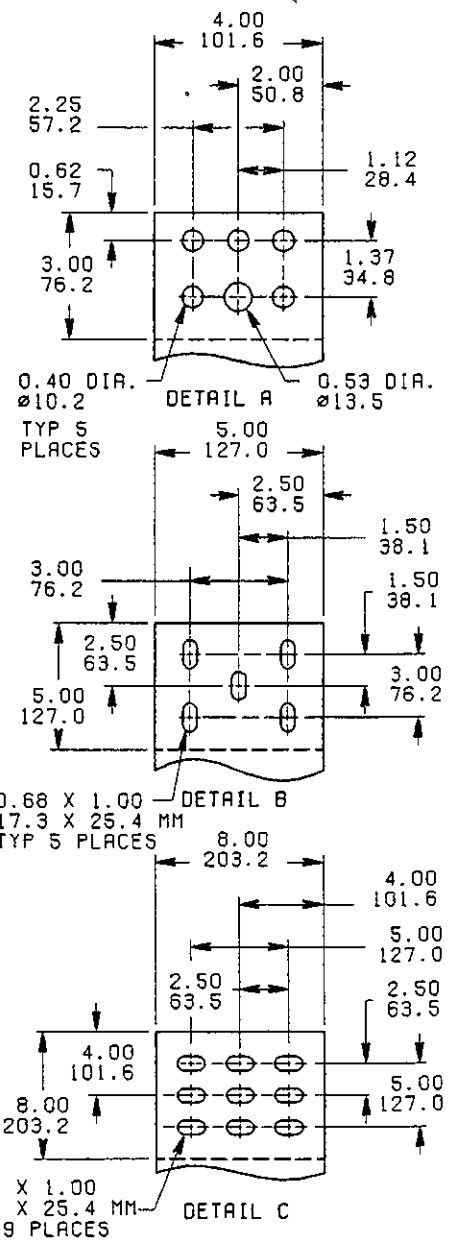
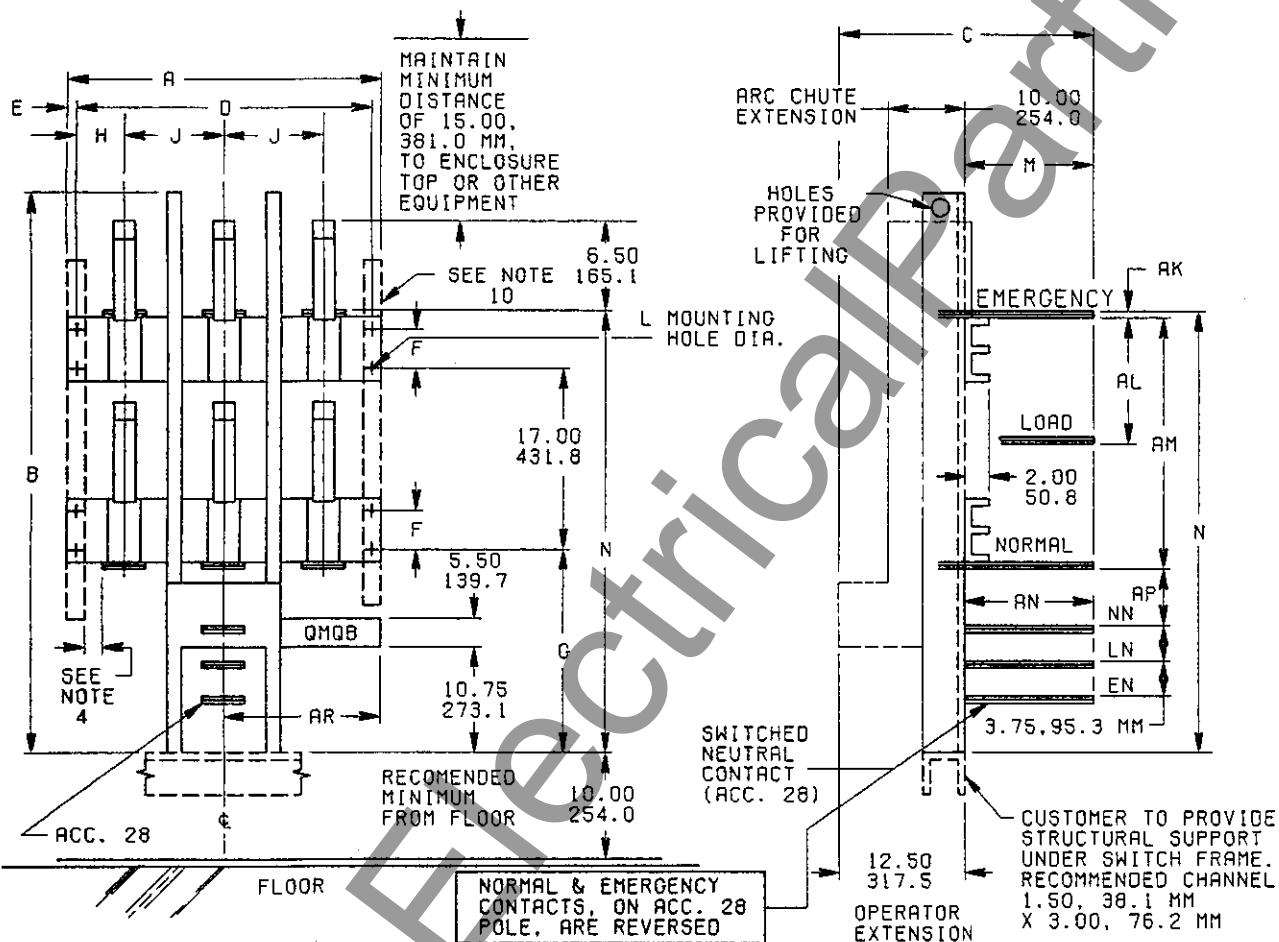

AMP SIZE	DIMENSIONS									
	A	B	C	D	E	F	G	H	J	
1600 & 2000	28.50 723.9	52.00 1320.8	18.50 469.9	27.00 685.8	0.75 19.1	4.37 111.0	20.65 524.5	4.50 114.3	9.00 228.6	
3000	31.50 800.1	52.00 1320.8	22.50 571.5	30.00 762.0	0.75 19.1	4.37 111.0	20.65 524.5	5.00 127.0	10.00 254.0	
4000	41.00 1041.4	52.00 1320.8	25.50 647.7	39.00 990.6	1.00 25.4	4.37 111.0	20.65 524.5	6.50 165.1	13.00 330.2	

AMP SIZE	DIMENSIONS								
	L	M	N	AK	AL	AM	AN	AP	AR
1600 & 2000	0.40 10.2	6.00 152.4	43.46 1103.9	0.50 12.7	11.62 295.1	23.75 603.3	6.00 152.4	8.03 204.0	—
3000	0.40 10.2	10.00 254.0	43.71 1110.4	0.75 19.1	11.75 298.5	24.00 609.6	10.00 254.0	8.41 213.7	20.50 520.7
4000	0.40 10.2	13.00 330.2	43.71 1110.4	0.75 19.1	11.75 298.5	24.00 609.6	13.00 330.2	8.41 213.7	19.50 495.3

AMP SIZE	BUS BAR PER PHASE BOLTING SURFACE
1600 & 2000	TWO 0.25 X 4.00, 6.4 X 101.6 MM SEE DETAIL "A"
3000	TWO 0.37 X 5.00, 9.4 X 127.0 MM SEE DETAIL "B"
4000	TWO 0.37 X 8.00, 9.4 X 203.2 MM SEE DETAIL "C"

# 1000 THRU 1200 AMP

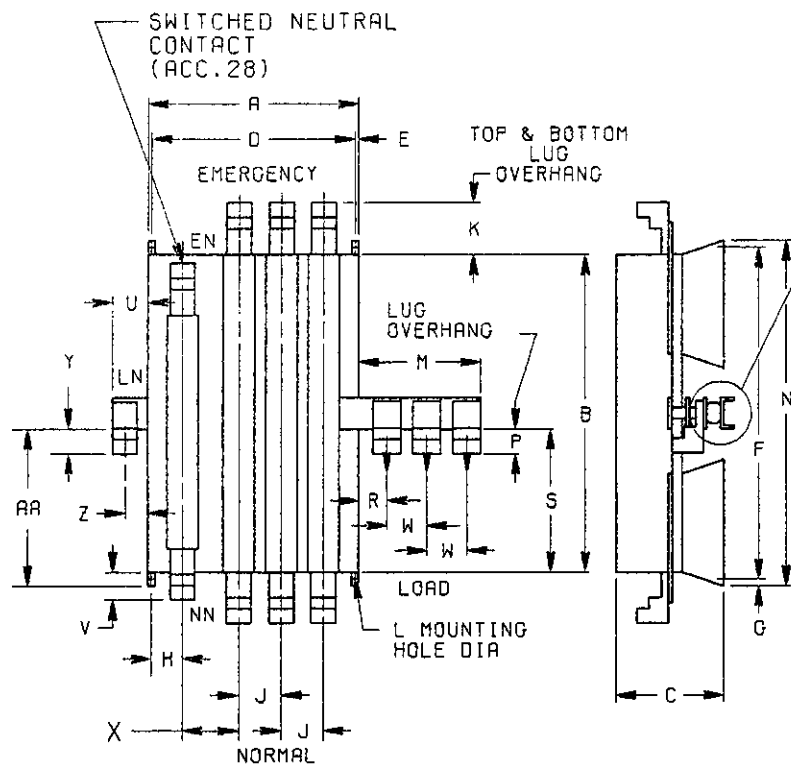

**IMPORTANT NOTE:**  
 WHEN MOUNTED IN OTHER THAN CONVENTIONAL CABINET, SUCH AS A CUBICLE, A CUSTOMER SUPPLIED SUPPORT CHANNEL IS REQUIRED AND MUST BE MOUNTED AND LOCATED IN THE CUBICLE BETWEEN THE LOAD BUS AND THE CUBICLE BACK. THIS WILL PREVENT THE LOAD BUS FROM BENDING UNDER HIGH FAULT CURRENT CONDITIONS. AN INSULATOR IS MOUNTED ON THE LOAD BUS. DO NOT FASTEN THE INSULATOR TO THE CHANNEL, A HEX HEAD SCREW IS SUPPLIED ON ONE END OF THE INSULATOR. IT MAY BE ADJUSTED TO BUILD UP THE INSULATOR LENGTH OR COMPLETELY REMOVED TO ATTAIN AN INSTALLED CLEARANCE OF 0.06, 1.5 MM MIN TO 0.12, 3.0 MM MAX.

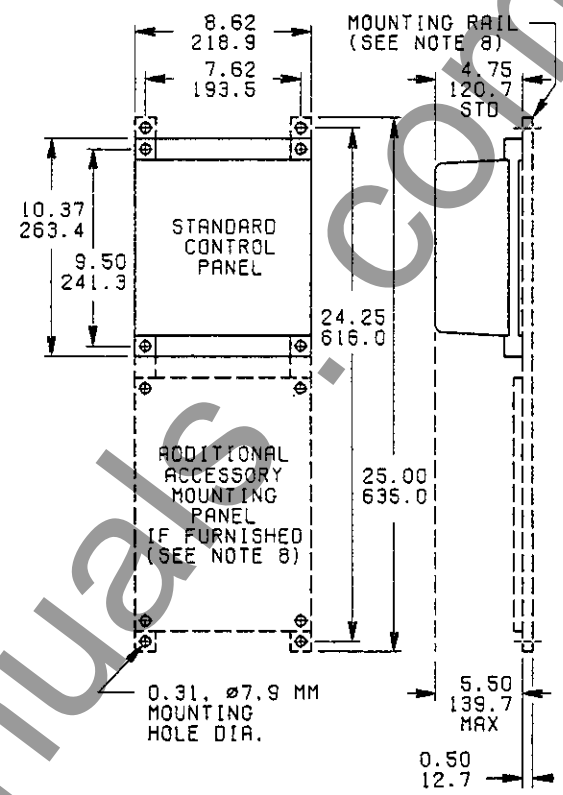

STANDARD CONTROL PANEL WITH ADDITIONAL ACCESSORY MOUNTING PANEL AND CHANNELS USED WITH ANY SIZE TRANSFER SWITCH UNIT

## GENERAL NOTES

- FOR TWO POLE SWITCHES, OMIT CENTER POLE.
- WHEN INSTALLING, CONNECT NORMAL, EMERGENCY, AND LOAD CONDUCTOR TO SIMILARLY MARKED TERMINALS.
- ALL INTERNAL CONNECTIONS ARE MADE AT THE FACTORY.
- MAINTAIN ELECTRICAL CLEARANCE OF 1.00, 25.4 MM. MINIMUM BETWEEN LIVE METAL PARTS AND GROUNDED METAL.
- WHEN OPEN TYPE ATS'S ARE INTENDED FOR ENCLOSURE TYPE MOUNTING BY OTHERS, MOUNT THE TRANSFER SWITCH UNIT ON THE INSIDE BACK SURFACE AND THE CONTROL PANEL(S) ON THE INSIDE DOOR SURFACE.
- THE CONTROL PANEL IS CONNECTED TO THE TRANSFER SWITCH PANEL BY TWO WIRE HARNESSES IN A COMMON IN-LINE QUICK DISCONNECT PLUG. TOTAL HARNESS LENGTHS- 50.00, 1270.0 MM FOR 600-800 AMPS, 60.00, 1524.0 MM FOR 1000-1200 AMPS, AND 96.00, 2438.4 MM FOR 1600-4000 AMPS. CONSULT FACTORY FOR AVAILABLE EXTENSION HARNESSES.
- REQUIRED TOP AND BOTTOM ENCLOSURE VENTILATION OPENINGS FOR 1600 THRU 4000 AMP SWITCHES IS 140 SQ. INCHES, 903 SQ. CM TOTAL.
- OPTIONAL ACCESSORY MOUNTING PANEL AND RAILS ARE SUPPLIED ON OPEN TYPE SWITCHES FOR MOUNTING OPTIONAL TIME DELAYS, RELAYS, AND MONITORS.
- OPERATOR'S MANUAL 104800 IS FURNISHED WITH EACH AUTOMATIC TRANSFER SWITCH. REFER TO THIS PUBLICATION PRIOR TO INSTALLATION AND OPERATION OF THE SWITCH.
- CUSTOMER SUPPLIED VERTICAL MOUNTING CHANNELS (2) REQUIRED (MINIMUM GAUGE #10)

DRILL PATTERN BELOW WILL ACCOMODATE MOST DOOR MOUNTED ACCESSORIES. REFER TO ASCO SUPPLIED DOOR ACCESSORY NAMEPLATE DRAWING FOR ACTUAL DOOR DRILLING REQUIREMENTS.

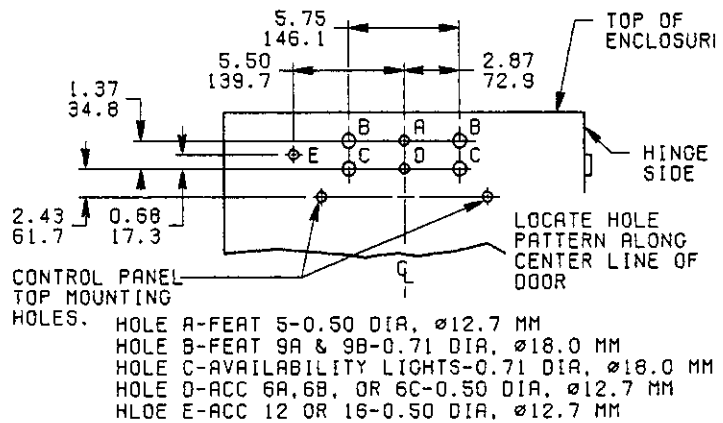

SIZES OF UL LISTED SOLDERLESS SCREW TYPE TERMINALS FOR EXTERNAL POWER CONNECTIONS

SWITCH RATING (AMPS)	RANGE OF AL-CU WIRE SIZES
* 600	TWO #2 AWG TO 600 MCM
* 800	THREE #2 AWG TO 600 MCM
* 1000-1200	FOUR #2 AWG TO 600 MCM
1600-4000	SUITABLE FOR BUS BAR

\* CONTACT FACTORY FOR BUS CONNECTION DRAWINGS

CATALOG NO. \_\_\_\_\_  
 CERTIFIED  
 TO ASCO® s. o. \_\_\_\_\_  
 DATE \_\_\_\_\_ BY \_\_\_\_\_

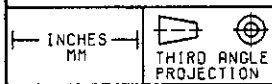

COMPUTER GENERATED DRAWING

**Automatic Switch Co.®**  
 FLORHAM PARK, NEW JERSEY, 07932  
 PRINTED IN U.S.A.

BY	DATE	PROPERTY OF AUTOMATIC SWITCH CO. USE PERMITTED FOR OUR WORK ONLY. ALL RIGHTS OF DESIGN OR INVENTION ARE RESERVED.
DRAWN	JTF 3/83	
CHECKED	NS 3/83	
DFTG APVL	FM 3/83	
ENGR APVL	POG 3/83	AL ☐ AP ☐

**COMPOSITE OUTLINE AND MOUNTING DIMENSIONS FOR OPEN TYPE 600 THROUGH 4000 AMPERE ASCO® 940 AUTOMATIC TRANSFER SWITCHES 2 & 3 POLE WITH ACC. 28 OVERLAPPING NEUTRAL TRANSFER CONTACT**

CHG LTR	H	ITEM	CHGD	CHG	DATE	AP
90398	SEE ER	H			8/85	FI
88618	SEE ER	G			4/85	FI
85400	SEE ER	F			5/84	PI
93934	SEE ER	E			5/84	PI
82303	SEE ER	D			12/83	PI
80299	SEE ER	C			7/83	PI
78907	REDRAWN	B			3/83	PI
<b>JS 345-540</b>						

DRIP SHIELD SUPPLIED ONLY ON NEMA TYPE 2 ENCLOSURES. 1.00, 25.4 MM, OVERHANG FRONT AND SIDES.

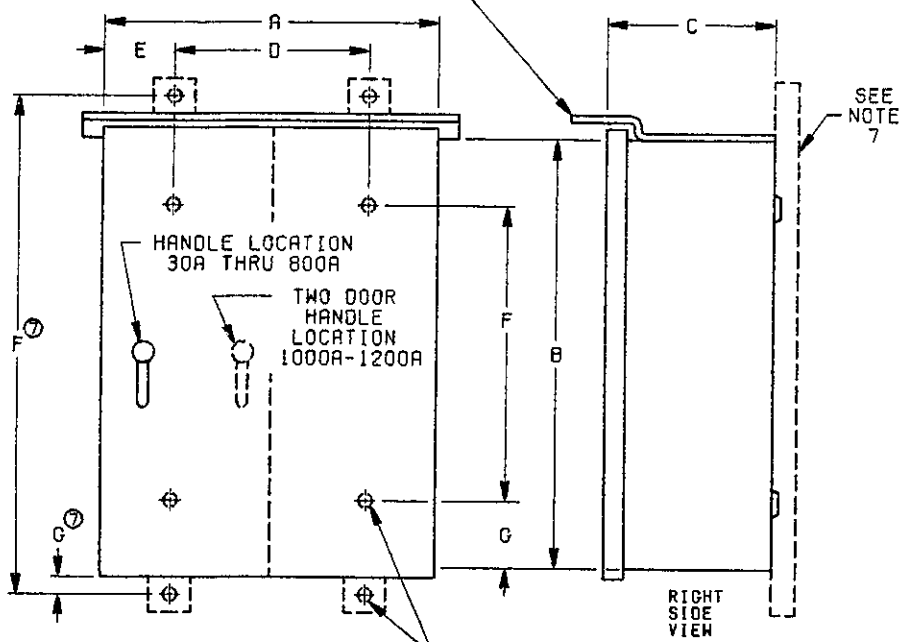

FIGURE 1  
NOTES  
(FIGURE 1 ONLY)

- ① ② ④ ⑥ ⑦ NEMA TYPE 1
- ① ② ⑤ ⑦ NEMA TYPE 2

1. REMOVABLE DOORS, KEY LOCKING HANDLE. SINGLE DOOR HINGED ON RIGHT SIDE WITH SINGLE CENTER LATCH AND CAPTIVE SCREWS ON TOP AND BOTTOM FOR 30 THRU 800 AMPS. TWO DOOR WITH 3 POINT LATCH ON 1000 THRU 1200 AMPS.
2. FULL WIRING GUTTERS AND 0.75-0.50 DIA,  $\varnothing$ 19.1- $\varnothing$ 12.7 MM, COMBINATION PILOT KNOCKOUTS PROVIDED TOP AND BOTTOM ONLY.
3. NEMA TYPE 1 CAN BE SUPPLIED WITH GASKETING TO PROVIDE A DUST SEAL.
4. FLUSH MOUNTED TYPES HAVE REMOVABLE FLUSH DOOR AND TRIM. TRIM OVERLAPS 1.00, 25.4 MM, ON ALL SIDES.
5. NEMA TYPE 2 ENCLOSURES ARE PROVIDED WITH A TOP MOUNTED DRIP SHIELD THAT EXTENDS BEYOND THE FRONT AND SIDES OF THE ENCLOSURE. PILOT KNOCKOUT PROVIDED IN BOTTOM ONLY.
6. ADD 3.00, 76.2 MM, FOR FLUSH MOUNTED ENCLOSURES.
7. EXTERNAL MOUNTING CHANNELS WITH MOUNTING HOLES FOR 1000-1200 AMPS ONLY. (SHOWN DASHED)

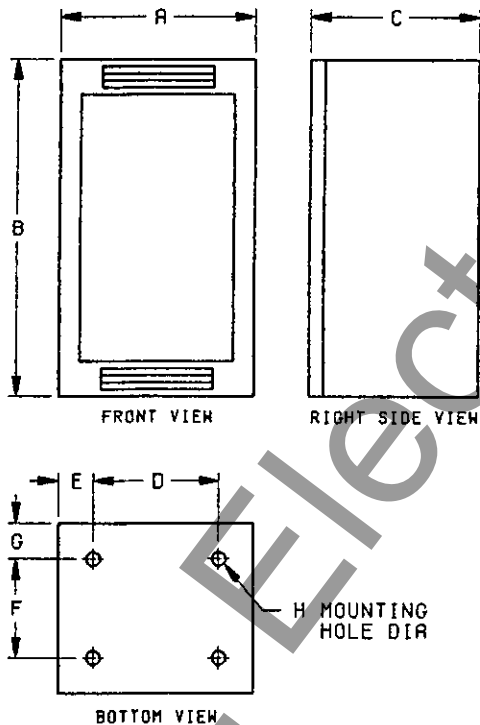

FIGURE 2  
NOTES  
(FIGURE 2 ONLY)

- NEMA TYPE 1-GENERAL PURPOSE, INDOOR, FLOOR SUPPORTED
1. FREE STANDING, FRAME CONSTRUCTION.
  2. REMOVABLE DOORS, KEY LOCKING HANDLE. SINGLE DOOR HINGED ON RIGHT WITH SINGLE CENTER LATCH AND CAPTIVE SCREWS ON TOP AND BOTTOM FOR 1600-2000 AMPS. TWO DOOR WITH 3 POINT LATCH ON 3000-4000 AMPS.
  3. SIDES, TOP, AND BACK REMOVABLE, OPEN BOTTOM.
  4. VENTILATED FRONT, ON TOP AND BOTTOM.
  5. PROVISIONS FOR LIFTING.

NEMA TYPE 1 AND 2 ENCLOSURES  
FOR  
ASCO AUTOMATIC TRANSFER SWITCHES WITHOUT  
ACC. 28 OVERLAPPING NEUTRAL TRANSFER CONTACT

AMP SIZE	FIG NO	DIMENSIONS						
		A	B	C	D	E	F	
30 TO 150	1	17.50 ⑥	31.00 ⑥	11.62	14.50	1.50	28.00	
		444.5	787.4	295.1	368.3	38.1	711.2	
260 TO 400		18.00 ⑥	48.00 ⑥	13.00	15.00	1.50	45.00	
		457.2	1219.2	330.2	381.0	38.1	1143.0	
600 TO 800		24.00	63.00	17.50	21.00	1.50	60.00	
		609.6	1600.2	444.5	533.4	38.1	1524.0	
1000 TO 1200	36.00	79.00	16.00	32.25	1.87	82.00 ⑦		
	914.4	2006.6	406.4	818.2	47.5	2082.8		
1600 TO 2000	2	38.00	90.00	48.00	33.50	2.25	41.75	
		965.2	2286.0	1219.2	850.9	57.2	1060.5	
3000 TO 4000		46.00	90.00	48.00	41.50	2.25	41.75	
		1168.4	2286.0	1219.2	1054.1	57.2	1060.5	
30 TO 150		1	1.50	0.37				
			38.1	$\varnothing$ 9.4				
260 TO 400	1.50		0.37					
	38.1		$\varnothing$ 9.4					
600 TO 800	1.50		0.37					
	38.1		$\varnothing$ 9.4					
1000 TO 1200	1.50 ⑦	0.68						
	38.1	$\varnothing$ 17.3						
1600 TO 2000	2	3.12	0.50					
		79.2	$\varnothing$ 12.7					
3000 TO 4000		3.12	0.50					
		79.2	$\varnothing$ 12.7					

NEMA TYPE 1 AND 2 ENCLOSURES  
FOR  
ASCO AUTOMATIC TRANSFER SWITCHES WITH  
ACC. 28 OVERLAPPING NEUTRAL TRANSFER CONTACT

AMP SIZE	FIG NO	DIMENSIONS						
		A	B	C	D	E	F	
30 TO 150	1	17.50 ⑥	31.00 ⑥	11.62	14.50	1.50	28.00	
		444.5	787.4	295.1	368.3	38.1	711.2	
260 TO 400		18.00 ⑥	48.00 ⑥	13.00	15.00	1.50	45.00	
		457.2	1219.2	330.2	381.0	38.1	1143.0	
600 TO 800		30.00	63.00	17.50	27.00	1.50	60.00	
		762.0	1600.2	444.5	685.8	38.1	1524.0	
1000 TO 1200	44.00	79.00	16.00	33.75	5.12	82.00 ⑦		
	1117.6	2006.6	406.4	857.3	130.0	2082.8		
1600 TO 2000	2	38.00	90.00	48.00	33.50	2.25	41.75	
		965.2	2286.0	1219.2	850.9	57.2	1060.5	
3000 TO 4000		46.00	90.00	48.00	41.50	2.25	41.75	
		1168.4	2286.0	1219.2	1054.1	57.2	1060.5	
30 TO 150		1	1.50	0.37				
			38.1	$\varnothing$ 9.4				
260 TO 400	1.50		0.37					
	38.1		$\varnothing$ 9.4					
600 TO 800	1.50		0.37					
	38.1		$\varnothing$ 9.4					
1000 TO 1200	1.50 ⑦	0.68						
	38.1	$\varnothing$ 17.3						
1600 TO 2000	2	3.12	0.50					
		79.2	$\varnothing$ 12.7					
3000 TO 4000		3.12	0.50					
		79.2	$\varnothing$ 12.7					

SIZES OF UL LISTED SOLDERLESS SCREW TYPE TERMINALS FOR EXTERNAL POWER CONNECTIONS

SWITCH RATING (AMPS)	RANGE OF AL-CU WIRE SIZES
30	ONE #14 TO #6 AWG
70	ONE #14 TO 1/0 AWG
100	ONE #14 TO 2/0 AWG
150	ONE #8 TO 3/0 AWG
260	ONE #4 AWG TO 400 MCM
400	TWO #1/0 AWG TO 250 MCM OR ONE #4 AWG TO 600 MCM
600	TWO #2 AWG TO 600 MCM
800	THREE #2 AWG TO 600 MCM
1000-1200	FOUR #2 AWG TO 600 MCM
1600-4000	SUITABLE FOR BUS BAR

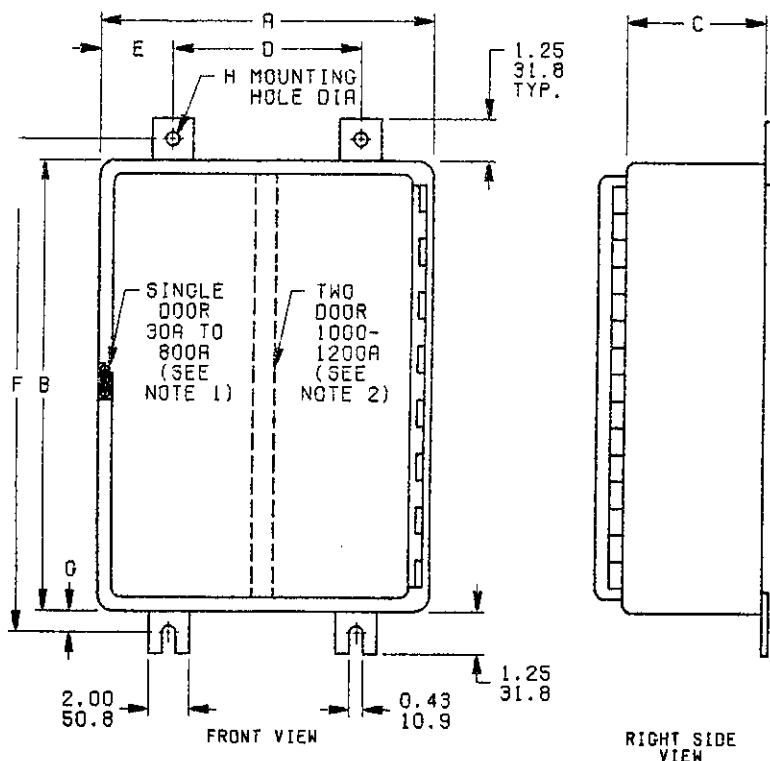

FIGURE 3  
NOTES

(FIGURE 3 ONLY)

NEMA TYPE 3R

NEMA TYPE 4

NEMA TYPE 12

1. SINGLE DOOR HINGED ON RIGHT SIDE WITH PADLOCK HASP. PLATED DOOR CLAMPS ON THREE (3) SIDES FOR NEMA TYPE 3R & 4, AND ONE (1) SIDE FOR NEMA TYPE 12. (30A TO 800A)
2. TWO DOOR NEMA TYPE 3R & 4 ENCLOSURES HAVE REMOVABLE CENTER POST INSTALLED BETWEEN DOORS WITH DOOR CLAMPS ON BOTH SIDES OF CENTER POST. TWO DOOR NEMA TYPE 12 ENCLOSURES HAVE 3-POINT LATCHING WITH KEYLOCKING HANDLE. (1000-1200 A)
3. FULL WIRING GUTTERS PROVIDED TOP AND BOTTOM. NO KNOCKOUTS PROVIDED

### GENERAL NOTES

(FIGURES 1, 2, & 3)

1. ENCLOSURES CONSTRUCTED IN ACCORDANCE WITH UL STANDARD 508 (ANSI C33.76-1971) AS REFERENCED IN UL STANDARD 1008.
2. STANDARD FINISH-LIGHT GREY ANSI #61.
3. WIDTH, HEIGHT, AND DEPTH DIMENSIONS ON FIG. 1 & 2 ARE INSIDE DIMENSIONS. WIDTH, HEIGHT, AND DEPTH DIMENSIONS ON FIG 3 ARE OUTSIDE DIMENSIONS.
4. THE TRANSFER SWITCH UNIT IS MOUNTED ON THE INSIDE BACK SURFACE AND THE ACCESSORY CONTROL PANEL MOUNTED ON THE INSIDE DOOR SURFACE. BOTH UNITS ARE TERMINATED BY A QUICK DISCONNECT PLUG LOCATED ON THE INSIDE OF THE DOOR.
5. USE OPERATOR'S MANUAL 1D4800 FOR ACCESSORY GROUPS 8 & 9, OR 1D4900 FOR ACCESSORY GROUPS 1 & 4. OPERATOR'S MANUAL IS FURNISHED WITH EACH AUTOMATIC TRANSFER SWITCH. REFER TO THIS PUBLICATION PRIOR TO INSTALLATION AND OPERATION OF THE SWITCH.

NEMA TYPE 3R, 4, AND 12 ENCLOSURES FOR ASCO AUTOMATIC TRANSFER SWITCHES WITHOUT ACC. 28 OVERLAPPING NEUTRAL TRANSFER CONTACT							
AMP SIZE	FIG NO	DIMENSIONS					
		A	B	C	D	E	F
30 TO 150	3	17.50	32.50	11.62	11.50	3.00	33.75
		444.5	825.5	295.1	292.1	76.2	857.3
18.00		48.00	13.00	12.00	3.00	49.25	
457.2		1219.2	330.2	304.8	76.2	1251.0	
24.00		63.00	17.50	18.00	3.00	64.25	
609.6		1600.2	444.5	457.2	76.2	1632.0	
36.00	79.00	16.00	30.00	3.00	80.25		
914.4	2006.6	406.4	762.0	76.2	2038.4		
1600 TO 2000		CONSULT FACTORY					
3000 TO 4000		CONSULT FACTORY					
30 TO 150	3	0.62	0.43				
		15.7	10.9				
0.62		0.43					
15.7		10.9					
0.62		0.43					
15.7		10.9					
1600 TO 2000		CONSULT FACTORY					
3000 TO 4000		CONSULT FACTORY					

NEMA TYPE 3R, 4, AND 12 ENCLOSURES FOR ASCO AUTOMATIC TRANSFER SWITCHES WITH ACC. 28 OVERLAPPING NEUTRAL TRANSFER CONTACT							
AMP SIZE	FIG NO	DIMENSIONS					
		A	B	C	D	E	F
30 TO 150	3	17.50	32.50	11.62	11.50	3.00	33.75
		444.5	825.5	295.1	292.1	76.2	857.3
18.00		48.00	13.00	12.00	3.00	49.25	
457.2		1219.2	330.2	304.8	76.2	1251.0	
30.00		63.00	17.50	24.00	3.00	64.25	
762.0		1600.2	444.5	609.6	76.2	1632.0	
44.00	79.00	16.00	38.00	3.00	80.25		
1117.6	2006.6	406.4	965.2	76.2	2038.4		
1600 TO 2000		CONSULT FACTORY					
3000 TO 4000		CONSULT FACTORY					
30 TO 150	3	0.62	0.43				
		15.7	10.9				
0.62		0.43					
15.7		10.9					
0.62		0.43					
15.7		10.9					
1600 TO 2000		CONSULT FACTORY					
3000 TO 4000		CONSULT FACTORY					

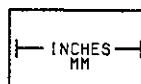

CATALOG NO. \_\_\_\_\_  
CERTIFIED  
TO **ASVA**® S. O. \_\_\_\_\_  
DATE \_\_\_\_\_ BY \_\_\_\_\_

COMPUTER GENERATED DRAWING		
<b>Automatic Switch Co.</b>		
FLORHAM PARK, NEW JERSEY, 07932 PRINTED IN U.S.A.		
BY	DATE	PROPERTY OF AUTOMATIC SWITCH CO.
DRAWN	JTT 3/83	USE PERMITTED FOR OUR WORK ONLY.
CHECKED	NS 3/83	ALL RIGHTS OF DESIGN OR INVENTION
DFTG APVL	FM 3/83	ARE RESERVED.
ENGR APVL	PDG 3/83	AL <input type="checkbox"/> RP <input type="checkbox"/>

COMPOSITE ENCLOSURE OUTLINE AND  
MOUNTING DIAGRAM FOR 2 OR 3 POLE  
30 THROUGH 4000 AMPERES  
**ASVA**® 940 AUTOMATIC TRANSFER SWITCHES  
WITH  
ACCESSORY GROUP 1, 4, 8, & 9  
CONTROL PANELS

ER NO	ITEM	CHGO	CHG	DATE	APVL
87132	SEE ER	G		11/84	FM
84120	SEE ER	F		4/84	PDG
82550	SEE ER	E		11/83	PDG
81511	SEE ER	D		9/83	PDG
89566	SEE ER	J		6/85	XXX
88972	SEE ER	H		5/85	FM
<b>JS345-543</b>					
CHG	LTR	J			



# AUTHORIZED ASCO SERVICE CENTERS

Authorized ASCO Service Centers have personnel who have been trained at the ASCO home office in the preventive maintenance, adjustment, and repair of ASCO automatic transfer switches, RC lighting contactors, engine and generator

controls, SYNCHROPOWER® systems, and other ASCO electromagnetic/solid-state electronic controls.

When you need that kind of assistance on any ASCO controls, contact the Authorized ASCO Service Center nearest you from the list below.

## CALIFORNIA

Electro-Test, Inc.  
5370 Hunter Ave.  
Anaheim, CA 92807  
1-714-779-8900

Electro-Test, Inc.  
9373 Activity Rd. Unit D  
San Diego, CA 92126  
1-619-695-9551

Electro-Test, Inc.  
P.O. Box 159  
3470 Fostoria Way  
San Ramon, CA 94583  
1-415-866-8566

## COLORADO

Electro-Test, Inc.  
7100 Broadway Building (1-0)  
Denver, CO 80221  
1-303-427-8809

## CONNECTICUT

Northeast Electrical Testing  
48 N. Plains Industrial Road  
Wallingford, CT 06492  
1-203-237-8446

## FLORIDA

AMT  
2400 N.W. 39th Avenue  
Miami, FL 33142  
1-305-871-4094

Tampa Armature Works  
440 S. 78th Street  
Tampa, FL 33619  
1-813-621-5661

## GEORGIA

Cleveland Electric Co.  
P.O. Box 44088  
3795 Wendell Drive, S.W.  
Atlanta, GA 30336  
1-404-696-4550

## ILLINOIS

Oakley Services Inc.  
No. Waterworks Road  
P.O. Box 95  
Okawville, IL 62271  
1-618-243-5348

Electron Systems, Inc.  
402 Elm Street  
Deerfield, IL 60015  
1-312-945-7759

## INDIANA

High Voltage Maintenance  
P.O. Box 19292  
1416 Sadlier Circle  
Indianapolis, IN 46219  
1-317-356-6411

## KENTUCKY

High Voltage Maintenance  
7045 Production Ct.  
Florence, KY 41042  
1-606-342-7710

## MARYLAND

MET Electrical Testing Co., Inc.  
916 West Patapsco Avenue  
Baltimore, MD 21230  
1-301-354-2200

## MASSACHUSETTS

Electrical Testing &  
Maintenance Co.  
142 Centre Street  
Holbrook, MA 02343  
1-617-767-4305

## MICHIGAN

Northern Electrical Testing Inc.  
1987 Larchwood  
Troy, MI 48083-2228  
1-313-689-8980

## MINNESOTA

Process Measurement Co.  
5735 Lindsay Street  
Minneapolis, MN 55422  
1-612-544-4035

## MISSISSIPPI

Control Systems Inc.  
P.O. Box 4852  
909 Quinn Street  
Jackson, MS 39216  
1-601-355-8594

## MISSOURI

A/C Control Manufacturing Co.  
1400 Spruce  
Kansas City, MO 64127  
1-816-231-6400

## NEBRASKA

Process Measurement Co.  
4865 G Street  
Omaha, NB 68117  
1-402-734-2434

## NEW JERSEY

Power Equipment Co.  
P.O. Box 4108  
Maple Avenue  
Mt. Holly, NJ 08060-4108  
1-609-267-7373

## NORTH CAROLINA

Beam Electric Co., Inc.  
P.O. Box 6223  
1434 Winnifred Street  
Charlotte, NC 28207  
1-704-333-9094

## OHIO

High Voltage Maintenance  
P.O. Box 14059  
5100 Energy Drive  
Dayton, OH 45414  
1-513-278-0811

High Voltage Maintenance  
7200 Industrial Park Blvd.  
Mentor, OH 44060  
1-216-951-2706

## OREGON

Electro-Test, Inc.  
P.O. Box 22073  
4120 SE International Way  
Suite A 104  
Milwaukie, OR 97222  
1-503-653-6781

## PENNSYLVANIA

MET Electrical Testing Co., Inc.  
105 Pine Street  
Imperial, PA 15126  
1-412-695-3451

## TENNESSEE

SECO Power System Inc.  
358 Walnut Street  
Memphis, TN 38126  
1-901-525-5900

Nixon Detroit Diesel  
P.O. Box 100930  
200 Crutchfield Ave.  
Nashville, TN 37210  
1-615-244-0650

## TEXAS

SHERMCO Industries, Inc.  
2815 Congressman Lane  
Dallas, TX 75220  
1-214-358-4271

Sabre Electric Company  
P.O. Box 79292 (77279)  
10690 Shadow Wood  
Suite 109  
Houston TX 77043  
1-713-984-2761

## VIRGINIA

Mid-Atlantic Power  
Specialists, Inc.  
904 Alabama Drive  
Herndon, VA 22070  
1-703-471-9773

## WASHINGTON

Electro-Test, Inc.  
1517-130th Avenue NE  
Bellevue, WA 98005  
1-206-455-5367

## WISCONSIN

Arthur G. Dietrich Co., Inc.  
1930 East Norse Avenue  
Cudahy, WI 53110-2851  
1-414-747-0200

High Voltage Maintenance  
16285 W. Lincoln Avenue  
New Berlin, WI 53151  
1-414-784-3660

## PUERTO RICO

Phasor Engineering, Inc.  
P.O. Box 9012  
Ponce, PR 00732  
1-809-844-9366



This network of ASCO Service Centers throughout the United States assures prompt, reliable service on ASCO controls by factory trained personnel.

Form ASI 3253  
Rev. 586