



INSTRUCTIONS

GEI-25302C
SUPERSEDES GEI-25302B

CLOSING RELAYS - HEAVY DUTY

Types

**HKA29EM
HKA29FM
HKA29HM**

POWER SYSTEMS MANAGEMENT DEPARTMENT

GENERAL  ELECTRIC

PHILADELPHIA, PA.

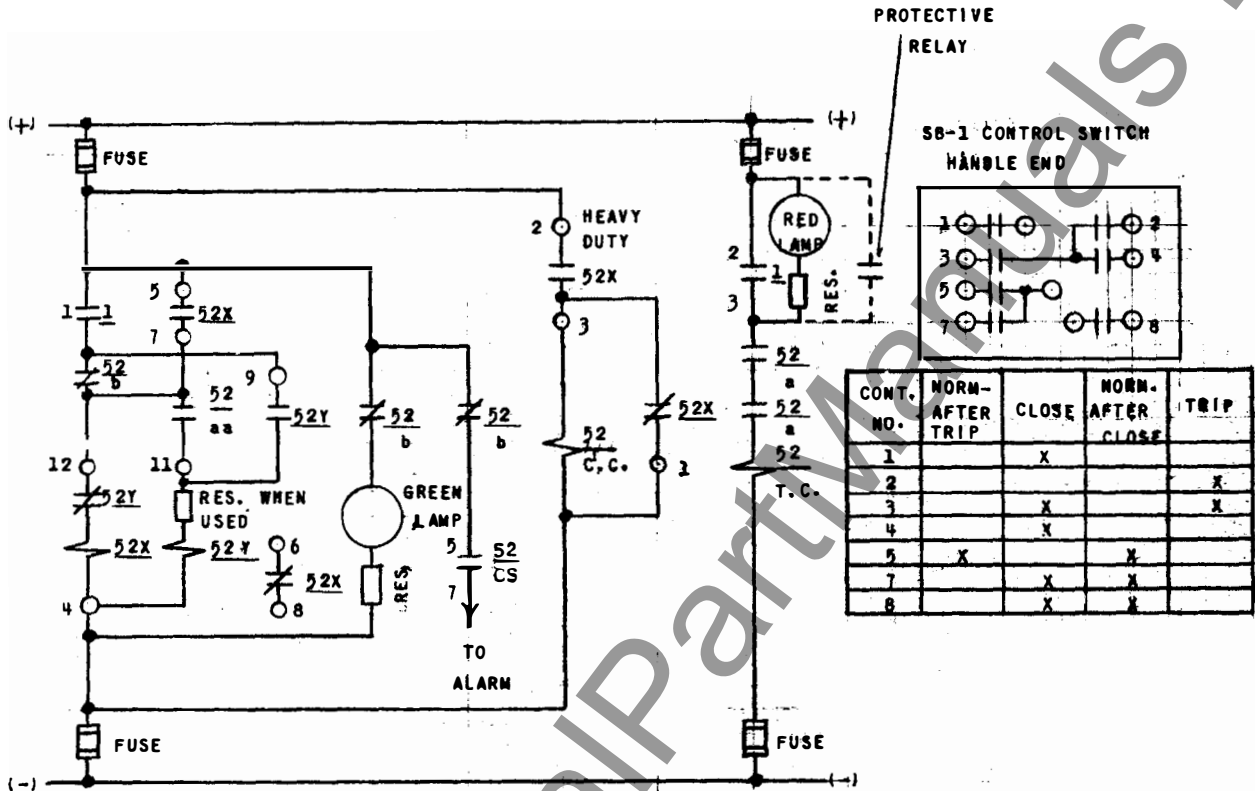

CONT. NO.	NORM-AFTER TRIP	CLOSE	NORM-AFTER CLOSE	TRIP
1		X		
2				X
3		X		X
4		X		
5	X		X	
7		X	X	
8		X	X	

DEVICE	DESCRIPTION
1	TYPE SB-1 CONTROL SW.
52	CIRCUIT BREAKER
52X	UPPER UNIT
52Y	LOWER UNIT
	} CLOSING RELAY TYPE HKA29
a	AUX. SW. CLOSED WHEN BKR. IS CLOSED.
aa	AUX. SW. CLOSED WHEN BKR. CLOSING MECH. IS OPERATED
b	AUX. SW. OPEN WHEN BKR. IS CLOSED
CC	CLOSING COIL OF BKR.
TC	TRIP COIL OF BKR.

Fig. 1 Typical Elementary Diagram For HKA Relays

Fig. 1 (K-6400672)

CLOSING RELAYS - HEAVY DUTY TYPE HKA29

INTRODUCTION

APPLICATION

The Type HKA relays covered by these instructions are used mainly for closing electrically-operated air or oil circuit breakers when the current required for the operation of the closing mechanism exceeds the rating of the control switch in use. They are used instead of the moderate duty line of Type HKA relays when the currents being interrupted are highly inductive. A typical application diagram of these relays is shown in Fig. 1.

RATINGS

These relays are available in ratings of 125, 220, and 250 volts d-c.

The coils of the upper units of these relays are intermittently rated for 30 seconds at the voltage indicated on the nameplate. The coil of the lower unit is continuously rated at the voltage indicated on the nameplate.

CONTACT RATING

Because of the variation in the inductance of the closing solenoids of various circuit breakers, and hence in the stored energy in the solenoid, a contact interrupting rating in terms of current does not represent a true picture of the contact capacity. Therefore, for the relays covered by these instructions the main contact rating is given in terms of an "energy index" which is approximately proportional to $I^2 N^2 D^2$ where:

- N = number of turns in solenoid.
- I = exciting current - E/R value or cutoff value.
- D = diameter of plunger in inches.

Using the product of $I^2 N^2 D^2$ as an index of severity of the interrupting duty, these relays can be applied where the energy index does not exceed 114×10^9 at the cutoff current value and 455×10^9 at the E/R value.

The interlock contacts of the upper unit will close 30 amperes for voltages not exceeding 250 volts and will carry 12 amperes continuously or 30 amperes for one minute. The interrupting ratings of non-inductive circuits for the various voltages are as follows:

Volts Amps.	D-C				A-C	
	24	48	125	250	220	260
	12	6	3	1	15	15

The lower unit contacts will interrupt the upper unit coil current at 110 per cent of its nameplate rated voltage and will carry continuously the coil current of its own operating coil at 110 per cent of its nameplate rated voltage.

BURDENS

The upper unit coil has a burden of approximately 55 watts at its intermittent d-c rated voltage.

The approximate total circuit burden for lower units with series resistors included is shown below:

Voltage Rating	Burden
125 DC	9 Watts
220 DC	15 Watts
250 DC	16 Watts

RECEIVING, HANDLING AND STORAGE

These relays, when not included as a part of a control panel will be shipped in cartons designed to protect them against damage. Immediately upon receipt of a relay, examine it for any damage sustained in transit. If injury or damage resulting from rough handling is evident, file a damage claim at once with the transportation company and promptly notify the nearest General Electric Apparatus Sales Office.

Reasonable care should be exercised in un-

packing the relay in order that none of the parts are injured or the adjustments disturbed.

If the relays are not to be installed immediately, they should be stored in their original cartons in a place that is free from moisture, dust and metallic chips. Foreign matter collected on the outside of the case may find its way inside when the cover is removed and cause trouble in the operation of the relay.

These instructions do not purport to cover all details or variations in equipment nor to provide for every possible contingency to be met in connection with installation, operation or maintenance. Should further information be desired or should particular problems arise which are not covered sufficiently for the purchaser's purposes, the matter should be referred to the General Electric Company.

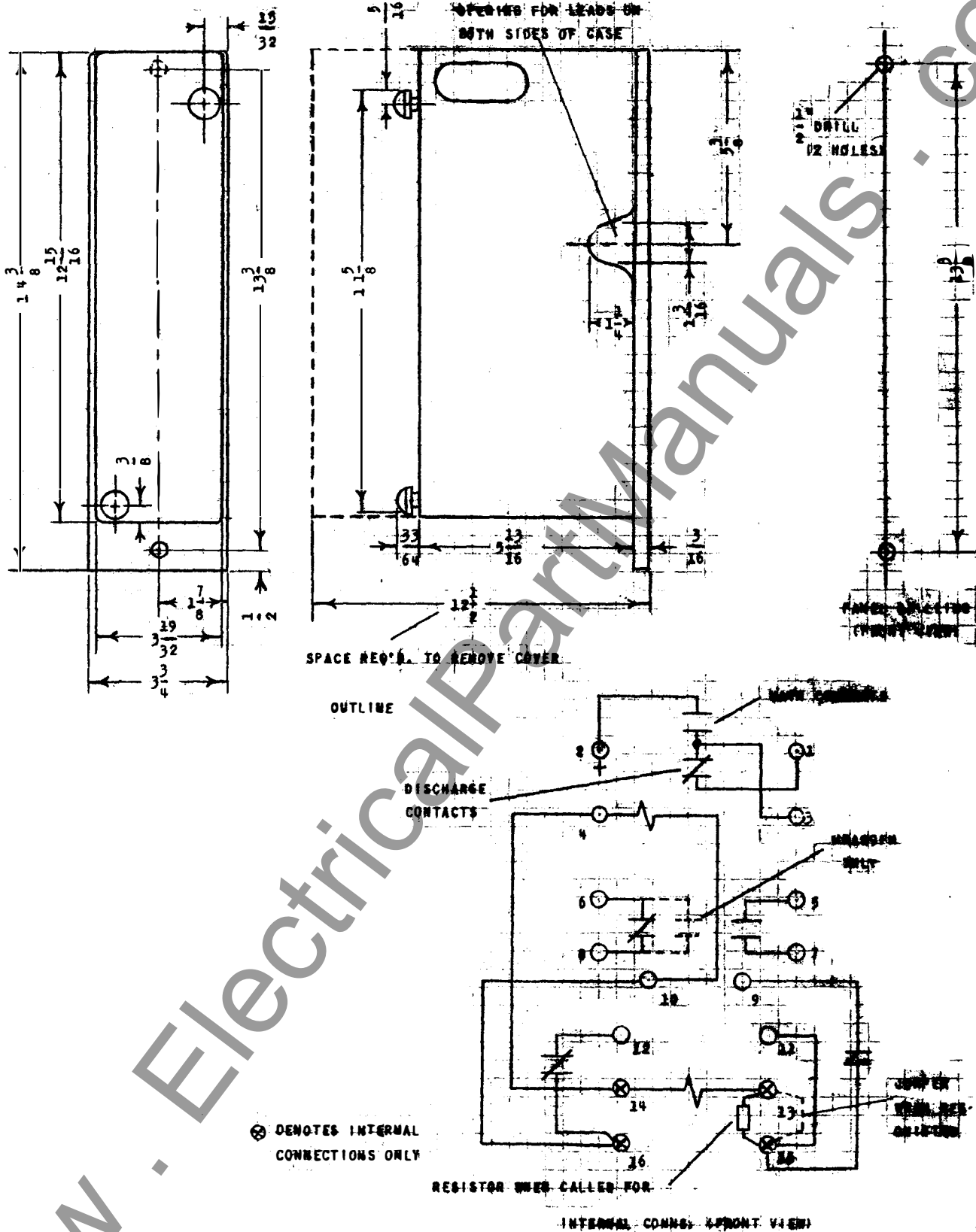

Fig. 2 (K-6400671)

Fig. 2 Outline, Panel Drilling And Internal Connections For Type HKA29EM And HKA29FM Relays

DESCRIPTION

The relays consist of two hinged armature-type relay units mounted on a steel plate. The upper unit, known as the X unit, is the closing unit whose main contact operates the closing mechanism of the breaker. The unit consists of a main heavy duty contact with magnetic blowout, two electrical interlock contacts and one discharge contact.

The moving contact of the main contact is constructed to serve as the moving contact of the discharge contact also. With the armature in the de-energized position this moving contact makes with a bracket-type stationary contact which is secured to the *Textolite base and extends directly over the armature assembly.

The lower unit, known as the Y unit, is a simple hinged armature-type relay having one normally-open and one normally-closed contact. This unit, Type HMA relay, has an internally-mounted resistor in series with its operating coil for all d-c relays rated 125 volts and higher.

The cover, when used, has ventilating cutouts provided for escape of gases generated by the arc interruption. This cover is larger than the one used on light and moderate Type HKA relays.

The relays covered by these instructions are front connected.

The Type HKA29EM relay was described in the preceding paragraphs. This relay has one normally-open and one normally-closed interlock.

The Type HKA29FM relay is similar to the Type HKA29EM relay except that it has two normally-open interlocks.

The Type HKA29HM relay is similar to the Type HKA29EM relay except that the cover is omitted and there is a slight change in the mounting of the relay units and resistor.

INSTALLATION

LOCATION AND MOUNTING

Relays shipped as supply items should be mounted on vertical surface near the circuit breaker where it will not be subjected to excessive vibration or heat from resistors and other sources. When mounting the relay it may be necessary to consider the direction of the stray field produced by the closing coil of the breaker, if the relay is close to it, or else shield the relay from its effects.

The outline and panel drilling dimensions are shown in Figs. 2 and 3.

CONNECTIONS

The internal connection diagrams are also shown in Figs. 2 and 3. Because of the permanent magnet blowout feature on the main unit, the polarities given in the internal connection diagram for the type of relay in question should be strictly observed.

PRINCIPLES OF OPERATION

The X unit of the Type HKA relay picks up instantaneously when energized through the control switch, a normally-closed auxiliary switch of the circuit breaker and the normally-closed contact of the Y unit. The main contact of the X unit energizes the closing solenoid of the circuit breaker. A normally-open interlock on the X unit also closes, setting up the circuit to the Y unit. This circuit is completed by a normally-open auxiliary switch on the breaker (designated as "52 aa") and the Y unit picks up instantaneously sealing itself in. The normally-closed contacts of the Y unit opens the X unit coil circuit causing it to drop out. The X unit main contact opens the solenoid circuit of the circuit breaker closing mechanism, causing an arc to be blown upward between the main contacts. At the

instant the discharge contact makes, the closing solenoid is shorted and the arc goes out. The stored energy in the magnetic field of the closing solenoid is dissipated in the form of I^2R losses in the solenoid instead of attempting to maintain the arc. Because the resistance of the discharge path is low, the time constant (L/R) can be relatively large depending on the inductance of the solenoid. The closing solenoid plunger does not reset until the circulating current decays to the dropout value which can produce a time delay as much as 8 seconds. The effect is the prevention of immediate successive reclosures of the circuit breaker.

The seal-in feature of the Y unit makes the system "pump free".

*Reg. Trade- Mark of General Electric Co.

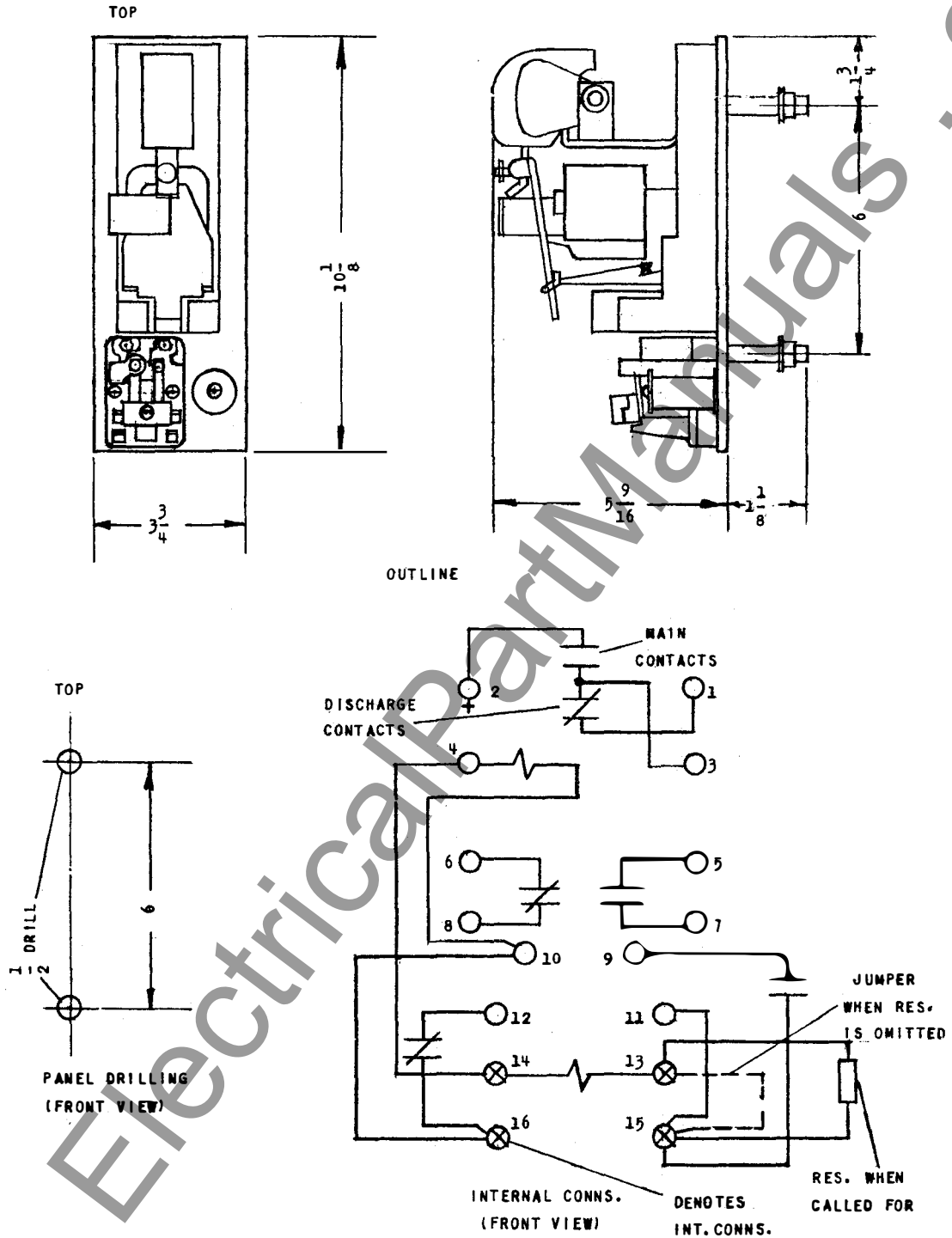

Fig. 3 Outline, Panel Drilling And Internal Connections For Type HKA29HM Relay

MAINTENANCE

INSPECTION AND ADJUSTMENTS

The relays have been adjusted at the factory to operate at less than 60 per cent of rating. Normally it should not be necessary to change the settings of the various contact gaps and wipes, however, if readjustment is necessary the following points should be observed.

The control springs of both the upper and lower units should be adjusted for the maximum tension which will still result in pick-up voltages of less than 60 per cent of the d-c rating.

The wipe of the upper unit main contacts should be 1/8-inch measured at the top of the pole piece while that of the interlocks should be 1/8-inch when measured at the end of the interlock contact support. The main contact gap should be at least 23/64-inch and is not adjustable.

The gap of the "b" contact of the lower unit should be 3/64 to 1/16-inch with the armature closed. This can be set by means of the adjustable back contact screw. There should be approximately 1/32-inch wipe on the "a" contacts; being measured between the upper edge of the armature and the pole piece with the "a" contact just making.

The discharge contact of the upper unit should always have enough wipe to increase the main contact gap approximately 1/8-inch. This can be checked by comparing the gap when the discharge contacts just make and after they have fully wiped in. This wipe is not adjustable. However, the following points should be checked: The upper unit control spring tension should be set at the allowable maximum; the interlocks should not have more than the recommended 1/8-inch wipe; the flexible shunt connected to the movable contact should be free to bend with the armature motion and should not be hindered by any connecting leads that might be used for other internal connections; the armature and moving contact should be free of any mechanical interference.

If it is ever necessary to replace the arc chute, care must be taken to replace the permanent magnet so that the left end of the magnet is the North pole when facing the relay. Make sure that the connection polarities are identical with those indicated on the connection diagram, Fig. 1.

Relay Types HKA29EM and HKA29FM will operate satisfactorily only with the cover having ventilating slots in it. Also, it is important to make sure that the discharge contacts are actually shorting out the solenoid of the breaker.

RENEWAL PARTS

It is recommended that sufficient quantities of renewal parts be carried in stock to enable the prompt replacement of any that are worn, broken, or damaged.

When ordering renewal parts, address the

A periodic check should be made to insure that the relay units are picking up below the limits given under adjustments, and that the various wipes and contact gaps have not been disturbed.

CONTACT CLEANING

For cleaning fine silver contacts, a flexible burnishing tool should be used. This consists of a flexible strip of metal with an etched roughened surface, resembling in effect a superfine file. The polishing action is so delicate that no scratches are left, yet corroded material will be removed rapidly and thoroughly. The flexibility of the tool insures the cleaning of the actual points of contact. Sometimes an ordinary file cannot reach the actual points of contact because of some obstruction from some other part of the relay.

Fine silver contacts should not be cleaned with knives, files, or abrasive paper or cloth. Knives or files may leave scratches which increase arcing and deterioration of the contacts. Abrasive paper or cloth may leave minute particles of insulating abrasive material in the contacts and thus prevent closing.

The burnishing tool described above can be obtained from the factory.

REPLACEMENT OF MAIN CONTACTS

If it is necessary to replace the main stationary contact of the upper or X unit it will be necessary to remove the arc chute assembly. All the parts of this assembly are held together between the U-shaped bracket by a long screw extending through a hole in the blowout magnet. If this screw is removed the entire assembly can be lifted out. The main stationary contact can then be easily replaced and the replacement securely tightened.

The reassembly procedure can be simplified by fitting the pole pieces to the sides of the arc chutes, placing the permanent magnet between the pole pieces, and then transferring the entire assembly into position on the U-shaped bracket. If an arc shield is used it should be replaced in its correct position on the sides of the bracket and between the arc chute and coil. The screw should then be inserted through the holes in the bracket, pole pieces, and magnet, and secured with a lockwasher and nut. Care must be taken when reassembling the magnet that the north pole of the magnet, the end which is numbered, is on the left side of the relay when viewed from the front; otherwise the reversed polarity will cause the arc to blow downwards. The movable contact finger should not hit the sides of the arc chute in any position of the armature.

nearest Sales Office of the General Electric Company, specify quantity required, name of part wanted, and give complete nameplate data, including serial number. If possible, give the General Electric Company requisition number on which the relay was furnished.

GENERAL ELECTRIC INSTALLATION AND SERVICE ENGINEERING OFFICES

FIELD SERVICE OFFICE CODE KEY

- * Mechanical & Nuclear Service
- † Electrical & Electronic Service
- ‡ Marine Service
- X Transportation

FOR YOUR LASTING SATISFACTION... with the performance and availability of your General Electric equipment, GE provides this nationwide network of field service offices, serving utility, industrial, transportation and marine users. Qualified field engineers provide installation, start-up, employee training, engineering maintenance and other services, throughout the productive life of the equipment. For full information, call your nearest Installation & Service Engineering office.

ALABAMA
 † Birmingham 35205 2151 Highland Ave.
 * † † Mobile 36609 1111 S. Beltline Highway

ALASKA
 † Anchorage 99501 115 Whitney Rd.

ARIZONA
 * † Phoenix 85012 3550 N. Central Ave.
 † Tucson 85716 151 S. Tucson Blvd.

ARKANSAS
 † North Little Rock 72119 120 Main St.

CALIFORNIA
 * † † Los Angeles 90054 212 N. Vignes St.
 † Palo Alto 94303 960 San Antonio Rd.
 † Sacramento 95808 2407 J St.
 † San Diego 92103 2560 First Ave.
 * † San Francisco 94119 55 Hawthorne St.
 † Vernon 90058 3035 E. 46th St.

COLORADO
 * † Denver 80206 201 University Blvd.

CONNECTICUT
 * † Meriden 06450 1 Prestige Dr.

FLORIDA
 † † Jacksonville 32203 4040 Woodcock Dr.
 † Miami 33134 4100 W. Flagler St.
 * † † Tampa 33609 2106 S. Lois Ave.

GEORGIA
 * † † Atlanta 30309 1860 Peachtree Rd., NW
 † Savannah 31405 5002 Paulsen St.

HAWAII
 * † † Honolulu 96813 440 Coral St.

ILLINOIS
 * † † X Chicago 60680 840 S. Canal St.

INDIANA
 † Evansville 47705 2709 Washington Ave.
 † Fort Wayne 46807 3606 S. Calhoun St.
 * † Indianapolis 46207 3750 N. Meridian St.

IOWA
 † Davenport 52805
 . . . P. O. Box 630, 1039 State St., Bettendorf

KENTUCKY
 † Louisville 40218 2300 Meadow Dr.

LOUISIANA
 † Baton Rouge 70806 8312 Florida Blvd.
 * † † New Orleans 70125 4747 Earhart Blvd.
 * † † Shreveport 71104 2620 Centenary Blvd.
 † Monroe 71201 1028 North 6th St.

MARYLAND
 * † † Baltimore 21201 1 N. Charles St.

MASSACHUSETTS
 * † † Wellesley 02181 1 Washington St.

MICHIGAN
 * † † Detroit 48202 700 Antoinette St.
 † Jackson 49201 210 W. Franklin St.
 † Saginaw 48607
 1008 Second National Bank Bldg.

MINNESOTA
 † † Duluth 55802 300 W. Superior St.
 * † † Minneapolis 55416 1500 Lilac Drive So.

MISSOURI
 * † † Kansas City 64199 911 Main St.
 * † † St. Louis 63101 1015 Locust St.

MONTANA
 † Butte 59701 103 N. Wyoming St.

NEBRASKA
 * † Omaha 68102 409 S. 17th St.

NEW JERSEY
 * † Millburn 07041 25 E. Willow St.

NEW YORK
 † † Albany 12205 15 Computer Drive, West
 * † † Buffalo 14205 625 Delaware Ave.
 * † † X New York 10022 641 Lexington Ave.
 † Rochester 14604 89 East Ave.
 * † Syracuse 13206 3532 James St.

NORTH CAROLINA
 * † † Charlotte 28207 141 Providence Rd.
 † Wilmington
 † Reigelwood 28456 P. O. Box 186

OHIO
 * † Cincinnati 45206 2621 Victory Pkwy.
 * † Cleveland 44104 1000 Lakeside Ave.
 † Columbus 43229 1110 Morse Rd.
 † † Toledo 43606 3125 Douglas Rd.
 † Youngstown 44507 272 Indianola Ave.

OKLAHOMA
 * † Oklahoma City 73106 2000 Classen Blvd.
 † Tulsa 74105 P. O. Box 7646, Southside Sta.

OREGON
 * † Eugene 97401 1170 Pearl St.
 † † Portland 97210 2929 NW 29th Ave.

PENNSYLVANIA
 * † Allentown 18102 1444 Hamilton St.
 * † † Philadelphia 19102 3 Penn Center Plaza
 * † Pittsburgh 15222 300 6th Avenue Bldg.

SOUTH CAROLINA
 † † Columbia 29204 2700 Middleburg Dr.
 † Greenville 29607 41 No. Pleasantburg Dr.

TENNESSEE
 * † Chattanooga 37411
 5800 Bldg, Eastgate Center
 † Memphis 38130 3385 Airways Blvd.

TEXAS
 * † † Amarillo 79101 303 Polk St.
 * † † Beaumont 77704 1385 Calder Ave.
 * † † Corpus Christi 78401 205 N. Chaparral St.
 † Dallas 75222 8101 Stemmons Freeway
 † El Paso 79945 215 N. Stanton
 † Fort Worth 76102 408 W. Seventh St.
 * † † Houston 77027 4219 Richmond Ave.
 † San Antonio 78204 434 S. Main St.

UTAH
 † Salt Lake City 84111 431 S. Third East St.

VIRGINIA
 * † Newport News 23601 311 Main St.
 † † Richmond 23230 1508 Willow Lawn Dr.
 † Roanoke 24015 2018 Colonial Ave.

WASHINGTON
 * † † Seattle 98188
 112 Andover Park East, Tukwila
 † Spokane 99202 E. 1805 Trent Ave.

WEST VIRGINIA
 * † Charleston 25328 306 MacCorkle Ave., SE

WISCONSIN
 * † Appleton 54911 3003 West College Dr.
 † † Milwaukee 53202 615 E. Michigan St.

GENERAL ELECTRIC SERVICE SHOPS

WHEN YOU NEED SERVICE... These GE Service Shops will repair, recondition, and rebuild your electric apparatus. The facilities are available day and night, seven days a week, for work in the shops or on your premises.

Latest factory methods and genuine GE renewal parts are used to maintain performance of your equipment. For full information about these services, contact your nearest service shop or sales office.

ALABAMA
 • • Birmingham 35211 1500 Mims Ave., S.W.
 • • Mobile 36609 721 Lakeside Dr.

ARIZONA
 • • (Phoenix) Glendale 85019 4911 W. Colter St.
 • • Phoenix 85019 3840 W. Clarendon St.
 • • Tucson 85713 2942 So. Palo Verde Ave.

CALIFORNIA
 • • Los Angeles 90301 6900 Stanford Ave.
 • • (Los Angeles) Anaheim 92805
 • • 3601 E. LaPalma Ave.
 • • (Los Angeles) Inglewood 90301
 • • 228 W. Florence Ave.
 • • Sacramento 95814 99 North 17th St.
 • • (San Francisco) Oakland 94608
 • • 1650 34th St.

COLORADO
 • • Denver 80205 3355 Larimer St.

CONNECTICUT
 • • (Southington) Plantsville 06479
 • • 370 Atwater St.

FLORIDA
 • • Jacksonville 32203 2020 W. Beaver St.
 • • (Miami) Hialeah 33010 1062 East 28th St.
 • • Tampa 33601 19th & Grant Sts.

GEORGIA
 • • (Atlanta) Chamblee 30341
 • • 5035 Peachtree Industrial Blvd.
 • • Atlanta 2379 John Glenn Dr.

ILLINOIS
 • • Chicago 80638 6045 S. Nottingham Ave.

INDIANA
 • • Evansville 47711 401 N. Congress Ave.
 • • Ft. Wayne 46803 1731 Edsall Ave.
 • • Hammond 46320 1138 164th Place
 • • Indianapolis 46222 1740 W. Vermont St.

IOWA
 • • (Davenport) Bettendorf 52722 1025 State St.

KENTUCKY
 • • Louisville 40209 3900 Crittenden Drive

LOUISIANA
 • • Baton Rouge 70814 10955 North Dual St.
 • • New Orleans 70114 1115 DeArmas St.

MARYLAND
 • • Baltimore 21230 920 E. Fort Ave.

MASSACHUSETTS
 • • • • (Boston) Medford 02155
 • • 3960 Mystic Valley Pkwy.

MICHIGAN
 • • • • (Detroit) Riverview 18075 Krause Ave.
 • • Flint 48505 1506 E. Carpenter Rd.

MINNESOTA
 • • Duluth 55807 50th Ave. W & St. Louis Bay
 • • Minneapolis 55430 2025 49th Ave., N.

MISSOURI
 • • Kansas City 64120 3525 Gardner Ave.
 • • St. Louis 63110 1115 East Rd.

NEW JERSEY
 • • New Brunswick 08902 3 Lawrence St.

NEW MEXICO
 • • Albuquerque 87109 4420 McLeod Rd. NE

NEW YORK
 • • Albany 12205 1097 Central Ave.
 • • (Buffalo) Tonawanda 14150 175 Millens Rd.
 • • (Long Island) Old Bethpage 11804
 • • 183 Bethpage-Sweet Hollow Rd.
 • • (New York City) North Bergen, N. J. 07012
 • • 6001 Tonelle Ave.
 • • (New York City) Clifton, N. J. 07012
 • • 9 Brighton Rd.
 • • Schenectady 12305 1 River Rd.
 • • Syracuse 13208 1015 E. Hiawatha Blvd.

NORTH CAROLINA
 • • Charlotte 28208 2328 Thrift Rd.

OHIO
 • • Akron (Canton) 44720
 • • 7900 Whipple Ave. N. W.
 • • Cincinnati 45202 444 West 3rd St.
 • • Cleveland 44125 4477 East 49th St.
 • • Columbus 43229 6680 Huntley Rd.
 • • Toledo 43605 405 Dearborn Ave.
 • • Youngstown 44507 272 E. Indianola Ave.

OKLAHOMA
 • • Tulsa 74145 5220 S. 100th East Ave.

OREGON
 • • Eugene 97402 570 Wilson St.
 • • Portland 97210 2727 NW 29th Ave.

PENNSYLVANIA
 • • Allentown 18103 668 E. Highland St.
 • • (Delaware Valley) Cherry Hill, N. J., 08034
 • • 1790 E. Mariton Pike
 • • Johnstown 15802 841 Oak St.
 • • Philadelphia 19124 1040 East Erie Ave.
 • • (Pittsburgh) West Mifflin 15122
 • • 4930 Buttermilk Hollow Rd.
 • • York 17403 54 N. Harrison St.

SOUTH CAROLINA
 • • (Charleston) No. Charleston 29401
 • • 2490 Debonair St.

TENNESSEE
 • • Knoxville 37914
 • • 2621 Governor John Sevier Hwy.
 • • Memphis 38107 708 North Main St.

TEXAS
 • • Beaumont 77705 1490 W. Cardinal Dr.
 • • Corpus Christi 78401 115 Waco St.
 • • Dallas 75235 3202 Manor Way
 • • Houston 77036 5534 Harvey Wilson Dr.
 • • Houston 77036 6916 Harwin Dr.
 • • Midland 79701 704 S. Johnston St.

UTAH
 • • Salt Lake City 84110 301 S. 7th West St.

VIRGINIA
 • • Richmond 23224 1403 Ingram Ave.
 • • Roanoke 24013 1004 River Ave., SE

WASHINGTON
 • • Seattle 98134 3422 First Ave., South
 • • Spokane 99211 E. 4323 Mission St.

WEST VIRGINIA
 • • Charleston 25328 306 MacCorkle Ave., SE

WISCONSIN
 • • (Appleton) Menasha 54910 1725 Racine St.
 • • Milwaukee 53207 235 W. Oklahoma Ave.

• Electrical/Mechanical Service Shop * Instrumentation Shop Δ Special Manufacturing Shop