

INSTRUCTIONS

Switchgear

DIRECTIONAL OVERCURRENT RELAYS

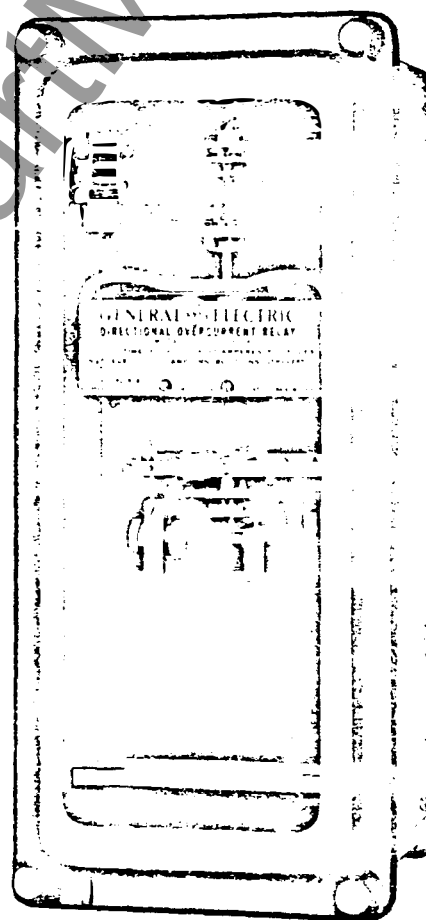

Types

**IBC51A IBC51A IBCP51A
IBC52A IBC52A IBCP52A**

GENERAL  ELECTRIC

WWW

CONTENTS

com

	PAGE
INTRODUCTION	5
OVERCURRENT UNIT	5
DIRECTIONAL UNIT	5
CASE	5
APPLICATION	6
OPERATING CHARACTERISTICS	6
DIRECTIONAL UNIT	8
OVERCURRENT UNIT	8
RATINGS	8
BURDENS	11
RECEIVING, HANDLING AND STORAGE	14
RECEIVING	14
HANDLING	14
STORAGE	14
INSTALLATION	14
LOCATION	14
MOUNTING	14
CONNECTIONS	14
GROUND CONNECTIONS	14
ADJUSTMENTS	15
OVERCURRENT UNIT	15
DIRECTIONAL UNIT	16
OPERATION	17
MAINTENANCE	18
Disk and Bearings - Overcurrent Unit	18
Contacts - Overcurrent Unit	18
Contact Cleaning - Both Units	18
Contacts - Directional Unit	18
Cup and Stator - Directional Unit	18
Clutch Adjustment - Directional Unit	19
Bearings - Directional Unit	19
Torque Adjustment - Directional Unit	19
Periodic Testing	20
RENEWAL PARTS	20
ORDERING INSTRUCTIONS	20

These instructions do not purport to cover all details or variations in equipment nor to provide for every possible contingency to be met in connection with installation, operation or maintenance. Should further information be desired or should particular problems arise which are not covered sufficiently for the purchaser's purposes, the matter should be referred to the General Electric Company.

(8007268)(Cover)

www.ElectricalPartManuals.com

GEH-1267C Type IBC Directional Overcurrent Relays

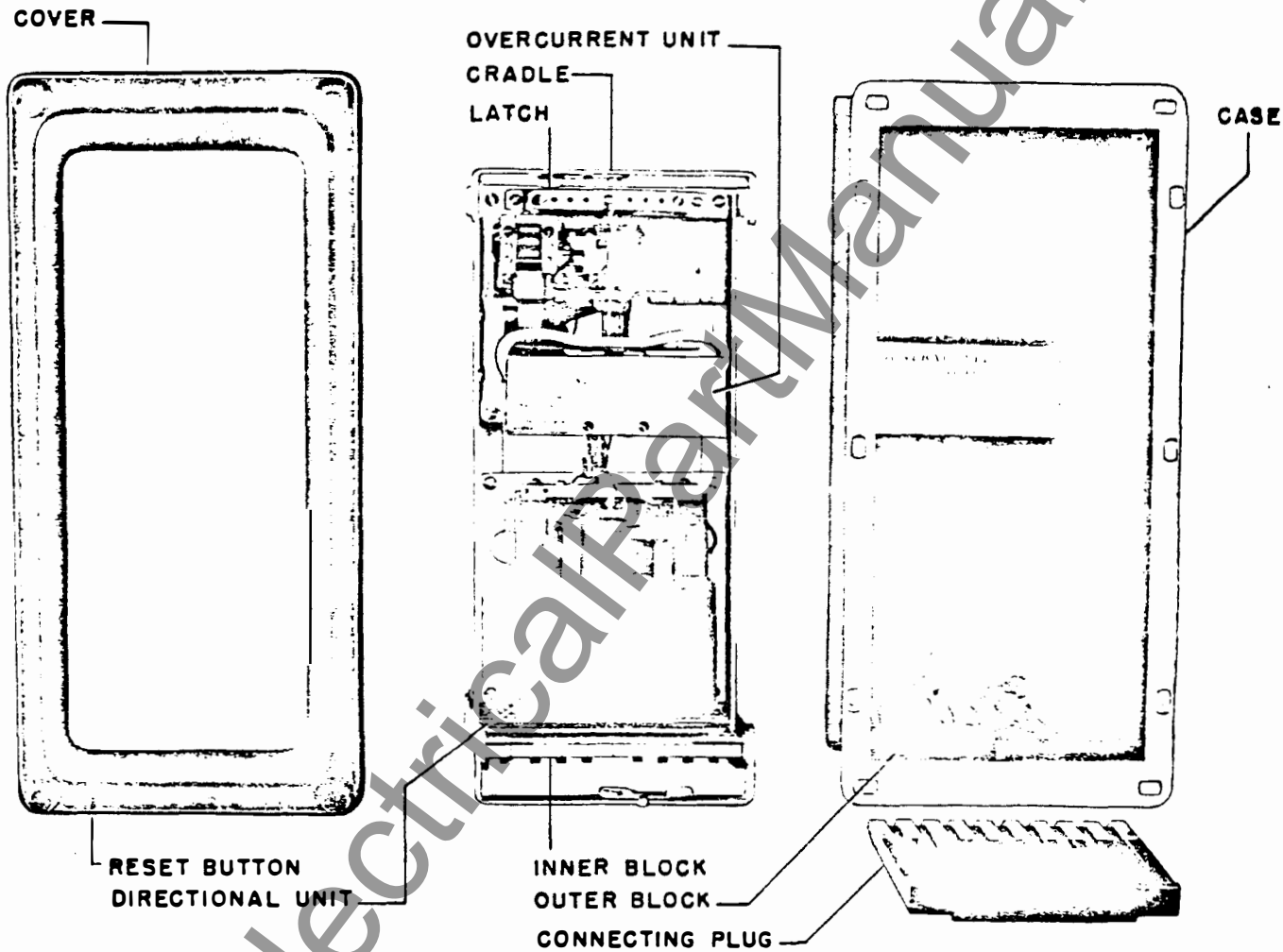

Fig. 1 The Type IBC51A Relay Disassembled

(8007267)

DIRECTIONAL OVERCURRENT RELAYS TYPE IBC

INTRODUCTION

Former designation - IBC51A - IBC52A - IBC53A - IBC54A - IBC55A - IBC56A. New designation IBC51A - IBC52A - IBCP51A - IBCP52A - IBCC51A - IBCC52A.

The type IBC relays comprise a group of relays that are employed primarily for protection of feeders and transmission lines in applications where single-phase relays, instead of polyphase power directional relays, are desired or required.

These relays consist of an induction-disk overcurrent unit and an induction cup unit both mounted in a two-unit, single-end, case. The induction-disk unit provides the time delay characteristics of the relay.

The various relays in this group are identified by model numbers. The relays differ in the number of contacts, angle of maximum torque, and the type of polarization (potential polarization or current polarization).

OVERCURRENT UNIT

The overcurrent unit of the type IBC relay with inverse time characteristics is practically the standard type IAC relay except that it has wound shading coils. The disk is actuated by a current operating coil on a laminated U-shaped magnet. The disk shaft carries the moving contact which completes the alarm or trip circuit when it touches the stationary contact or contacts. The disk shaft is restrained by a spiral spring to give the proper contact closing current and its motion is retarded by permanent magnets acting on the disk to give the correct time delay.

The U-shaped magnet is provided with wound shading coils connected to an internally mounted step-up transformer as shown by Figs. 11 to 16 inclusive. The shading coils act to produce a split-phase field, which in turn develops torque on the operating disk. The secondary of the transformer is connected to the directional unit contacts which control the operation of the overcurrent unit. When the transformer secondary is short-circuited the overcurrent unit is operative; when it is open-circuited the overcurrent unit resets and will not close its contacts even though the current exceeds 20 times pickup value. The purpose of the transformer is to raise the voltage across the directional unit contacts to a minimum of 24 volts so as to assure effective action of the contacts. The overcurrent unit is thus rendered inoperative except when power flows in the proper direction for tripping. This method of obtaining directional discrimination is designated as "Directional Control".

There is a seal-in element mounted on the front to the left of the shaft. This element has its coil

in series and its contacts in parallel with the main contacts such that when the main contacts close the seal-in element picks up and seals in. When the seal-in element picks up, it raises a target into view which latches up and remains exposed until released by pressing a button beneath the lower-left corner of the cover.

DIRECTIONAL UNIT

This unit is an induction cylinder device for alternating-current circuits. The principle by which torque is developed in these induction-cylinder relays is the same as that employed in an induction disk relay with a watt-hour meter element, though in arrangement of parts they are more like split-phase induction motors.

The stator has eight laminated magnetic poles projecting inward and arranged symmetrically around a central magnetic core. The poles are fitted with current and potential coils (on the potential polarized relay); four potential coils which are internally connected forming a single circuit as well as four current coils similarly connected. In the annular air gap between the poles and central core is the cylindrical part of the cup-like aluminum rotor, which turns freely in the air gap. The central core is fixed to the stator frame; the rotor alone turns.

The current polarized unit differs from the above unit by using current coils instead of the potential coils.

This construction provides higher torque and lower rotor inertia than the induction disk construction, making these relays faster and more sensitive.

CASE

The case is suitable for either surface or semi-flush panel mounting and an assortment of hardware is provided for either mounting. The cover attaches to the case and also carries the reset mechanism when one is required. Each cover screw has provision for a sealing wire.

The case has studs or screw connections at both ends or at the bottom only for the external connections. The electrical connections between the relay units and the case studs are made through spring backed contact fingers mounted in stationary molded inner and outer blocks between which nests a removable connecting plug which completes the circuits. The outer blocks, attached to the case, have the studs for the external connections, and the inner blocks have the terminals for the internal connections.

GEH-1267C Type IBC Directional Overcurrent Relays

The relay mechanism is mounted in a steel framework called the cradle and is a complete unit with all leads being terminated at the inner block. This cradle is held firmly in the case with a latch at the top and the bottom and by a guide pin at the back of the case. The cases and cradles are so constructed that the relay cannot be inserted in the case upside down. The connecting plug, besides making the electrical connections between the respective blocks of the cradle and case, also locks the latch in place. The cover, which is fastened to the case by thumbscrews, holds the connecting plug in place.

To draw out the relay unit the cover is first removed, and the plug drawn out. Shorting bars are provided in the case to short the current transformer circuits. The latches are then released, and the relay unit can be easily drawn out. To replace the relay unit, the reverse order is followed.

A separate testing plug can be inserted in place of the connecting plug to test the relay in place on the panel either from its own source of current and voltage, or from other sources. Or, the relay unit can be drawn out and replaced by another which has been tested in the laboratory.

APPLICATION

For the protection of a single line, Figs. 2 and 3 illustrate the application of these relays to phase-fault protection.

The quadrature or 90-degree connection of current and potential transformers as shown in Fig. 2 is recommended as providing the most reliable potential for the directional units during usual fault conditions. With this connection, the current (at unity-power-factor load) leads the potential 90 degrees at the relay terminals. The internal resistor shorting-link should be opened by disconnecting it from the top screw to give the 45-degree characteristic. (The link is located on the right-hand post at the top of the cup-type unit.) The directional unit will then have maximum torque when the fault current lags its unity-power-factor position by about 45 degrees.

When used in conjunction with a ground relay which requires that the potential transformer primaries be connected in Y, with secondaries in delta, the quadrature connection cannot be employed. For this application the 60-degree connection, as shown in Fig. 3, is recommended. The current at unity-power-factor load then leads the potential 60 degrees at the relay terminals. The internal resistor should be short-circuited by the link to provide maximum torque of the directional unit when the fault current lags its unity-power-factor position by approximately 40 degrees.

The quadrature and 60-degree connections are

generally used with these relays, because fault currents are usually highly lagging. With these connections the directional unit will have substantially maximum torque under usual fault conditions.

Vector relationships for the two connections are shown in the tabulation on page 8.

The schemes previously described protect against ground faults if the ground current is not limited to a value too small to operate the relay. For cases where this ground current is limited (either by resistance in the system ground or by the system characteristics) to values that will not operate the phase relay, a ground relay should be provided as shown in Figs. 4 to 6. The relays used for ground-fault protection usually have a low current coil with taps which may be rated 0.5-2.0 or 1.5-6 amperes, although the 4-16 ampere rating is also available. Normally no current flows through the ground relay.

Fig. 4 shows the external connections of the type IBC relay for directional overcurrent protection on ground faults with wye-broken-delta (broken delta signifies a complete delta with one corner open) potential transformers. If the potential transformers are connected wye-wye instead of wye-broken-delta, auxiliary wye-broken-delta potential transformers (type YT-1557) should be connected as the potential transformers shown connected in Fig. 5.

OPERATING CHARACTERISTICS

The type IBC51A is a phase relay with single-circuit closing contacts and having an internal resistor to provide maximum torque angles of 20- and 45-degrees leading for 50- or 60-cycle relays, and 30- and 45-degrees leading for 25-cycle relays.

The type IBC52A relay differs from the type IBC51A only in that the contacts are two-circuit closing.

The type IBCP51A is a ground relay, potential polarized with single circuit-closing contacts, and

having an internal capacitor to provide maximum torque in the directional unit at 45-degree lag.

The type IBCP52A relay differs from the type IBCP51A relay only in that the contacts are two-circuit closing.

The type IBCC51A is a ground relay, current polarized, with single-circuit closing contacts; the type IBCC52A relay differs from it by having contacts that are two-circuit closing.

DEVICE FUNCTION NUMBERS FOR ALL EXTERNAL DIAGRAMS

- 52 - Power Circuit Breaker
- 67 - Directional Overcurrent, Relay Type IBC
- 67N - Directional Overcurrent Ground Relay, Type IBC
- a - Auxilliary Contact, Closed when Breaker Closes
- C - Capacitor
- DIR - Directional Element of IBC Relays
- OC - Overcurrent Element of IBC Relays
- SI - Seal-in Element, With Target
- TC - Trip Coil

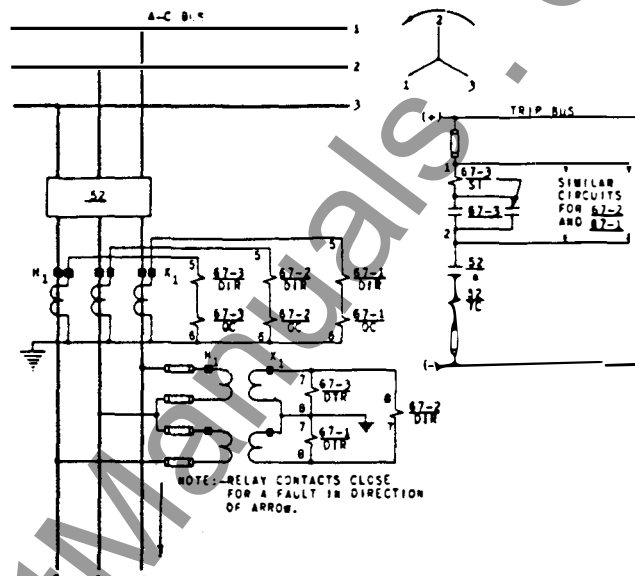

Fig. 2 Quadrature or 90-degree Connection of Three Single-phase Type IBC51A Relays Used for Directional Overcurrent Protection of a Single Line

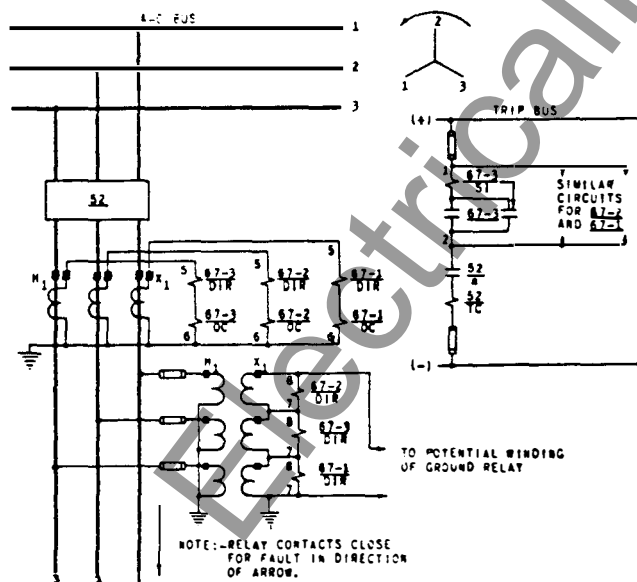

Fig. 3 60-degree Connection of Three Type IBC51A Relays Used for Directional Overcurrent Protection of a Single Line

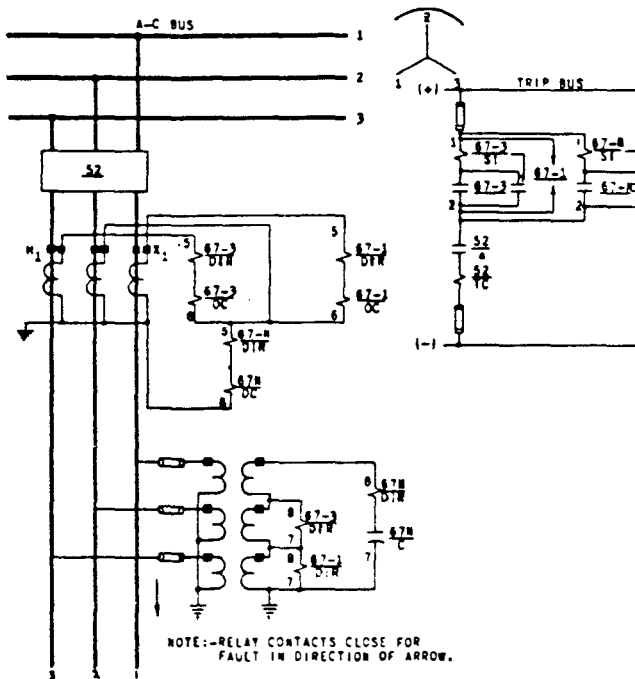

Fig. 4 External Connections of two Type IBC51A Relays Used in Conjunction with One Type IBCP51A Relay for Directional Phase-to-phase and Ground Fault

GEH-1267C Type IBC Directional Overcurrent Relays

The above distinguishing features are summarized in the table on page 9.

DIRECTIONAL UNIT

The directional unit, potential polarized, will operate properly on 1 volt and 4 amperes in relays with a 4-16 amp coil in the overcurrent unit. The directional unit of the relays with current coils rated 0.5-2.0 amps or 1.5-6.0 amps will operate properly on 1 volt and 2 amps. Current polarized directional units should operate properly at approximately 0.5 amp with the two coils in series. Figs. 9 and 10 show time curves of these units. The 230-volt rating is recommended for 199- to 240-volt applications.

OVERCURRENT UNIT

The minimum operating current required to close the contacts of this unit at any time-dial position, will be within five percent of the tap-plug setting. The contacts will reset if they are not sealed closed when the current decreases to less than 90 percent of the minimum closing value. The time for the disk to reset completely to the No. 10 time-dial position, when the relay is de-energized, is approximately six seconds for inverse-time relays.

The relay will operate repeatedly within one or two percent of the same time. The inverse-time characteristic of the overcurrent unit is shown in Fig. 17.

RATINGS

The induction element is designed to use any one of three operating coils, each having a different combination of taps as follows: 4, 5, 6, 8, 10, 12 and 16 amperes; 1.5, 2, 2.5, 3, 4, 5, and 6 amperes; 0.5, 0.6, 0.8, 1.0, 1.2, 1.5 and 2.0 amperes.

The current-closing rating of the contacts is 30 amperes for voltages not exceeding 250 volts. The current-carrying ratings are affected by the selection of the tap on the target and seal-in coil as indicated in the table on page 11.

CONDITIONS FOR MAXIMUM TORQUE IN IBC RELAYS USING 90° AND 60° CONNECTIONS

CONNECTION (1-2-3 PHASE SEQUENCE)	PHASE RELATIONSHIP AT RELAY TERMINALS FOR CURRENT FLOW- ING IN THE NON- TRIP DIRECTION AT UNITY POWER FACTOR LOAD	PHASE RELATIONSHIP AT RELAY TERMINALS FOR CURRENT FLOW- ING IN THE TRIPP- ING DIRECTION AT UNITY POWER FACTOR LOAD	VOLTAGE AND CURRENT USED IN PHASE 2 RELAY WITH PHASE RELATIONSHIP OF UNITY P.F. LOAD WHEN CURRENT FLOWS IN TRIP DIRECTION	VECTOR RELATION- SHIP OF EDDY-CU- RRENTS IN INDUC- TION CYLINDER TO FLUX SET UP BY POTENTIAL WINDING AT UNITY P.F. LOAD SHORTING LINK OFF (FREQ. - 60 CYCLES)	CONDITION FOR MAXI- MUM TORQUE WITH SHORTING LINK OFF (FREQ. - 60 CYCLES)	CONDITION FOR MAXI- MUM TORQUE WITH SHORTING LINK ON (FREQ. - 60 CYCLES)
QUADRATURE (CURRENT LEADS POTENTIAL 90 DEG- REES WHEN FLOWING IN TRIPPING DIREC- TION AT UNITY P.F. LOAD)			E_{3-1} AND I_2 			
60 DEGREE (CURRENT LEADS POTENTIAL 60 DEG- REES WHEN FLOWING IN TRIPPING DIREC- TION AT UNITY P.F. LOAD)			E_{2-1} AND I_2 			

NOTES: I_e = EDDY-CURRENT IN INDUCTION CUP, SET UP BY I
 ϕ_E = FLUX IN POTENTIAL WINDING

θ = ANGLE BETWEEN I_e AND ϕ_E
TORQUE $\propto K \phi_E I_e \cos \theta$

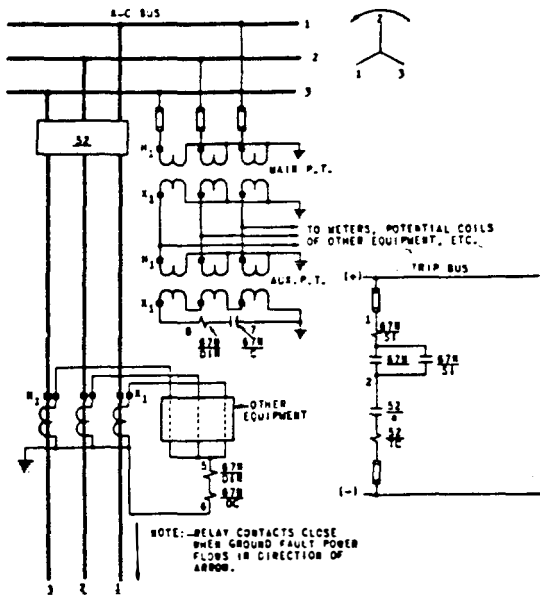

Fig. 5 External Connections of One Type IBC51A Relay Using Auxiliary Wye-Broken-Delta Transformer to Obtain Potential Polarization

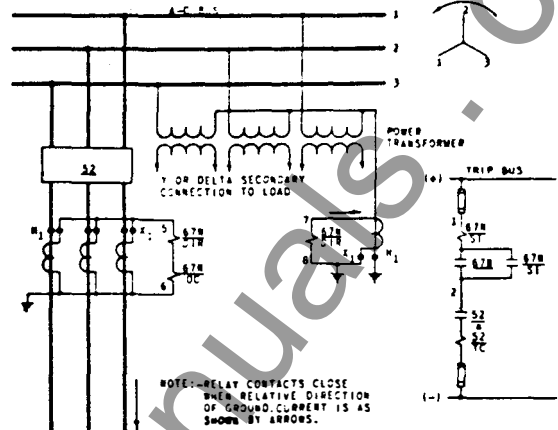

Fig. 6 External Connections of One Type IBCC51A Current Polarized Relay Used for Ground Fault Protection of a Single Line

SUMMARY OF OPERATING CHARACTERISTICS Type IBC Relays - Inverse-Type Characteristic					
Relay	Function on	Over current Unit Contacts	Directional Unit Polarized by	Phase Angle Obtained by	Approx. Angle of Max. Torque (Current with Respect to Potential)
IBC51A	Phase-to-phase and ground faults	Single-circuit Closing	Potential	Internal resistor in series with the potential coils	Internal resistor cut out, 50/60 cycles - 20-deg. lead 25 cycles - 30 deg. lead. Internal resistor in, 25/50/60 cycles - 45 deg. lead.
IBC52A	Phase-to-phase and ground faults	Two-circuit Closing	Potential	Same as IBC51A	Same as IBC51A
IBCP51A	Ground faults	Single-circuit Closing	Potential	Internal capacitor in series with potential coils	45-degree lag
IBCP52A	Ground faults	Two-circuit Closing	Potential	Same as IBCP51A	45-degree lag
IBCC51A	Ground faults	Single-circuit Closing	Current		
IBCC52A	Ground faults	Two-circuit Closing	Current		

GEH-1287C Type IBC Directional Overcurrent Relays

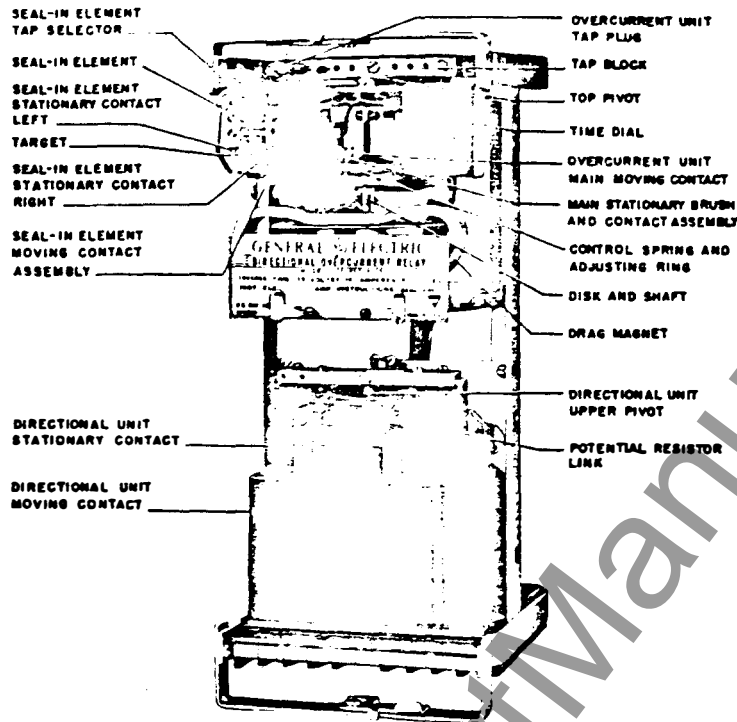

Fig. 7 The Type IBC51A Relay in the Cradle, Front View

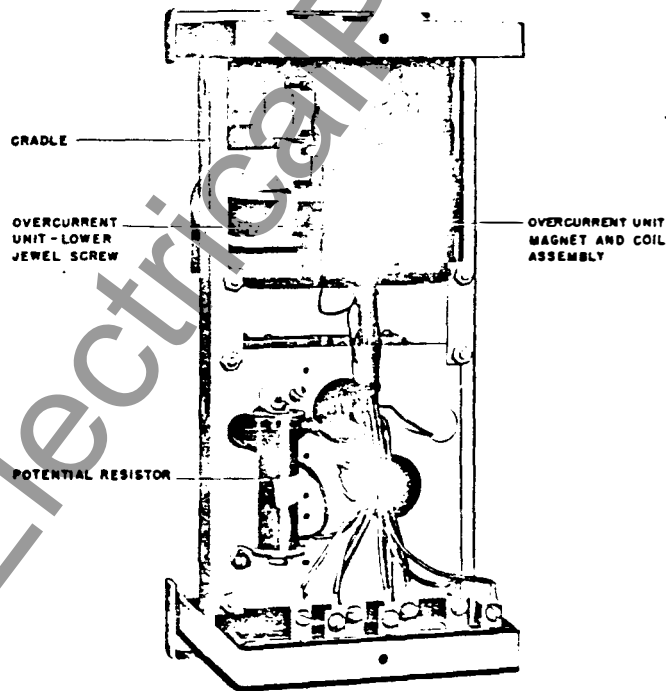

Fig. 8 The Type IBC51A Relay in the Cradle, Rear View

(8007270) Fig. 7

(8007268) Fig. 8

	Amperes, AC or DC	
	2-Amp Tap	0.2 Amp Tap
Tripping Duty	30	5
Carry Continuously	4	0.8

The 2-amp tap has a d-c resistance of 0.13 ohms and a 60 cycle impedance of 0.53 ohms while the 0.2-amp tap has a 7 ohm d-c resistance and 52 ohm 60 cycle impedance. The tap setting used on the seal-in element is determined by the current drawn by the trip coil.

The 0.2-amp tap is for use with trip coils that operate on currents ranging from 0.2 to 2.0 amperes at the minimum control voltage. If this tap is used with trip coils requiring more than 2 amperes there is a possibility that the 7-ohm resistance will reduce the current to so low a value that the breaker will not be tripped.

The 2-amp tap should be used with trip coils that take 2 amperes or more at the minimum control voltage, provided the tripping current does not exceed 30 amperes at the maximum control voltage. If the tripping current exceeds 30 amperes, an auxiliary relay should be used, the connections being such that the tripping current does not pass through the contacts or the target and seal-in coil of the protective relay.

BURDENS

In the following table the burdens are given for both ground and phase relays.

Potential Coil Burdens at 115 Volts and Rated Frequency						
Relay	Current Range In Amps	Freq.	Watts	Volt Amperes	PF	Note
IBC51A)	4-16	60	8.3	21.9	.38	(A)
IBC52A)	1.5-6	60	11.8	16.7	.71	(B)
		50	8.4	22.5	.37	(A)
		50	12.1	17.1	.71	(B)
		25	9.15	20.0	.45	(A)
IBCP51A)	0.5-2.0	60	7.0	10.	.70	(C)
		25	11.2	16.6	.68	(B)
IBCP52A)	1.5-6.0	50	7.5	10.7	.70	(C)
		25	10.0	13.6	.73	(C)

- (A) Burden with internal resistor shorted.
- (B) Burden with series internal resistance.
- (C) Capacitive

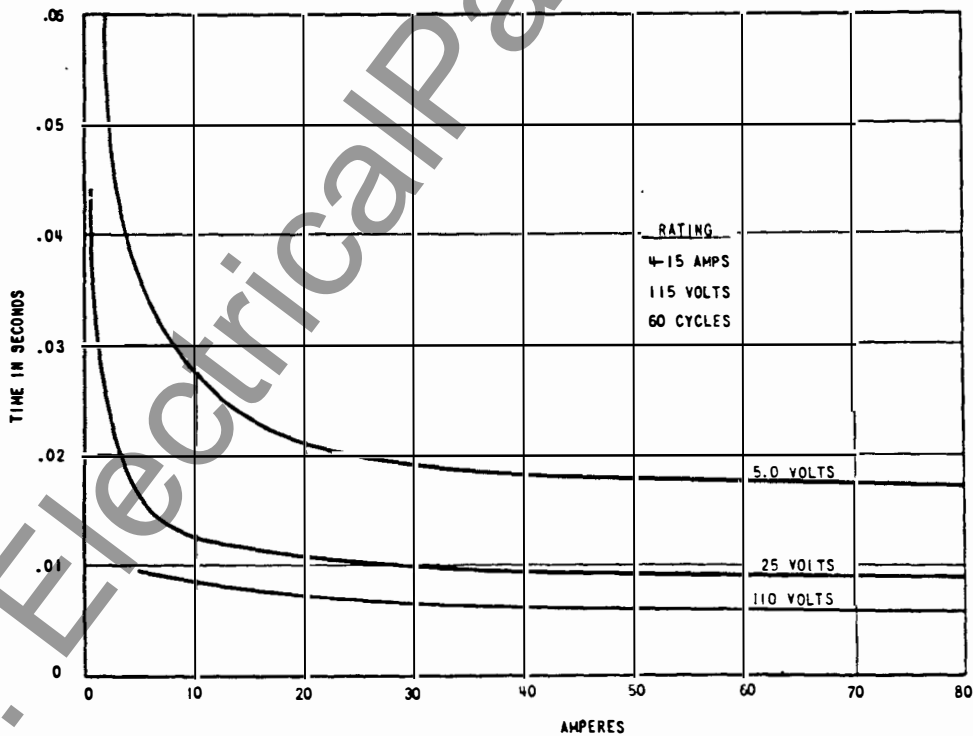

Fig. 9 Time Curves for Directional Unit of Type IBC Relays for Voltage Applied in Phase with the Current

GEH-1267C Type IBC Directional Overcurrent Relays

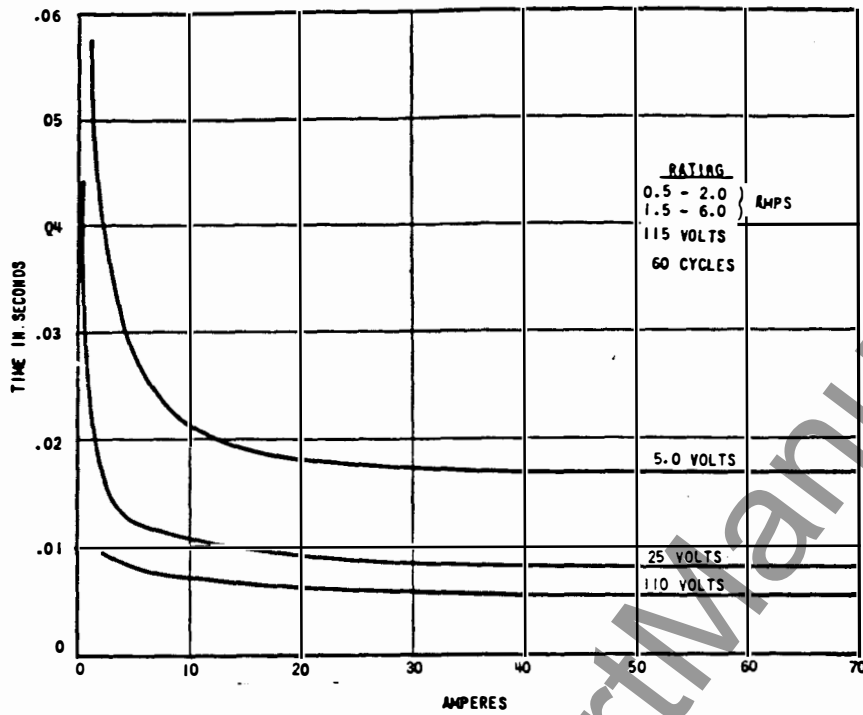

Fig. 10 Time Curves for Directional Unit of Type IBC Relays for Voltage Applied in Phase with the Current

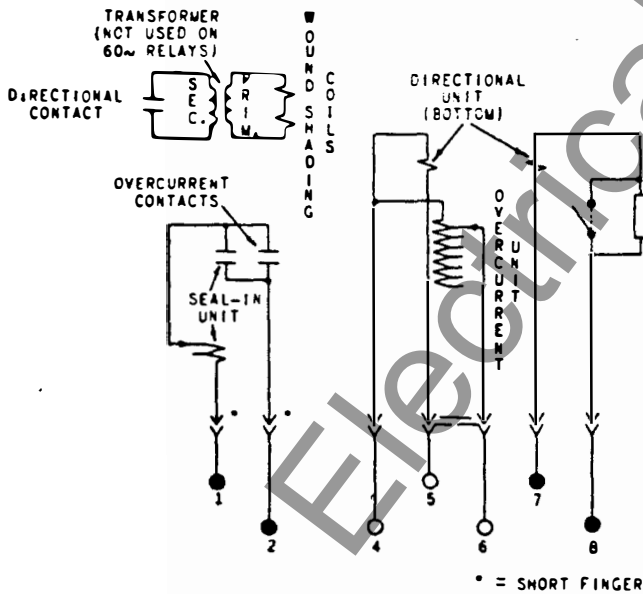

Fig. 11 Internal Connections of the Type IBC51A Relay, Front View

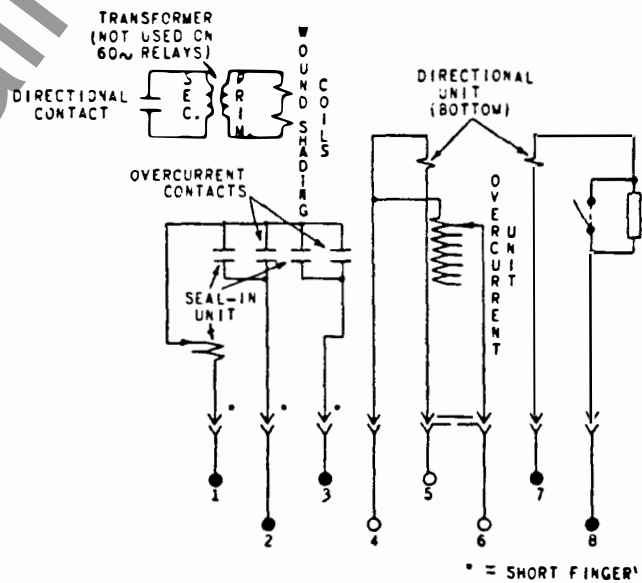

Fig. 12 Internal Connections of the Type IBC52A Relay, Front View

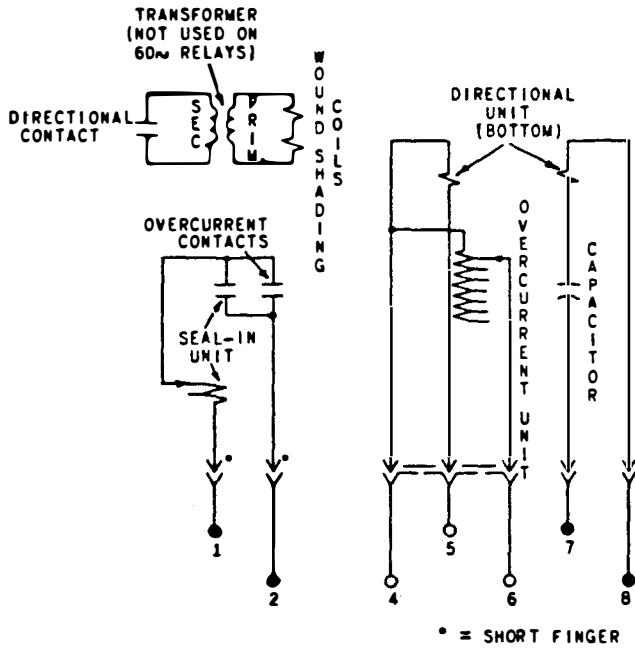

Fig. 13 Internal Connections of the Type IBCP51A Relay, Front View

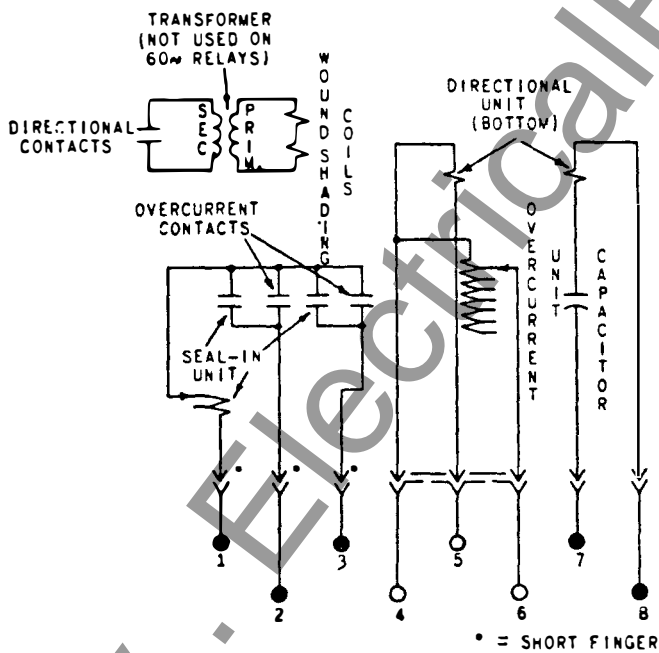

Fig. 14 Internal Connections of the Type IBCP52A Relay, Front View

Current Coil Burdens at 5 Amperes and Rated Frequency						
Relay	Current Range In Amps	Freq.	Imp.	Volt-Amperes	PF	Note
IBC51A) IBC52A)	4-16	60	.45	12.2	.38	
		50	.44	11.0	.41	
	1.5-6	25	.28	7.0	.48	
		60	3.00	76	.33	
		50	2.00	50	.35	
	25	1.6	40	.41		
IBCP51A) IBCP52A)	0.5-2.0	60	22.6	565	.33	
		50	19.2	480	.35	
	1.5-6.0	25	14.4	306	.39	
		60	3.0	76	.33	
		50	2.0	50	.35	
	25	1.6	40	.41		
IBCC51A) IBCC52A)	0.5-2.0	60	22.6	565	.33	(A)
		60	.20	5	.95	(B)
	1.5-6.0	50	19.2	480	.35	(A)
		50	.18	4.5	.96	(B)
		25	14.4	306	.39	(A)
	1.5-6.0	25	.13	3.3	.98	(B)
		60	3.0	76	.33	(A)
		60	.2	5	.95	(B)
		50	2.0	50	.35	(A)
		50	1.8	4.5	.96	(B)
		25	1.6	40	.41	(A)
		25	.13	3.3	.98	(B)

(A) Burden of operating coils of directional and overcurrent unit.

(B) Burden of current-polarizing coil of directional unit.

RECEIVING, HANDLING AND STORAGE

RECEIVING

These relays, when not included as a part of a control panel, will be shipped in cartons designed to protect them against damage. Immediately upon receipt of the relay, an examination should be made for any damage sustained during shipment. If injury or damage resulting from rough handling is evident, a claim should be filed at once with the transportation company, and the nearest Sales Office of the General Electric Company should be notified promptly.

HANDLING

Reasonable care should be exercised in unpacking the relay, in order that none of the parts are injured or the adjustments disturbed.

STORAGE

If the relays are not to be installed immediately, they should be stored in their original carton in a place that is free from moisture, dust and metallic chips.

INSTALLATION

LOCATION

The location should be clean and dry, free from dust and excessive vibration and well lighted to facilitate inspection and testing.

MOUNTING

The relay should be mounted on a vertical surface. The outline and panel drilling diagram is shown in Fig. 22.

CONNECTIONS

Internal connection diagrams for the various relay types are shown in Fig. 11 to 16 inclusive.

Typical wiring diagrams are given in Figs. 2 to 6 inclusive.

GROUND CONNECTIONS

One of the mounting studs or screws should be permanently grounded by a conductor not less than No. 12 B & S gage copper wire or its equivalent.

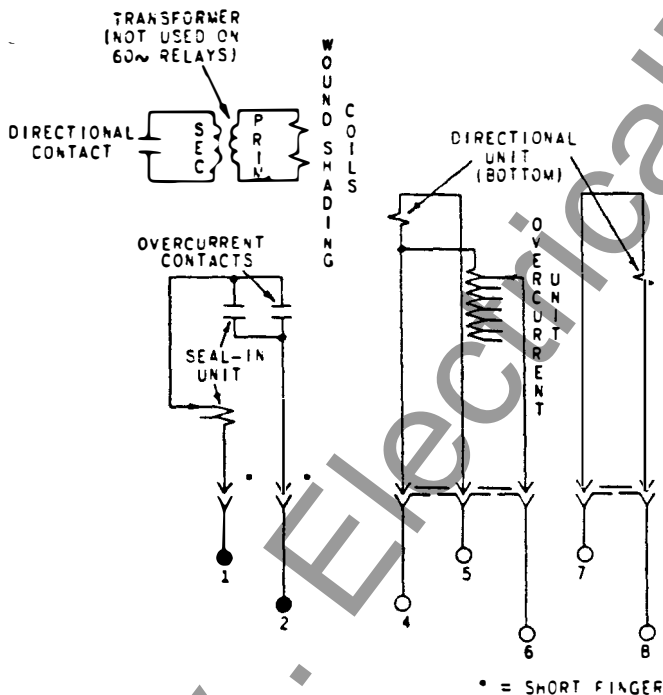

Fig. 15 Internal Connections of the Type IBCC51A Relay, Front View

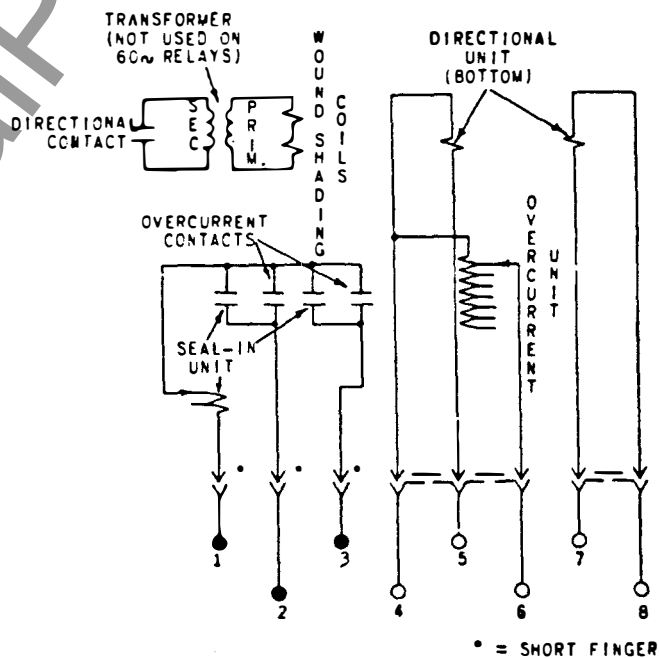

Fig. 16 Internal Connections of the Type IBCC52A Relay, Front View

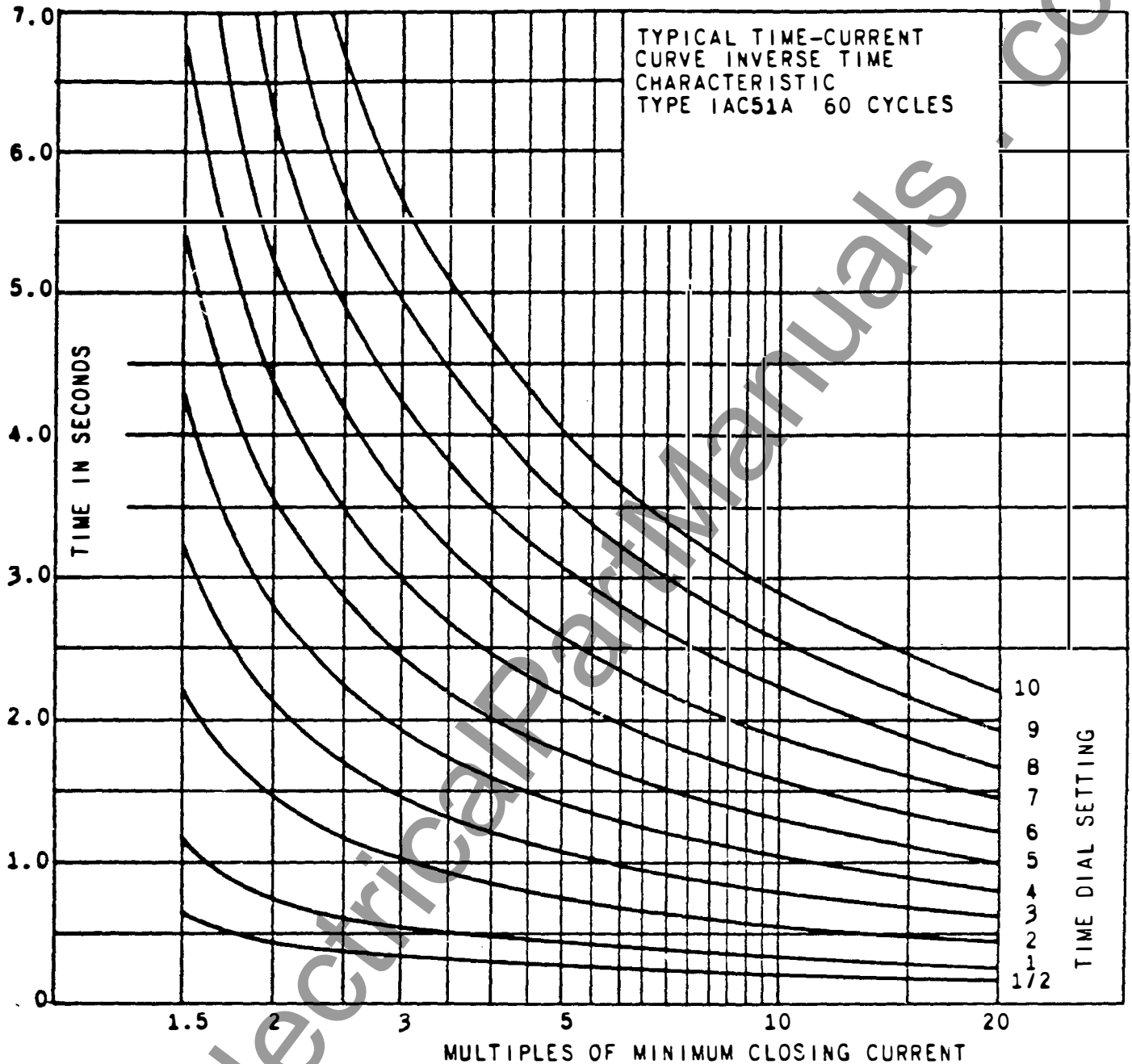

Fig. 17 Time-Current Curves for Inverse-Time Overcurrent Unit of Type IRC Relays

ADJUSTMENTS

OVERCURRENT UNIT

1. Target and Seal-in Element

For trip coils operating on currents ranging from 0.2 up to 2.0 amperes at the minimum control

voltage, set the target and seal-in tap plug in the 0.2-ampere tap.

For trip coils operating on currents ranging from 2 to 30 amperes at the minimum control voltage place the tap plug in the 2.0-ampere tap.

The seal-in element tap plug is the screw holding the right-hand stationary contact of the seal-in unit. To change the tap setting, first remove the connecting plug. Then, take a screw from the left-hand stationary contact, and place it in the desired tap. Next, remove the screw from the other tap, and place it back in the left-hand contact. This procedure is necessary to prevent the right-hand stationary contact from getting out of adjustment. If tap plugs are left in both taps, the pick-up will be less than 2.0 amperes on d-c but the seal-in element will take longer to close its contacts. On a-c, the element will not pick up with screws in both taps.

2. Current Setting

The current at which the contacts operate may be changed by changing the position of the tap plug in the tap block at the top of the relay. Screw the tap plug firmly into the tap marked for the desired current (below which the unit is not to operate).

When changing the current setting of the unit, remove the connecting plug to short circuit the current transformer secondary circuit. Next, screw the tap plug into tap marked for the desired current and then replace the connecting plug.

The pick-up of the unit for any current tap is adjusted by means of a spring adjusting ring. The ring may be turned by inserting a tool in the notches around the edge. By turning the ring, the operating current of the unit may be brought into agreement with the tap setting employed, if for some reason, this adjustment has been disturbed. This adjustment also permits any desired setting intermediate between the various tap settings to be obtained. The unit is adjusted at the factory to close its contacts from any time-dial position at a minimum current within five per cent of the tap plug setting. The unit resets at 90 per cent of the minimum closing value.

3. Time Setting

The setting of the time dial determines the length of time the unit requires to close its contacts when the current reaches a predetermined value. The contacts are just closed when the dial is set on 0. When the dial is set on 10, the disk must travel the maximum amount to close the contacts and therefore this setting gives the maximum time setting.

The primary adjustment for the time of operation of the unit is made by means of the time dial. However, further adjustment is obtained by moving the permanent magnet along its supporting shelf, moving the magnet in toward the back of the unit decreases the time, while moving it out increases the time.

If selective action of two or more relays is required, determine the maximum possible short-circuit current of the line and then choose a time value for each relay that differs sufficiently to insure the proper sequence in the operation of the

several circuit breakers. Allowance must be made for the time involved in opening each breaker after the relay contacts close. For this reason, unless the circuit time of operation is known with accuracy, there should be a difference of about 0.5 second (at the maximum current) between relays whose operation is to be selective.

4. Example of Setting

The time and current settings of the overcurrent unit can be made easily and quickly. Each time value shown in Fig. 17 indicates the time required for the contacts to close with a particular time-dial setting when the current is a prescribed number of times the current-tap setting. In order to secure any of the particular time-current settings shown in Fig. 17, insert the removable plug in the proper tap receptacle and adjust the time dial to the proper position. The following example illustrates the procedure in making a relay setting.

Assume a type IBC relay is used in a circuit where the circuit breaker should trip on a sustained current of approximately 450 amperes; also, the breaker should trip in 1.9 seconds on a short-circuit current of 3750 amperes. Assume further that current transformers of 60/1 ratio are used.

The current-tap setting is found by dividing the minimum primary tripping current by the current transformer ratio. In this case, 450 divided by 60 equals 7.5 amps. Since there is no 7.5-amp tap, the 8-amp tap is used. To find the proper time-dial setting to give 1.9 seconds time delay at 3750 amperes, divide 3750 by the transformer ratio. This gives 62.5 amperes secondary current which is 7.8 times the 8-ampere setting. By referring to the time-current curves (Fig. 17), it will be seen that 7.8 times the minimum operating current gives 1.9 seconds time delay when the relay is set slightly above the No. 6 time-dial setting.

The above results should be checked by means of an accurate timing device. Slight readjustment of the dial can be made until the desired time is obtained.

Test connections are shown in Figs. 18 and 19.

Aid in making the proper selection of relay settings may be obtained on application to the nearest Sales Office of the General Electric Company.

DIRECTIONAL UNIT

1. Potential Resistor Link

On directional units provided with an internal resistor for torque-angle adjustment, a link is located on the right-hand molded post which supports the bearing plate.

The link is used to short out the resistor; and when so connected, the angle of maximum torque occurs with the current leading 20 degrees (approx.) on 50/60 cycles and 30-degree leading on 25 cycles. For 45-degree lead, the link is disconnected and

K-6154287 Fig. 18
K-6154288 Fig. 19

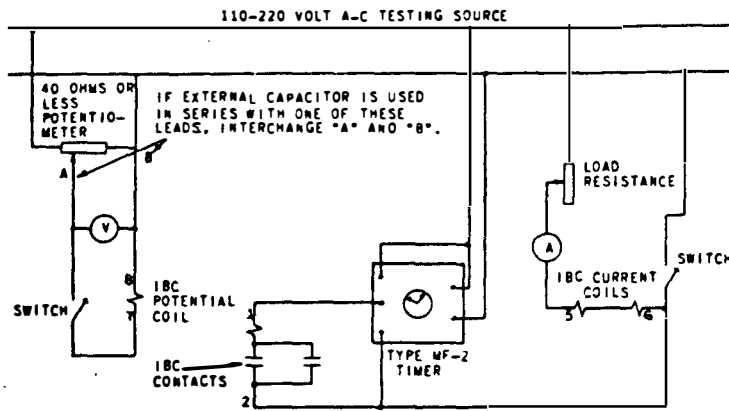

Fig. 18 Testing Connections for Potential Polarized Relays Such as Type IBC51A

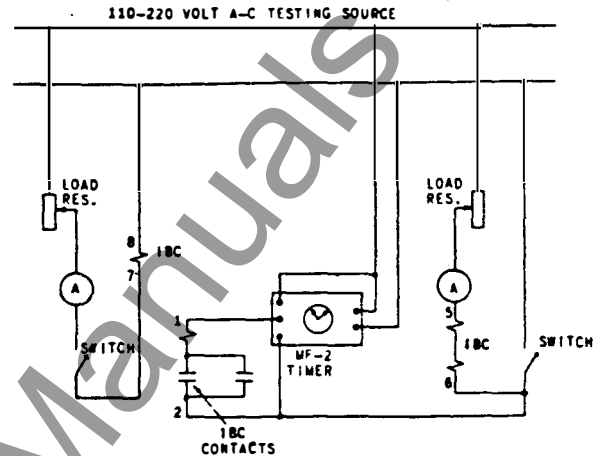

Fig. 19 Testing Connections for Current Polarized Relays Such as Type IBCC51A

turned in a counterclockwise direction from its top fastening screw. It is left attached by the lower screw so as not to be lost from the relay.

2. Polarity Check

The polarity of the directional-unit connections in phase-to-phase fault applications may be verified by observing the direction of contact armature torque when the line is carrying load at unity power factor, or slightly lagging power factor. Note that in most directional overcurrent relay applications, the desired directions are: contact-closing for power flow away from the bus, and contact-opening for power flow toward the bus.

The ground relay connections are shown in Figs. 4 to 6. The following tests should be made on the ground element to insure that the currents, or current and voltage, go to the proper relay terminals.

The polarity of the potential-polarized, ground directional unit may be checked by using load currents. The idea is to obtain current from one transformer and voltage from the same phase. The voltage is obtained by removing phase one from the primary of the broken-delta transformer and shorting the phase one primary winding to ground. Current is obtained by shorting the current transformers in phases two and three and opening their circuits to the relay. This permits the current transformer in phase one to supply the current.

Connect a phase-angle meter to read the angle between the current and voltage supplied to the relay. The relay has maximum torque at 45 degree lag. With power flowing in the proper direction for operation, the relay should operate for phase angles within plus or minus 60 degrees of the maximum torque angle.

If the unit is polarized from a current transformer in the power-transformer neutral, such a check is not easily made. It is sometimes practical to introduce a single-phase current in one phase of the primary circuits in such a way that current flows through both the transformer neutral current transformer and one of the line current transformers. If this cannot be done, a careful wiring check must suffice.

The polarity of the type IBC relay directional units can be checked with the circuits given in Fig. 20. When connected as shown for the particular relay the contacts will close with rated voltage and frequency.

3. Inspection

At the time of installation, the relay should be inspected for tarnished contacts, loose screws, or other imperfections. If any trouble is found, it should be corrected in the manner described under "Maintenance".

OPERATION

Before the relay is put into service it should be given a partial check to determine that factory ad-

adjustments have not been disturbed. The time dial will be set at zero before the relay leaves the fac-

tory. It is necessary to change this setting in order to open the overcurrent contacts.

MAINTENANCE

These relays are adjusted at the factory and it is advisable not to disturb the adjustments. If for any reason, they have been disturbed, the following points should be observed in restoring them:

DISK AND BEARINGS - OVERCURRENT UNIT

The lower jewel bearing may be tested for cracks by exploring its surfaces with the point of a fine needle. If it is necessary to replace the jewel bearing, a very small drop of G-E Meter Jewel Oil, Cat. No. 66X728, should be placed on the new jewel before it is inserted. A new pivot should be screwed into the end of the disk shaft at the same time. The overcurrent unit jewel bearing should be turned up until the disk is centered in the air gaps, after which it should be locked in position by the set screw provided for the purpose.

The upper bearing pin should be adjusted so that the disk shaft has about 1/64-in. end play.

CONTACTS - OVERCURRENT UNIT

The contacts should have about 1/32-in. wipe. That is, the stationary contact tip(s) should be deflected about 1/32-in. when the disk completes its travel. Wipe is adjusted by turning the screws in the contact brush(es) thereby adjusting the position of the brush(es) relative to the brush stop. The tips should lie in the same vertical plane on two-circuit closing relays.

When the time dial is moved to the position where it holds the contacts just closed, it should indicate zero on the time-dial scale. If it does not, and the brushes are correctly adjusted, shift the dial by changing the position of the arm attached to the shaft just below the time dial. Loosen the screw clamping the arm to the shaft and turn the arm relative to the shaft until the contacts just make for zero time-dial setting.

CONTACT CLEANING - BOTH UNITS

For cleaning fine silver contacts, a flexible burnishing tool should be used. This consists of a flexible strip of metal with an etched roughened surface, resembling in effect a superfine file. The polishing action is so delicate that no scratches are left, yet corroded material will be removed rapidly and thoroughly. The flexibility of the tool insures the cleaning of the actual points of contact. Sometimes an ordinary file cannot reach the actual points of contact because of some obstruction from some other part of the relay.

Fine silver contacts should not be cleaned with knives, files or abrasive paper or cloth. Knives or files may leave scratches which increase arcing and deterioration of the contacts. Abrasive paper

or cloth may leave minute particles of insulating abrasive material in the contacts and thus prevent closing.

The burnishing tool described in the preceding section, can be obtained from the factory.

CONTACTS - DIRECTIONAL UNIT

The contacts of the directional unit, Fig. 21, are specially constructed to suppress bouncing. The stationary contact (G), is mounted on a flat spiral spring (F) backed up by a thin diaphragm (C). These are both mounted in a slightly inclined tube (A). A stainless steel ball (B) is placed in the tube before the diaphragm is assembled. When the moving contact hits the stationary contact, the energy of the former is imparted to the latter and thence to the ball, which is free to roll up the inclined tube. Thus, the moving contact comes to rest with substantially no rebound or vibration. To change the stationary contact mounting spring, remove the contact barrel and sleeve as a complete unit after loosening the screw at the front of the contact block. Unscrew the cap (E). The contact and its flat spiral mounting spring may then be removed.

The contact gap may be adjusted by loosening slightly the same screw at the front of the contact block. The screw should be loose enough only to allow the contact barrel to rotate in its sleeve.

The stop screw fastened with a locknut should hold the moving contact arm in a neutral position, i.e., with it pointing directly forward. Then bring the stationary contact up until it just touches the moving contact by rotating the contact barrel. Next, back it away 2/3 turn to obtain approximately 0.020 in. contact gap. Last, tighten the screw which secures the barrel.

The moving contact may be removed by loosening the screw which secures it to the contact arm and sliding it from under the screw head.

CUP AND STATOR - DIRECTIONAL UNIT

Should it be necessary to remove the cup-type rotor from the directional unit the following points should be followed:

1. Disconnect the two leads from the resistor and two leads from the secondary of the transformer at the contact block structure.
2. Remove unit intact with its mounting plate.
3. Avoiding any disturbance to the top bearing plate, remove the entire top structure from the stator assembly by removal of the four corner

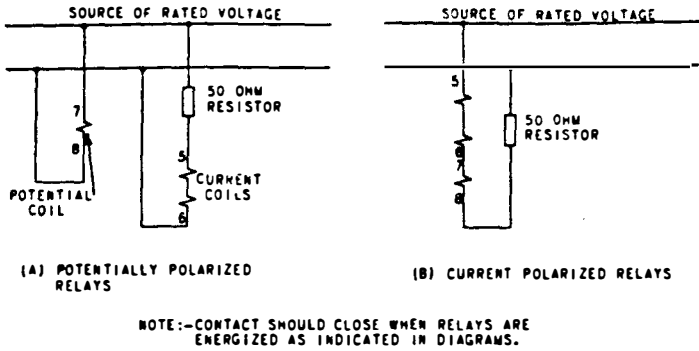

Fig. 20 Polarity Test Connections for Type IBC Relays

screws. This will give access to the cup and stator assembly.

4. In this way all parts will again be aligned by the pins when replaced.

CLUTCH ADJUSTMENT - DIRECTIONAL UNIT

Clutch adjustment is made with connections similar to those for the polarity check, Fig. 20, except that the 50-ohm fixed resistor should be replaced by an adjustable resistor capable of controlling the current in the current coil(s) between 5 and 15 amperes. A screw on the side of the moving contact arm controls the clutch pressure. Using rated frequency (and voltage for potential polarized relays) the clutch should be set to slip at the proper current as shown in the table below:

Polarization	Pickup Amps Rating	Position of Shorting Link	Amps for Clutch to Slip
Potential	4-16	Closed	12.7
Potential	1.5-6.0	Closed	8.5
Current	0.5-2.0		
	1.5-6.0		7.
	0.5-2.0		

BEARINGS - DIRECTIONAL UNIT

The lower jewel bearing should be screwed all the way in until its head engages the end of the threaded core support. The upper bearing should

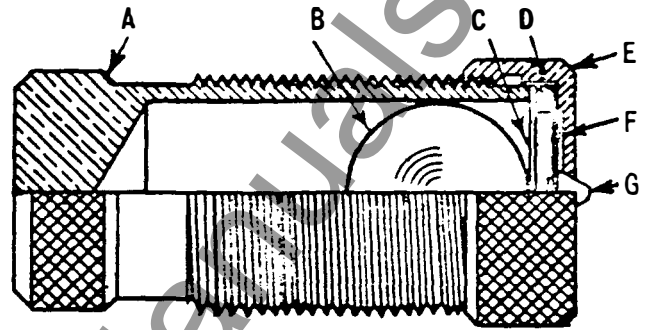

Fig. 21. Contact Assembly for Directional Unit

be adjusted to allow about 1/64-in. end play to the shaft.

To check the clearance between the iron core and the inside of the rotor cup, press down on the contact arm near the shaft and thus depress the spring-mounted jewel until the cup strikes the iron. The shaft should move about 1/16 inch.

The lower jewel bearing may be tested for fracture by exploring its surface with the point of a fine needle. If it is necessary to replace the jewel bearing, a very small drop of General Electric meter jewel oil, Cat. N. 66X728, should be placed on the new jewel before it is inserted. A new pivot should be screwed into the end of the shaft at the same time.

TORQUE ADJUSTMENT - DIRECTIONAL UNIT

The spiral spring on the contact shaft should have barely enough tension to return the moving contact arm to the neutral position where it rests against the stop screw when de-energized. Its tension may be varied by slipping the adjusting ring by first loosening the hexagonal head locking screw which connects the lead to this lead-in spiral spring. Sufficient tension will be had when this ring is rotated in the counterclockwise direction about 1/2 inch from the neutral position as measured on the periphery of the ring.

Torque adjustment is only necessary on the phase fault relays as these relays are provided with a notched core. The ground relays have an unnotched core.

GEH-1267C Type IBC Directional Overcurrent Relays

The current coil of the phase-to-phase fault relays should be energized, with the potential coil shorted, by the following values of current corresponding to its rating.

Current Rating	Test Amp.
0.5-2.0)	30
1.5-6.0)	
4-16	60

With the spring tension such as to balance the moving contact structure between the stationary contact and the stop, the core should be turned to keep it in this same position when the above test amps are applied with shorted potential coil. The core is turned with a screw driver, in the lower

bearing screw slot, after first loosening the locknut holding it in place. Keep the lower bearing screw tight in the core support. Tighten the locknut after each adjustment.

The above test should be made with the internal resistor shorted with the link; also, it should be kept in mind that the coils will overheat with too frequent applications of large currents so that sufficient time should be allowed for them to cool between tests.

PERIODIC TESTING

An operation test and inspection of the relay at least once every six months are recommended. Test connections are shown in Figs. 18 and 19.

RENEWAL PARTS

It is recommended that sufficient quantities of renewal parts be carried in stock to enable the prompt replacement of any of those worn, broken or damaged.

ORDERING INSTRUCTIONS

When ordering renewal parts, address the near-

est Sales Office of the General Electric Company, specify quantity required, name of part wanted and give complete nameplate data including serial number. If possible, give the General Electric Company requisition number on which the relay was furnished.

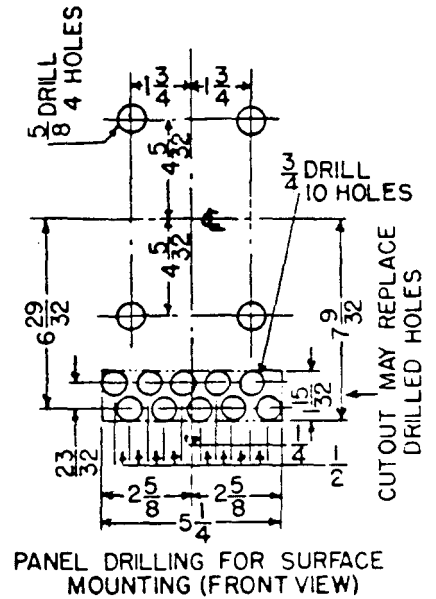
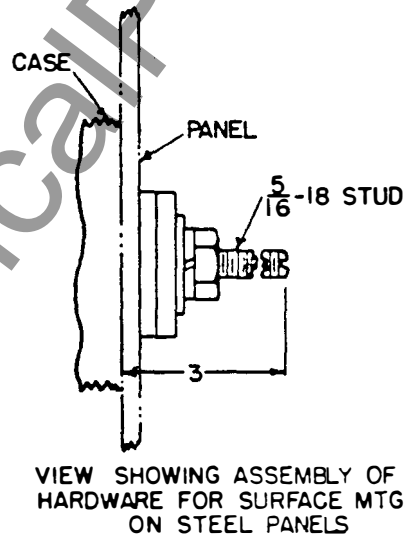
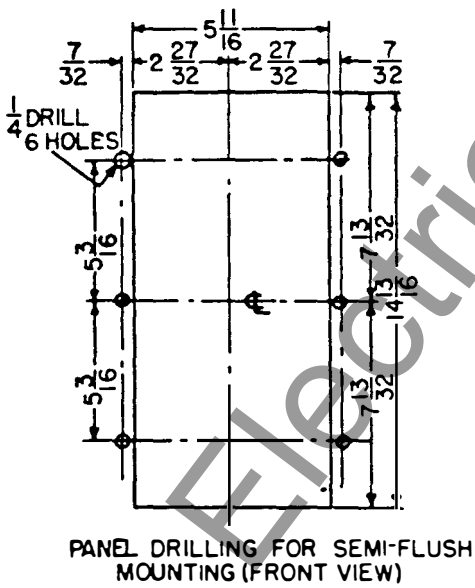
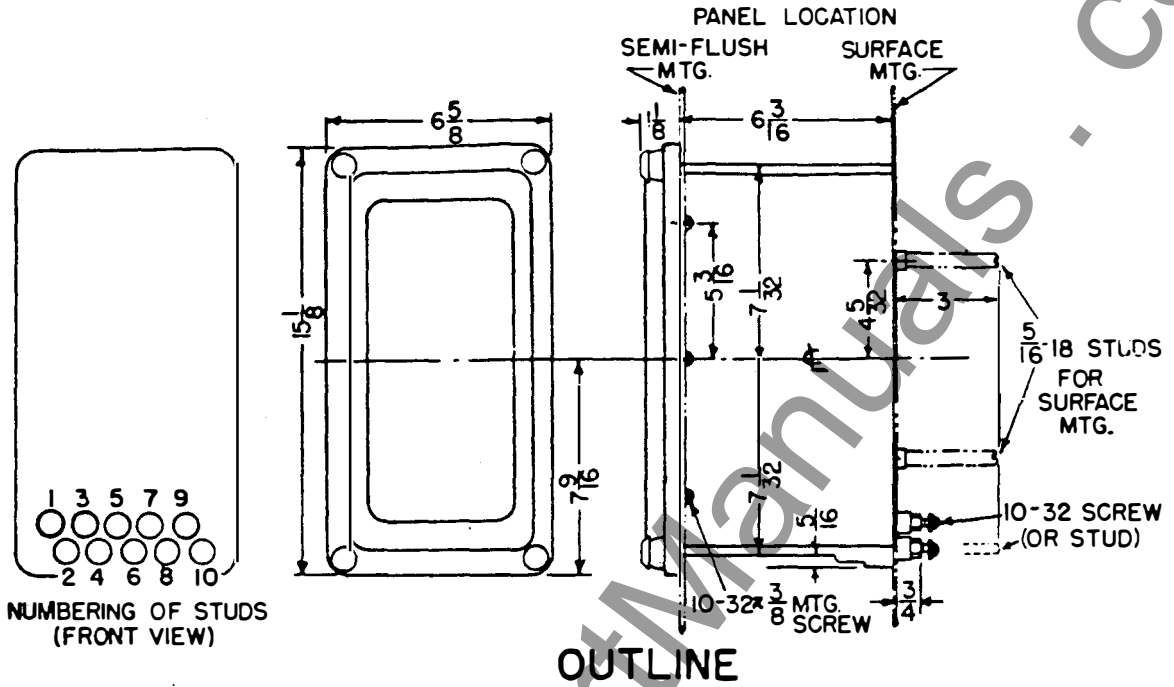

Fig. 22 Outline and Panel Drilling for Type IBC Relays

www.ElectricalPartManuals.com