



TYPE LF-25H230 and LF-50H230 AC CONTACTORS

HIGH VOLTAGE

AIR BREAK

DESCRIPTION

APPLICATION

The Type LF-25H230 and LF-50H230 contactors are designed for starting and controlling three phase, 50-60 cycle a-c motors on 2200-2500 volt and 4000-5000 volt systems respectively, having horsepower ratings as shown in Table 1. These contactors have maximum 8 hour open ratings of 200 amperes, but may also be used for lower currents.

Both the Type LF-25H230 and LF-50H230 contactors have interrupting ratings of 25,000 KVA, but when used in NEMA class E2 controllers, where current limiting fuses limit and interrupt short circuit current, the Type LF-25H230 contactor may be used on circuits having capacities up to 150,000 KVA and the Type LF-50H230 contactor may be used on circuits having capacities up to 250,000 KVA, as shown in Table 1.

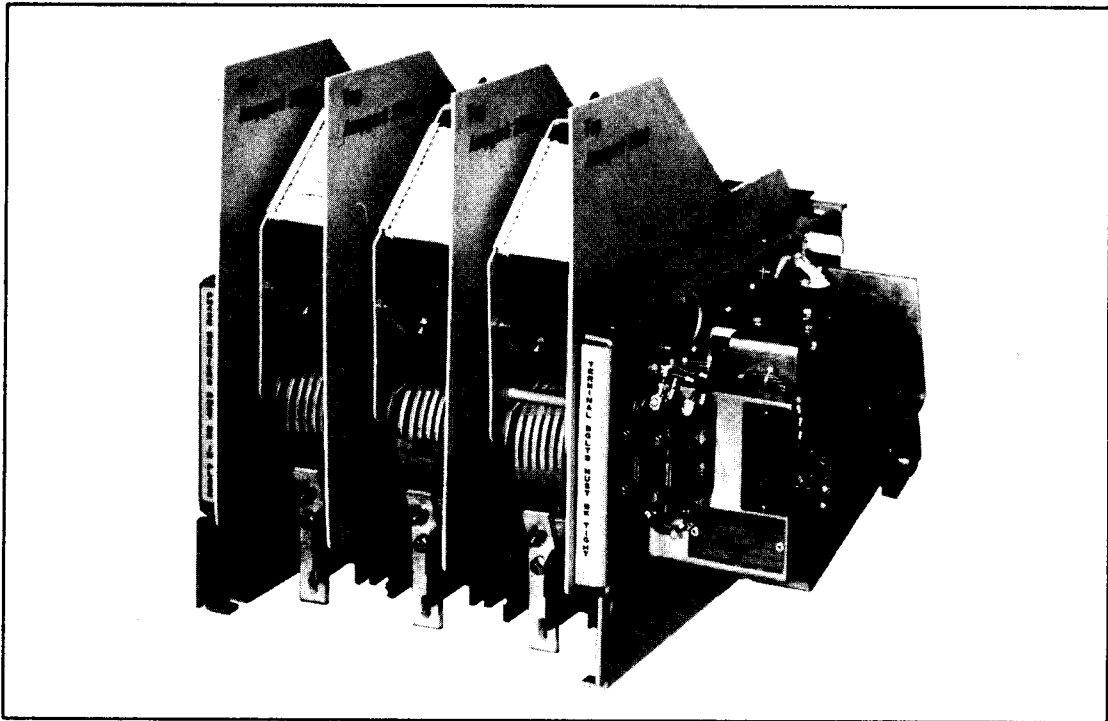

Fig. 1 Type LF-25H230 Contactor

(70-0401)

TABLE 1

Contactor Type	Contactor 8 Hour Rating (Amperes)		System Voltage	Horsepower Rating			Controller Interrupting Capacity — 3 Phase Symmetrical KVA	
				Synchronous Motor		Induction Motor		
	Open	Enclosed		100% P.F.	80% P.F.			NEMA E 1
LF25H230	200	180	2200-2500	900	700	700	25,000	150,000
LF50H230	200	180	4000-5000	1500	1250	1250	25,000	250,000

GENERAL DESCRIPTION

The Types LF-25H230 and LF-50H230 AC contactors are compact, light weight, 3 pole, DC magnet closed devices employing single break contacts with weld resistant alloy faces, and series connected electromagnetic blowout coils. The moving contact assemblies are mounted on track resistant and fire retardant insulating material molded directly to a round steel shaft, which is supported by self-aligning ball bearings mounted in vertical end plates. The stationary contact assemblies and fuse supports are mounted in insulating supports which, in turn, are mounted on a steel channel supported between the contactor end plates. The magnetic blowout coil assemblies are bolted to an insulating cross member. The arc chute assemblies are pivoted on the blowout cores, and can be rotated out of normal operating position to provide convenient access for contact maintenance. Arc resistant and flame retardant insulating barriers are mounted between phases and also between the two outside poles and the contactor end plates.

OPERATING MAGNET

In order to isolate the low voltage control circuits from parts energized by high voltages and to achieve maximum accessibility, the d-c clapper type operating magnet is mounted on the outside of the right hand end plate. The magnet armature is clamped to an un-insulated portion of the main moving contact shaft which projects through the right hand contactor end plate. The magnet armature is adjusted and locked in position by means of locknuts and a stud, which engages an operating arm clamped and keyed to the same shaft. This adjustment controls the main contact overtravel so that both measurement and adjustment of contact overtravel can be made simply, in an accessible location.

When an a-c control circuit is used, a rectifier to convert the a-c control power to d-c power for the coil must be provided. No provision is made for mounting this item on the contactor since it is normally mounted on a control panel, along with other low voltage control components. However, the appropriate rectifier may be ordered by referring to the style numbers listed in Table 2. The operating coil and electrical inter-

lock wiring is terminated at a plug mounted on the right hand end plate.

CONTACT STRUCTURE

The stationary contact assemblies are mounted in three molded insulators which provide:

- a) The stationary contact supports.
- b) The fuse jaw for the load side of current limiting fuses, for use when the contactor is built into a fused controller.
- c) Stab type line connectors. These may be used for the main line connections when fuses are not used. When fuses are used, these stabs may be used to energize the control transformer. They may also be used for reversing and reduced voltage starter applications.
- d) Provision for bolted line connections as an alternative to stab connections and where fuses are not used.

The stationary contacts are bolted to the front ends of the copper fuse support castings where they are easily inspected or replaced. They are a heavy copper section provided with weld resistant silver alloy faces.

The moving contact support assemblies are clamped to the insulated shaft, and include a pivoted copper section which supports the moving contact, and provides a terminal point for the flexible shunt. The stationary and moving contacts are identical.

ARC CHUTE

The arc chute assemblies consist of a single cemented grid stack, arc resistant arc shields, and copper arc horns, bolted and clamped securely in place between arc and flame retardant arc chute sides. The arc chute assemblies are supported by the magnetic blowout pole pieces which are permanently attached to the arc chute sides and are, in turn, bolted to the magnetic blowout cores. The blowout pole pieces have open end slots for bolting to the blowout cores, so that it is only necessary to loosen the blowout core bolts to remove the arc chute assemblies.

TABLE 2

AC Control Voltage	Nominal Coil Voltage (DC)	Rectifier Unit S#	Coil S#	Protective Resistor S#
115	100	2018A40G01	636C392G02	2018A22H01 (50 Ohms)
230	200	2018A40G02	636C392G03	2018A22H02 (150 Ohms)

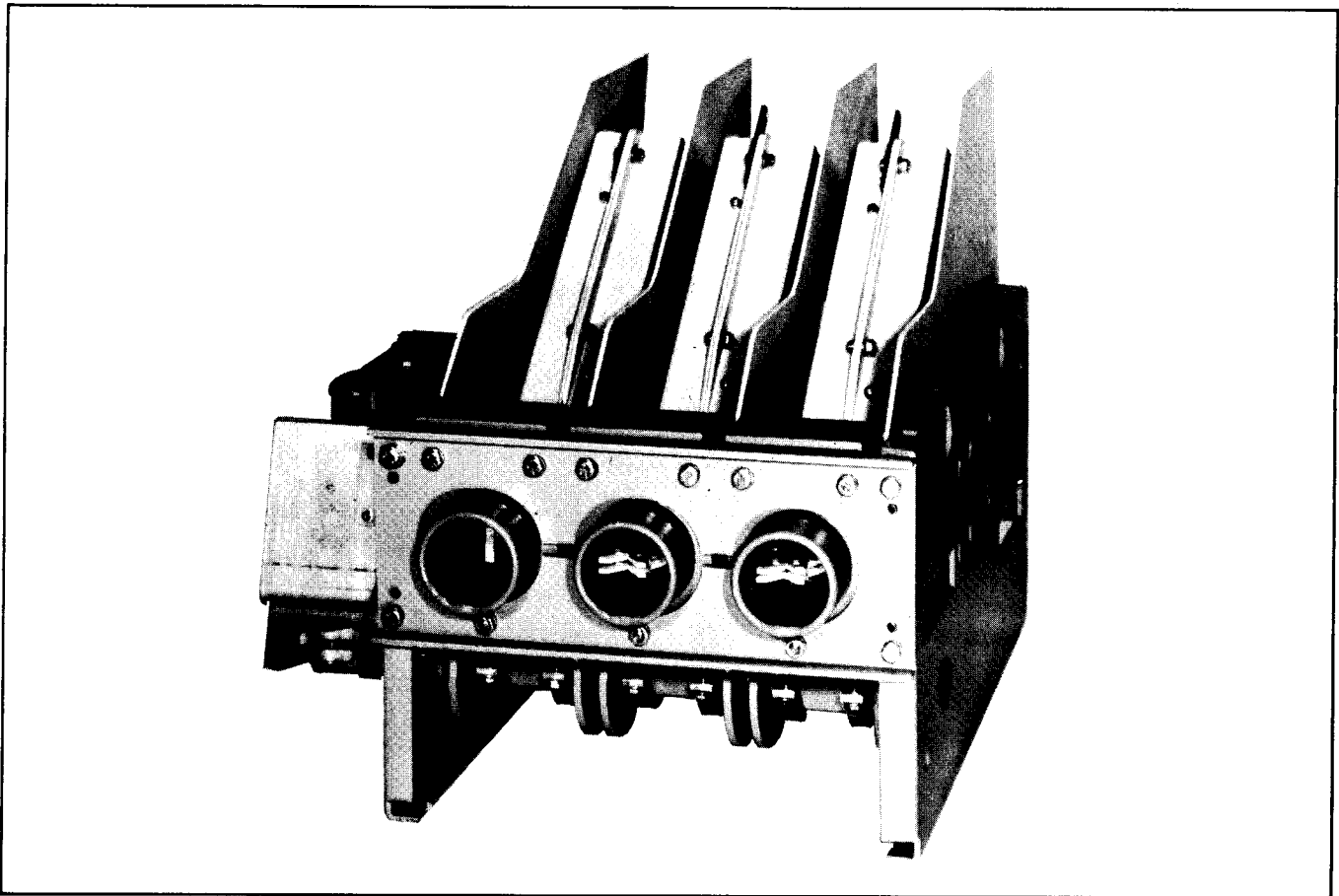

Fig. 2 Rear View of Type LF-25H230 Contactor

(70-0400)

The blowout cores are free to rotate in their mounting supports, thus permitting the arc chutes to be rotated out of their normal operating position to provide convenient access for contact inspection or replacement, and for arc chute inspection. When the arc chutes are in their normal operating position, electrical connections to the arc horns, mounted within the arc chutes, are completed through knife jaw assemblies mounted adjacent to the moving and stationary contacts.

In the operating position the arc chute grid stacks are tilted forward at an angle so that hot gases, generated during arc interruption, are directed towards the front of the starter enclosure, and away from the vicinity of energized components and connections.

ELECTRICAL INTERLOCKS

Two type L-64 electrical interlocks are mounted in front of the magnet to provide four auxiliary circuits for use in the starter control circuits. Any combination

of normally open or normally closed circuits is available by selection of the appropriate style of interlocks shown below.

Actuation of the interlocks is by a lever pivoted on the interlock mounting and operated by a pin on the magnet armature. The lever has adjustable operating screws that actuate the L-64 interlock plungers.

A third L-64 electrical interlock with two normally closed contacts is mounted on the magnet frame. This is reserved for use in the coil circuit to insert a protective resistor in series with the magnet coil when the armature is sealed. The location of these interlocks is shown in figure ③.

L-64 INTERLOCKS

Interlock Style	Circuit Combination Provided by One Interlock Assembly
843D943G04	One normally open, one normally closed
843D943G05	Two normally open
843D943G06	Two normally closed

MAINTENANCE AND REPAIR

The following sections describe the recommended maintenance and repair procedures, including details of the various contact gaps and forces, etc.

GENERAL

A maintenance program should be established as soon as the contactor is installed and put into operation. After the contactor has been inspected a number of times at monthly intervals, and the condition noted, the frequency of inspection can be increased or decreased to suit the conditions found, since this will depend upon the severity of the contactor duty.

CAUTION: All work on this contactor should be done with the main circuit disconnect device open, using a separate source of control power to operate the magnet.

HANDLING

Two men can lift and carry the contactor. Handholes are provided in the left hand end plate, and handholes can be obtained on the magnet side by placing one hand under the bracket supporting the interlocks, and the other hand under the shaft behind the magnet.

Additional lifting holes are provided at the top edge of both right and left hand end plates for use with lifting hooks or ropes. Remove the outer phase barriers to obtain full access. By removing all 4 phase barriers, and rotating all 3 arc chutes forward, lifting bars may be inserted to pass through both end plates to provide even greater convenience in handling.

INSULATION LEVEL

After installation, and before energizing the contactor for the first time, the insulation resistance between poles, and from each pole to ground, should be measured and recorded. It is not practical to specify an absolute value for this reading since it is dependent on other connected apparatus, and conditions of service. However, any abrupt reduction in this reading would indicate a possible source of trouble, and the cause should be established and immediately corrected.

MAIN CONTACTS AND SHUNTS

To obtain access to the contacts, either for examination or replacement, pull the arc chutes forward to rotate them out of the normal operating position, and remove the four barriers.

The general condition of the connections and shunts should be noted, especially any discoloration, which would indicate excessive heating due to loose hardware, high current, or low contact force. Since silver alloy contact faces are used, dressing or filing of the contacts is not required.

When replacing contacts, make sure that they sit flat against the contact supports and tighten the bolts firmly until the lock washers are fully compressed. Check, and if necessary, adjust the contact overtravel, and see that all contacts touch simultaneously. Use the following procedure:

- 1) Move the contacts to the contact touch position by blocking or operating the magnet armature by hand.
- 2) Check that all contacts touch simultaneously, within $1/32''$. Adjustment to satisfy this condition is obtained by a selective tightening of the four bolts clamping a moving contact support assembly to the insulated contact shaft, to produce a slight rotation of the assembly on the shaft.
- 3) Check that all three contacts line up laterally within $1/32''$, at the contact touch position.

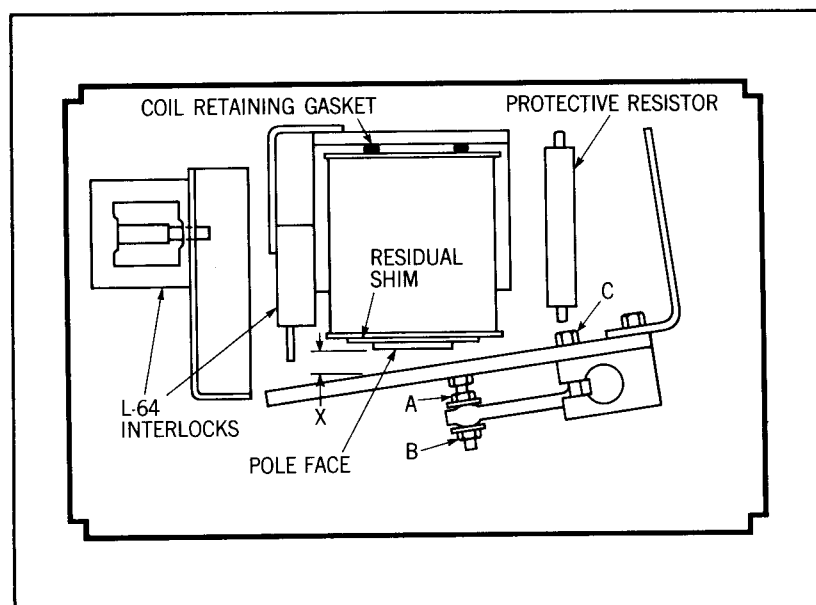

Fig. 3 Operating Magnet and Contact Overtravel Adjustment

CONTACT OVERTRAVEL AND FORCES

The gap "X" (shown in Fig. ③) with the armature closed to the contact touch position, is a convenient measure of contact overtravel. With new contacts, contact overtravel will be correct when the gap "X" is $.40 \pm .02$ ".

If it's necessary to adjust contact overtravel, proceed as follows:

- 1) Loosen the two bolts "C" in Fig. ③, which clamp the magnet armature to the shaft.
- 2) Block the magnet armature in the contact touch position.
- 3) Adjust the locknuts "A" and "B" in Fig. ③ either up or down, and lock them in position when the gap at "X" is $.40 \pm .02$ ".
- 4) Retighten the two bolts "C".

NOTE The main contacts should be replaced when gap "X" has decreased to $1/8$ ", with all three contacts making contact.

The procedures outlined above, provided they are done when new contacts are fitted, will automatically set the contact forces; however, the contact forces should be checked as a matter of routine. They are measured at

the front edge of the moving contact face, perpendicular to the floor. This is shown in Figure ④. Measured at this point, the contact forces with new contacts should be:

Initial force — 5.4 - 7.2 lbs.

Final force — 17.2 - 19.7 lbs.

Failure to fall within limits would indicate either:

- a) An incorrect overtravel adjustment (final force only)
- b) Weak, broken or incorrect contact springs

Examine the lower fuse finger mounted at the rear of the stationary contact support. The contact surfaces should be clean, and the fuse finger should pivot smoothly. Check the initial spring force. Measured at the point of contact with the fuse, this initial force should be 19 ± 2 lbs. for the Type LF-25H230 Contactor or 22 ± 2 lbs. for the Type LF-50H230 Contactor.

OPERATING MAGNET

The section above, dealing with main contact overtravel, also covered the principal magnet adjustment since this controls the contact overtravel.

In carrying out general inspections, operate the magnet armature by hand. Any friction should be investigated and corrected. Check that the armature seats squarely without hitting the magnet pole face bolts.

REPLACING COILS

To change operating coils, proceed as follows:

- 1) Disconnect the leads from the coil terminals.
- 2) Remove the core bolt located on top of the magnet frame.
- 3) The coil, magnet core and pole face can now be removed as a complete assembly, thus permitting easy coil removal and replacement.

Reverse the procedure to reassemble, making sure the residual shim is nearest the pole face, and the coil retaining gasket on top of the coil.

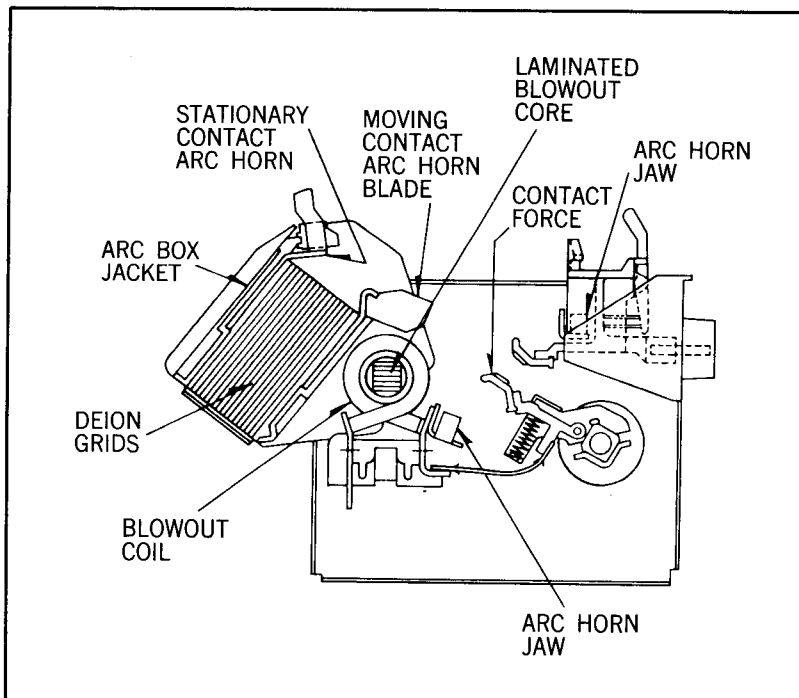

Fig. 4 Type LF-50H230 Contactor with Arc Chutes Rotated Forward for Inspection

ARC CHUTES

Usually, the arc chutes require little or no maintenance, but it is convenient to check them whenever the main contacts are examined or changed.

With the arc chutes pulled forward out of the operating position, examine the copper arc horns and the insulating supports for excessive arc erosion; also examine the arc shields at each side of the arc chute and the grid stack assembly for either excessive arc erosion or metal deposits, and for cracks. Examine the two knife switch blades at the ends of the arc horns, and the corresponding knife switch jaws mounted adjacent to the contacts, to ensure good contact surfaces. Check the deflection of the knife switch jaws when the blade is engaged, since this deflection indicates the presence of contact pressure. Visual inspection of the jaws adjacent to the moving contacts is difficult when the arc chutes are in the operating position. In this case, the deflection should be checked either by measurement of the gap at the jaws, or by placing a finger tip at the edge of the jaw, and closing the arc chute gently so as to feel the deflection. These knife switch assemblies carry current only while an interruption is taking place.

If more detailed examination is desired, or if, after prolonged use, there is sufficient arc erosion to require replacement of parts, the arc chutes may be removed and dismantled as follows:

- 1) With the arc chutes in the operating position, loosen the two blowout core bolts fastening the blowout pole pieces mounted on the arc chute.
- 2) Rotate the arc chutes forward, lift, and pull them loose from the contactor blowout core bolts.
To dismantle the arc chutes, continue as follows:
- 3) With the arc chute placed in its normal position remove the 1/4-20 hardware bolting the flanged joint along the rear of the arc chute; loosen the grid stack clamping screw in the front. Remove the three remaining 1/4-20 nuts located in the lower half of the arc chute. Leave intact the two 10-32 screws holding the arc shields to the arc chute side.
- 4) Lay the arc chute on its right side. Remove the 10-32 screws on either side of the flange.
- 5) Remove the left hand arc chute side. The two arc horn assemblies and the grid stack can now be lifted out, and the two screws holding the arc

shields can be removed if arc shield replacement is necessary.

- 6) The arc horns are mounted on their supports by two 10-32 x 3/8 binding head screws. These too can now be removed.

This completes the dismantling of the arc chute. To reassemble the arc chute continue as follows:

- 1) Attach the arc shields to the arc box sides using #10-32 screws. Be sure to replace the asbestos washers, and tighten only till snug to avoid cracking the arc shields.
- 2) Lay the right hand arc chute side on a flat surface with the three long through bolts pointing up in the air. Place the insulating tube on the bolt nearest the blowout coil.
- 3) Attach the arc horns to the molded arc horn insulators using two #10-32 x 3/8 binding head screws.
- 4) Lay the line arc horn and insulator sub-assembly in place on the right hand arc chute side and bolt the arc horn insulator to the arc chute flange using a #10-32 screw. Check that the insulating panel is behind the arc horn mounting screws.
- 5) Lay the grid stack, grid stack clomp, and load arc horn sub-assemblies in place with the long 1/4-20 bolts passing through the hole in the arc horn knife blade and through the indentation in the grid stack clamp.
- 6) Lay the left hand arc chute side in place and bolt the two arc chute sides together at their flanges, tightening the 1/4-20 hardware finger tight, the steel arc chute hook is held on by one of these bolts. Fasten the left hand cover to the line arc horn insulation, using 10-32 hardware. Tighten the 1/4-20 flange hardware. *DO NOT* tighten the three long bolts. Place the "Flexloc" nut on the bolt with the insulating tube.
- 7) Push the grid stack down toward the arc shields as far as it will go. Tighten the 1/4-20 screw in the grid stack clamping plate until the load arc horn assembly and grid stack are clamped tightly in place. Now tighten the locking nut on the clamp screw and also the hardware on the two long 1/4-20 bolts without insulating tubes passing through the arc chutes.

- 8) When new arc horns or arc horn jaws are installed they should be lubricated with a thin film of silicone grease or vaseline to reduce sliding friction.
- 9) When fitting the arc chutes to the contactor, be sure that the core bolt washers fit on the outside of the blowout pole pieces. Having fitted the arc chutes, rotate them into the operating position and tighten the blowout core bolts. Finally, rotate the arc chute out of position once or twice and check that the knife switch assemblies operate smoothly, and develop contact pressure.

Following any inspection procedure, or after any maintenance work — BE SURE TO REPLACE THE 4 LARGE PHASE BARRIERS. NEVER ENERGIZE THE CONTACTOR AT LINE POTENTIAL WITHOUT HAVING THESE BARRIERS IN PLACE.

ELECTRICAL INTERLOCKS

Two type L-64 interlocks for general use in the control circuit are mounted on a steel bracket which is in turn bolted to the right hand contactor end plate, in front of the magnet. It is very important to be sure the interlock plunger does not reach its solid stop before the contactor is fully closed. The interlock adjustment is properly set when the plunger can be depressed slightly beyond the position it takes when the magnet

armature is fully sealed. This adjustment is made by positioning of the operating screws mounted on the interlock operating lever.

A third type L-64 interlock which is used to insert a protective resistor in the magnet coil circuit is mounted in front of the magnet and is operated directly by the magnet armature. In this application a "late break" operation is required so the interlock is permanently mounted in a position such that its contacts will open when the armature gap "X" of Figure ③ is approximately 3/16".

For further details of the L-64 interlock see I.L. 15-829-7.

PROTECTIVE RESISTOR

The nominal voltage rating of the magnet coil is the D-C voltage which must be applied to the coil to close the main contacts. When the armature picks up, a protective resistor is inserted in series with the coil to reduce the coil voltage to a value which the coil can withstand continuously. The holding voltage applied to the coil should be approximately 25% of nominal rating when the coil is cold and approximately 30% of nominal coil voltage when the coil is hot.

RENEWAL PARTS

The following parts are most subject to wear in ordinary operation*

Name of Part	Identification No.	Number Per Contactor	
		Two Pole	Three Pole
Stationary Contact	316B948G02	4	6
Moving Contact	316B948G02	4	6
Moving Contact Spring	221A498H04	2	3
Moving Contact Shunt	650C130G01	2	3
Arc Box Complete - LF25H230	2018A14G10	2	3
Arc Box Complete - LF50H230	2018A15G10	2	3

*For Complete Parts List refer to RPD16200A2

