

Instructions For L-56 Electrical Interlock For A/200 Series Contactors and Starters



I. L. 13134A

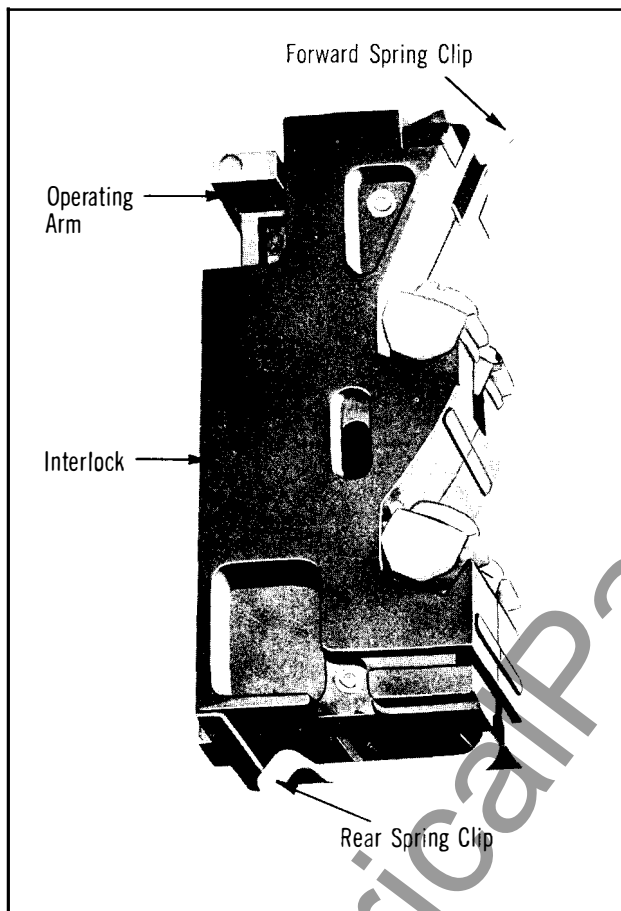

Figure 1 - L-56 Electrical Interlock

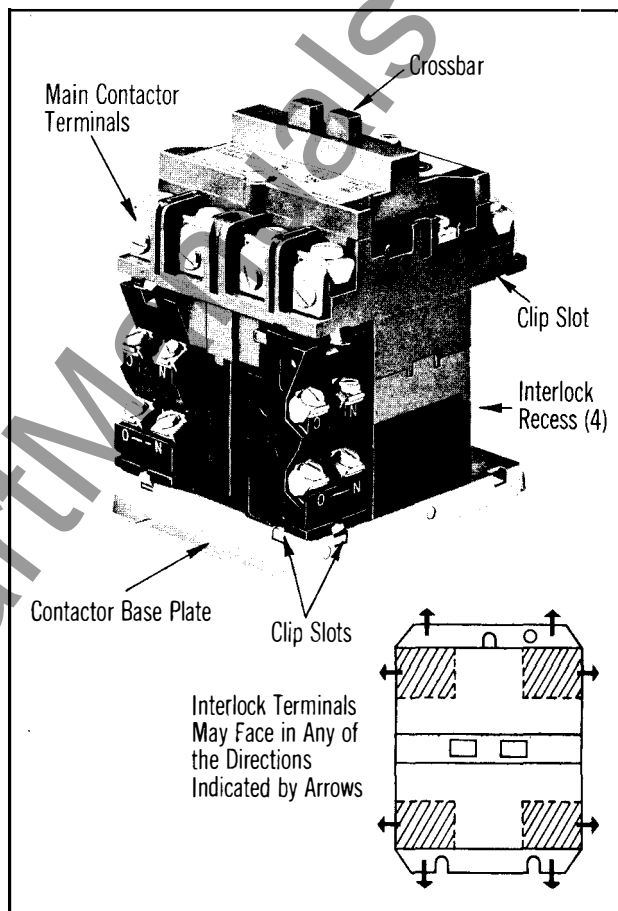

Figure 2 - Interlock Mounting Locations on A/200 Series, NEMA Size 1 Contactor

The L-56 Electrical Interlocks, with NO and NC terminal selection, are designed to be used as auxiliary contact blocks for the Westinghouse A/200 series of contactors and starters. The L-56 is a riveted unit and no service and replacement parts are required, nor should any oil or lubricants be used on any part of the interlock. The double break silver alloy contacts require no dressing.

The L-56 interlock is held in position by two attached spring clips, so no mounting hardware or tools are required.

Installation

A maximum of four L-56 interlocks can be mounted on each contactor, in recesses below the main contactor terminals at the corners of the base plate, facing any of the directions shown in Figure 2.

1. De-energize contactor and insure that all electrical power is off.

Referring to Figure 2 . . .

2. Select the position desired for mounting the interlock. Prepare to insert

the interlock with the wiring terminals facing away from the contactor base plate and the front of the interlock squared-up with the side of the contactor.

3. With the spring clips of the interlock aligned with the clip slots, slide the interlock into the recess allowing both spring clips to lock into their slots. The interlock will then be flush against the rear of the recess.

4. Check engagement of crossbar with operating arm by depressing crossbar man-

ually to insure simultaneous movement of L-56 operating arm.

5. Internal wiring shown in Figure 3.

Removal

The interlock may be removed from the contactor by depressing the forward spring clip approximately 1/16 inch and pulling the interlock from the contactor recess.

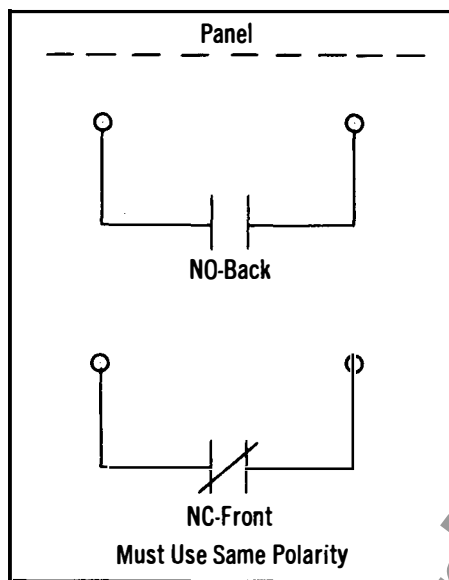

TABLE 1—RATINGS—L-56 ELECTRICAL INTERLOCK			
SWITCHING RATINGS			
Load	Voltage	Current (Amperes)	
		Inrush	Normal
Inductive, AC	110-125	30	3
	220-250	15	1.5
	440-480	7.5	.75
	550-600	6	.6
DC	115-125		1.1
	230-250		.55
	550-600		.2

Figure 3 - Internal Wiring Diagrams

Ordering Data

One L-56 Electrical Interlock-Universal Poles-S# 503C782G01
 1-NO and 1-NC contact.