

TOSHIBA

575 Volt Rating

OPERATION MANUAL

S5

July, 1999
Part #49916-001



**VARIABLE TORQUE
ADJUSTABLE SPEED DRIVE**

www.ElectricalPartManuals.com

IMPORTANT NOTICE

The instructions contained in this manual are not intended to cover all of the details or variations in equipment, nor to provide for all possible issues concerning the installation, operation, or maintenance of this equipment. Should additional information be desired or should particular problems arise which are not covered sufficiently for the purchaser's purposes, the matter should be referred to the local Toshiba sales office.

The contents of this instruction manual shall not become a part of or modify any prior or existing agreement, commitment, or relationship. The sales contract contains the entire obligation of Toshiba International Corporation's Adjustable Speed Drive Division. The warranty contained in the contract between the parties is the sole warranty of Toshiba International Corporation's Adjustable Speed Drive Division and any statements contained herein do not create new warranties or modify the existing warranty.

Toshiba International Corporation reserves the right, without prior notice, to update information, make product changes, or to discontinue any product and/or service identified in this publication.

Any electrical or mechanical modifications to this equipment, without prior written consent of Toshiba International Corporation, will void all warranties and may void UL/CUL listing. Unauthorized modifications also can result in personal injury, death, or destruction of the equipment.

AC ADJUSTABLE SPEED DRIVE

Please complete the Extended Warranty Card supplied with this drive and return it by prepaid mail to Toshiba. This activates the extended warranty. If additional information or technical assistance is required please contact your local distributor or call Toshiba's ASD marketing department toll free at (800) 231-1412 or write to: Toshiba International Corporation, 13131 W. Little York Road, Houston, TX 77041-9990.

Please complete the following information for your records and to remain within this equipment manual:

Drive Model Number: _____

Drive Serial Number: _____

Date of Installation: _____

Inspected By: _____

Name of Application: _____

INTRODUCTION

Thank you for purchasing the 575 Volt VFS5 series adjustable speed drive. This adjustable frequency solid-state digital AC drive features vector operation control mode, energy saving mode, built-in speed control potentiometer and a four character 7-segment type LED display with five other discrete LED indicators. This drive is designed for an external braking resistor and DC link reactor. These features, combined with RS232 communication link, make it suitable for a wide variety of applications that require unparalleled motor control and reliability.

It is the intent of this operation manual to provide a guide for **safely** installing, operating, and maintaining the drive. This operation manual contains a section of general safety instructions and is marked throughout with warning symbols. **Read this operation manual** thoroughly before installing and operating this electrical equipment.

All safety warnings must be followed to ensure personal safety.

Follow all precautions to attain proper equipment performance and longevity.

We hope that you find this operation manual informative and easy to use. For assistance with your drive, information on our free drive application school, or information on Toshiba's complete line of **motors, adjustable speed drives, switchgear, instrumentation, uninterruptible power supplies, PLCs, and motor control products**, please call toll free (800) 231-1412 or write to our plant at: Toshiba International Corporation, 13131 W. Little York Road, Houston, TX 77041-9990.

Again, thank you for your purchase of this product.

GENERAL SAFETY INSTRUCTIONS

Warnings in this manual appear in either of two ways:

- 1) *Danger warnings* - The danger warning symbol is an exclamation mark enclosed in a triangle which precedes the 3/16" high letters spelling the word "DANGER". The Danger warning symbol is used to indicate situations, locations, and conditions that can cause serious injury or death:



- 2) *Caution warnings* - The caution warning symbol is an exclamation mark enclosed in a triangle which precedes the 3/16" high letters spelling the word "CAUTION". The Caution warning symbol is used to indicate situations and conditions that can cause operator injury and/or equipment damage:



Other warning symbols may appear along with the *Danger* and *Caution* symbol and are used to specify special hazards. These warnings describe particular areas where special care and/or procedures are required in order to prevent serious injury and possible death:

- 1) *Electrical warnings* - The electrical warning symbol is a lightning bolt mark enclosed in a triangle. The Electrical warning symbol is used to indicate high voltage locations and conditions that may cause serious injury or death if the proper precautions are not observed:



- 2) *Explosion warnings* - The explosion warning symbol is an explosion mark enclosed in a triangle. The Explosion warning symbol is used to indicate locations and conditions where molten, exploding parts may cause serious injury or death if the proper precautions are not observed:



For the purpose of this manual and product labels, a **Qualified Person** is one who is familiar with the installation, construction, operation and maintenance of the equipment and the hazards involved (see 1996 NEC (National Electric Code) Article 100 - Definitions).

This person must:

- 1) Carefully read the entire operation manual (see 1996 NEC Article 110-3 "Installation and Use").
- 2) Be trained and authorized to safely energize, de-energize, clear faults, ground, lockout and tag circuits and equipment in accordance with established safety practices.
- 3) Be trained in the proper care and use of protective equipment such as safety shoes, rubber gloves, hard hats, safety glasses, face shields, flash clothing, etc. in accordance with established safety practices.
- 4) Be trained in rendering first aid.

CONTENTS

	<u>PAGE</u>
Disclaimer	3
Introduction	4
General Safety Instructions	5
Contents	6 - 7
Inspection/Storage/Disposal	
Inspection of the New Drive	8
Storage	8
Disposal	8
Inspection and Precautions	
Installation Safety Precautions	9
Operating Safety Precautions	11
Confirmation of Wiring	12
Start-up and Test	12
Maintenance	12
Operating Specifications	
575 Volt NEMA Type 1 Chassis Ratings	13
Standard Specifications	14
Equipment Wiring	
Selection of Main Circuit Wiring Equipment and Standard Cable Sizes	16
Grounding	17
Motor Selection	17
Standard Power Connection Diagrams	18
Standard Power Terminal Functions	19
Typical Control Wiring Connection Diagrams	20
Standard Control Terminal Connections and Functions	22
Operating Panel	
Operating Panel Layout	24
Operating Panel Modes	25
Operating Panel Usage	25
7-Segment Alphanumerics	26
Parameter Setting	27
Key Operations	28

CONTENTS (cont'd)

	<u>PAGE</u>
Settings	
Setting The Acceleration and Deceleration Time	29
Increasing Torque	29
Setting The Environmental Functions	30
Setting The Starting and Stopping Methods	32
Setting The Frequency Command Method	32
Connecting and Calibrating Meters	33
Resetting to Default Values	34
Setting the Motor Protection Characteristics	34
Setting The Extended Parameters	35
Searching For Parameters Different From Default Values	35
 Parameter List (Basic and Extended)	
Basic Parameters (Group No. 00)	36
Extended I/O Parameter (Group No. 01)	37
Extended Frequency Parameter (Group No. 02)	37
Extended Operating Mode Parameter (Group No. 03)	38
Extended Torque Parameter (Group No. 04)	38
Extended Accel & Decel Time Parameter (Group No. 05)	38
Extended Protection Parameter (Group No. 06)	39
Extended Panel Parameter (Group No. 07)	39
Extended Communication Parameter (Group No. 08)	39
 Operations	
Operation with Built-in Potentiometer and RUN /STOP Keys	40
Operation with Built-in Potentiometer and External Start Signal	41
Setting Frequency Using External Signal	42
Setting Frequency Using Two External Signals	43
Selecting a Preset Speed Frequency and Using External Start Signals ...	44
Monitoring Operating Conditions	45
 Protective Functions	
Trips and Countermeasures	46
Resetting Errors When Trip is Activated	47
 Dimensions and Weights	
Dimensions for VFS5-5020UPH through VFS5-5040UPH	48
Dimensions for VFS5-5060UPH through VFS5-5120UPH	49
Dimensions for VFS5-5160UPH through VFS5-5270UPH	50
 Tables	
Input Terminal Selection Table	51
Output Terminal Selection Table	52
Default Value Table	52

Inspection of the New Drive

Upon receipt, inspect the drive for shipping damage. After uncrating:

- 1) Check the unit for loose, broken, bent or otherwise damaged parts due to shipping.
- 2) Check to see that the rated capacity and the model number specified on the nameplate conform to the order specifications.

Storage

- 1) Store in a well ventilated location and preferably in the original carton if the drive will not be used immediately after purchase.
- 2) Avoid storage in locations with extreme temperatures, high humidity, dust, or metal particles.

Disposal

Please contact your state environmental agency for details on disposal of electrical components and packaging in your particular area. **Never dispose of electrical components by incineration.**

Installation Safety Precautions







CAUTION

- 1)  **Always ground the unit to prevent electrical shock and to help reduce electrical noise. A separate ground cable should be run inside the conduit with the input, output, and control power cables (See Grounding page 17).**
THE METAL OF CONDUIT IS NOT AN ACCEPTABLE GROUND.
- 2) Only qualified personnel should install this equipment (see General Safety Instructions on page 5).
- 3) Installation of drive systems should conform as a minimum, to the 1996 NEC *National Electrical Code* Article 110 "Requirements For Electrical Installations", to all regulations of the *Occupational Safety and Health Administration*, and to any other applicable national, regional or industry codes and standards.
- 4) Install in a secure and upright position in a well ventilated location that is out of direct sunlight. The ambient temperature should be between -10° C and 40° C.
- 5) Allow a clearance space of 4 inches (20 cm) for the top and bottom and 2 inches (5 cm) on both sides. This space will insure adequate ventilation. Do not obstruct any of the ventilation openings.
- 6) Avoid installation in areas where vibration, heat, humidity, dust, fibers, steel particles, explosive mists, gasses or sources of electrical noise are present.
- 7) Adequate working space and illumination must be provided for adjustment, inspection and maintenance of the drive (see 1996 NEC Article 110-16).
- 8) A noncombustible insulating floor or mat should be provided in the area immediately surrounding the electrical system where maintenance is required.
- 9) Use **lockout/tagout** procedures on branch circuit disconnect before drive installation.
- 10) Connect three phase power of the correct voltage to input terminals L1, L2, L3 (R, S, T) and connect 3- phase power from output terminals T1, T2, T3 (U, V, W) to a motor of the correct voltage and type for the application. Size the branch circuit conductors in accordance with *Selection of Main Circuit Wiring Equipment and Standard Cable Sizes* Page 16.
- 11) If conductors of a smaller than recommended size are used in parallel to share current then the conductors should be kept together in sets i.e. U1, V1, W1 in one conduit and U2, V2, W2 in another (see 1996 NEC Article 300-20 and Article 310-4). National and local electrical codes should be checked for possible cable derating factors if more than three power conductors are run in the same conduit (see 1996 NEC Article 310 adjustment factors on page 70-196).
- 12) Install a molded case circuit breaker (MCCB) between the power source and the drive. Size the MCCB to clear the available fault current of the power source (see 1996 NEC Article 430 Article 102 through Article 111).

Installation Safety Precautions (cont'd)**CAUTION**

- 13) Use separate metal conduits for routing the input power, output power, and control circuits.
- 14) If the factory provided door or NEMA 1 enclosure is removed from the drive, then, before operating, it must be provided with an alternate enclosure of NEMA 1 minimum rating.
- 15) Do not connect control circuit terminal block return connections marked CC to inverter earth ground terminals marked GND(E). See *Standard Power Connection Diagrams* on page 18 and *Typical Control Wire Connection Diagrams* on page 20 for locations.
- 16) If a secondary Magnetic Contactor (MC) is used between the inverter output and the load, it should be interlocked so the ST-CC terminals are disconnected before the output contactor is opened. If the output contactor is used for bypass operation, it must also be interlocked so that commercial power is never applied to the inverter output terminals (U,V,W).
- 17) Power factor improvement capacitors or surge absorbers must not be installed on the drive's output.
- 18) For those applications requiring extended ASD to motor cable lengths exceeding the chart recommendation shown on page 17, a output voltage filter should be added.

Operating Safety Precautions

- 1)  **DANGER**  Do not touch any internal part with power applied to the drive; first remove the power supply from the drive and wait until charge LED (see page 24 for location) is no longer illuminated. **Charged capacitors can present a hazard even if source power is removed from the drive.**
- 2)   **DO NOT OPERATE THIS UNIT WITH ITS CABINET DOOR OPEN.**
- 3) **Do not touch the heatsink while unit is in operation.** Serious burns could result.
- 4) **Only properly trained and qualified personnel should be allowed to service or have access to the adjustments and operation of this equipment.** They should be familiar with operating motor drives and with the driven machinery. See page 5.
- 5) **Follow all warnings and precautions and use care not to exceed equipment ratings.**
- 6) **Do not power up the drive before completely reviewing this manual.**
- 7) The input voltage must be within +/-10% of the specified input voltage. Voltages outside of this permissible tolerance range may cause internal protection devices to turn on or can cause damage to the drive. Also, the input frequency should be within +/-2 Hz of the specified input frequency.
- 8) Do not use this drive with a motor whose rated input is greater than the rated drive output.
- 9) Do not apply commercial power to the drive output terminals T1 (U), T2 (V), or T3 (W) even if the source power is off. Disconnect the drive from the motor before applying bypass voltage to the motor.
- 10) Interface problems can occur when this drive is used in conjunction with some types of process controllers. **Signal isolation may be required to prevent controller and/or drive malfunction** (contact Toshiba or the process controller manufacturer for additional information about compatibility and signal isolation).
- 11) Do not open and then re-close a secondary magnetic contactor (MC) between the drive and the load unless the drive is OFF (output frequency has dropped to zero) and the motor is not rotating. **Abrupt re-application of the load while drive is on or while motor is rotating can cause drive damage.**
- 12) Use caution when setting output frequency. **Overspeeding a motor can decrease its torque-developing ability and can result in damage to the motor and/or driven equipment and can result in serious personal injury.**
- 13) Use caution when setting the acceleration and deceleration time. Unnecessarily short times can cause tripping of the drive and mechanical stress to loads.
- 14) If the drive produces smoke, odor or abnormal noises, turn off input power immediately and request service.
- 15) If the drive will be inactive for a long period of time, turn off the input power.

Confirmation of Wiring



Make the following final checks before applying power to the unit:

- 1) Confirm that source power is connected to terminals L1, L2, L3 (R, S, T).
Connection of incoming source power to any other terminals will damage the drive.
- 2) The 3-phase source power should be within the correct voltage and frequency tolerances.
- 3) The motor leads must be connected to terminals T1, T2, T3 (U, V, W).
- 4) Make sure there are no short circuits or inadvertent grounds and tighten any loose connector terminal screws.

Start-Up and Test



Prior to releasing an electrical drive system for regular operation after installation, the system should be given a start-up test by qualified personnel. This assures correct operation of the equipment for reasons of reliable and safe performance. It is important to make arrangements for such a check and that time is allowed for it.

When power is applied for the first time, the drive automatically starts up in the frequency monitor function of standard monitor mode with the 'default' parameters set as shown in the "FACTORY SETTING" column of the parameter tables starting on page 36. If these settings are not optimal for the application, program the desired settings before initiating a run. The drive can be operated with no motor connected. Operation with no motor connected or use with a small trial motor is recommended for initial adjustment or for learning to adjust and operate the drive.

Maintenance



- 1) Use power lockout/tagout procedures on the disconnecting means in accordance with applicable electrical codes (see 1996 NEC Article 430-101) before performing any drive maintenance.
- 2) Periodically check the operating drive for cleanliness.
- 3) Do not use liquid cleaning agents.
- 4) Keep the heatsink free of dust and debris.
- 5)  Periodically check electrical connections for tightness (with power off, locked out, and with charge LED extinguished (see page 24 for location)).

575 Volt NEMA Type 1 Chassis Standard Ratings

VFS5		STANDARD RATINGS						
MODEL	NOTES (see below)	RATED KVA	MOTOR HP(KW)	OUTPUT CURRENT (AMPS)	OUTPUT VOLTAGE	OVERLOAD CURRENT	MAIN CIRCUIT INPUT POWER 3-PHASE	INPUT CONTROL POWER
5020	(1)	1	1/7.5	2.1	575V 3-PHASE MAX VOLTAGE	150% FOR 60 SEC. 100% CONTINUOUS	575V 50/60Hz VOLTAGE +/- 10% FREQ. +/- 2Hz	NO EXTERNAL CONTROL POWER SOURCE REQUIRED
5030	(1)	2	2/1.5	3				
5040	(1)	3	3/2.2	4				
5060	(1)	6	5/3.8	6.1				
5120	(1)	12	10/7.5	12				
5160	(1)	16	15/11	17				
5220	(1)	22	20/15	22				
5270	(1)	27	25/18.5	27				

NOTES:

- 1) NEMA Type1 UL/CUL listing

Standard Specifications

Major Control Specifications	Control System	Sinusoidal PWM control
	Output voltage regulation	Same as power line.
	Output frequency range	0.5 to 320 Hz (0.5 to 80Hz default setting)*. Maximum frequency is adjustable between 30 and 320 Hz.
	Frequency setting resolution	0.1Hz input from the operating panel, 0.2 Hz analog input (@ maximum frequency of 100 Hz).
	Frequency accuracy	Analog setting: $\pm 0.5\%$ of the maximum output frequency or less @ $25^{\circ}\text{C} \pm 10^{\circ}\text{C}$, Digital setting: $\pm 0.01\%$ of the maximum output frequency or less @ -10°C to $+50^{\circ}\text{C}$
	Voltage/frequency characteristics	Constant V/f, variable torque mode, sensorless vector control mode, automatic torque boost mode, base frequency adjustment (25 to 320Hz), and torque boost adjustment (0 to 30%).
	Overload current rating	150%, 60 seconds
	Frequency setting signal	Built-in potentiometer on the front panel, external potentiometer (1k ohm to 10k ohm variable resistor connectable), 0 to 10Vdc (input impedance: $V_{IA} = 30.55k$ ohm, $V_{IB} = 30k$ ohm), 4 to 20mAdc (input impedance = 400 ohm), and optional characteristics (gain, bias) can be preset by 2-point setting
	PI control	Proportional gain, integral gain adjustments.
Operation functions	Start frequency	Adjustable between 0 and 10Hz
	Frequency jump	Three points (by setting jump frequencies and band widths)
	PWM carrier frequency	Adjustable between 2.2 and 12kHz (default = 12kHz)
	Accel/decel time	0.1 to 3600 secs, accel/decel time 1 or 2 selectable, S1 and S2 accel/decel pattern selectable
	Jogging run	Jog run from panel with JOG mode selection. Terminal block operation possible with parameter settings (see page 37).
	Preset speed operation	Set frequency +15 preset speeds possible with open/closed combinations of SS1, SS2, SS3, SS4 and CC
	Retry operation	A maximum of ten automatic retries are selectable (see page 38) Retry will occur immediately after a self evaluation of the main circuit is completed.
	Braking	Externally connected braking resistor (optional)
	DC braking	Braking start frequency (0 to max frequency), braking level (0 to 100%), braking time (0 to 20 seconds).
	Output voltage regulation	Drive can be programmed to set the maximum output voltage, float with the input voltage, or set the maximum output voltage to the voltage sensed at power-up.
	Input terminal functions	Forward and reverse input signals, preset speed select input signals, reset input signals, and etc (see page 37).
	Output terminal functions	Low-speed detection output signals, speed reached output signals, and etc.
	Faultsignal	1c contact output (250 Vac, 30 Vdc - 2A resistive load, 250 Vac, 30 Vdc - 1.5A inductive load, $\cos\phi = 0.4$)
	Output for frequency counter or ammeter	Analog output (1 mA dc full scale ammeter or 7.5 Vdc, 1mA full scale DC ammeter or rectifying AC voltmeter, 225% current max., 1mA DC, 7.5 Vdc full scale)(see page 33)

Standard Specifications (cont'd)

Display	Keypad Interface	4-digit, 7-segment LEDs w/8 discrete indicator lamps.
Inverter/Motor	Protective functions	Stall prevention, current limit, overcurrent, overvoltage, output short-circuit, overvoltage limit, undervoltage, electronic thermal overload protection, armature overcurrent during starting, overcurrent on load-side when starting-up, and emergency stop (selection)
	Protection from instantaneous power failure	Auto-restart and regeneration power ride-through control
	Electronic thermal characteristics	Standard motor and constant torque VF motor selectable; overload trip and overload stall selectable
Enclosure	Type	NEMA Type 1
	Cooling method	Forced air cooling
	Service environment	Indoor. Altitude of < 1000m
		Must not be exposed to direct sunlight, corrosive and/or explosive gases or mists, fibers and dusts.
	Ambient temperature	From -10°C to 40°C (14°F to 104°F).
	Relative humidity	93% maximum (non-condensating)
	Vibration	5.9 m/s (0.6G) maximum (10 to 55Hz)
	Climatic class	3K3
	Polution degree	2
IP rating	2X	

Selection of Main Circuit Wiring Equipment and Standard Cable Sizes

Drive	* Molded case circuit breaker (MCCB)	Ampacity (FLA x 1.25)	** Typical cable size (AWG)		
Model Number	Amp rating (A)	(A)	Main power and motor load	Frequency command input, frequency meter, ammeter	Other signal circuits
S5-5020	15	3	#14	3-core shield cable (speed reference) 2-core shield cable #20	#18
S5-5030	15	4	#14		
S5-5040	15	5	#14		
S5-5060	15	8	#14		
S5-5120	30	15	#14		
S5-5160	35	22	#12		
S5-5220	50	28	#10		
S5-5270	60	34	#10		

* A customer supplied disconnect means must be provided in the motor branch circuit which supplies power to the drive. It can be separate for use with customer supplied fuses or it can be an integral part of a customer supplied 3-pole circuit breaker (see 1996 NEC Article 430-103 through 430-113). All drives in this series are rated for output short circuit fault currents of 200,000A. The selection of MCCB (molded case circuit breaker) for this table is in accordance with 1996 NEC Article 430-51, 430-52, 430-152, and 240-6.

** Wire sizing is based upon NEC table 310-16 or CEC Table 2 using 75 deg C cable, an ambient of 30 deg C, cable runs for less than 300 FT., and copper wiring for not more than three conductors in raceway or cable or earth (directly buried). The customer should consult the NEC or CEC wire Tables for his own particular application and wire sizing.

*** Use two parallel conductors instead of a single conductor (this will allow for the proper wire bending radius within the cabinet). Use separate conduits for routing parallel conductors. This prevents the need for conductor derating (see note 3 page 17).



CAUTION

Turn off power to the drive before making any wiring changes to the analog output circuits.



CAUTION

Use separate conduits for routing incoming power, power to motor, and control conductors. Use no more than three power conductors and a ground conductor per conduit.

See next page for notes.

Selection of Main Circuit Wiring Equipment and Standard Cable Sizes (cont'd)

Notes:

- 1.) Contacts used to connect drive terminals should be capable of switching low current signals (i.e. 5 mA).
- 2.) The drive has internal motor overload protection which has been functionally certified by Underwriters Laboratories Inc. and no additional external motor overload protection is required when used to drive a single motor load (see 1996 NEC Article 430-32 and 430-39).
- 3.) When wiring with parallel conductors, the conductors should be kept together in phase sets to avoid heating the surrounding metal by induction. Install U1, V1, W1 conductors in one conduit and parallel conductors U2, V2, W2 in another conduit. The ground conductor must be run in the same conduit. See 1996 NEC Article 300-20(a), 310-4, 310-5. Size the grounding conductor in accordance with 1996 NEC Table 250-95.
- 4) Twisted pair wires should be used for external meters connected to AM and FM terminals.
- 5) For multiple motor applications, a thermal-magnetic circuit breaker must be installed between the drive and each motor (even though the drive has built-in overload protection). The thermal circuit is for overload sensing and the magnetic coil is for abnormal conditions such as short circuits. Select the MCCB (molded case circuit breaker) in accordance with 1996 NEC Article 430-51 through 430-53, 430-152, and 240-6.

Grounding

The drive must be grounded in accordance with Article 250 of the National Electrical Code or Section 10 of the Canadian Electrical Code, Part I and the grounding conductor should be sized in accordance with 1996 NEC Table 250-95 or CEC, Part I Table 16. See Installation Safety Precautions notes 7 and 14.



CAUTION Conduit is not a suitable ground for the inverter.

Motor Selection

- 1) Exceeding the peak voltage rating or the rise time allowable of the motor insulation system will reduce the life expectancy. To insure good motor insulation life, consult with the motor supplier to determine motor insulation ratings and allowable maximum output lead distance. Long lead lengths between the motor and the drive may require filters to be added to the drive output.

Suggested Maximum¹ Output Lead Distance

AC Motor Voltage	PWM Carrier Frequency	NEMA MG-1-1998 Section IV Part 31 Compliant Motors ²
575 V	< = 5 kHz	200 ft.
	> 5 kHz	100 ft.

¹ For lead lengths that exceed suggested maximum contact your local distributor or Toshiba for additional application assistance.

² Toshiba EQP III, III-XS & EQP III-841 motors incorporate an insulation system that is in compliance with NEMA MG-1-1998 Section IV Part 31.

- 2) Bearing Considerations:
Motors operating from adjustable speed drive power sources tend to operate at higher temperatures which may increase the need for more frequent lubrication cycles.

Standard Power Connection Diagrams

VFS5-5020UPH through VFS5-5040UPH

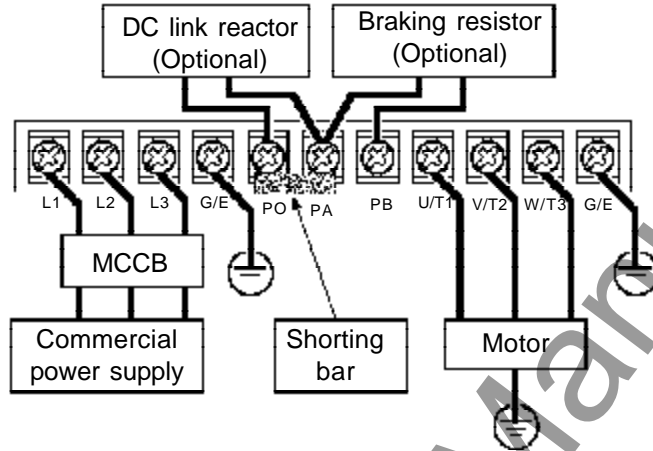

VFS5-5060UPH through VFS5-5120UPH

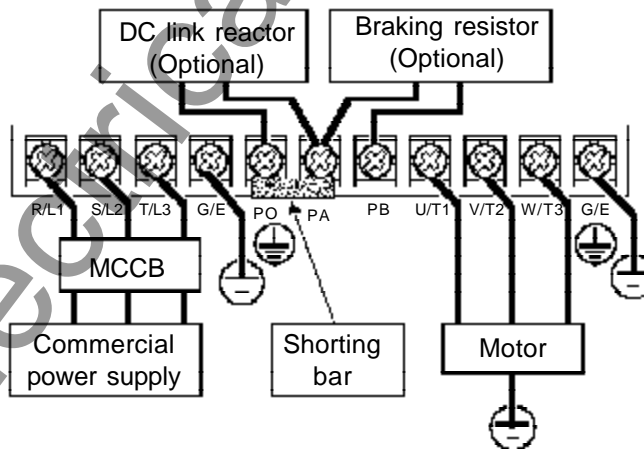

Standard Power Connection Diagrams (cont'd)

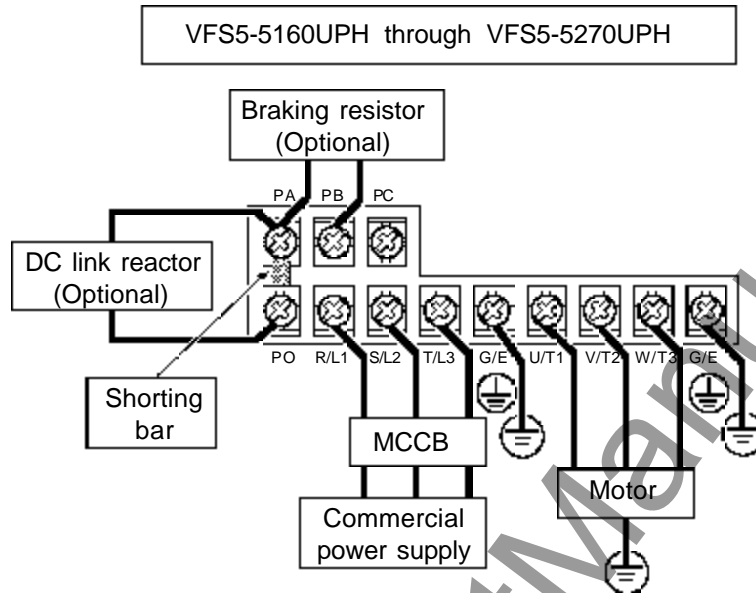

Standard Power Terminal Functions

Terminal name	Terminal functions	Terminal location
L1, L2, L3 (R, S, T)	Line input supply terminals for models S5-5020 to S5-5270: Connect to 3 ϕ , 50 or 60Hz, 200 to 545 to 605VAC. Drives can be operated on single phase power when appropriately derated; contact Toshiba distributor for information.	Terminal block or bus bar 
T1, T2, T3 (U, V, W)	Motor output terminals. Connect these terminals to a 3-phase induction motor of the proper voltage, current, and horsepower.	
PA, PB	Braking resistor output terminals. Connect to an external dynamic braking resistor (DBR).	
PA, PO	DC link reactor output terminals. Connect to an external inductor.	
G/E (2-terminals)	This is the earth ground terminal (ground incoming power and outgoing motor load).	

Typical Control Wiring Connection Diagrams

Frequency setting: Built-in potentiometer

Start and stop: External signals

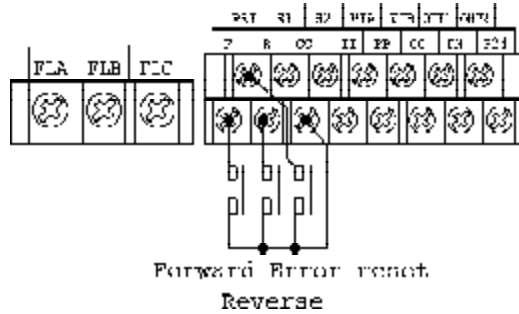

Frequency setting: External signal (0 to 10V voltage signal)

Start and stop: External signals

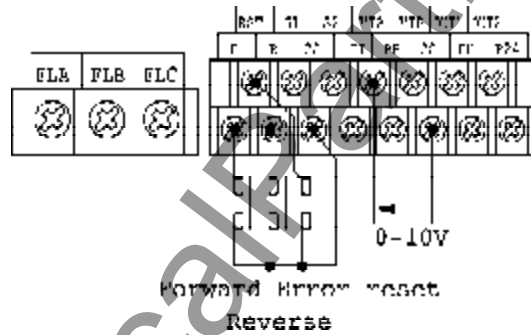

Remote/local operation selection

Frequency setting: External signal (0 to 10V voltage signal or 4 to 20 mA current signal)

Start and stop: External signals

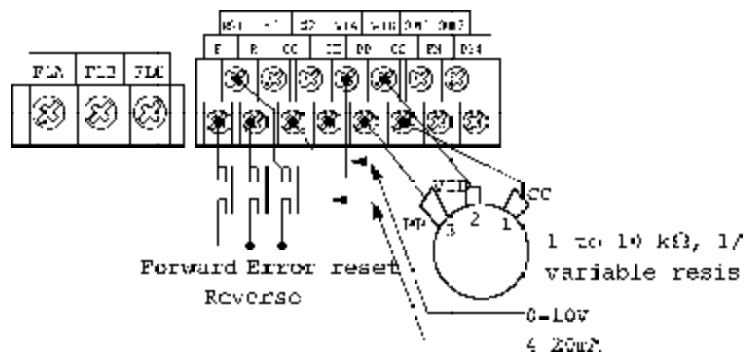

Typical Control Wiring Connection Diagrams (cont'd)

Frequency setting: External potentiometer

Start and stop: External signals

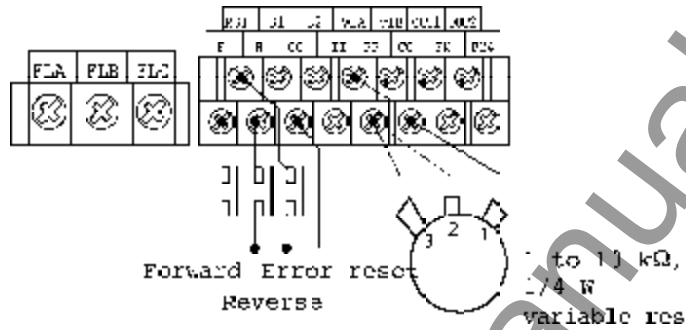

Frequency setting: External signal (4 to 20mA current signal)

Start and stop: External signals

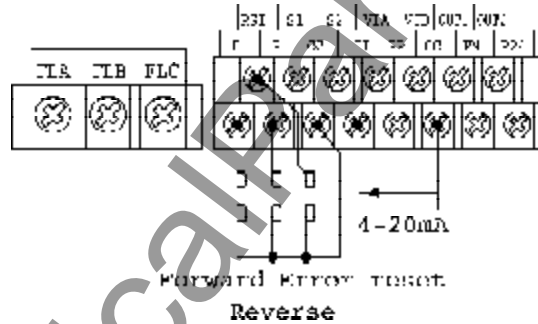

Frequency setting: Three preset speed selection

Start and stop: External signals

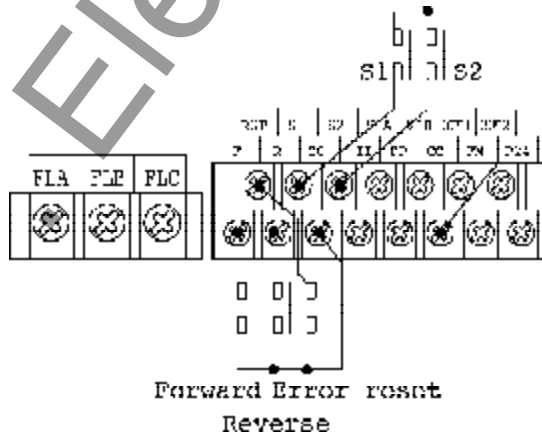

Preset speed selection chart				
S1	OFF	S2	OFF	
S1	ON	S2	OFF	Speed 1
S1	OFF	S2	ON	Speed 2
S1	ON	S2	ON	Speed 3

Standard Control Terminal Connections and Functions

Terminal block name	I/O	Function	Electric rating	Inverter internal circuit
F	I	Motor rotates clockwise when the F terminal is connected to the CC terminal.	24 Vdc, 10 mA dry contact input	<p>Typical Input Circuit for F, R, S1, S2, RST</p>
R	I	Motor rotates counterclockwise when the R terminal is connected to the CC terminal. Motor rotates counterclockwise when F and R terminals are connected simultaneously with the CC terminal.	24 Vdc, 10 mA dry contact input	
S1	I	Control input signal. Factory set, select preset speed operation when the S1 terminal is connected with the CC terminal.	24 Vdc, 10 mA dry contact input	
S2	I	Control input signal. Factory set, select preset speed operation when the S2 terminal is connected with the CC terminal.	24 Vdc, 10 mA non-voltage contact input	
RST	I	Error output signal is reset when the RST terminal is connected with the CC terminal.		
CC	Common	Control common signal (not connected to the fault output). Both CC terminals are internally connected.		
FM	O	Analog meter output frequency or output current can be measured. Output frequency is factory set.	1 mA full scale DC ammeter or 7.5 Vdc, 1mA DC voltmeter	
OUT1	O	Control output signal. The low speed signal is selected by default. (Connects to the CC terminal when the operation frequency exceeds the F100 frequency.)	24 Vdc, 50 mA open collector output maximum	
OUT2	O	Control output signal. The speed-reached signal is selected by default. (Connects to the CC terminal when the operation frequency reaches F101 frequency).	24 Vdc, 50 mA open collector output maximum	

Standard Control Terminal Connections and Functions (cont'd)

Terminal block name	I/O	Function	Electric rating	Inverter internal circuit
CC	Common	Control common signal (not connected to the fault output). Both CC terminals are connected together.		
II	I	Frequency reference (4-20mA). Used to set output frequency via a 4-20mA current signal supplied from the user's controller. Cannot be used with the VIA signal.	4 to 20 mA (Input impedance: 400 ohm)	
VIA	I	Frequency reference (0-10V). Used to set output frequency via a 0-10V voltage signal supplied from the user's controller. Cannot be used with the II signal.	0 to 10 V (Input impedance: 35.55 kohm)	
VIB	I	Frequency reference (0-10V). Used to set output frequency via a 0-10V voltage signal supplied from the user's controller.	0 to 10 V (Input impedance: 30 kohm)	
PP	O	Power supply for the external potentiometer	10 Vdc, (Connectable potentiometer: 1k to 10k ohm, 1/4 W).	
P24	O	Power supply for the external relay	24 Vdc, 100 mA	
FLA	O	Fault output. Connected with the FLC terminal if a fault occurs (normally open).	250 Vac, 2 A	
FLB	O	Fault output. Connected with the FLC terminal in the normal condition (normally closed).	30 Vdc, 2 A resistive load	
FLC	O	Fault latch output. A common terminal for FLA and FLB.	30 Vdc, 1.5 A inductive load	

Operating Panel Layout

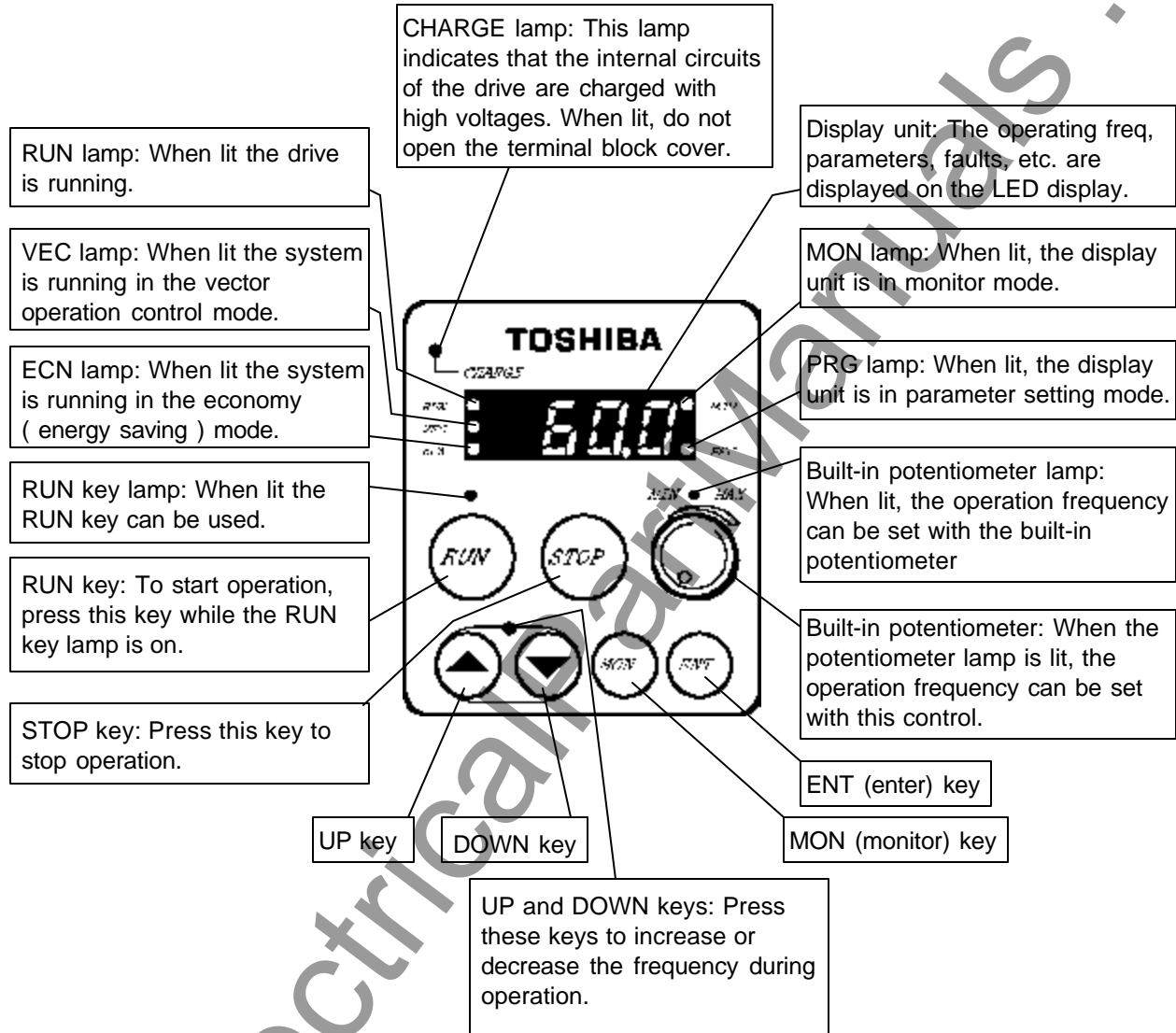





Operating Panel Modes

The following conditions are displayed on the operation panel.

- 1) Frequency, 2) parameter display or changes, and 3) drive condition during operation or in case of an error.

Keys

-  : Selects 1), 2) and 3) in this order. Pressing the MON key displays the first item of the following mode. In the parameter display or change mode, "AU1" is displayed. In the drive condition display mode, "Fr-F" or "Fr-r" is displayed.
-  : Selects the displayed item or stores it in the drive.
-  : Displays the next item or increases a numeric value.
-  : Displays the previous item or decreases a numeric value.

Display Unit

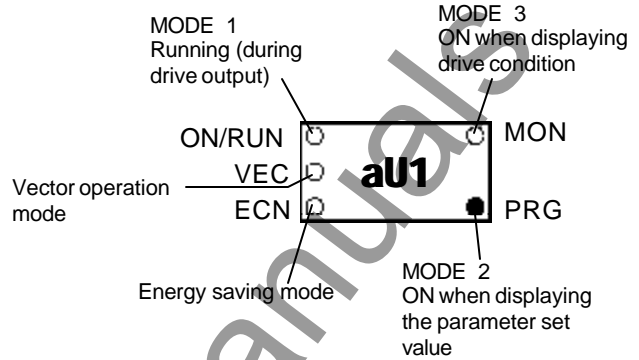

Mode 1): The output frequency is displayed, or fault contents are displayed if the unit is faulted.

Mode 2): A parameter name or parameter set value is displayed.

Mode 3): The drive condition is displayed.

Operating Panel Usage

Parameter display/setting

Drive condition display

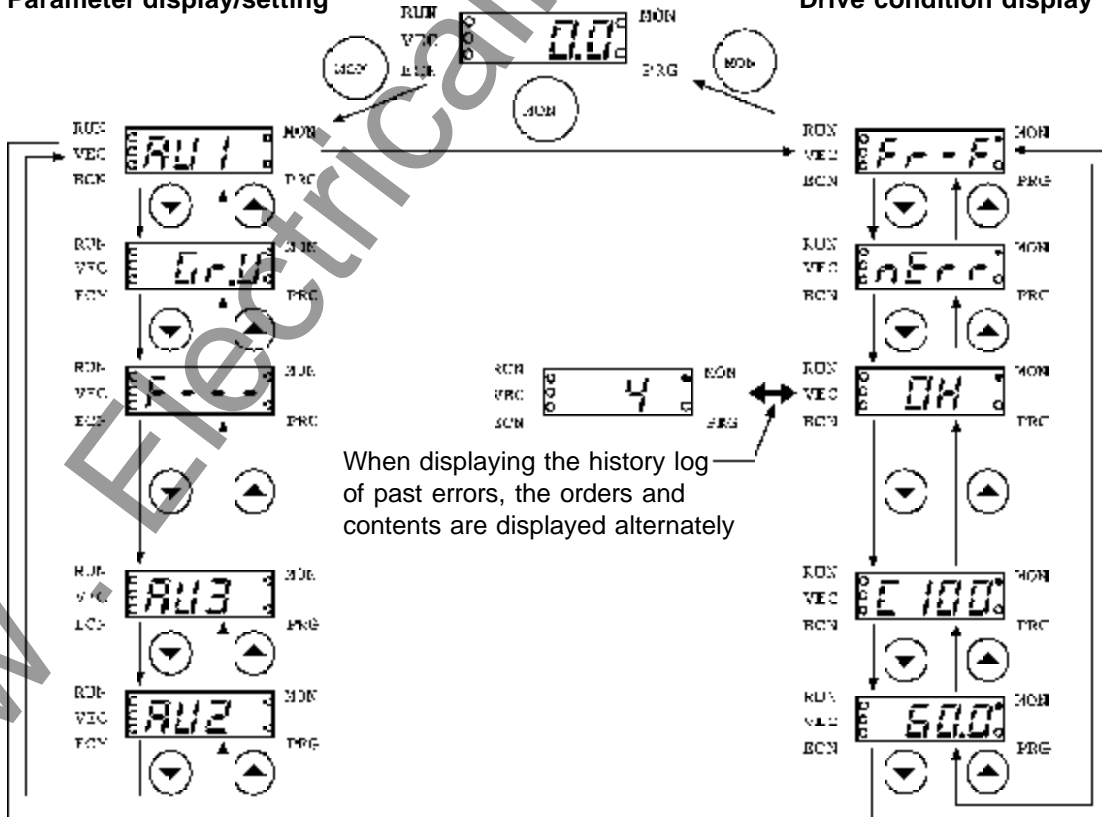

7-Segment Alphanumerics

The 7 segment LED display has a limited number of output characters, therefore the following figures and letters will be used for the display:

Numerics	LED display
0	0
1	1
2	2
3	3
4	4
5	5
6	6
7	7
8	8
9	9
-	-

Characters	LED display
A,a	A
B,b	b
C,c	C
D,d	d
E,e	E
F,f	F
G,g	G
H	H
h	h
I,i	I
J,j	J
L,l	L
M,m	M
N,n	n
O	O
o	o
P,p	P
Q,q	q
R,r	r
S,s	S
T,t	t
U,u	U
V,v	v
Y,y	y

Parameter Setting

There are three parameter groups as shown below:

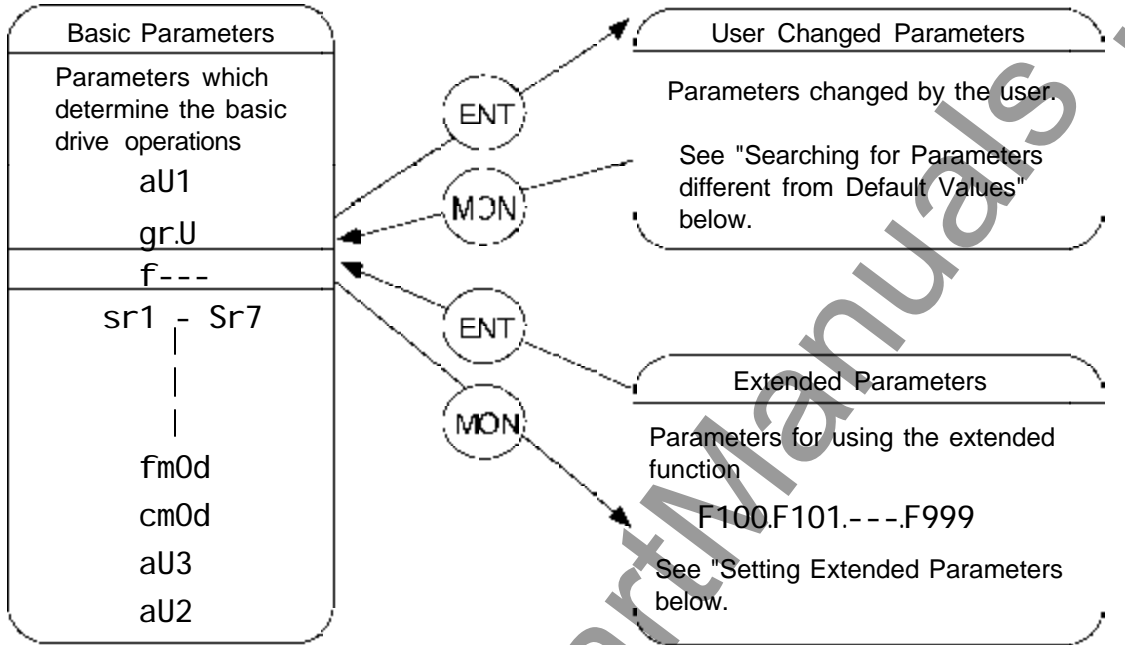

- Notes:**
- 1) If you become confused during operation, press the MON key several times to return to the frequency display.
 - 2) The VFS5 drive has three convenient automatic operation functions (automatic acceleration and deceleration, automatic torque boost, and automatic environment setting). In the following operation, parameters do not need to be set. (These functions may not work properly for some load conditions.)

Acceleration and deceleration time: Automatic

Torque boost: Automatic torque boost or vector operation control

Quick Setup: Motor base/maximum frequency 50/60 Hz selection

- 3) There are some parameters that cannot be changed while running. See the parameter list.

Key Operations

Example of parameter selection with UP and DOWN keys

Example of Parameter Selection with UP and DOWN Keys

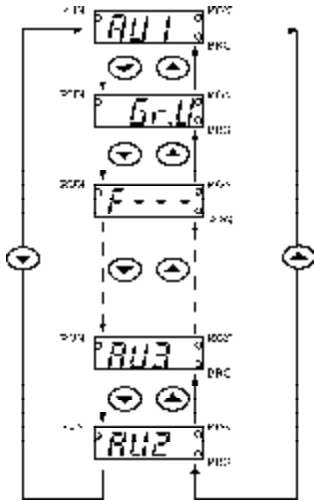

Checking Parameter Set Values

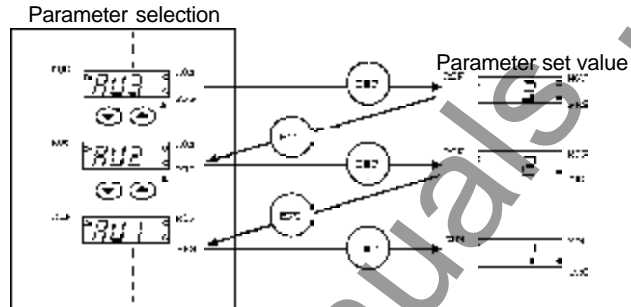

Changing a Parameter

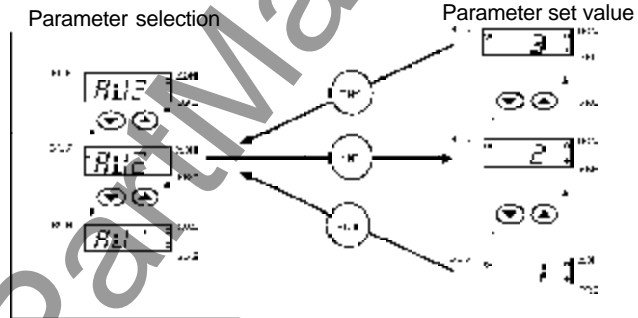

CAUTION

Parameter settings are accepted and fed back to the motor operation even while the motor is running. **When you change the parameter settings during operation, pay attention to how the motor is running.**

- 1) Turn on the power.
- 2) Press the MON key until AU1 is displayed on the display unit.
- 3) Select the desired parameter name from the parameter list starting on page 36. Press the UP or DOWN key until the parameter name is displayed.
- 4) When the desired parameter name is displayed, press the ENT key. The parameter set value is displayed.
- 5) To change the parameter set value, press the UP or DOWN key.
- 6) To store the displayed parameter set value in the drive, press the ENT key. The parameter name and changed set value are displayed alternately, then the parameter name is displayed.
- 7) To set another parameter, repeat step (3).
- 8) To finish parameter setting, press the MON key twice. The current frequency is displayed.



(3) (5)

(4) (6)

(2) (8)

Setting The Acceleration and Deceleration Time

Applicable parameters: Automatic acceleration and deceleration AU1, acceleration time by the drive, and manual setting.

There are two methods of setting the acceleration and deceleration time: Automatic setting of the acceleration and deceleration time by the drive, and manual setting.

- 1) Automatic acceleration and deceleration time setting
To select automatic acceleration and deceleration time setting, set the AU1 value to 1.

Note:

When automatic acceleration and deceleration time setting is selected, the acceleration and deceleration time is always varied according to the load conditions. If the machine requires a predetermined acceleration and deceleration time, use the manual acceleration and deceleration time setting function.

- 2) Manual acceleration and deceleration time setting
Set the AU1 value to 0. Then, set the ACC and dEC values to the desired acceleration time and deceleration time, respectively.

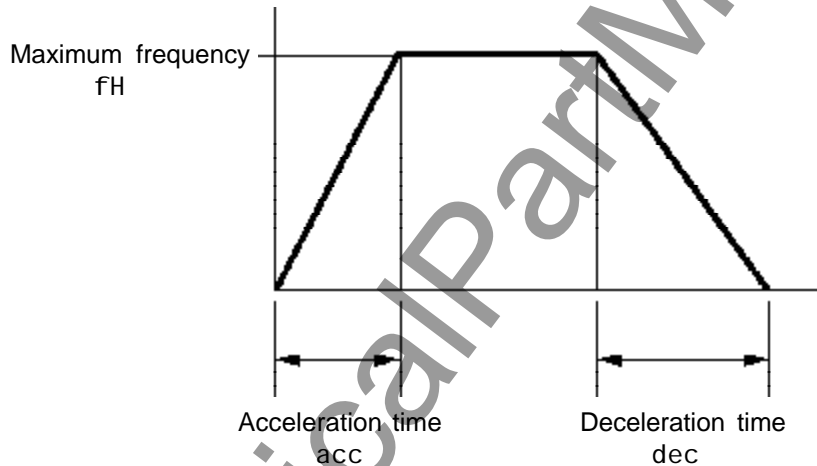

Increasing Torque

Applicable parameters: Automatic torque boost aU2, and torque boost ub.

The motor torque can be increased by raising the inverter output voltage. There are two methods of raising the output voltage: 1) automatic voltage raising by the drive and 2) manual voltage raising.

Note:

If the output voltage is increased too much, the drive may trip overcurrent. This may lead to drive and/or motor damage.

- 1) Automatic torque boost and improving the speed accuracy:
Set the AU2 value to 1. The torque is automatically increased. To increase the speed accuracy, set the AU2 value to 3. If operation is not stable when AU2 is set to 2 or 3, set aU2 to 1, and the operation will become stable.
- 2) Increasing drive output manually:
Set the AU2 value to 0 and increase the ub value. Start with a value of 3 and increment by units of one. Check for low current and smooth operation at each setting and select the best value.

Setting the Environmental Functions (Maximum Frequency, Upper and Lower Limits, Base Frequency, Etc.

*Applicable parameters: Automatic environment setting **AU3**, upper limit frequency **UL**, maximum frequency **FH**, lower limit frequency **LL**, and base frequency **uL**, (VIA/II input point 2 frequency **F204**, auto-restart **F301**, regeneration power ride-through control **F302**, pattern of acceleration and deceleration **F502**, output voltage adjustment **F306**, power voltage compensation **F307**, and VIB point 2 frequency **F213**)*

The drive has various functions for setting the environment to ensure trouble-free operation. These functions can be selected in two ways, automatic selection by the drive, and manual selection.

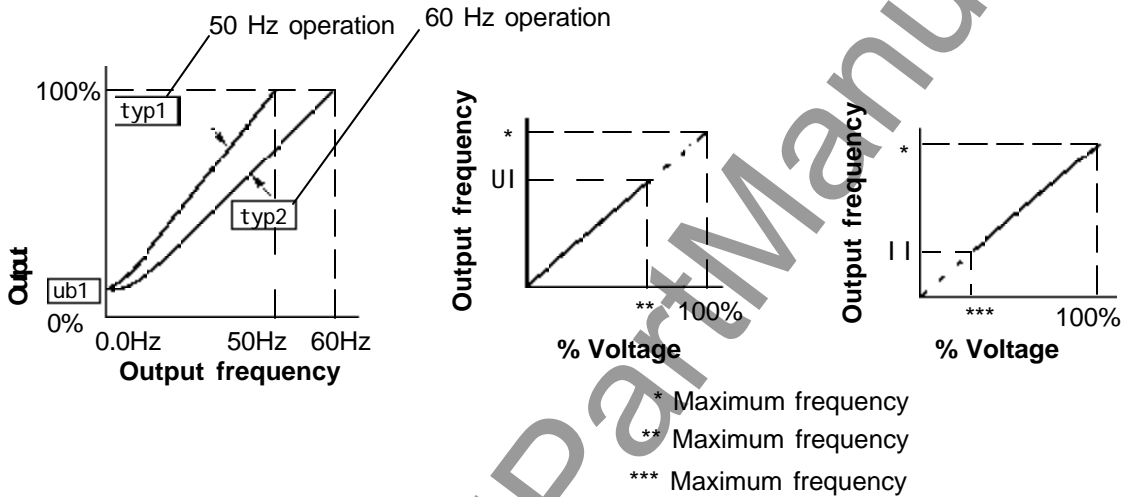

Quick Setup Parameters

The set values differ with the source voltage rating of the motor as shown below:

- 50 Hz motor: Set **AU3** to 1.
- 60 Hz motor: Set **AU3** to 2.



CAUTION

Select a suitable source voltage for the motor. Improper voltage selection could result in rotation failure or, in the worst case, the motor could be damaged.

Notes:

- 1) The 'Quick Setup Function' sets the motor speed lower than the frequency command in case of an instantaneous power failure. If this has an adverse effect on the machine, change it by setting manually.

The automatic environment settings are as shown on page 31.

Setting the Environmental Functions (Maximum Frequency, Upper and Lower Limits, Base Frequency, Etc. (cont'd)

Quick Setup Parameters (cont'd)

Parameter	Description	When AU3 is set to 1	When AU3 is set to 2
Maximum frequency: FH	Maximum output frequency of the drive	50 Hz	60 Hz
Upper limit frequency: UI	Upper limit frequency of the drive	50 Hz	60 Hz
Base frequency: ul	Rated frequency of the motor	50 Hz	60 Hz
Frequency at VIA/II input point 2: f204	Output frequency when a 10 V voltage command is input	50 Hz	60 Hz
Frequency at VIB input point 2: f213	Output frequency when a 10 V voltage command is input	50 Hz	60 Hz
Auto restart: f301	Operation restarts according to the motor speed automatically if F-CC is ON when the power is recovered from instantaneous power failure.	1: Instantaneous power failure restart control is effective	Same as left
Regeneration power ride through control: f302	In case of an instantaneous power failure, the motor speed is reduced automatically to continue operation.	1: Instantaneous power failure non-stop control is effective.	Same as left
Source voltage compensation: f307	Control is performed so that the output voltage does not lower when the source voltage drops.	1: Source voltage compensation is effective.	Same as left
Pattern of acceleration and deceleration: f502	An S pattern is used to accelerate and decelerate the motor speed.	1: S pattern.	Same as left

Manual drive environment setting

Set AU3 to 0, then set the parameters individually.



CAUTION

Do not set the maximum frequency above 80 Hz if the motor is a general-purpose motor not designed for high-speed operation.

Selecting the Starting and Stopping Method

Applicable parameters: Command mode selection *cm0d*

There are two starting and stopping methods as shown below. Select either method.

Starting and stopping method	Set value	Description
Terminal Block	0	The motor starts when the F (forward) or R (reverse) terminal on the terminal block is connected to CC. Acceleration and deceleration is performed at the programmed rate shown in the Basic Parameters on page 36.
RUN / STOP keys	1	When the RUN key on the panel is pressed, the motor is accelerated according to the acceleration pattern. When the STOP key is pressed, the motor is decelerated according to the deceleration pattern.

Setting the Frequency Command Method

Applicable parameters: Frequency setting mode selection *fm0d*

There are three methods of setting the frequency. Select a suitable method.

Frequency setting method	Set value	Description
Terminal block 0-10V, 4-20mA External potentiometer	0	A frequency setting input to VIA, VIB or II on the terminal block is used.
UP / DOWN keys	1	The frequency set with the 'up' or 'down' key on the panel is used. The UP/DOWN key lamp is on when this function is enabled.
Built-in potentiometer	2	The value set with the built-in potentiometer is used. The built-in potentiometer lamp is on when this function is enabled.

Use the parameter F200 to specify the order of priority of two frequency commands to be input to the terminal block.

Settings of frequency priority parameter F200	Prior terminals	Description
0	VIA or II	If 0 is input to the VIB terminal, a command input to the VIA or II terminal is valid.
1	VIB	If 0 is input to the VIA and II terminals, a command input to the VIB terminal is valid.

Connecting and Calibrating Meters

Applicable parameters: FM terminal function selection *fmsl*, meter adjustment *Fm*

An analog meter can be connected to the FM terminal to act as a frequency meter or an output current meter.

How to connect a meter to measure frequency

Set the FMSL value to "0". It is set to "0" by default.

How to connect a meter to measure output current

Set the FMSL value to "1".

When measuring output current, use a meter whose full scale rating (1mA or 7.5V) is equivalent to 2.25 times the rated inverter current.

How to calibrate the frequency meter or ammeter

- 1) Start the drive. When an ammeter is to be adjusted, connect the motor. (See "OPERATIONS".)
- 2) Increase the frequency within the safe range.
- 3) Press the MON key to display AUI.
- 4) Press the UP key six times to display Fm.
- 5) Press the ENT key.
- 6) The operation frequency or current (%) is displayed on the display.
- 7) Adjust the reading of the analog meter to the displayed frequency or current with the UP or DOWN key.
- 8) After completing the adjustment, press the ENT key.
- 9) Press the MON key twice. The current frequency is displayed.
- 10) Stop the drive.

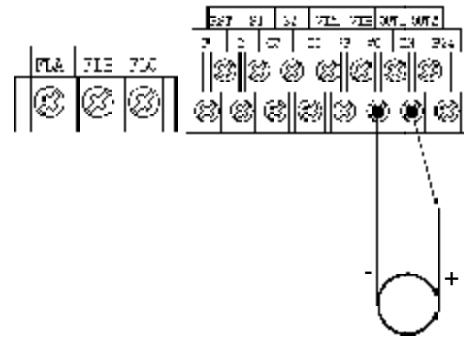
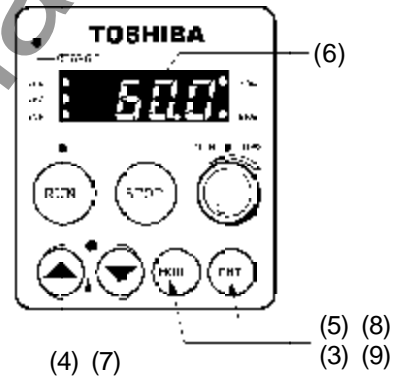

1 mA ammeter
of
7.5Vdc voltmeter

Resetting to Default Values

Applicable parameters: Standard setting mode selection tYP

All parameters can be reset to the default values when set to "3". If the 50 Hz or 60 Hz setting is selected, FH, UL, uL, F204, F213 are set for 50 Hz or 60 Hz and other parameters are set to the factory default values. The tYP parameter cannot be changed while running.

Settings	Set value
Not changed	0
Parameter setting for 50 Hz motor	1
Parameter setting for 60 Hz motor	2
Default setting (All parameters)	3
Clears the error log	4
Clears accumulative run time *	5
Initialize drive typeform **	6

* Accumulative time is cumulative run time for which the inverter output frequency is more than 0.0Hz and unit is 100 hours.

** tYP 6 is used to clear an EtYP error that may occur when the control PCB is installed in a different inverter unit and to reset the typeform to that of the new drive.

Notes:

- 1) When this parameter is selected, the previous set value is displayed at the left end and 0 is always displayed at the right end. The previous set value is 3 by default.
- 2) Parameters different from the default values can be checked using the user parameter group gr.U.

Setting The Motor Protection Characteristics

Applicable parameters: Selection of electric thermal protection characteristics OLn

The "thermal protection type" can be specified according to the motor type. Normally select 0 for the motor or 4 for a VF motor for the drive.

Notes:

- 1) The selection of electric thermal protection in the drive eliminates the need to use an external thermal relay for motor protection.
- 2) If the rated current is different from the rated motor current (continuous), set the ratio using parameter f600.



CAUTION

If a single drive is used to control several motors, install a separate thermal relay for each motor. Set the thermal function F600 to match the rated current of the motor. Failure to correctly set this value could result in motor overheating and a possible fire.

Setting The Extended Parameters

Applicable parameters: Extended parameters f---

The extended parameters are used to make the drive deliver its full performance. To use the extended parameters, call the parameter **f---** and press the ENT key. The extended parameter number is displayed. Once the number is displayed, the extended parameter can be set in the same way as the normal parameters. After setting the extended parameters, press the MON key.

Refer to pages 37 to 39 for lists of the extended parameters. For detail of the parameters and how to use them, contact your Toshiba distributor.

Searching For Parameters Different from Default Values

Applicable parameters: Automatic edit function Gr.U

The parameters which are different from the default values can be displayed. Call the parameter **Gr.U**, then press the ENT key. The names of the parameters which are different from the default values are displayed. If several parameters are different from the default values, they can be seen by pressing the UP or DOWN key. These parameters can be changed in the same way as the normal parameters. After completing the operation, press the MON key.

Parameter List

Basic Parameters (Group No. 00)

Display	Function	Adjustable range				Default value
aU1	Automatic acceleration and deceleration	0: No, 1: Yes				0
aU2	Automatic torque boost * * These parameters cannot be changed while running	0: No 1: Automatic torque boost 2: Sensorless vector control 3: Sensorless vector control with automatic tuning				0
aU3	Automatic environment setting *	0: No 1: Automatic 50 Hz motor 2: Automatic 60 Hz motor				0
cMOd	Command mode selection	0: Terminal block, 1: Panel				1
fMOd	Frequency setting mode selection	0: Terminal block, 1: Panel, 2: Built-in potentiometer				2
fMSl	FM terminal function selection	0: Frequency meter, 1: Output current meter				0
fM	Connected meter adjustment	Frequency or current displayed				-
typ	Standard setting mode selection *	0: No action, 1: 50 Hz standard 2: 60 Hz standard 3: Default setting 4: Clears error log 5: Clearing accumulated operation time 6: Initialize inverter typeform				3
fr	Forward/reverse selection (Panel)	0: Forward, 1: Reverse				0
acc	Acceleration time #1 (s)	0.1 ~ 3600				10.0
dec	Deceleration time #1 (s)	0.1 ~ 3600				10.0
fH	Max. frequency (Hz) *	30.0 ~ 320.0				80.0
UL	Upper limit frequency (Hz)	0.5 ~ FH				80.0
lL	Lower limit frequency (Hz)	0.0 ~ UL				0.0
ul	Base frequency (Hz)	25.0 ~ 320.0				60.0
pt	V/f pattern *	0: Constant V/f 1: Square reduction 2: Automatic torque boost 3: Sensorless vector control 4: Automatic energy saving				0
ub	Voltage boost (%)	0.0 ~ 30.0 Refer to Default Value table page 52				Table
OLM	Selection of electronic thermal protection characteristics	Setting	Type	Overload protection	Overload stall	0
		0	Standard motor	O	X	
		1		O	O	
		2		X	X	
		3		X	O	
		4	V/F motor	O	X	
		5		O	O	
		6		X	X	
7	X	O				
Sr1~ Sr7	Preset speed 1 to 7. (Hz)	LL ~ UL				0.0
F---	Extended parameters	---				
grU	Automatic edit function	Changed parameters displayed				

Parameter List (cont'd)

Extended Parameters (I/O Group No. 01)

Display	Function	Adjustable range	Default value
F1 00	Low speed signal output (Hz)	0.0 ~ FH	0.0
F1 01	Speed reach HI frequency (Hz)	0.0 ~ FH	0.0
F1 02	Acc/Dec complete detection bandwidth (Hz)	0.0 ~ FH	2.5
F1 03	ST signal selection	0: Standard, 1: Normally ON, 2: Linking with F/R	1
F1 04	RST signal selection	0: Standard, 1: Resetting if no signal is input to terminal	0
F1 10	Always active function selection	0 ~ 37 Refer to Input Terminal Selection table page 51.	0: No function provided
F1 11	Input terminal selection #1	0 ~ 37 Refer to Input Terminal Selection table page 51.	2 : F
F1 12	Input terminal selection #2	0 ~ 37 Refer to Input Terminal Selection table page 51.	3 : R
F1 13	Input terminal selection #3	0 ~ 37 Refer to Input Terminal Selection table page 51.	10 : RST
F1 14	Input terminal selection #4	0 ~ 37 Refer to Input Terminal Selection table page 51.	6 : S1
F1 15	Input terminal selection #5	0 ~ 37 Refer to Input Terminal Selection table page 51.	7 S2
F1 30	Output terminal selection #1	0 ~ 9 Refer to Output Terminal Selection table page 52.	4 : LOW
F1 31	Output terminal selection #2	0 ~ 9 Refer to Output Terminal Selection table page 52.	6 : RCH

Extended Parameters (Frequency Group No. 02)

Display	Function	Adjustable range	Default value
F200	Frequency priority selection	0 : VIA, 1 : VIB	0
F201	VIA reference point #1 (%)	0 ~ 100	0
F202	VIA point #1 frequency (Hz)	0.0 ~ 320.0	0.0
F203	VIA reference point #2 (%)	0 ~ 100	100
F204	VIA point #2 frequency (Hz)	0.0 ~ 320.0	80.0
F210	VIB reference point #1 (%)	0 ~ 100	0
F211	VIB point #1 frequency (Hz)	0.0 ~ 320.0	0.0
F212	VIB reference point #2 (%)	0 ~ 100	100
F213	VIB point #2 frequency (Hz)	0.0 ~ 320.0	80.0
F240	Start-up frequency (Hz)	0.5 ~ 10.0	0.5
F241	Run frequency (Hz)	0.0 ~ FH	0.0
F242	Run frequency hysteresis (Hz)	0.0 ~ FH	0.0
F250	DC injection starting frequency (Hz)	0.0 ~ FH	0.0
F251	DC injection current (%)	0 ~ 100	30
F252	DC injection time (s)	0.0 ~ 20.0	1.0
F260	Jog run frequency (Hz)	0.0 ~ 20.0	0.0
F261	Jog stop control	0: Ramp to stop 1: Coast to stop 2: DC	0
F270	Jump frequency #1 (Hz)	LL ~ UL	0.0
F271	Jump frequency band #1 (Hz)	0.0 ~ 30.0	0.0
F272	Jump frequency #2 (Hz)	LL ~ UL	0.0
F273	Jump frequency band #2 (Hz)	0.0 ~ 30.0	0.0
F274	Jump frequency #3 (Hz)	LL ~ UL	0.0
F275	Jump frequency band #3 (Hz)	0.0 ~ 30.0	0.0
F280	Preset speed 1 to 15 (Hz)	LL ~ UL	0.0
-F284			

Parameter List (cont'd)

Extended Parameters (Operating Mode Group No. 03)

Display	Function	Adjustable range	Default value
F300	PWM carrier frequency (kHz)	2.2 ~ 12.0	12.0
F301	Auto-restart	0: No, 1: Instantaneous power failure, 2: ST, 3: Instantaneous power failure + ST	0
F302	Regeneration power ride-through control	0: No, 1: Yes	0
F303	Retry selection (Number of times)	0 ~ 10	0
F304	Regenerative braking selection	0: No, 1: Yes	0
F305	Overvoltage stall protection	0: Enabled, 1: Disabled	0
F306	Output voltage adjustment (%)	0 ~ 120	100
F307	Line voltage compensation (cannot be changed while running)	0: No, 1: Yes	0
F308	Braking resistor overload detection time constant	1 ~ 255	39
F360	PI control	0: No, 1: Yes	0
F362	Proportional gain	0.01 ~ 100.0	0.30
F363	Integral gain	0.01 ~ 100.0	0.20

Extended Parameters (Torque Group No. 04)

Display	Function	Adjustable range	Default value
F400	Automatic tuning (cannot be changed while running)	0: Use factory setting, 1: Use F401 ~ F404, 2: Automatic Tuning	0
F401	Slip frequency gain	0 ~ 255 Refer to Default Value table page 52.	Table
F402	Motor constant 1	0 ~ 255 Refer to Default Value table page 52.	Table
F403	Motor constant 2	0 ~ 255 Refer to Default Value table page 52.	Table
F404	Motor constant 3	0 ~ 255 Refer to Default Value table page 52.	Table
F405	Load inertia	0: Small, 1: Medium, 2: Large, 3: Very large	0

Extended Parameters (Acceleration & deceleration time Group No. 05)

Display	Function	Adjustable range	Default value
F500	Acceleration time #2 (s)	0.1 ~ 3600	10.0
F501	Deceleration time #2 (s)	0.1 ~ 3600	10.0
F502	Acceleration & deceleration pattern #1	0: Linear	0
F503	Acceleration & deceleration pattern #2	1: S shape pattern 1 2: S shape pattern 2	0
F504	Acceleration & deceleration patterns # & #2 selection	0: Acceleration & deceleration pattern 1 1: Acceleration & deceleration pattern 2	0
F505	Acceleration/deceleration patterns #1/#2 switching frequency (Hz)		0.0

Parameter List (cont'd)

Extended Parameters (Protection Group No. 06)

Display	Function	Adjustable range	Default value
F600	Motor overload protection level (%)	10 ~ 100	100
F601	Stall protection level (%)	10 ~ 199, 200 (OFF)	150
F602	Fault trip saving	0: No, 1: Yes	0
F603	Emergency stop selection	0: Coast to stop 1: Stopping after deceleration 2: Stopping by emergency DC braking	0
F604	Emergency DC inject time (s)	0.0 ~ 20.0	10
F605	Open phase detection parameter	0: Not activated 1: Activated (first running only at start up after power on) 2: Activated (running only at start up)	0

Extended Parameters (Panel Group No. 07)

Display	Function	Adjustable range	Default value
F700	Parameter setting disable selection	0: Enable (except FMod and CMod in running) 1: Disable 2: Enable	0
F701	Unit selection	0: Not changed 1: Change % into A, V 2: F702 enable 3: Convert % into A, V, F702 enable	0
F702	Frequency units multiplication factor	0.01 ~ 200.0	1.00

Extended Parameters (Communication Group No. 08)

Display	Function	Adjustable range	Default value
F800	Communication speed	0: 1200bps 1: 2400bps 2: 4800bps 3: 9600bps	3
F801	Parity	0: NONE 1: EVEN 2: ODD	1
F802	Inverter number	0 ~ 63	0
F803	Communication error trip time (s)	0 (OFF), 1 ~ 100	0

Operations



CAUTION Review all operating precautions on page 11 before operating this drive.

Operation with Built-in Potentiometer and RUN and STOP Keys

- 1) Connect the cables to the motor and power source.
- 2) Turn the built-in potentiometer fully counterclockwise.
- 3) Turn on the power.
- 4) 00 is displayed on the display unit.
- 5) Press the RUN key.
- 6) Turn the built-in potentiometer clockwise gradually.
- 7) The RUN lamp goes on. The motor starts and its rotation speed increases gradually.
- 8) The operation frequency is displayed on the display unit.
- 9) To stop the motor, press the STOP key.
- 10) The motor speed decreases according to the deceleration pattern.
- 11) The RUN lamp goes out.



Operations (cont'd)

Operation with Built-in Potentiometer and External Start Signal

- 1) Connect the cables to the motor and power source. (See "CONNECTING OF THE MAIN CIRCUITS.")
- 2) Connect a start/stop switch between the control terminal F and CC (for forward rotation) or between R and CC (for reverse rotation). (See "CONNECTING THE CONTROL WIRES.")

- 3) Turn the built-in potentiometer fully counterclockwise.
- 4) Turn on the power.
- 5) Set the parameters C008 to 0 and F008 to 2. (See "Setting the Starting and Stopping Methods" and "Setting the Frequency Command Method".)



- 6) 0.0 is displayed on the display unit.
- 7) Turn on the forward or reverse switch.

- 8) Turn the built-in potentiometer clockwise gradually.
- 9) The RUN lamp goes on. The motor starts and its rotation speed increases gradually.

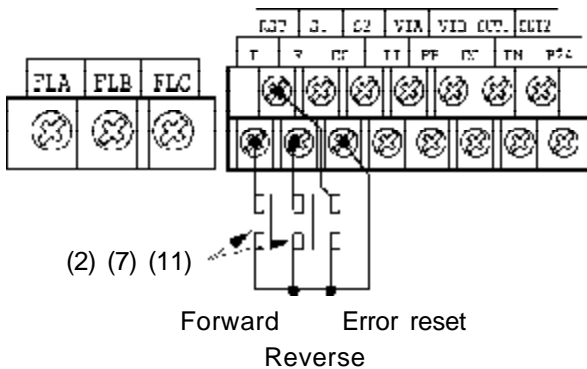

- 10) The operation frequency is displayed on the display unit.
- 11) To stop operation, turn off the forward or reverse switch.
- 12) The motor speed decreases according to the deceleration pattern.
- 13) The RUN lamp goes out.

Operations (cont'd)

Setting the Frequency using External (0 - 10 V Voltage/4 - 20 mA Current) Signal and Operating using an External Start Signal

- 1) Connect the cables to the motor and power source.
- 2) Connect a start/stop switch between the control terminal F and CC (for forward rotation) or between R and CC (for reverse rotation).

External voltage command:

Set the command voltage to 0 V. Apply the command voltage between the control terminal VIA and CC (on the 0 V side).

External current command:

Set the command current to 4 mA. Apply the command current between the control terminal II and CC (on the 0 V side). (See "CONNECTION OF CONTROL SIGNALS.")

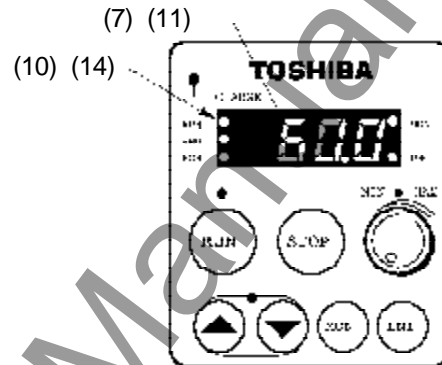

- 3) Turn on the power.
- 4) Set the parameter CM08 to "0". (See "Setting the Starting and Stopping Methods.")
- 5) Set the parameter FM08 to "0". (See "Setting the Frequency Instruction Method.")

- 6) If the external current command (4 to 20 mA) is used, set the parameter F20I to "20".

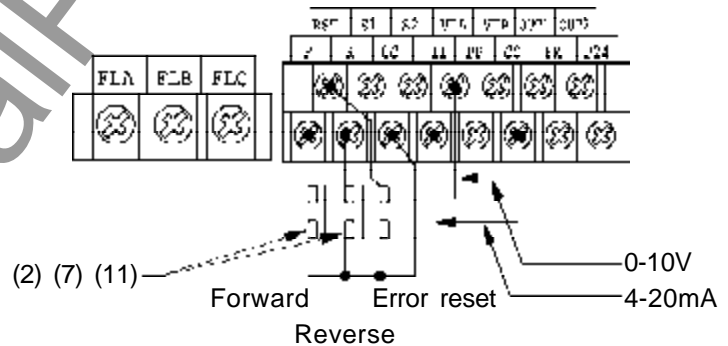

- 7) "00" is displayed on the display unit.
- 8) Turn on the forward or reverse switch.
- 9) Increase the voltage or current command gradually.
- 10) The RUN lamp goes on. The motor starts and its speed increases gradually.
- 11) The operation frequency is displayed on the display unit.
- 12) To stop operation, turn off the forward or reverse switch.
- 13) The motor speed decreases according to the deceleration pattern.
- 14) The RUN lamp goes out.

Operations (cont'd)

Setting the Frequency using Two External (0 - 10 V Voltage/4 - 20 mA Current) Signal and Operating using an External Start Signal

- 1) Connect the cables to the motor and power source.
- 2) Connect a start/stop switch between the control terminal F and CC (for forward rotation) or between R and CC (for reverse rotation).
- 3) Apply two frequency commands to VIA (voltage command) and VIB (voltage command) or VIB (voltage command) and II (current command).
 External voltage command: Set the command voltage to 0 V.
 Apply the command voltage between the control terminal VIA and CC (on the 0 V side).

 External current command: Set the command current to 4 mA.
 Apply the command current between the control terminal II and CC (on the 0 V side).
 (See "CONNECTING THE CONTROL SIGNAL.")

- 4) Turn on the power.
- 5) Set the parameter CM08 to "0".
(See "Setting the Starting and Stopping Methods.")
- 6) Set the parameter FM08 to "0".
(See "Setting the Frequency Command Method.")
- 7) Specify, using the parameter F200, whether to give priority to VIB and VIA or II. (See "Setting the Frequency Command Method.")
- 8) If the external current command (4 to 20 mA) is used, set the parameter F201 to "20".
- 9) "0.0" is displayed on the display unit.
- 10) Turn on the forward or reverse switch.
- 11) Increase the voltage current command gradually.
- 12) The specified frequency command is used, when it is not "0". When it is "0", another frequency command is used.
- 13) The RUN lamp goes on. The motor starts and its revolution speed increases gradually.
- 14) The operation frequency is displayed on the display unit.
- 15) To stop operation, turn off the forward or reverse switch.
- 16) The motor revolution speed decreases according to the deceleration pattern.
- 17) The RUN lamp goes out.

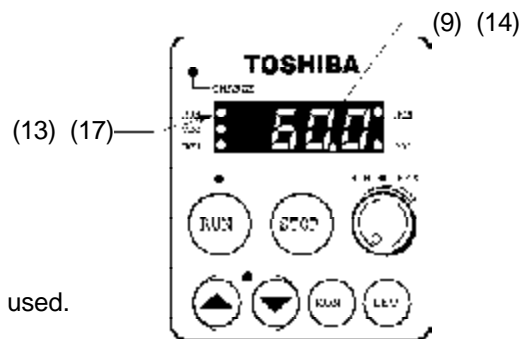
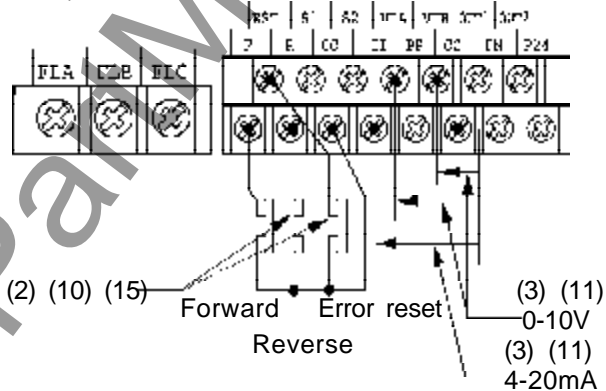

Operations (cont'd)

Selecting a Preset Speed Frequencies, and Operating using an External Start Signal

- 1) Connect the wires to the motor and power source.
(See "CONNECTING OF THE MAIN CIRCUITS.")
- 2) Connect a start/stop switch between the control terminal F and CC (for forward rotation) or between R and CC (for reverse rotation).
(See "CONNECTING OF THE CONTROL SIGNALS.")
- 3) Connect a frequency selector switch between the control terminals S1 and S2 and CC.
- 4) Turn on the power.
- 5) Set the desired frequency using the parameter 5r1. 5r2. 5r3.
- 6) The frequency alternates when the switches connected to S1 and S2 is turned on (closed) and turned off (opened). Select the desired frequency.
- 7) If both S1 and S2 are turned off, the frequency set with the parameter Fm0d is selected.
(Built-in potentiometer by default)
Set this frequency to 0. (When the built-in potentiometer is used for control, turn it fully counterclockwise.)
- 8) "00" is displayed on the display unit.
- 9) Turn on the forward or reverse switch.
- 10) If both S1 and S2 are off and the command is set to 0, increase the command level.
- 11) The RUN lamp goes on. The motor starts and its rotation speed increases gradually.
- 12) The operation frequency is displayed on the display unit.
- 13) To stop operation, turn off the forward or reverse switch.
- 14) The motor speed decreases according to the deceleration pattern.
- 15) The RUN lamp goes out.

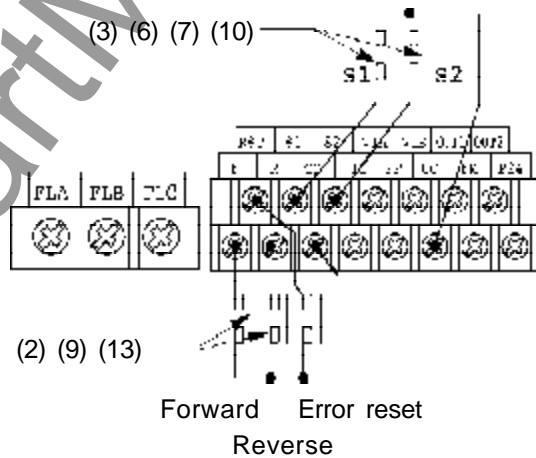
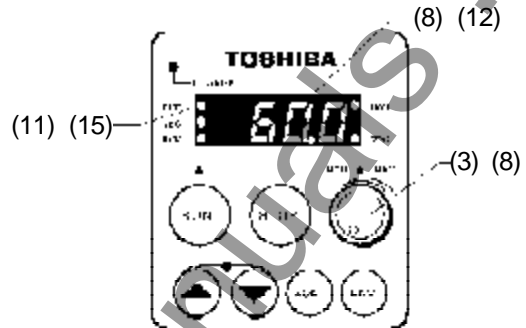

Preset speed selection chart				
S1	OFF	S2	OFF	
S1	ON	S2	OFF	Sr1
S1	OFF	S2	ON	Sr2
S1	ON	S2	ON	Sr3

Notes:

- 1) A maximum of fifteen internal speed set values are available by changing the functions of the control terminals.

Monitoring Operating Conditions

The conditions of the drive during operation or in case of a trip can be checked as shown below.

- 1) Keep the MON key depressed until the MON lamp goes on.
- 2) The first monitor item "Rotational Direction **Fr -**" is displayed on the display unit.
- 3) Select a desired monitor item with the UP or DOWN key.
- 4) After completing the monitoring, press the MON key.
- 5) The operating frequency is displayed on the display unit.

Example of Displaying the drive condition

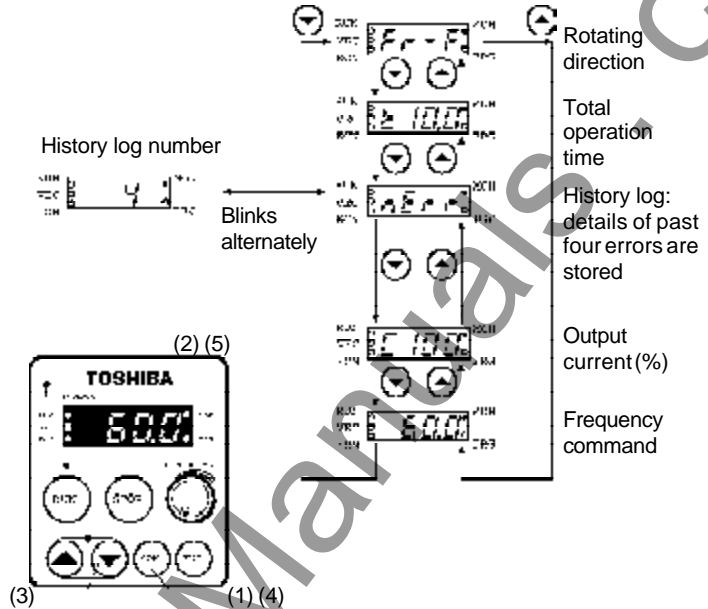

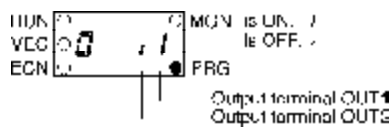
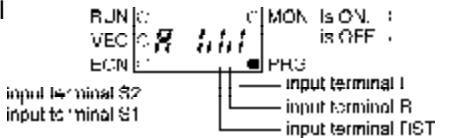
Monitor items	Display	Descriptions
Rotating direction	Fr -	Forward rotation: Fr-F, reverse rotation: Fr-r
Cumulative run time	t _	Cumulative run time for which the drive output frequency is more than 0.0 Hz (i.e., operating condition) (0.01 corresponds to one hour.)
Past trip #4	4 ↔	Cause of the fourth previous fault counted from the latest fault. Cause and sequence 4 are displayed alternately.
Past trip #3	3 ↔	Cause of the third previous fault counted from the latest fault. Cause and sequence 3 are displayed alternately.
Past trip #2	2 ↔	Cause of the second previous fault counted from the latest fault. Cause and sequence 2 are displayed alternately.
Past trip #1	1 ↔	Cause of the latest fault. Cause and 1 are displayed alternately.
Memory version	uE _	Version of the internal memory
CPU version	u _	Version of the internal microprocessor
Output terminal status monitor	0 _	ON/OFF condition of the control output signals 
Input terminal status monitor	A _	ON/OFF condition of the control input signals 
Output voltage monitor	P _	Output voltage of the inverter (%)
Input voltage monitor	Y _	Input voltage of the inverter (%)
Load current monitor	C _	Ratio of the output current to the rated inverter current (%)
Operation frequency command value	- - -	Operation frequency command (Hz)

Protective Functions (Trips Information)

Trips and Countermeasures

Display	Description	Countermeasures
OC1	Overcurrent during acceleration	1) Increase the acceleration time (acc) 2) Increase or decrease the torque boost level (vb)
OC2	Overcurrent during deceleration	1) Increase the deceleration time (dEC).
OC3	Overcurrent during constant-speed run	1) Reduce the variance of the load conditions.
OCA	Phase short circuit	1) The main circuit is abnormal. Ask your agent to repair the inverter.
OCL	Load-end short circuit (output terminal check) trip during start-up	1) The insulation of the main output circuit or motor is abnormal. 2) Check the wiring and insulation. 3) If 1 and 2 are normal, the elements of the main circuit may be defective. Ask your agent to repair the inverter.
OP1	Overvoltage during acceleration	1) Check the power voltage. 2) Check if the power is turned on and off frequently. 3) Check whether or not excessive current flows instantaneously through a load.
OP2	Overvoltage during deceleration	1) Increase the deceleration time (dEC).
OP3	Overvoltage	1) Check the power voltage. 2) Check if the power is turned on and off frequently. 3) Check whether or not excessive current flows instantaneously through a load.
mOFF	Undervoltage	1) The input voltage is too low. 2) Check the power supply condition and input wiring.
OL 1	Drive overload trip	1) The load is excessive. Reduce it.
OL 2	Motor overload trip	2) The V/f characteristics or torque boost level are not proper. Check whether or not a 50 Hz rated motor runs on the 60 Hz base frequency. Increase or decrease the torque boost level. 3) Increase the drive rating.
OLr	Braking resistor overload trip	1) Increase the deceleration time (dEC).
OH	Overheat trip	1) Check whether or not the ambient temperature is too high. If the ambient temperature is too high, remove the seal from the top cover.
E	Emergency stop	1) Operation stops on the panel during automatic or remote operation.
E0FF	Checking emergency stop acceptance display	1) Operation stops on the panel during automatic or remote operation. Stop operation in an emergency by pressing the STOP key twice. To cancel an emergency stop, press any other key.
EEPI	EEPROM fault	1) Turn off the power, then turn it on again. 2) If the EEPROM does not recover from the error, ask your agent to repair the drive.

Protective Functions (Trips Information)

Trips and Countermeasures

Display	Description	Countermeasures
Etn	Automatic tuning error	1) Check the Torque up parameters.
EPH0	Output phase loss	1) Output phase loss occur.
Err.1	Frequency setting signal error	1) The point 1 and point 2 frequency setting signals parameter are too close to each other. Reset these signals so that points 1 and 2 are apart from each other.
Err.2	RAM fault	1) Ask your agent to repair the drive.
EFF.3	ROM fault	1) Ask your agent to repair the drive.
EFF.4	CPU fault	1) Ask your agent to repair the drive.
EFF.5	Communication interruption error	1) Check the communication device, wiring, etc.
etyp	Inverter typeform error	1) If the PCB is replaced, set standard setting mode selection (EYP) to 6 in order to clear the error.
C	Stall prevention alarm	1) Increase the acceleration time (ACC). 2) Increase or decrease the torque boost level.
P	Overvoltage alarm	1) Increase the deceleration time (dEC).
L	Overload alarm	1) The load is excessive. Reduce it. 2) Increase the drive rating.
HI LO	Set value alarm (Error message and data are displayed twice each alternately.)	1) An incorrect set value is found when reading or writing data. Check the set values, then reset the incorrect value.

Resetting Errors When Trip is Activated



CAUTION

Eliminate the cause of the error before resetting or drive damage can result. If a protective function is activated due to overload or heat, wait for five minutes or more to reset the error.

To reset the protective function, do any of the following:

- 1) Turn on and off the error reset control input signal.
- 2) Press the STOP key twice while the protective function is displayed.
- 3) Turn off the power.

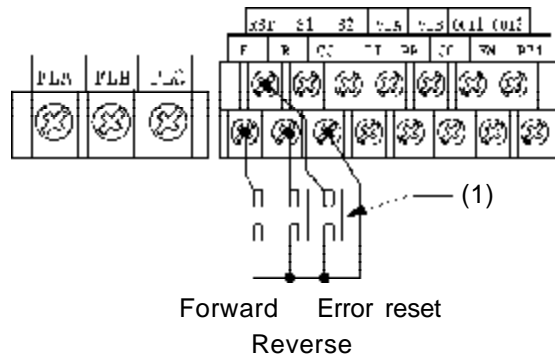

Dimensions for VFS5-5020UPH through VFS5-5040UPH

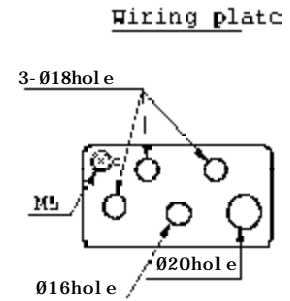
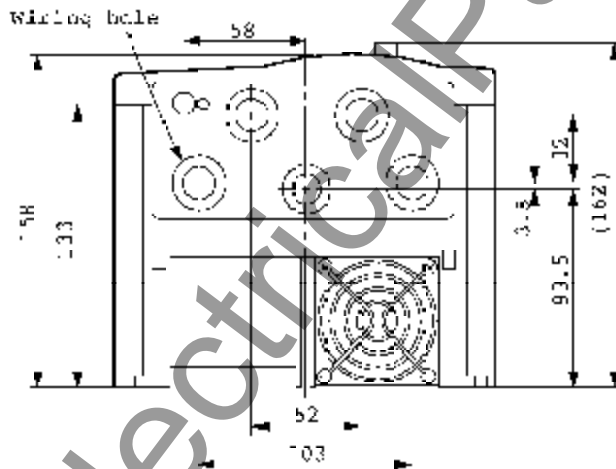
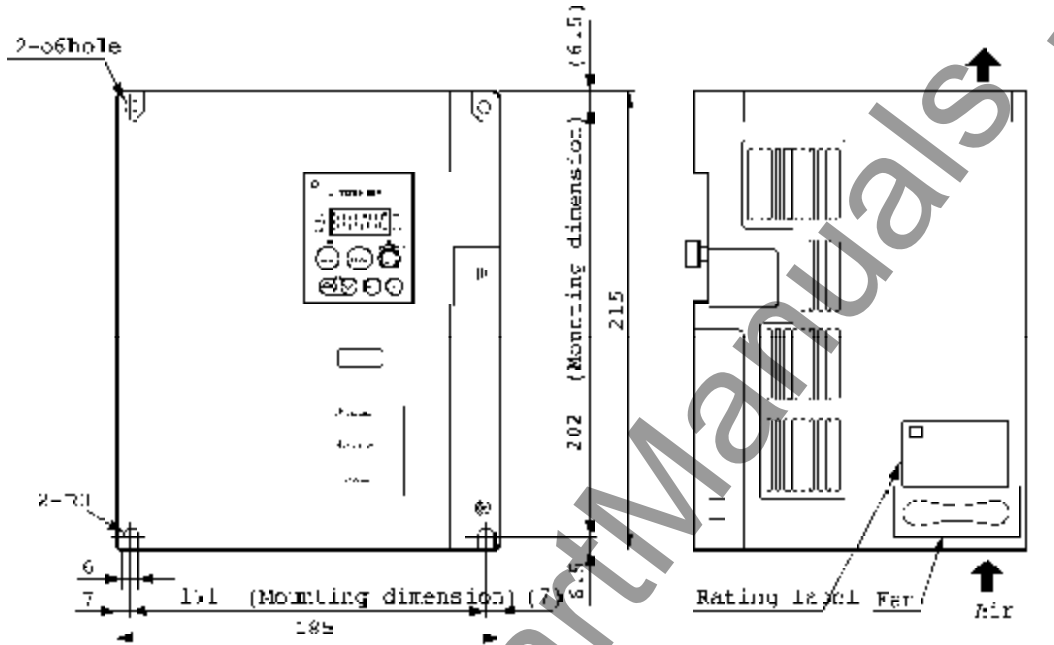

Unit: mm

Type	Approx. weight
VFS5-5020UPH	3.5 kg
VFS5-5030UPH	3.5 kg
VFS5-5040UPH	3.5 kg

Dimensions for VFS5-5060UPH through VFS5-5120UPH

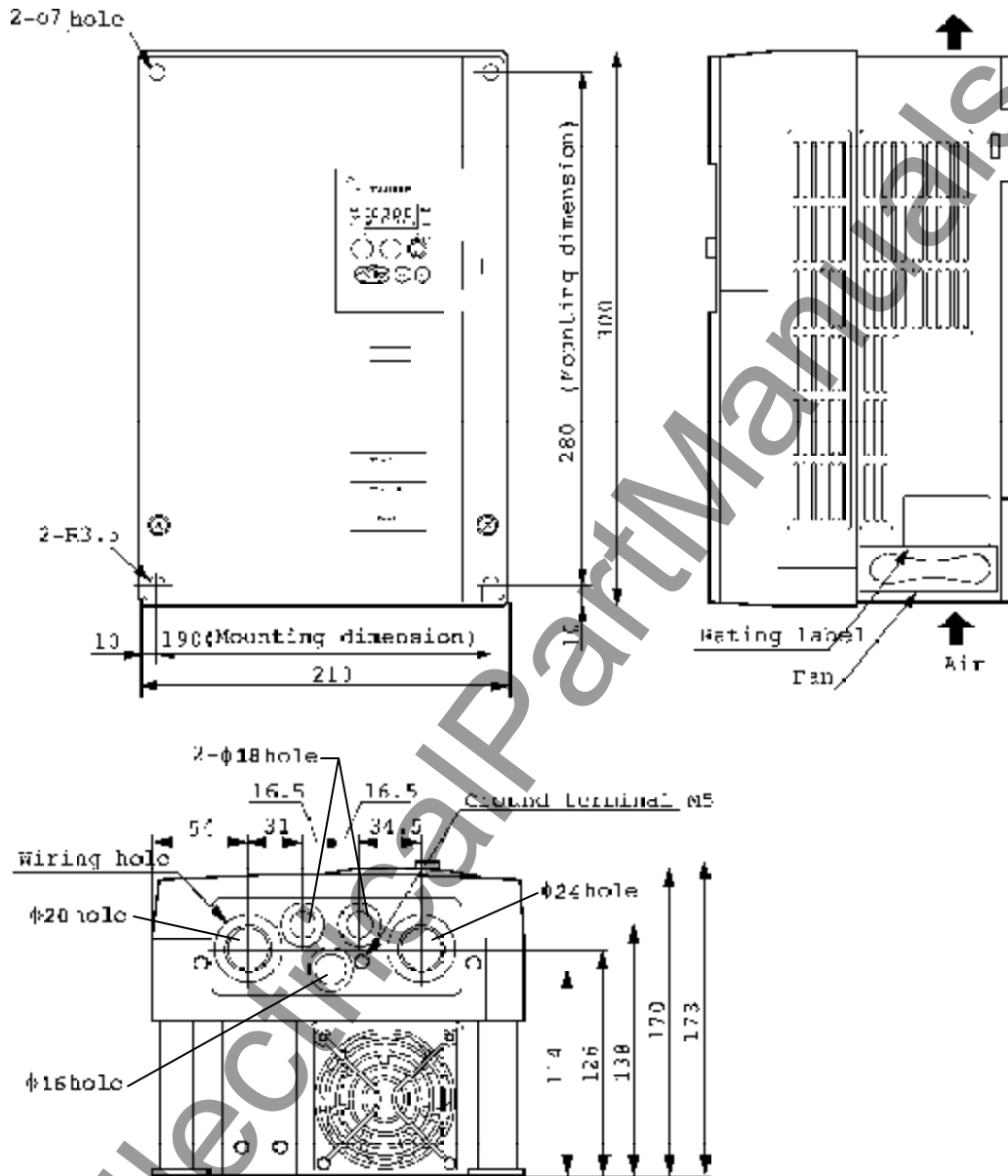

Unit: mm

Type	Approx. weight
VFS5-5060UPH	7.0 kg
VFS5-5120UPH	7.0 kg

Dimensions for VFS5-5160UPH through VFS5-5270UPH

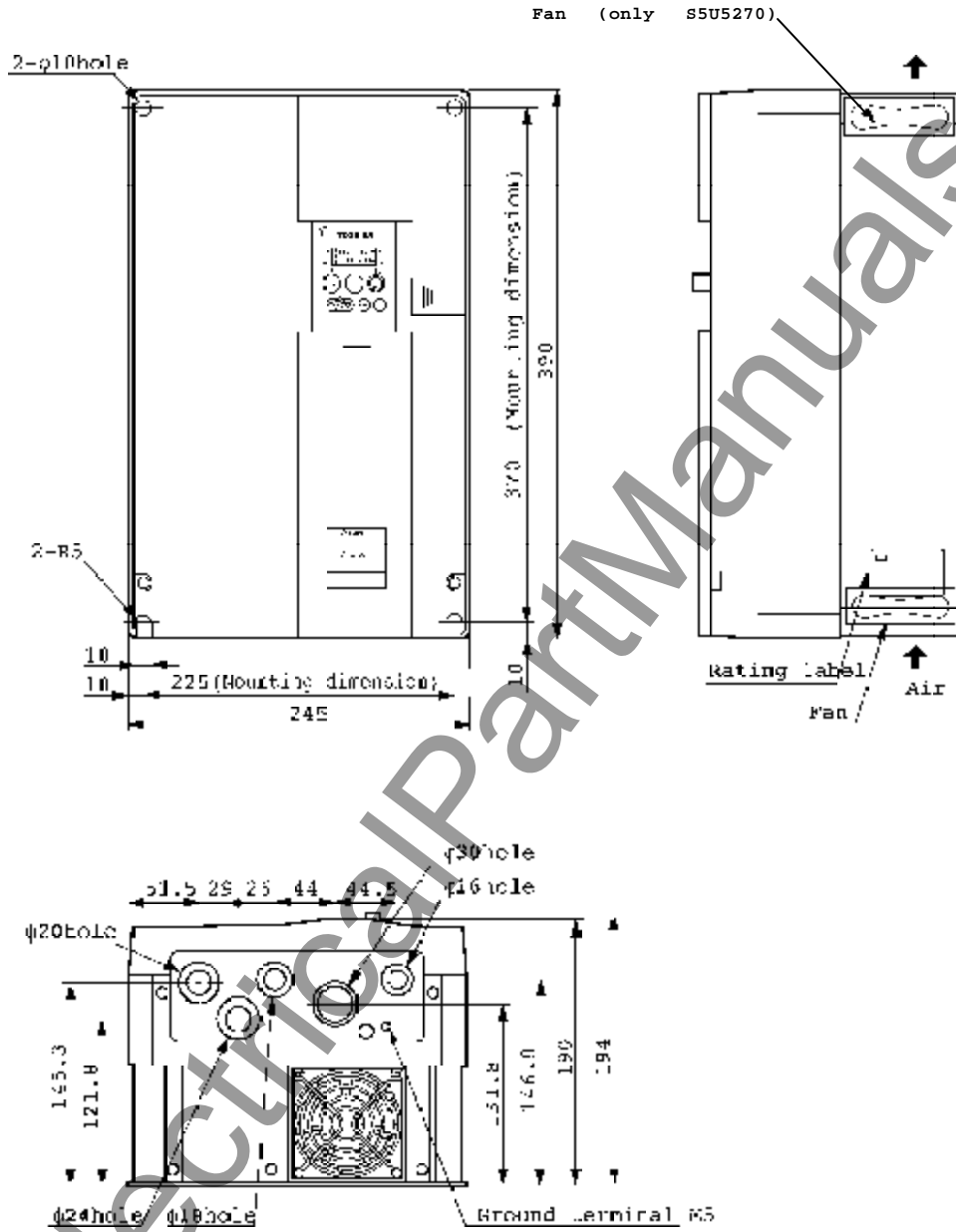

Unit: mm

Type	Approx. weight
VFS5-5160UPH	11.0 kg
VFS5-5220UPH	11.0 kg
VFS5-5270UPH	11.0 kg

Input Terminal Selection Table

Setting	Function	
0	Off	(No effect)
1	ST	(Gate ON/OFF)
2	F	(Forward run)
3	R	(Reverse run)
4	JOG	(JOG selection)
5	AD2	(AD2 selection)
6	SS1	(15 Pre-set speed selection)
7	SS2	(15 Pre-set speed selection)
8	SS3	(15 Pre-set speed selection)
9	SS4	(15 Pre-set speed selection)
10	RST	(Fault reset)
11	EMG	(Emergency stop)
12	PNL/TB	(Panel/Terminal mode selection)
13	DB	(DC injection braking ON/OFF)
14	PI	(PI control disable)
15	PWREN	(Parameter changing selection)
16	ST+RST	(ST-RST combination)
17	ST+PNL/TB	(ST-PNL/TB combination)
18	F+JOG	(F-JOG combination)
19	R+JOG	(R-JOG combination)
20	F+AD2	(F-AD2 combination)
21	R+AD2	(R-AD2 combination)
22	F+SS1	(F-SS1 combination)
23	R+SS1	(R-SS1 combination)
24	F+SS2	(F-SS2 combination)
25	R+SS2	(R-SS2 combination)
26	F+SS3	(F-SS3 combination)
27	R+SS3	(R-SS3 combination)
28	F+SS4	(F-SS4 combination)
29	R+SS4	(R-SS4 combination)
30	F+AD2+SS1	(F-AD2-SS1 combination)
31	R+AD2+SS1	(R-AD2-SS1 combination)
32	F+AD2+SS2	(F-AD2-SS2 combination)
33	R+AD2+SS2	(R-AD2-SS2 combination)
34	F+AD2+SS3	(F-AD2-SS3 combination)
35	R+AD2+SS3	(R-AD2-SS3 combination)
36	F+AD2+SS4	(F-AD2-SS4 combination)
37	R+AD2+SS4	(R-AD2-SS4 combination)

Output Terminal Selection Table

Setting	Function	
0	LL	(Frequency lower limit)
1	LLN	(Opposite of LL)
2	UL	(Frequency upper limit)
3	ULN	(Opposite of UL)
4	LOW	(LOW speed signal)
5	LOWN	(Opposite of LOW)
6	RCH	(Acc/Dec complete)
7	RCHN	(Opposite of RCH)
8	RCHF	(Selected speed reach signal)
9	RCHFN	(Opposite of RCHF)

Default Value Table

Type Form	Voltage Boost	Slip frequency gain	Motor constant 1	Motor constant 1	Motor constant 1
	ub (%)	F401	F402	F403	F404
VFS5-5020UPH	3.0	87	27	149	29
VFS5-5030UPH	3.0	109	27	101	31
VFS5-5040UPH	3.0	60	23	51	38
VFS5-5060UPH	3.0	65	25	44	51
VFS5-5120UPH	2.0	61	22	20	56
VFS5-5160UPH	2.0	31	20	6	42
VFS5-5220UPH	1.0	35	17	5	44
VFS5-5270UPH	1.0	35	17	4	44

TOSHIBA

TOSHIBA INTERNATIONAL CORPORATION

INDUSTRIAL DIVISION

13131 West Little York Rd., Houston Texas 77041

Tel: [800] 231-1412 Fax: [713] 466-8773 Telex: 762078

World Wide Web <http://www.tic.toshiba.com>

Printed in U.S.A.