

**SIEMENS**

# Series 81000™

**5KV Medium Voltage Control  
OEM Kit**

**Instructions  
Installation  
Operation**

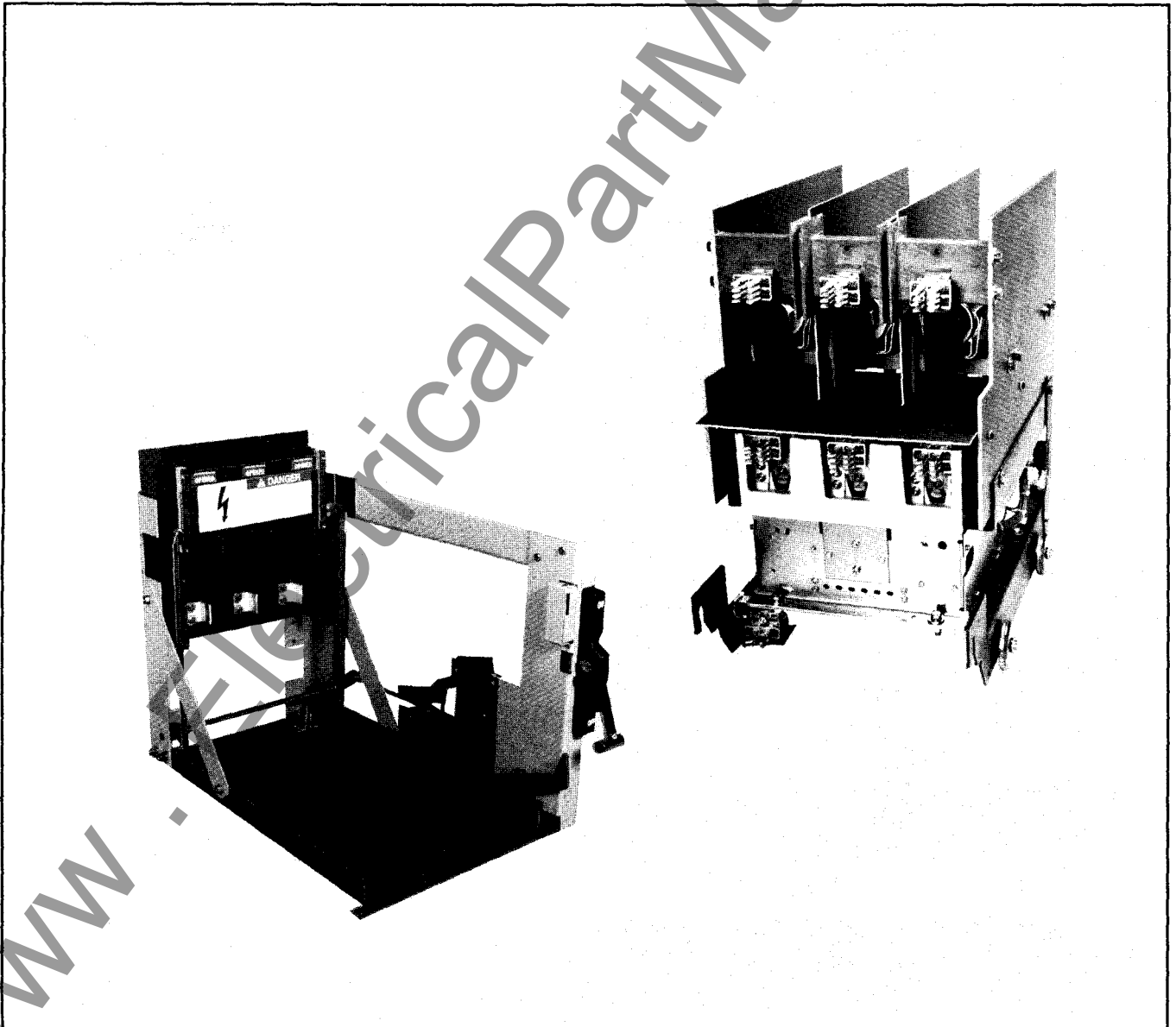

# General Information

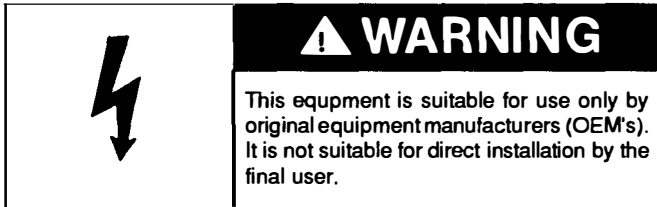

The Series 81000 OEM kit can be used as the basic building block to construct medium voltage starters for application to squirrel cage, synchronous and wound rotor motors. For control of Brush Type synchronous motors, the Series 85000 solid state control and protection module OEM kit is available.

Controller kits using both air-break and vacuum contactors are available. To accommodate the various contactors, three types of cell modules are offered:

## Description

The Series 81000™ medium voltage controller OEM kit consists of the following components:

1. Cell module assembly with pre-aligned 5KV line and load stabs, control power take-off stab, pre-adjusted racking mechanism with integrally mounted operating handle, plus all necessary racking and door interlocks.
2. Medium voltage drawout contactor.
3. Pre-fabricated wire harness with plug for connecting low voltage control power to contactor.

- 'Short' cell which accepts air-break contactors with single barrel power fuses
- 'Long' cell which accepts air-break contactors with double barrel power fuses
- 'Long' and 'Short' vacuum cell which accepts vacuum contactors with single or double barrel power fuses

Each cell module comes completely aligned and adjusted from the factory so it can be installed in the original equipment manufacturer's sheet metal enclosure without further adjustment. The contactor racking handle is an integral part of the cell module, therefore, no additional steps are required to mount it to the enclosure, connect linkages, etc.

Figure 1 identifies the major components of the cell module.

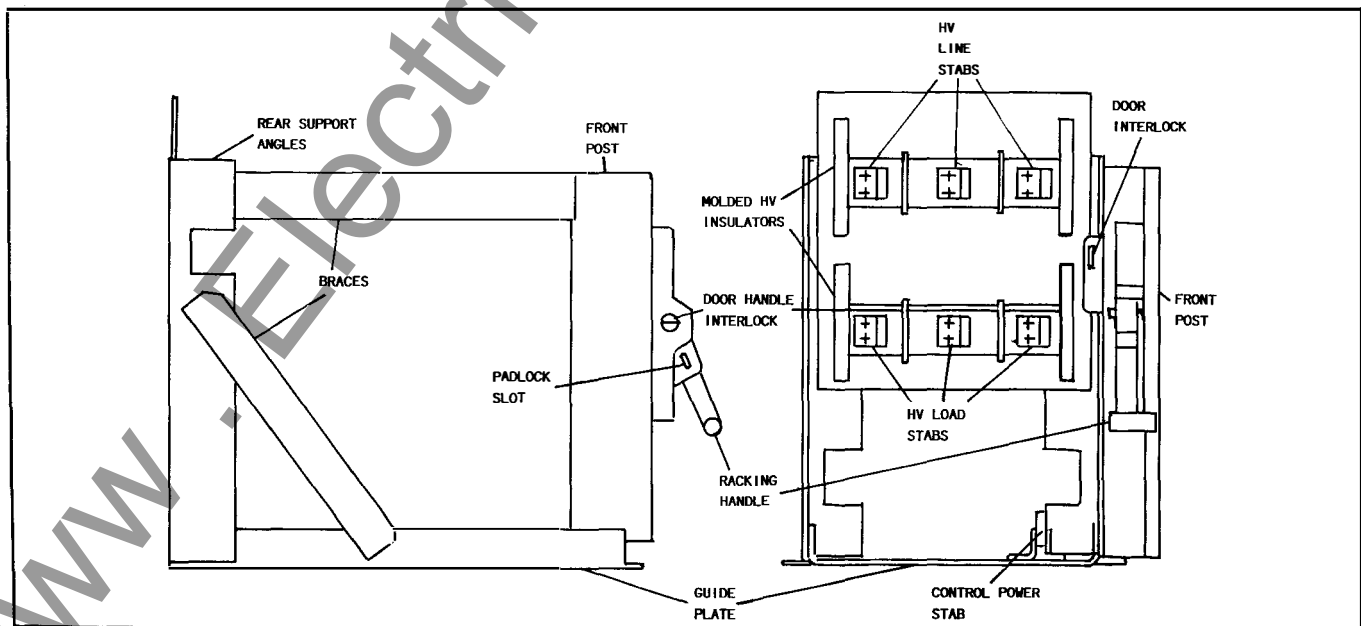

Figure 1. Cell Module Components

High voltage line and load connections are made to the upper and lower stations, respectively. A control wiring harness is provided for making control connections to the drawout contactor.

A control power transformer having up to 3.25 KVA maximum capacity can be provided mounted on the drawout contactor. One side of the secondary winding of this transformer is wired to ground and the other side is fed out through a stab assembly on the bottom of the contactor to a fixed terminal on the cell module. This arrangement ensures that control power is always safely disconnected when the contactor is withdrawn.

For instructions on operation and maintenance on Vacuum contactors see Bulletin CC3858.

For instructions on operation and maintenance on Air contactors see Bulletin CC3818.

### Drawout Contactors

Drawout contactors using either air-break or vacuum interrupters are available. Features which are common to both types of contactors are:

- Power fuses are mounted on contactor, supplied in ratings 2R through 24R for motor starting or 25E through 450E for transformer loads.
- Control power transformer and primary fuses are mounted on contactor, rated 0.75KVA through 3.25KVA, with 115V or 230V secondary.
- Drawout mechanism disconnects both line and load HV stabs, plus secondary of CPT
- Magnet coil is DC operated from rectified source, with economizing circuit.
- Mechanically latched contactors are available, with mechanical, electrical or capacitor (stored energy) trip
- Control connections are made through a wiring harness available with the OEM kit which plugs into the left side of the contactor
- 5KV insulation class
- 60KV BIL rating
- Auxiliary contacts-NEMA A600

Air-break contactors are available in 180 and 360 amp continuous ratings. Vacuum contactors are available in a 360 amp rating. Maximum ratings of contactors are given in Table 1.

# Installation

Horsepower, Current, Interruption and Voltage Maximum Ratings

Enclosed Continuous Ampere Rating	Interruption Capacity		Horsepower Rating at Utilization Voltage						KV Impulse Level (BIL)
	Unfused for Class E1 Controllers	Fused for Class E2 Controllers (MVA)	2300V, 3-Phase			4300-4600V, 3-Phase			
			Synchronous Motors		Induction Motors	Synchronous Motors		Induction Motors	
			0.8PF	1.0PF		0.8PF	1.0PF		
360 (vacuum)	5 KA@ 2300-4600V	200@2300V 350@4000V 400@4600V	1500	1750	1500	2500	3000	2500	60
360 (air)	50MVA@ 2300-4600V	200@2300V 350@4000V 400@4600V	1500	1750	1500	2500	3000	2500	60
180 (air)	25MVA@ 2300-4600V	200@2300V 350@4000V 400@4600V	700	900	700	1250	1500	1250	60

Table 1. Contactor Ratings

## Guidelines for Enclosure Design

Provide four (4) 3/8" diameter bolts or studs to line up with the .625 dia. holes at the locations shown in Figure 2 for attaching the bottom of the cell module to the supporting structure of the enclosure.

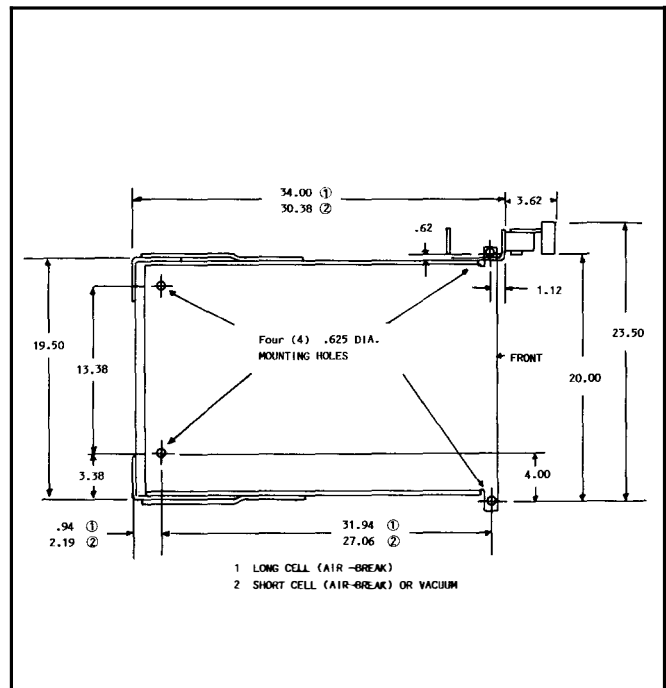

Figure 2. Cell Module Dimensions - Top View

# Installation

Each starter compartment must be at least 36 inches wide by 30 inches high. The minimum depth for the short cell module is 32 inches and for the long cell is 36 inches. The cell module should be positioned as far as possible to the right of the enclosure to allow space on the left for mounting current transformers and termination of outgoing load cables.

Incoming power via cable or bus bar should be con-

nected to the line (upper) stabs at the locations shown in Figure 3 using the 3/8" diameter bolts which attach the stabs to the insulator molding. The load (lower) stabs should be connected using cable to current transformers which are in turn connected to outgoing motor cables. Cables connected to lower stabs must be routed upward and then to the left through the notched left upright cell support angle. Cable routing must be as shown to prevent possible interference with the drawout contactor.

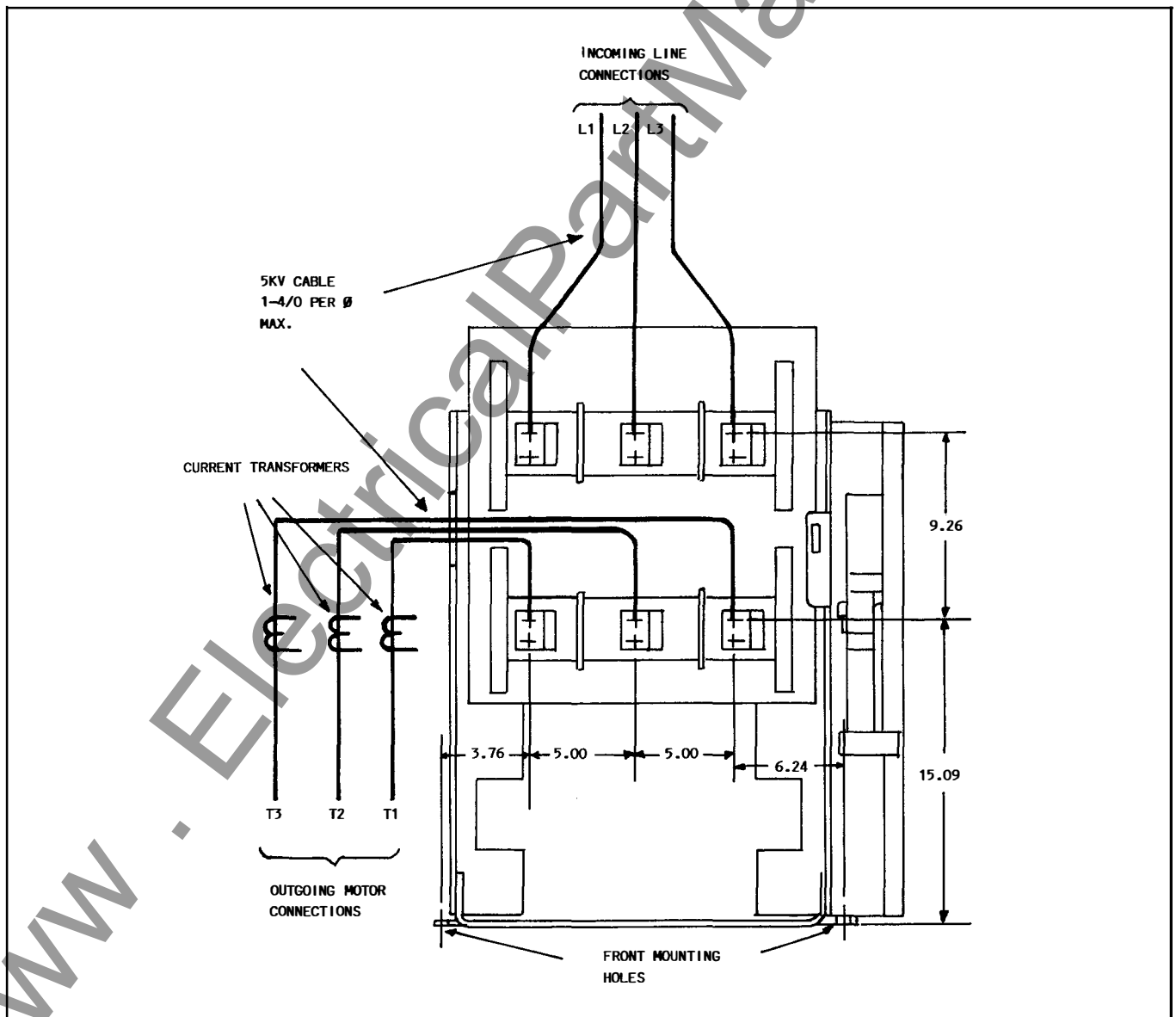

Figure 3. HV Line and Load Connections to Cell Module - Front View

# Installation

The cell module should be located so that the right front post which supports the racking handle housing is flush against the inside of the right stationary part of the enclosure. To accomplish this, the dimension from the inside of the enclosure to the front cell attachment bolts should be 1.12 inches. A suitably sized cutout is required in the enclosure (minimum 2.25 by 12.25 inches) to allow the racking handle and housing to protrude through the enclosure. If dusttight requirements exist, gasket around the edges of the cutout.

The enclosure door must be interlocked with the racking handle. To accomplish this, two parts (furnished with the OEM kit), called the door interlock and the door-handle interlock, must be attached to the door. These parts and their relationship with the racking handle are shown in Figure 4. The door interlock prevents moving the racking handle to the ON position unless the door is closed. The door-handle interlock prevents closing or opening the door except when the racking handle is in the OFF position. The flat profile on the end of the racking handle shaft will not allow the doorhandle interlock to pass in or out unless the handle is in the OFF-position.

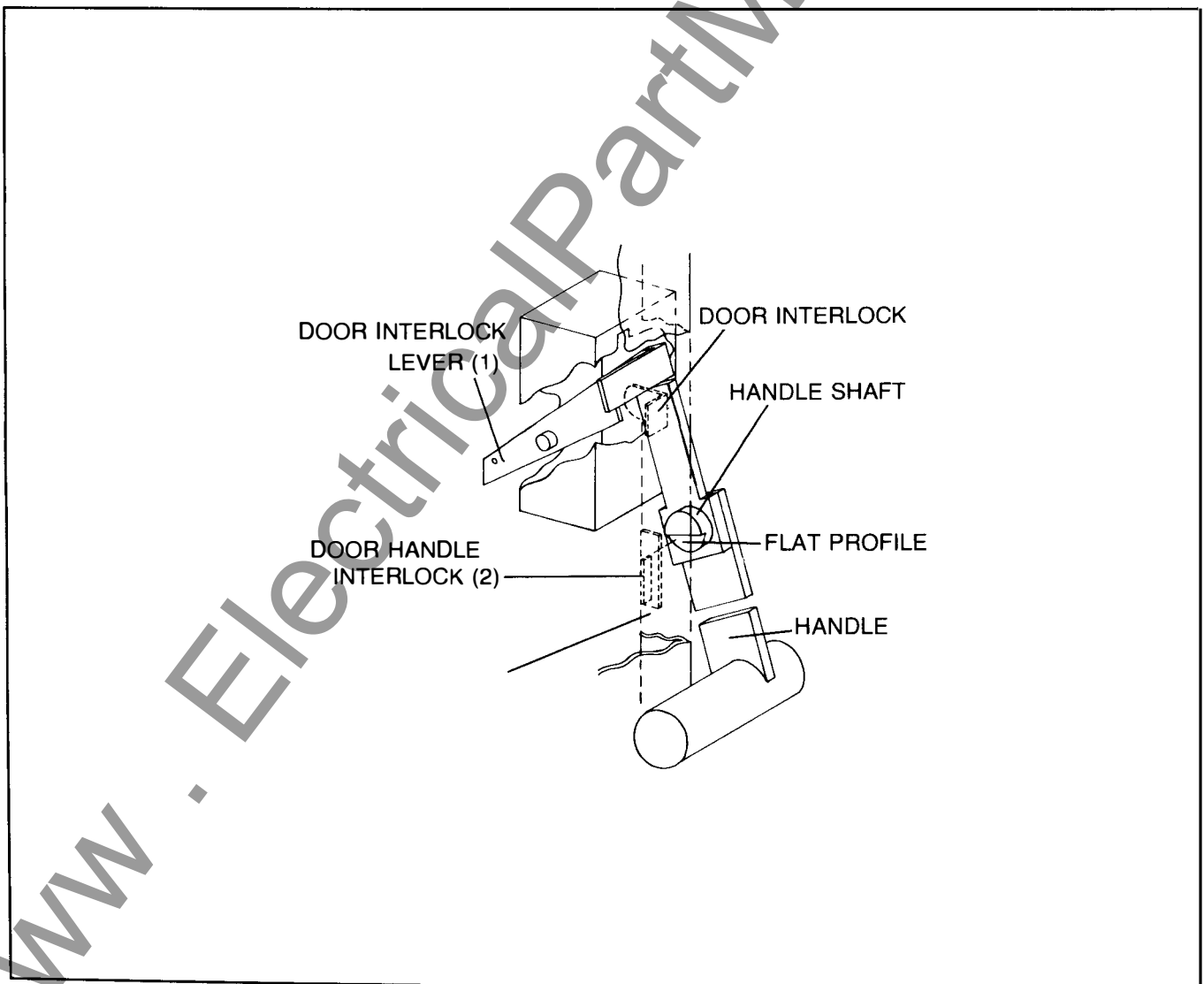

Figure 4. Door Interlocks

In Figure 5, a suggested general layout of the cell module in a typical enclosure is shown. Figures 6 and 7 then detail the necessary dimensional relationships between

the cell module, enclosure door, and interlocks. The door interlock and the door-handle interlock should be attached to the door by spot welding or similar method at the locations shown in the figures.

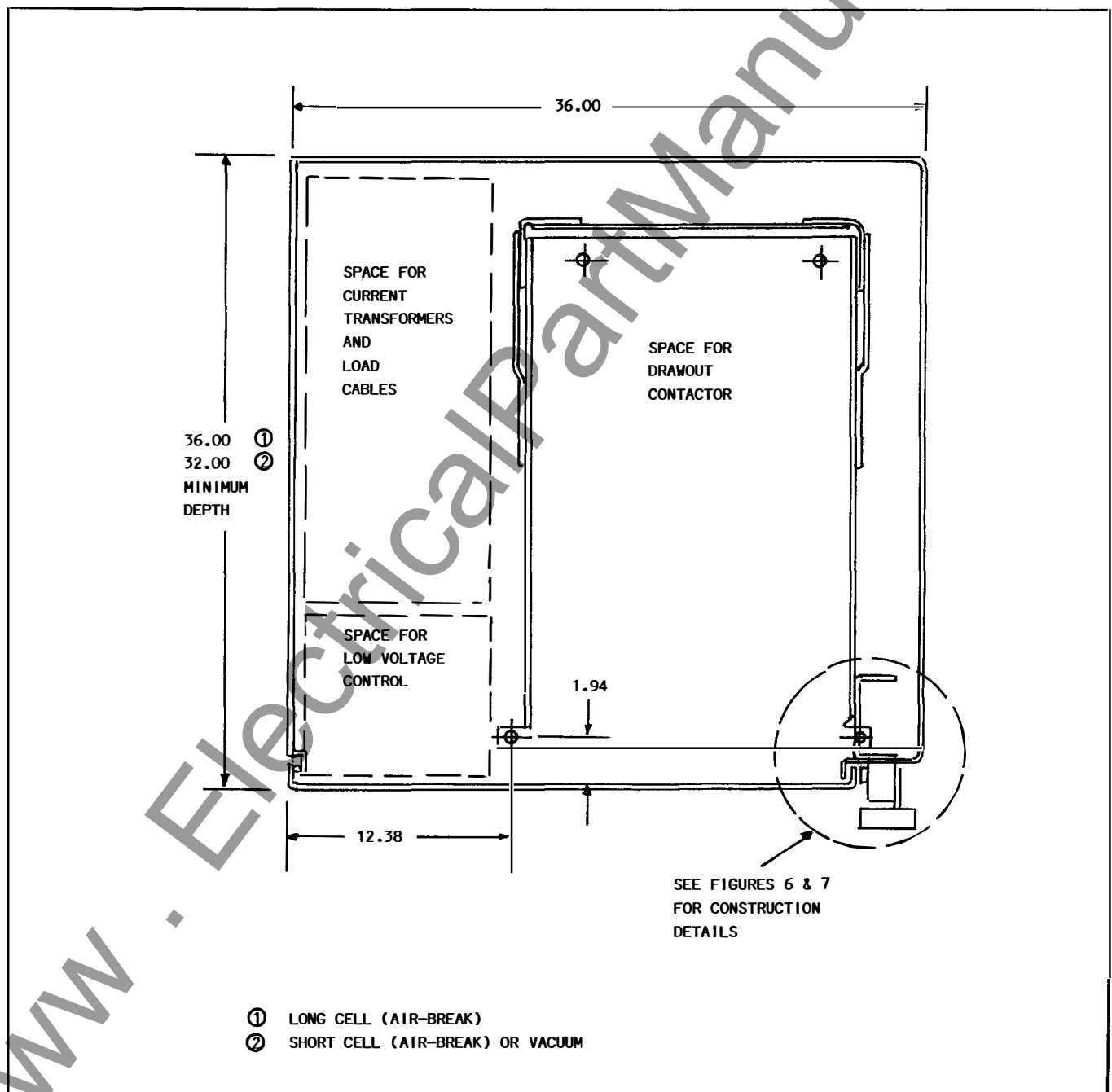

Figure 5. Typical Layout of Cell Module in Cubicle - Top View

# Installation

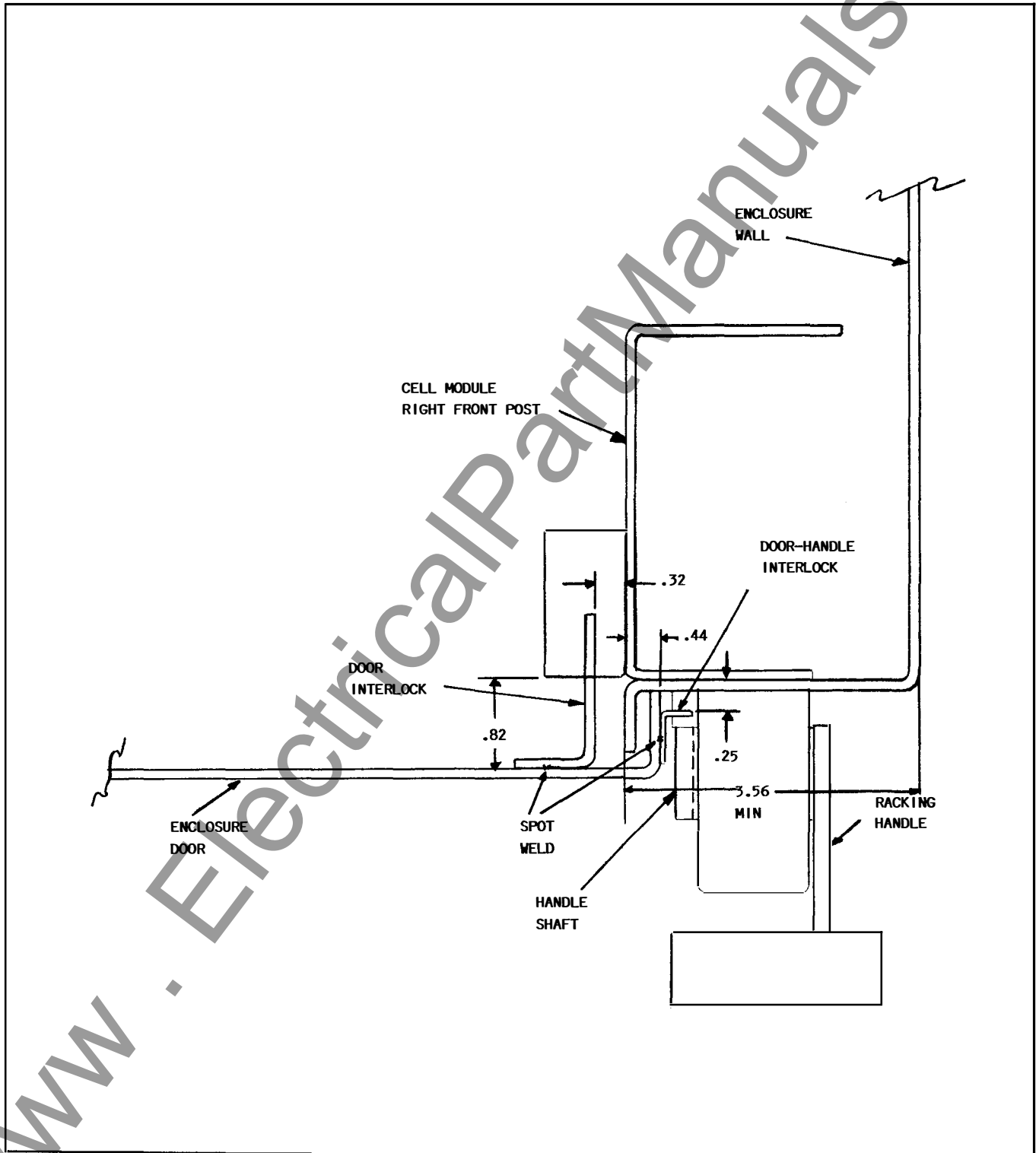

Figure 6. Door Handle and Interlock Details - Top View



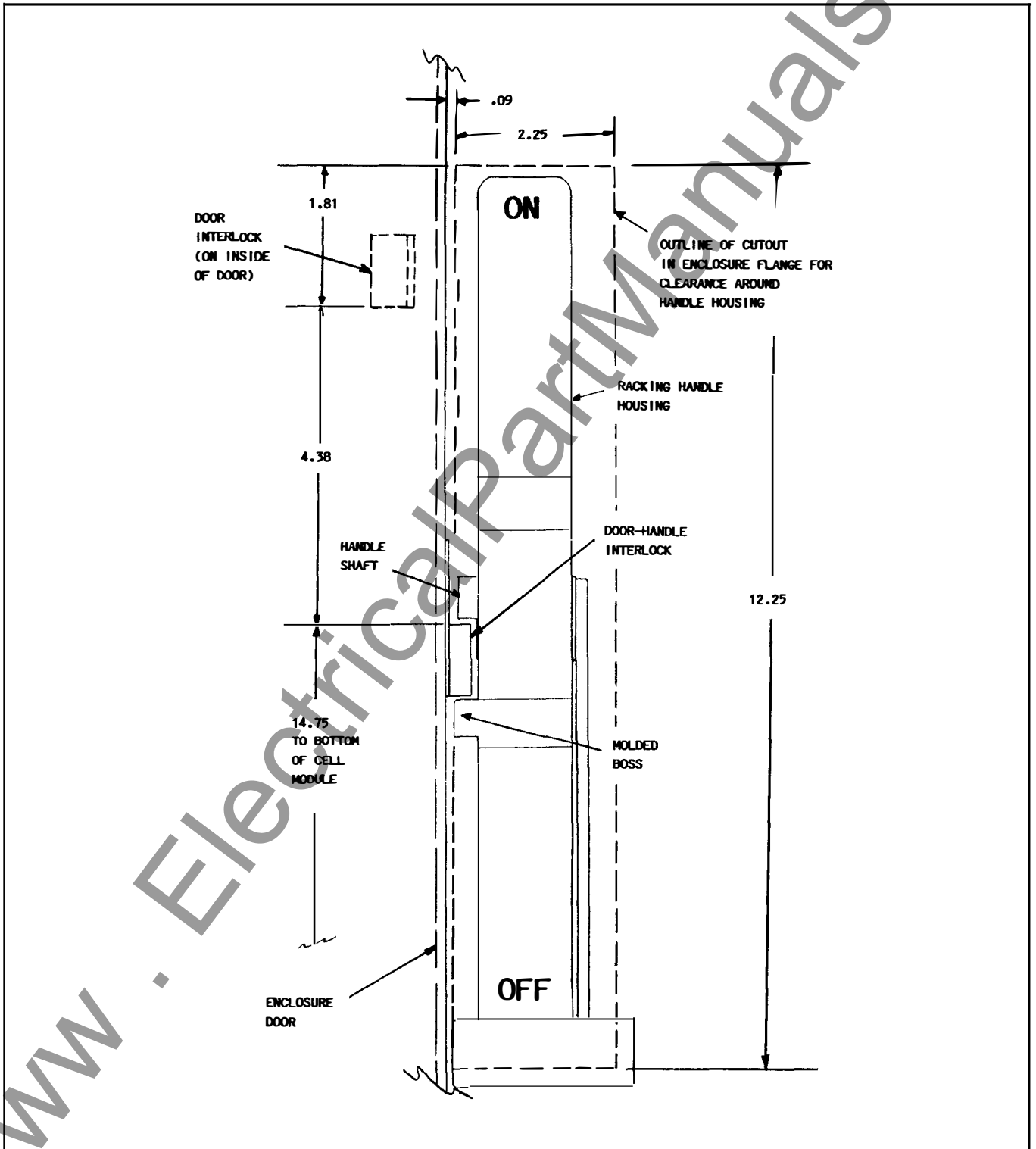

Figure 7. Door Handle and Interlock Details - Front View

# Installation

## Wiring

Typical wiring for an air-break controller is shown in Figure 8 and for a vacuum controller in Figure 9. Note that the use of solenoid 'S' drives the mechanical interlock on the cell module which prevents motion of the racking mechanism when the controller is picked up. The circuit

is designed to ensure that the solenoid is energized and the racking interlock is positively engaged before the contactor can be closed. Strict adherence to the circuit shown for solenoid 'S', contact 'S' and relay 'IR' is required to maintain the fail-safe characteristics of the interlocking scheme.

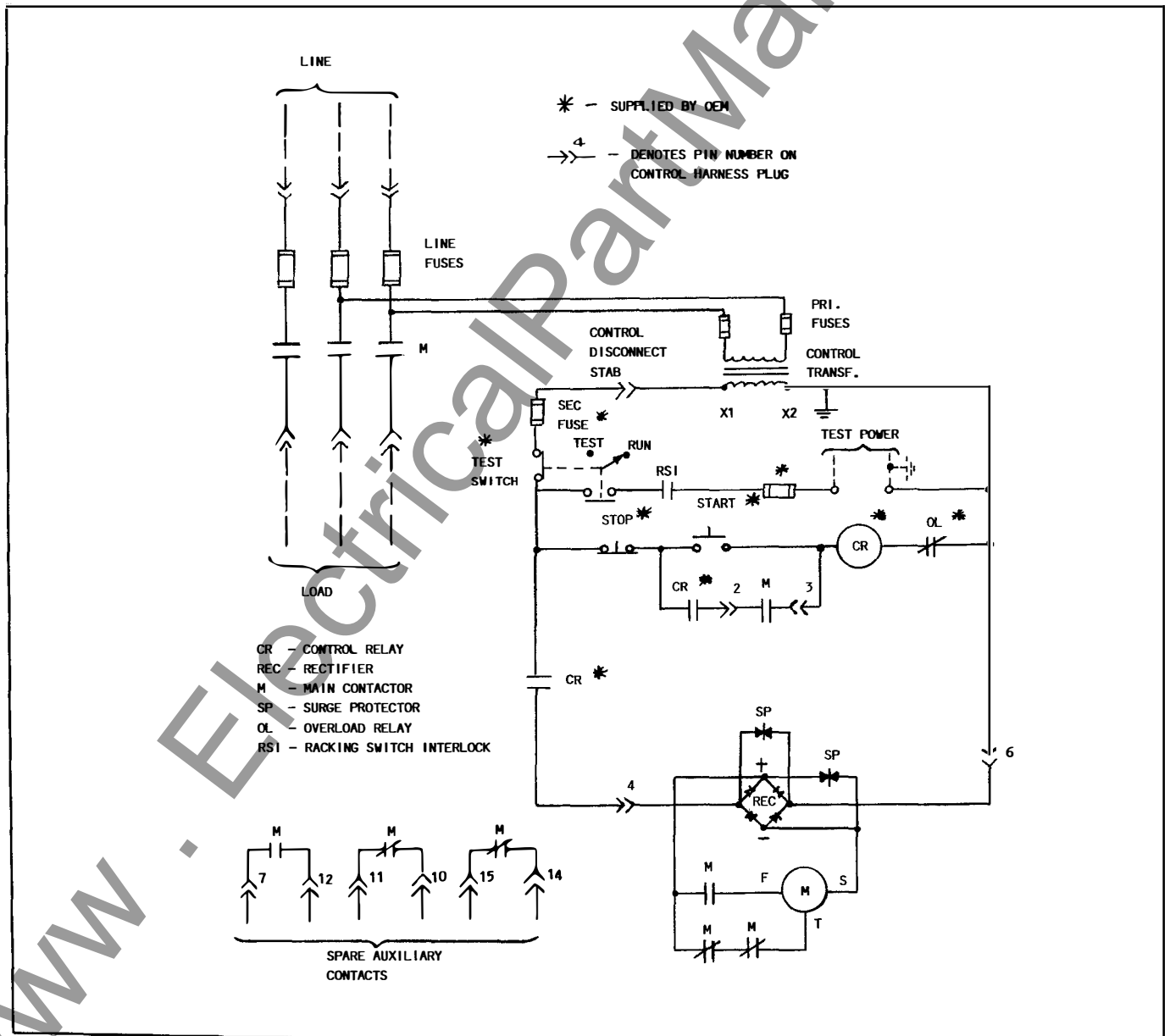

Figure 8. Typical Air-Break Controller Wiring Diagram

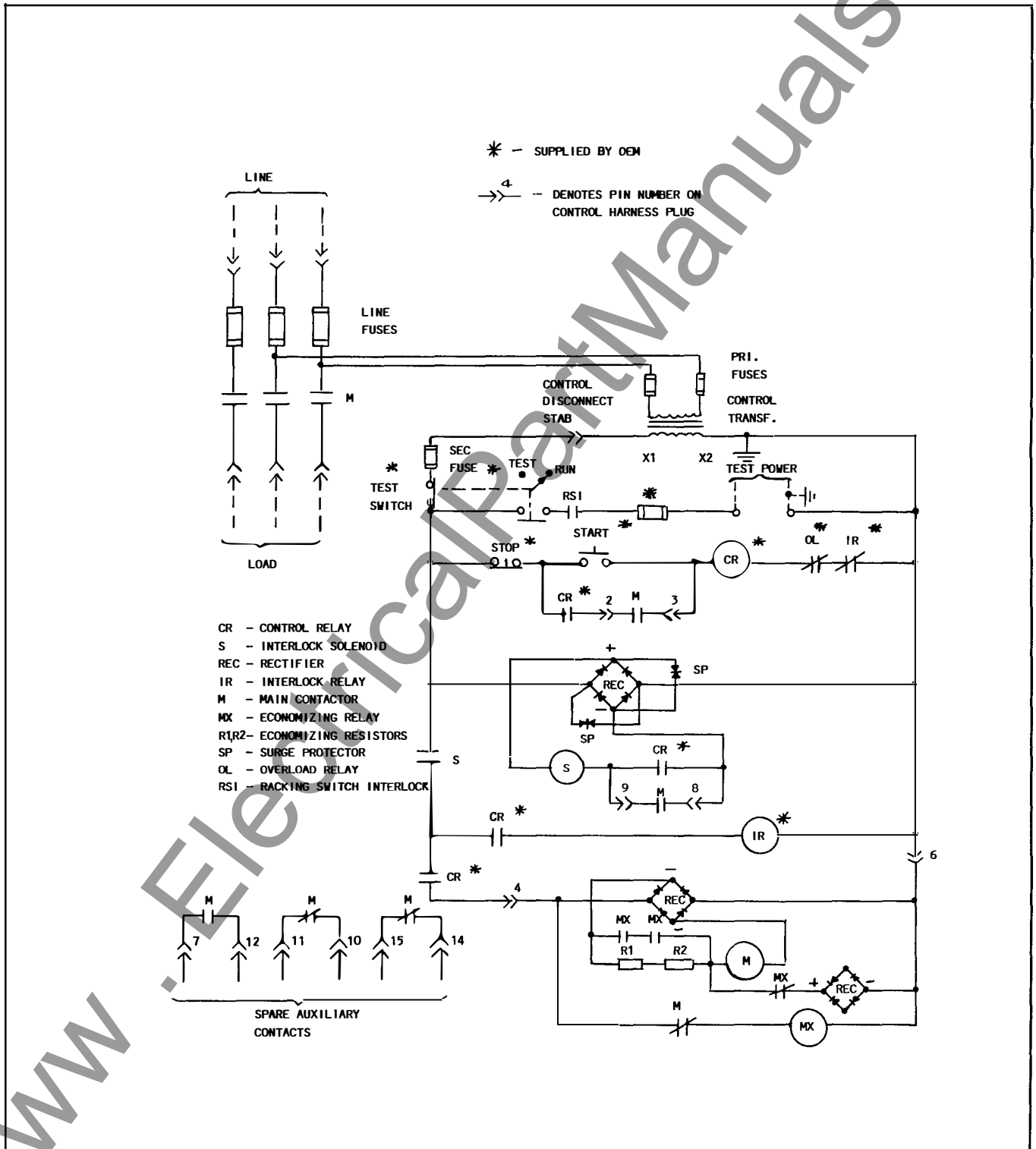

Figure 9. Typical Vacuum Controller Wiring Diagram

## Notes

---

www . ElectricalPartManuals . com

[www.ElectricalPartManuals.com](http://www.ElectricalPartManuals.com)

## Please Call Siemens Energy & Automation, Inc.

**Alabama**  
Birmingham  
(205)879-7030  
Mobile  
(205)928-0822  
Montgomery  
(205)271-4486

**Alaska**  
Anchorage  
(907)346-2489

**Arizona**  
Phoenix  
(602)944-7900

**Arkansas**  
Little Rock  
(501)224-9595

**California**  
Fresno  
(209)264-5018  
Los Angeles  
(714)979-6600  
Oakland  
(415)835-0900  
Sacramento  
(916)447-0274  
San Diego  
(619)569-8015  
San Francisco  
(415)786-9240  
Stockton  
(209)478-9596

**Colorado**  
Colorado Springs  
(719)260-0297  
Denver  
(303)694-3770  
Ft. Collins  
(303)223-2712

**Connecticut**  
Tolland  
(203)875-7372  
Wallingford  
(203)265-5003

**Florida**  
Ft. Lauderdale  
(305)484-3888  
Fort Myers  
(813)656-3605  
Jacksonville  
(904)396-9659  
Miami  
(305)592-4106  
Orlando  
(305)894-7771  
Tallahassee  
(904)386-8926  
Tampa  
(813)886-2551  
West Palm Bch  
(305)683-5185

**Georgia**  
Atlanta  
(404)458-4353  
Macon  
(912)743-8994  
Savannah  
(912)897-5049

**Hawaii**  
Honolulu  
(808)533-7135

**Idaho**  
Boise  
(208)342-6852

**Illinois**  
Chicago  
(312)330-4320  
Decatur  
(217)875-5330  
Peoria  
(309)688-8729

**Indiana**  
Evansville  
(812)422-9176  
Fort Wayne  
(219)436-1739  
Indianapolis  
(317)788-5500  
Roseland  
(219)277-7040

**Iowa**  
Davenport  
(319)359-1357  
Des Moines  
(515)223-1277

**Kansas**  
Kansas City  
(913)491-3114  
Wichita  
(316)942-1409

**Kentucky**  
Louisville  
(502)426-4647

**Louisiana**  
Baton Rouge  
(504)293-6874  
New Orleans  
(504)885-3622  
Shreveport  
(318)424-0720

**Maine**  
Portland  
(207)772-0021

**Massachusetts**  
Boston  
(508)470-3660  
Braintree  
(617)848-5770  
Peabody  
(508)532-6720  
Worcester  
(508)792-4566

**Michigan**  
Grand Rapids  
(616)247-7611  
Detroit  
(313)597-7400

**Minnesota**  
Minneapolis  
(612)835-1560

**Mississippi**  
Jackson  
(601)982-2274

**Missouri**  
Kansas City  
(913)491-3114  
St. Louis  
(314)567-3900

**Nebraska**  
Omaha  
(402)397-1940

**Nevada**  
Las Vegas  
(702)739-7900

**New Hampshire**  
Manchester  
(603)623-6264

**New Jersey**  
Iselin  
(201)321-8780  
Union  
(201)687-7672

**New Mexico**  
Albuquerque  
(505)881-1611

**New York**  
Albany  
(518)482-1619  
Buffalo  
(716)834-3815  
Fairport  
(716)223-9660  
Long Island  
(516)484-3490  
Syracuse  
((315)446-8660

**North Carolina**  
Charlotte  
(704)536-1201  
Greensboro  
(919)373-1849  
Raleigh  
(919)782-3365

**North Dakota**  
Bismarck  
(701)258-9555  
Fargo  
(701)293-7709

**Ohio**  
Cincinnati  
(523)793-3880  
Cleveland  
(216)642-0701  
Columbus  
(614)766-2204  
Dayton  
(513)296-2289  
Toledo  
(419)865-8823

**Oklahoma**  
Oklahoma City  
(405)943-9156  
Tulsa  
(918)665-1806

**Oregon**  
Eugene  
(503)683-2111  
Portland  
(503)636-6700

**Pennsylvania**  
Erie  
(814)456-5998  
Philadelphia  
(215)825-5300  
Pittsburgh  
(412)257-0090  
York  
(717)755-0942

**Rhode Island**  
Providence  
(401)272-2888

**South Carolina**  
Columbia  
(803)254-7095  
Greenville  
(803)288-3490

**Tennessee**  
Chattanooga  
(615)267-7412  
Johnson City  
(615)282-2718  
Knoxville  
(615)690-5172  
Memphis  
(901)761-2123  
Nashville  
(615)367-9403

**Texas**  
Austin  
(512)443-7822  
Dallas  
(214)247-4481  
Fort Worth  
(817)735-1947  
Houston  
(713)681-4900  
McAllen  
(512)687-2072  
San Antonio  
(512)824-7421

**Utah**  
Salt Lake City  
(801)272-2090

**Virginia**  
Richmond  
(804)288-8311  
Roanoke  
(703)982-2776  
Virginia Beach  
(804)481-2440

**Washington**  
Seattle  
(206)828-6600  
Spokane  
(509)325-2582

Washington, DC  
(301)459-2044

**Wisconsin**  
Milwaukee  
(414)258-8535

**Canada**  
Mississauga,  
Ontario  
(416)673-1995  
Pointe Claire,  
Quebec  
(514)695-7300  
Vancouver  
British Columbia  
(604)321-8687

**International**  
TLX:822024SEA  
IBU UF  
FAX:(404)751-2496