

RENEWAL PARTS



IC302A HIGH VOLTAGE CONTACTORS

IC302AA2----200A-2300V

AB2----200A-4800V

AC2----200A-5000V

IC302AA4----400A-2300V

AB4----400A-4800V

AC4----400A-5000V

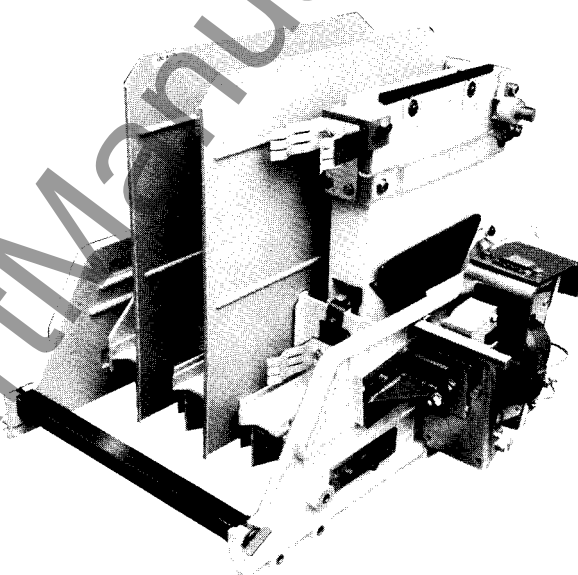
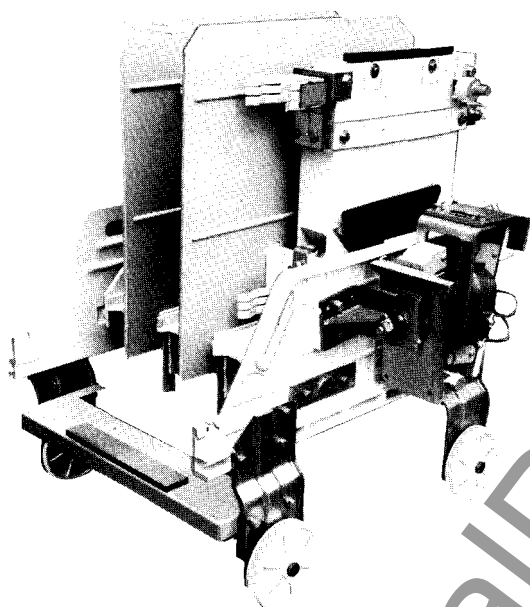

PARTS RECOMMENDED FOR NORMAL STOCK

NOTE: The current is identified by the number following the voltage letter in the IC designation.

EXAMPLE: IC302AA4AA1A47AA2A is a 400 amp. contactor.

Ref. No.	No. Req'd for IC302A-----		Catalog Number	Description
	200 Amp	400 Amp		
1	1	1	-----	Operating coils (see table on page 2)
27	3	3	2416875P1	Compression spring for moving contact
28	3	3	167A8898G1	Main moving contact assembly
31	3	-	188A5535G2	Shunt for moving contact
31	-	3	188A5535G1	Shunt for moving contact
34	3	3	167A8898G1	Main stationary contact
62	78	78	104B9931P1	Arc barrier plate (IC designations AA thru AD only)
62	36	36	177B3253P3	Arc barrier plate (IC designations BA thru BD only)
62	36	36	177B3253P4	Arc barrier plate (IC designations BA thru BD only)
87	12	12	125A4278P3	Contact finger for stab-on (IC designations AA, AB, AD, BA, BB, and BD only)
90	3	3	174AA4422P1	Spring for stab-on finger

When ordering renewal parts, give quantity, catalog number, description of each item required, and complete nameplate reading.

GENERAL  ELECTRIC

IC302A HIGH VOLTAGE CONTACTORS

REF. NO. 1 - OPERATING COILS - 1 Required

NOTE: The operating coil is identified by the number following the armature in the IC designation.

EXAMPLE: IC302AA4AA1A47AA2A requires coil No. 47, Cat. No. 1D300G124.

Coil No.	Catalog Number	Coil No.	Catalog Number	Coil No.	Catalog Number	Coil No.	Catalog Number
2	1D300G102	15	1D300G103	30	1D300G125	47	1D300G124
3	1D300G103	16	1D300G104	31	1D300G126	48	1D300G134
4	1D300G123	17	1D300G115	32	1D300G127	49	1D300G135
5	1D300G105	18	1D300G116	33	1D300G108	50	1D300G136
6	1D300G106	19	1D300G117	34	1D300G122	51	1D300G133
7	1D300G107	22	1D300G120	35	1D300G128	52	1D300G135
8	1D300G108	23	1D300G113	38	1D300G129	53	1D300G145
9	1D300G109	24	1D300G121	39	1D300G107	54	1D300G138
10	1D300G110	25	1D300G122	40	1D300G103	55	1D300G144
11	1D300G111	26	1D300G123	41	1D300G130	56	1D300G139
12	1D300G112	28	1D300G123	42	1D300G131	57	1D300G140
13	1D300G113	29	1D300G124	46	1D300G133	58	1D300G151
14	1D300G114						

LATCH ASSEMBLY ONLY - 1 Required

NOTE: The latch assembly is identified by the form letter following the coil number in the IC designation.

EXAMPLE: IC302AA4AA1A47AB3A requires Form Letter AB, Cat. No. 136C1754G9.

Form Letter	Catalog Number	Form Letter	Catalog Number	Form Letter	Catalog Number	Form Letter	Catalog Number
AB*	136C1754G9	AD*	136C1754G8	AF	136C1754G7	AH	136C1754G9
AC*	136C1754C7	AE	136C1754G5	AG	136C1754G8		

* Wire harness (Cat. No. 7128R73) must be ordered separately, if used.

LATCH AND TRIP BAR ASSEMBLIES - 1 Required

NOTE: The latch and trip bar assemblies are identified by the form letter following the coil number in the IC designation.

EXAMPLE: IC302A4A1A47AN3A requires Form Letter AN, Latch Assy Cat. No. 136C1754G9 and Trip Bar Assy Cat. No. 918D605G2.

Form Letter	Latch Assy. Cat. No.	Trip Bar Assy. Cat. No.	Form Letter	Latch Assy. Cat. No.	Trip Bar Assy. Cat. No.
AM	-----	918D605G1	AS†	136C1754G7	918D605G3
AN∅	136C1754G9	918D605G2	AT†	136C1754G8	918D605G3
AP∅	136C1754G7	918D605G2	AU†	136C1754G9	918D605G3
AR∅	136C1754G8	918D605G2	AV†	136C1754G1	918D605G3

∅ With wire harness.
† Without wire harness.

TRIP SOLENOID FOR LATCH ASSY (1 Required)

NOTE: The solenoid is identified by the number following the latch assembly form letter in the IC designation.

EXAMPLE: IC302AA4A47AB3A requires Solenoid No. 3, Cat. No. CR9500A201CM7A.

Solenoid Form No.	Solenoid Catalog Number	Solenoid Coil Catalog Number	Rectifier Catalog Number	Solenoid Form No.	Solenoid Catalog Number	Solenoid Coil Catalog Number	Rectifier Catalog Number
3	CR9500A201CM7A	15D2G55	-----	53	CR9500A201CM2A	15D2G2	-----
4	CR9500A201CM8A	15D2G69	-----	54	CR9500A201CM3A	15D2G3	-----
5	CR9500A201CM3A	15D2G80	-----	55	CR9500A201CM7A	15D2G7	-----
6	CR9500A201CM5A	15D2G88	-----	75	CR9500A201CM9A	15D2G14	IC3500A403C2
				76	CR9500A201CM11A	15D2G3	IC3500A403C6

IC302A HIGH VOLTAGE CONTACTORS

GEF-4551

NOTE: The current is identified by the number following the voltage letter in the IC designation.

EXAMPLE: IC302AA4AA1A47AA2A is a 400 amp. contactor.

Ref. No.	No. Req'd for IC302A-		Catalog Number	Description
	200 Amp	400 Amp		
2	1	1	918D625P1	Frame, right-side
2A	1	1	157C8183P1	Frame, left-side
3	1	1	233B523G6	Magnet frame for operating coil
4	2	2	284A962P2	Pole shader
5	1	1	218A5593G1	Coil holder
6	1	1	188A5536P1	Clamp for magnet frame, bottom
7	1	1	188A5536P2	Clamp for magnet frame, top
	1	1	199A7822P1	Plate for lower clamp
	2	2	N22P25032B6	Bolt fastening clamp to magnet frame (3/8-16, 2 in. hex. hd, pro. fin.)
	2	2	218A6880P1	Washer for bolt
	1	1	139B7623G1	Armature assembly, complete with armature, bracket and fulcrum
9	1	1	233B523G2	Armature
10	1	1	139B8161G1	Armature bracket
11	1	1	284B964P2	Fulcrum
12	2	2	N22P25014B6	Bolt fastening fulcrum to bracket
13	2	2	PFC #41439	Bolt fastening armature bracket to shaft
	2	2	PFC #43685	Lock washer for Ref. 13
14	1	1	139B8162G1	Armature stop
15	1	1	188A5553P1	Stop screw for armature stop
16	2	2	577A177P2	Mounting bolt for stop assembly
17	2	2	188A5542P1	Terminal for operating coil
18	2	2	N144P16010B6	Screw with lock washer for terminal (10-32, 5/8 in., pan hd, pro. fin.)
	2	2	8617022P1	Terminal clamp
	2	2	N144P16008B6	Screw with lock washer for mounting terminal clamp
19	2	2	188A5527G1	Stub shaft assembly
21	4	4	577A176P2	Mounting bolt for stub shaft assembly
22	2	2	286A113P27	Bolt for end of stub shaft
23	2	2	188A5537G1	Bearing plate assembly for moving contact shaft
	2	2	181A4108P2	Collar for end of moving contact shaft
	4	4	245A6128P1	Set screw for collar
24	1	-	187B5651G1	Shaft assembly, complete, with shaft, moving contacts, support, shunt, spring and adjusting screw
24	-	1	139B7622G1	Shaft assembly, complete, with shaft, moving contacts, support, shunt, spring and adjusting screw
	1	1	685D924G1	Main shaft
25	3	3	188A5539P1	Pin for moving contact support
26	6	6	N22P21012B6	Bolt fastening moving contact support to shaft
27	3	3	2416875P1	Compression spring for moving contact
28	3	3	167A8898G1	Moving contact assembly
29	3	3	139B8165G1	Support for moving contact
30	3	3	188A5551P1	Adjusting screw for contact support
31	3	-	188A5535G2	Shunt for moving contact
31	-	3	188A5535G1	Shunt for moving contact
32	3	3	577A177P4	Bolt fastening moving contact and shunt to support
33	3	3	N22P23016B6	Screw for contact support to position shunt (5/16-16, 1 in. hex. hd, pro. fin.)
34	3	3	167A8898G1	Stationary contact
35	3	3	139B8171G1	Clip for arcing horn
36	3	-	286A113P44	Bolt for clip
36	-	3	577A177P2	Bolt for clip
37	1	1	685D952P1	Base
	3	3	N22P23022B6	Bolt fastening blowout coil to base
	3	3	577A328P2	Tee nut for bolt
39	3	-	233A2386G1	Blowout coil
39	-	3	167A8581G1	Blowout coil
	3	3	139B8170G1	Core for blowout coil
40	3	3	194A1454P2	Insulation tube for core
	2	-	233A2387P1	Back-up strip for blowout coil
42	6	6	PFC #40265	Insulation washer for pole pieces
43	3	-	171B3144G1	Pole piece, left-hand
43	-	3	139B8168G1	Pole piece, left-hand
44	3	-	171B3144G2	Pole piece, right-hand
44	-	3	139B8168G2	Pole piece, right-hand
45	6	6	N647P23012C6	Bolt fastening pole pieces to core (5/16-18, 3/4 in., button hex. hd)
	6	6	205A7742P105	Washer for Ref. 45

IC302A HIGH VOLTAGE CONTACTORS

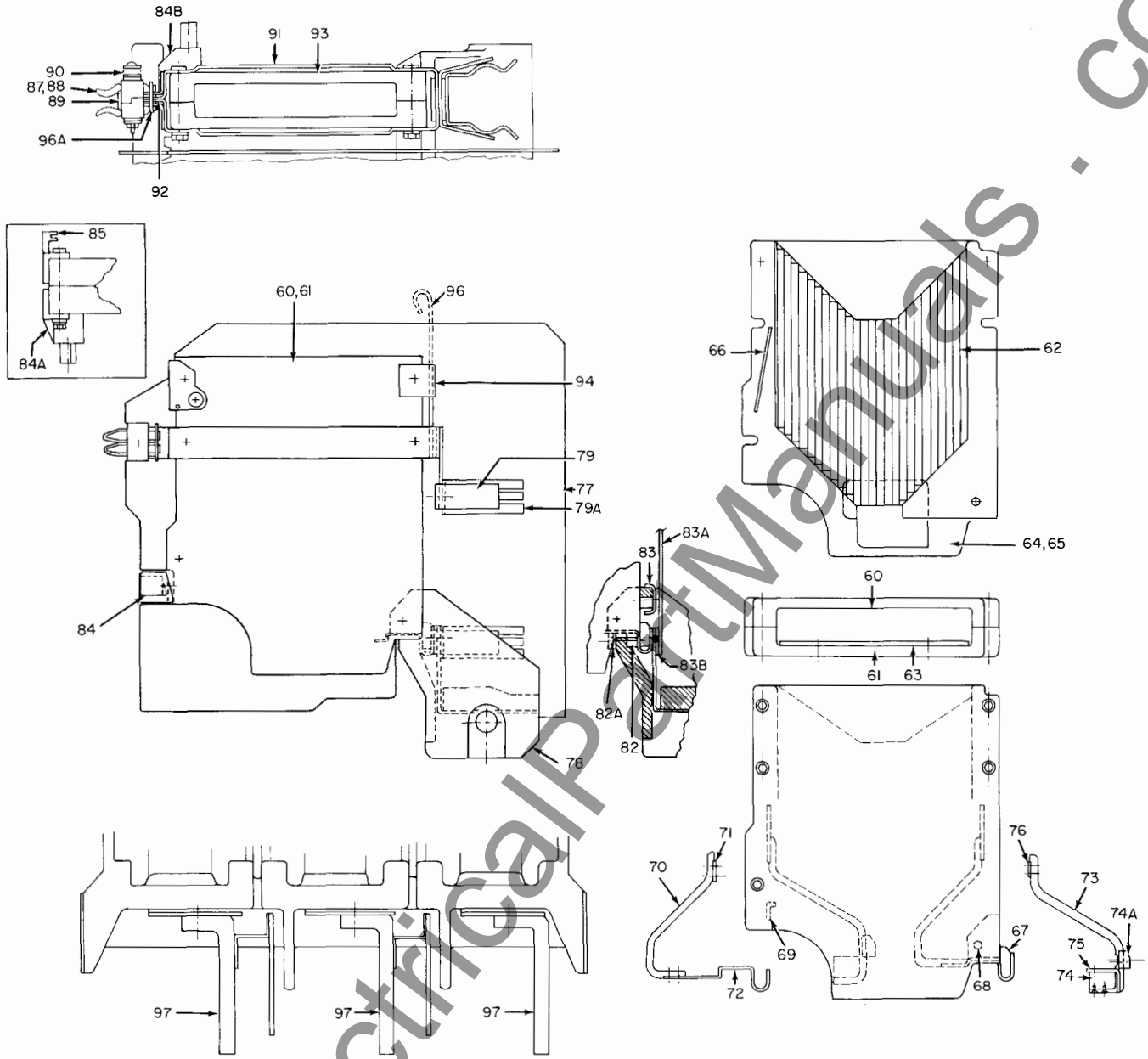

Ref. No.	No. Req'd for IC Designation								Catalog Number	Description
	AA	AB	AC	AD	BA	BB	BC	BD		
96A	3	3	-	3	3	3	-	3	125A4280P1	Retainer
97	3	1	-	1	3	1	-	1	149B1754G8	Intermediate stab assembly
	-	2	-	2	-	2	-	2	149B1754G7	Intermediate stab assembly
	3	3	-	3	-	3	-	3	188A5686P2	Stab assembly
	1	1	1	1	1	1	1	1	195B6267G1	Wheel assembly
98	4	4	4	4	4	4	4	4	149B1762P1	Wheel
99	4	4	4	4	4	4	4	4	259A5525P1	Wheel support
100	1	1	1	1	1	1	1	1	259A5546G1	Spacer assembly
101	1	1	1	1	1	1	1	1	259A5545P2	Fastener assembly
102	4	4	4	4	4	4	4	4	162A2894P1	Wheel bolt
103	2	2	2	2	2	2	2	2	151A4894P1	Gasket
104	2	2	2	2	2	2	2	2	162A4950P32	Spacer
105	1	1	1	1	1	1	1	1	188A5532G3	Handle
	2	2	2	2	2	2	2	2	188A5688G2	Thumb screw

GENERAL ELECTRIC COMPANY • COMPONENT AND DEVICES SALES
 DRIVE SYSTEMS DEPARTMENT • SALEM, VA 24153

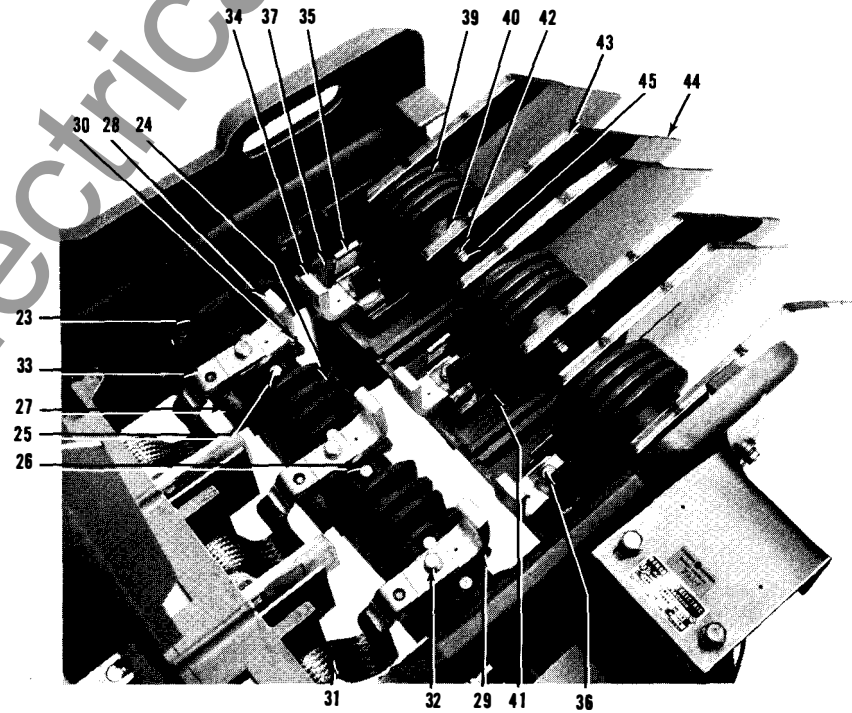
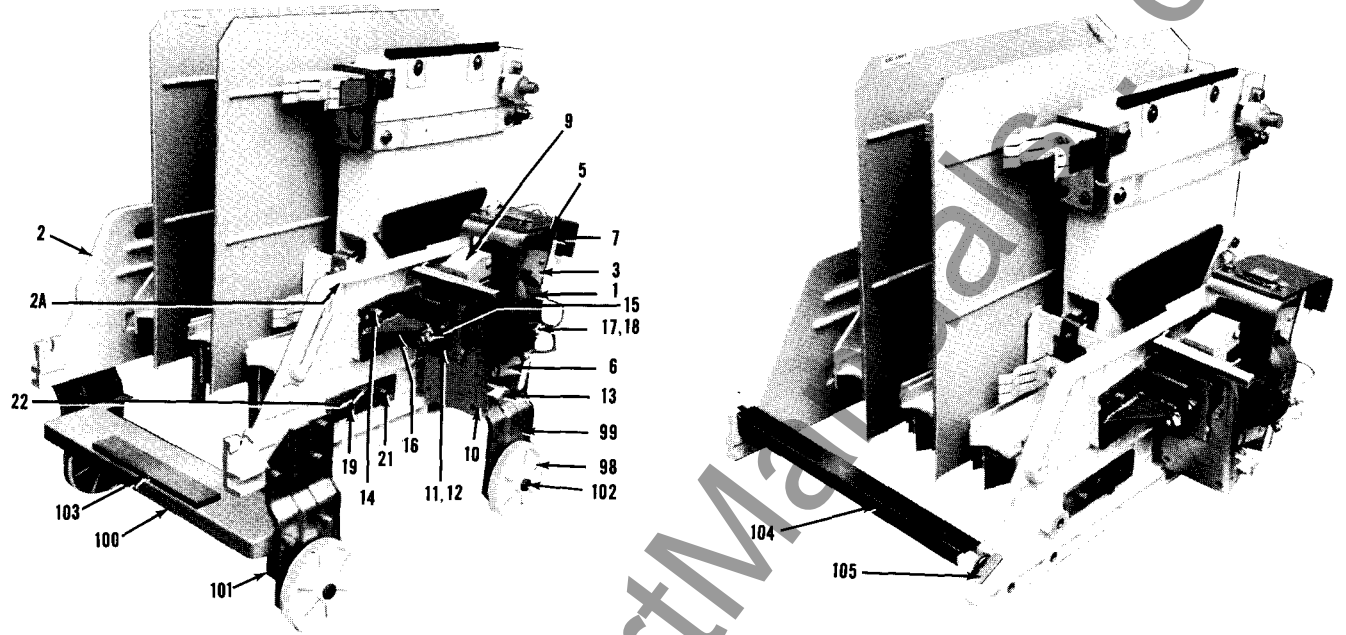

IC302A HIGH VOLTAGE CONTACTORS

GEF-4551

NOTE: The arc chute and fuse base assembly is determined by the ninth and tenth digit in the IC designation.

EXAMPLE: IC302AA4-AA1A47AA requires arc chute and fuse base assembly designation AA. Listed below are the different designation and voltage ratings.

ARC CHUTE AND FUSE BASE ASSEMBLY

- AA - 2300 VOLT, FUSE, STABS, NON U.L.
- AB - 4800 VOLT, FUSE, STABS, NON U.L.
- AC - 5000 VOLT, NO FUSE, NO STABS, NON U.L.
- AD - 5000 VOLT, SHORTING BAR, STABS, NON U.L.
- BA - 2300 VOLT, FUSE, STABS, U.L. FOR LIMITAMP ONLY
- BB - 4800 VOLT, FUSE, STABS, U.L. FOR LIMITAMP ONLY
- BC - 5000 VOLT, NO FUSE, NO STABS, U.L. FOR LIMITAMP ONLY
- BD - 5000 VOLT, SHORTING BAR, STABS, U.L. FOR LIMITAMP ONLY

Ref. No.	No. Req'd for IC Designation								Catalog Number	Description
	AA	AB	AC	AD	BA	BB	BC	BD		
	3	3	3	3	-	-	-	-	177B8794G1	Arc chute assembly
	-	-	-	-	3	3	3	3	177B8794G8	Arc chute assembly
60	3	3	3	3	3	3	3	3	501D196P1	Arc chute side, left
61	3	3	3	3	3	3	3	3	501D196P2	Arc chute side, right
62	78	78	78	78	-	-	-	-	104B9931P1	Arc barrier plate
62	-	-	-	-	36	36	36	36	177B3253P3	Arc barrier plate
62	-	-	-	-	36	36	36	36	177B3253P4	Arc barrier plate
63	3	3	3	3	3	3	3	3	149B1784G2	Barrier holder
64	3	3	3	3	3	3	3	3	177B3273P1	Chute insert, left
65	3	3	3	3	3	3	3	3	177B3273P2	Chute insert, right
66	3	3	3	3	3	3	3	3	245A1235P1	Deflector
	3	3	3	3	3	3	3	3	151A7164P10	Mica tubing
67	3	3	3	3	3	3	3	3	139B8999G1	Chute block assembly
68	6	6	6	6	6	6	6	6	577A177P5	Mounting bolt for chute block
69	3	3	3	3	3	3	3	3	188A5524G1	Nut plate
	-	-	-	-	-	-	-	-	245A4320P1	Shims (as required) (for tight bundle of barriers)
	-	-	-	-	-	-	-	-	245A4320P2	Shims (as required) (for tight bundle of barriers)
	3	3	3	3	3	3	3	3	194B8338G1	Arcing horn assembly, front
70	3	3	3	3	3	3	3	3	194B8340P1	Main arcing horn
71	3	3	3	3	3	3	3	3	259A8786P1	Spacer
72	3	3	3	3	3	3	3	3	259A5550P1	Hooked shaped end plate
	6	6	6	6	6	6	6	6	N57P16008C6	Screw fastening spacer or end plate to horn (10-32, 1/2 in. pan hd, pro. fin.)
	3	3	3	3	3	3	3	3	194B8338G2	Arcing horn assembly, rear
73	3	3	3	3	3	3	3	3	194B8340P2	Main arcing horn
74	3	3	3	3	3	3	3	3	259A5543P1	Block
74A	3	3	3	3	3	3	3	3	259A5543P2	Block
75	3	3	3	3	3	3	3	3	259A8786P1	Spacer
76	3	3	3	3	3	3	3	3	259A8786P2	Spacer
77	2	2	2	2	2	2	2	2	139B7619P1	Barrier between arc chutes
78	1	1	1	1	1	1	1	1	158C1805G1	Fuse base and shunt plate assembly
79	3	3	-	-	3	3	-	-	188A5539P1	Spring support
79A	3	3	-	-	3	3	-	-	188A5534P1	Fuse clip
80	3	3	3	3	3	3	3	3	139B8179P12	Ground strap
81	6	6	-	-	6	6	-	-	N22P23024B6	Mounting screw for ground strap, fuse clip and spring support (5/16-18, 1 1/2 in. hex, pro. fin.)
82	3	3	3	3	3	3	3	3	139B8179P3	Nut block
82A	3	3	3	3	3	3	3	3	188A5292P1	Support for nut block
83	3	3	3	3	3	3	3	3	194A7125P1	Saddle
83A	-	-	3	3	-	3	3	3	205A9613P6	Bus spacer
83B	-	-	-	3	-	3	-	3	205A9613P5	Shorting bar
	3	3	9	9	3	9	9	9	577A177P5	Mounting screw for saddle, bus spacer and shorting bar
84	1	1	1	1	1	1	1	1	116C9907P1	Chute tie bar
	1	1	-	1	1	1	-	1	194A6900G2	Shaft assembly for left-hand arc chute assembly
	1	1	-	1	1	1	-	1	194A6900G1	Shaft assembly for right-hand arc chute assembly
85	1	1	-	1	1	1	-	1	116C9908P4	Operating shaft left-half for shaft assembly
86	1	1	-	1	1	1	-	1	116C9908P3	Operating shaft right-half for shaft assembly
87	12	12	-	12	12	12	-	12	125A4278P3	Contact finger for stab-on
88	12	12	-	12	12	12	-	12	125A4279P1	Spacer for stab-on finger
89	3	3	-	3	3	3	-	3	125A4281P1	Retainer
90	3	3	-	3	3	3	-	3	174A4422P1	Spring for stab-on finger
91	3	3	-	3	3	3	-	3	139B8172P12	Connection strap
92	6	6	-	6	6	6	-	6	233A2394P2	Spacer between connection strap and backup strap
93	3	3	-	3	3	3	-	3	139B8172P2	Backup strap
94	3	3	-	3	3	3	-	3	273A2686G1	Bracket
95	3	3	-	3	3	3	-	3	245A8015P1	Copper strip
96	3	3	-	3	3	3	-	3	273A2687P1	Fuse bracket (if used)
	6	6	-	6	6	6	-	6	577A176P2	Mounting screw for fuse bracket
	3	3	-	3	3	-	-	-	188A5558P2	Nut plate