



**Instruction Book**

**M-2001C (BASE-R)  
Tapchanger Control**

**BECKWITH**  **CO. INC.**  
**ELECTRIC**

# Digital Tapchanger Control M-2001C

## Digital Tapchanger Control for Transformers and Regulators

- LTC transformer, substation regulator, and line regulator control provides reliable operation with expanded capabilities
- Available in four models; Comprehensive, Base-T, Base-RS and Base-R
- Adapter panels to retrofit popular industry tapchanger controls
- Ten on-board communication protocols, including IEC-61850
- Count Window - Works even with noisy operation counter contacts
- Field-updatable programming
- Reverse power detection/operation
- Demand metering/Data Logging with Date/Time Stamp
- Entire control configuration prints out from TapTalk®
- SCAMP™ (SCADA Controlable Auto/Manual Pushbutton) Adapter Panel Auto/Manual Switch State can be changed by a SCADA command pushbutton
- Overcurrent protection
- LDC with R & X or Z-compensation
- Increased Bandwidth to 10 Volts
- Ethernet port optional
- Supports terminal mode for modem communications in TapTalk
- Transformer paralleling by circulating current, external master-follower circuitry, or  $\Delta$ VAR™ methods
- Standard LCD display (rated -20 to +70 degrees Celsius.) Vacuum Fluorescent display optionally available (rated -40 to +80 degrees Celsius.)
- Optional Control Power Backup Input for Fiber Optic loop-through communication
- M-2829 TapPlot™ for Windows™ Analysis Software allows the plotting, printing and analysis of Tap Information



*Comprehensive Model Shown*

## Comprehensive Version Features

The Comprehensive version includes all M-2001C features and can be used for LTCs or regulators where SCADA communications are desired.

- Adjustable Bandcenter
- Adjustable Bandwidth
- Line Drop Compensation, R and X Compensation
- Time Delay, Definite and Inverse
- InterTap Time Delay
- Selectable Outputs, Continuous or Pulsed
- Reverse Power Operation, for Single-Phase Regulator applications
- CT to VT Phasing Correction
- Real-Time Metering of measured and calculated parameters
- Demand Metering with selectable time interval
- Drag Hands Operation
- Adjustable Line Overcurrent Tapchange Inhibit
- Voltage Limits
- Tap Position Limits
- Runback
- Three independent Voltage Reduction Steps
- Sequential and Non-Sequential Operation
- VT Ratio Correction
- Self-Test Alarm Output Contacts
- User Programmable Alarm Contacts
- Tap Position Knowledge by "Keep Track" method
- Operations Counter
- Resettable Operations Counter
- Harmonic Analysis through TapTalk®
- Tap Position Record
- Auto/Off/Manual Switch Status
- A or B Regulator Type Selection
- Alarm Contact Outputs (2)
- Control Voltage Input
- Motor Power Input
- Line Current Input
- Raise Output
- Lower Output
- 20 Character by 2 Row LCD Display
- M-2029A TapTalk Communications Software
- M-2829 TapPlot™ Tap Analysis Software
- Adapter Panel Auto/Manual Switch Type Selection
- Front RS-232 Communications Port COM2
- External Inhibit of Auto Tapchange
- Circulating Current Paralleling Method
- Tap Position Knowledge by Current Loop Method
- Front Panel LEDs for Out-of-Band **Raise**, Out-of-Band **Lower**, Reverse Power Flow **Rev Pwr** Detected, CPU **OK**, Line Drop Compensation **LDC** In Effect, Voltage Reduction **V/RED** in Effect, Auto Operation Block **MANUAL**, SCADA Control blocked **LOCAL** and Com1 **TX** and **RX**.
- Circulating Current Input
- Voltage Reduction 1 & 2 Inputs (Binary) (3 Steps Total)
- Neutral Position Detect (Binary)
- Counter Input (Binary)
- Seal-in/Switch Status Input (Binary)
- Non-Sequentail/SCADA Block Input (Binary)
- Seal-in Output
- COM1 (top) RS-232, RS-485 and Fiber Optics
- Communication Protocols include BECO 2200, BECO 2179, Cooper 2179, Cooper 2179A, GP-2179, GP DNP3.0, DNP3.0, AL PWR DNP 3.0, MODBUS, UCA 2.0, and IEC-61850 (when used with the optional ethernet port)

## Comprehensive Optional Features

- Paralleling  $\Delta$ VAR™ Methods
- Vacuum Fluorescent Display(rated –40 to +80 degrees Celsius.)
- Ethernet Port COM3 (10 Mbps) is available through an RJ-45 jack on the top of the control. This port supports DNP over TCP/IP, BECO 2200 over TCP/IP, MODBUS over TCP/IP, and IEC-61850 over TCP/IP
- Control Power Back-Up Input – input (+12 V dc) for backup of Fiber Optic loop-through communication

## Comprehensive Accessories

- M-2025C Current Loop Interface Module-Current-To-Voltage analog converter for tap position sensors
- M-2026 AC-DC Control Power Backup Supply
- M-2027 Control Power Backup Supply–AC Only
- M-2948 Tap Position Sensor - measures a 0° to 288° rotation
- M-2949 Tap Position Sensor - measures a 0° to 320° rotation

## Base-T Version Features

The Base-T version of the M-2001C is designed for transformers. It uses one COMM port (Com2) for communications.

- Adjustable Bandcenter
- Adjustable Bandwidth
- Line Drop Compensation, R and X Compensation
- Time Delay, Definite and Inverse
- InterTap Time Delay
- Selectable Outputs, Continuous or Pulsed
- Reverse Power Operation, for Single-Phase Regulator applications
- CT to VT Phasing Correction
- Real-Time Metering of measured and calculated parameters
- Demand Metering with selectable time interval
- Drag Hands Operation
- Adjustable Line Overcurrent Tapchange Inhibit
- Voltage Limits
- Tap Position Limits
- Runback
- Three independent Voltage Reduction Steps
- Sequential and Non-Sequential Operation
- VT Ratio Correction
- Self-Test Alarm Output Contacts
- User Programmable Alarm Contacts
- Tap Position Knowledge by "Keep Track" method
- Operations Counter
- Resettable Operations Counter
- Harmonic Analysis
- Tap Position Record
- Auto/Off/Manual Switch Status
- A or B Regulator Type Selection
- Alarm Contact Outputs (2)
- Control Voltage Input
- Motor Power Input
- Line Current Input
- Raise Output
- Lower Output
- 20 Character by 2 Row LCD Display
- M-2029A TapTalk® Communications Software
- M-2829 TapPlot™ Tap Analysis Software
- Front Panel LEDs for Out-of-Band **Raise**, Out-of-Band **Lower**, Reverse Power Flow **Rev Pwr** Detected, CPU **OK**, Line Drop Compensation **LDC** In Effect, Voltage Reduction **V/RED** in Effect and Auto Operation block **MANUAL** (**LOCAL** LED is NOT functional on BASE-T Versions).
- Includes BECO 2200 protocol on COM2 port
- Circulating Current Paralleling Method
- Front RS-232 Communications Port COM2
- Tap Position Knowledge by Current Loop Method
- External inhibit of Auto Tapchange (non-sequential)
- Circulating Current Input
- Voltage Reduction 1 & 2 Inputs (Binary) (3 Steps Total)
- Neutral Position Detect (Binary)
- Counter Input (Binary)
- Seal-in/Switch Status Input (Binary)
- Non-sequential/SCADA Block Input (Binary)
- Seal-in Output

## Base-T Optional Features

- Vacuum Fluorescent Display(rated -40 to +80 degrees Celsius.)
- **ΔVAR™** Paralleling Methods

## Base-T Accessories

- M-2025C Current Loop Interface Module-Current-To-Voltage analog converter for tap position sensors
- M-2026 AC-DC Control Power Backup Supply
- M-2027 Control Power Backup Supply - AC Only
- M-2948 Tap Position Sensor - measures a 0° to 288° rotation
- M-2949 Tap Position Sensor - measures a 0° to 320° rotation

## Base-RS Version Features

The Base-RS version of the M-2001C is designed primarily for regulators, but can also be applied to LTCs where SCADA communication is required. It provides one SCADA COMM port (COM1) as either an optional RS-485 or fiber optics port for communications.

- Adjustable Bandcenter
- Adjustable Bandwidth
- Line Drop Compensation, R and X Compensation
- Time Delay, Definite and Inverse
- InterTap Time Delay
- Selectable Outputs, Continuous or Pulsed
- Reverse Power Operation, for Single-Phase Regulator applications
- CT to VT Phasing Correction
- Real-Time Metering of measured and calculated parameters
- Demand Metering with selectable time interval
- Drag Hands Operation
- Adjustable Line Overcurrent Tapchange Inhibit
- Voltage Limits
- Tap Position Limits
- Runback
- Three independent Voltage Reduction Steps
- Sequential and Non-Sequential Operation
- VT Ratio Correction
- Tap Position Knowledge by "Keep Track" method
- Operations Counter
- Resettable Operations Counter
- Harmonic Analysis through TapTalk®
- Tap Position Record
- Auto/Off/Manual Switch Status
- A or B Regulator Type Selection
- Control Voltage Input
- Motor Power Input
- Line Current Input
- Raise Output
- Lower Output
- 20 Character by 2 Row LCD Display
- M-2029A TapTalk Communications Software
- M-2829 TapPlot™ Tap Analysis Software
- Adapter Panel Auto/Manual Switch Type Selection
- Front Panel LEDs for Out-of-Band **Raise**, Out-of-Band **Lower**, Reverse Power Flow **Rev Pwr** Detected, CPU **OK**, Line Drop Compensation **LDC** In Effect, Voltage Reduction **V/RED** in Effect, Auto Operation Block **MANUAL**, SCADA Control blocked **LOCAL** and Com1 **TX** and **RX**.
- Includes BECO 2200 protocol on COM2 port
- Front RS-232 Communications Port COM2
- Voltage Reduction 1 & 2 Inputs (Binary) (3 Steps Total)
- Non-Sequential/SCADA Block Input (Binary)
- Neutral Position Detect (Binary)
- Counter Input (Binary)
- Seal-in/Switch Status Input (Binary)
- Seal-in Output
- Communication Protocols include BECO 2200, BECO 2179, Cooper 2179, Cooper 2179A, GP-2179, GP DNP3.0, DNP3.0, AL PWR DNP 3.0, MODBUS and IEC-61850.

## Base-RS Optional Features

- Vacuum Fluorescent Display (rated -40 to +80 degrees Celsius.)
- COM1 (top) RS-485 or Fiber Optics

## Base-R Version Features

The Base-R version of the M-2001C is designed primarily for regulators, but can also be applied to LTCs where no SCADA communication is required. It uses one COMM port (COM2) for communications.

- Adjustable Bandcenter
- Adjustable Bandwidth
- Line Drop Compensation, R and X Compensation
- Time Delay, Definite and Inverse
- InterTap Time Delay
- Selectable Outputs, Continuous or Pulsed
- Reverse Power Operation, for Transformer LTC and Single-Phase Regulator applications
- CT to VT Phasing Correction
- Real-Time Metering of measured and calculated parameters
- Demand Metering with selectable time interval
- Drag Hands Operation
- Adjustable Line Overcurrent Tapchange Inhibit
- Voltage Limits
- Tap Position Limits
- Runback
- Three independent Voltage Reduction Steps
- Sequential Operation
- VT Ratio Correction
- Tap Position Knowledge by "Keep Track" method
- Operations Counter
- Resettable Operations Counter
- Harmonic Analysis
- Tap Position Record
- Auto/Off/Manual Switch Status
- A or B Regulator Type Selection
- Control Voltage Input
- Motor Power Input
- Line Current Input
- Raise Output
- Lower Output
- 20 Character by 2 Row LCD Display
- M-2029A TapTalk® Communications Software
- M-2829 TapPlot™ Tap Analysis Software
- Front Panel LEDs for Out-of-Band **Raise**, Out-of-Band **Lower**, Reverse Power Flow **Rev Pwr Detected**, CPU **OK**, Line Drop Compensation **LDC In Effect**, Voltage Reduction **V/RED in Effect** and Auto Operation block **MANUAL (LOCAL LED is NOT functional on BASE-R Versions)**.
- Includes BECO 2200 protocol on COM2 port
- Front RS-232 Communications Port COM2
- Voltage Reduction 1 & 2 Inputs (Binary) (3 Steps Total)
- Neutral Position Detect (Binary)
- Counter Input (Binary)
- Seal-in/Switch Status Input (Binary)
- Seal-in Output

## Base-R Optional Features

- Vacuum Fluorescent Display (rated -40 to +80 degrees Celsius.)

## Features

■ **NOTE:** Not all features are included in all versions.

**Bandcenter:** Adjustable from 100 V to 135 V in 0.1 V increments.

**Bandwidth:** Adjustable from 1 V to 10 V in 0.1 V increments.

**Line Drop Compensation:** R and X compensation. Adjustable from –24 V to +24 V in 1 V increments. Z compensation available with adjustment of voltage raise from 0 V to +24 V, in increments of 1 V.

**Time Delay:** Definite; adjustable from 1 second to 120 seconds, in 1 second increments. Inverse; adjustable from 1 second to 120 seconds, in 1 second increments.

**InterTap Time Delay:** Used to introduce time delay between tap operations when control is in sequential mode; adjustable from 0 to 60 seconds in 1.0 second increments. Counter input required.

**Selectable Outputs:** Continuous or pulsed. Normally, an output (raise or lower) signal is maintained when the voltage remains outside the band. A pulsed output length is programmable from 0.2 to 12 seconds, in increments of 0.1 second.

### Reverse Power Operation:

*Transformer LTC Application:* Can be set to ignore, block, regulate rev, or return to neutral operation with reverse power (when using positive tap position knowledge).

*Single-Phase Regulators:* If "keep track" tap position indication is applicable, unit may be set to "Return to Neutral" or "Regulate Reverse". The Regulate Reverse feature allows separate setpoints and regulation in the reverse direction without the installation of source-side VTs, otherwise it can be set to Ignore or Block.

**CT to VT Phasing Correction:** Adjustable from 0° to +330° in 30° increments.

**Real-Time Metering:** The following measured and calculated values are available in real-time:

- Local Voltage
- Load kVA, or MVA
- Load Center Voltage (Compensated Voltage)
- Load kW, or MW
- Line Current
- Load kVAr, or MVAR
- Power Factor
- Line Frequency

**Demand Metering:** Time interval selected as 15, 30, or 60 minutes.

### Drag Hands Operation:

The following "drag-hand" values are stored with date and time stamping and are averaged over 32 seconds:

- Minimum Local Voltage
- Maximum Local Voltage

The following "drag-hand" values are stored with date and time stamping and are calculated over the demand time interval (15, 30, or 60 minutes) as selected by the user:

- Maximum Primary Line Current
- Maximum Load kW, or MW
- Maximum Load kVAr, or MVAR
- Maximum Load kVA, or MVA (and Power Factor at time of Maximum Load kVA, or MVA)

**Line Overcurrent Tapchange Inhibit:** Adjustable from 200 mA to 640 mA of line current for 200 mA CT or 1.0 A to 3.2 A for 1 A CT display and 5.0 A to 16.0 A for 5 A CT display. External auxiliary CT required for 1.0 A and 5 A CT inputs.

**Voltage Limits, Tap Position Limits, and Runback:** Overvoltage and Undervoltage limits are independently adjustable from 95 V to 135 V in 0.1 V increments. Upper and lower tap position limits may be set by user, with tap position knowledge active. An adjustable deadband (above the overvoltage limit) of 1 V to 4 V is available, which is used to set the runback limit.

**Voltage Reduction:** Three independent steps, each adjustable from 0% to 10% in 0.1% increments of the bandcenter setpoint.

**Inhibit of Auto Tapchange:** Blocks automatic tapchanger operation in response to external contact closure or software setting.

**Sequential or Non-Sequential Operation:** Non-sequential operation resets the time delay upon momentary external contact closure at the non-sequential input.

**Paralleling Methods:**

*Circulating Current:* The circulating current method is standard, and may be implemented using separate balancing equipment such as the Beckwith Electric M-0115A Parallel Balancing Module. Consult with factory for use with existing external master-follower circuitry.

**ΔVAR™:** When specified, the ΔVAR1 method may be implemented by using separate balancing equipment such as the M-0115A Balancing Module. The ΔVAR2 method does not require the use of the M-0115A Balancing Module and is only applicable when paralleling two transformers.

For all methods of paralleling except ΔVAR2, overcurrent protection, such as that provided by the M-0127A Overcurrent Relay, is recommended.

**VT Ratio Correction:** VT correction from –15 V to +15 V in 0.1 V increments.

**Self-Test Alarm Output Contacts:** Alerts operator to loss of power or malfunction of control. When the control is configured for SCAMP Pushbutton Auto/Manual Switch Type, this output is not available.

**User-Programmable Alarm Contacts:** Alerts operator to one or more of the following system conditions: Communications Block Invoked, Block Raise Voltage Limit Exceeded, Block Lower Voltage Limit Exceeded, Voltage Reduction (any step) Invoked, Reverse Power Flow Condition Detected, Line Current Limit Exceeded, Tap Block Raise in Effect, and Tap Block Lower in Effect.

**Tap Position Knowledge**

*Transformer LTC:* The optional M-2025B Current Loop Interface Module receives a signal from a position transducer and outputs to the M-2001C through a bottom port.

*Single-Phase Regulators:* In most applications, tap position information can be maintained by means of an internal "keep track" logic.

**Operations Counter:** A software counter increments by one count per either an open/close/open contact operation (X1) or an open/close or close/open contact operation (X2), and is preset by the user. A count window mode registers any activity as a valid input within the count window time setting.

**Resettable Operations Counter:** A second software counter, similar to the operations counter, which may be reset by the user.

**Harmonic Analysis:** Provides the total harmonic distortion and the harmonic content of the load voltage and current up to the 31st harmonic (using TapTalk with BECO 2200 protocol).

**Tap Position Record:** Provides a record of the number of times each tap position has been passed through (using TapTalk with BECO 2200 protocol). The tap position record can be reset by the user.

**AUTO/MANUAL Switch Status:** Provides the user with the Auto/Manual switch position status through the Comm ports. When the M-2001C is configured for a switch status input, the switch status is read using the seal-in input on the control. When configured for Seal-in INPUT, the switch status is read using the counter INPUT.

**A or B Regulator Type:** Allows the user to select the type of regulator being used to provide a more accurate source voltage calculation.

**Inputs**

**Control Voltage Input:** Nominal 120 V ac, 60 Hz (50 Hz optional); operates properly from 90 V ac to 140 V ac. If set at 60 Hz, the operating system frequency is from 55 to 65 Hz; if set at 50 Hz, the operating system frequency is from 45 to 55 Hz. The burden imposed on the input is 8 VA or less. The unit should be powered from a voltage transformer connected at the controlled voltage bus. The unit will withstand twice the voltage input for one second and four times the voltage input for one cycle.

**Motor Power Input:** Nominal 120 V ac to 240 V ac, at up to 6 A as required by the load, with no wiring changes required.



## M-2001C Digital Tapchanger Control

**Line Current Input:** Line drop compensation is provided by a current transformer input with a 0.2 A full scale rating. A Beckwith Electric model M-0121 (5 A to 0.2 A) or M-0169A (5 A or 8.66 A to 0.2 A) Auxiliary Current Transformer is available when required. The burden imposed on the current source is 0.03 VA or less at 200 mA. The input will withstand 400 mA for two hours and 4 A for 1 second.

**Circulating Current Input:** Parallel operation of regulators or transformers is accommodated by a current transformer input with a 0.2 A full scale rating. The burden imposed on the current source is 0.03 VA or less at 200 mA. The input will withstand 400 mA for two hours and 4 A for 1 second.

**Control Power Backup Input** (Six pin Molex connector on the left side bottom of control): The optional Control Power Backup Input feature sustains operation of the control in the event of a loss of AC input power to the control. Raise and Lower commands are possible if the control's motor power remains energized. When this feature is enabled the Tap Position Knowledge by Current Loop feature is unavailable. See M-2026/M2027 Companion Control Power Backup Supplies (page 14).

## Binary Inputs

**Voltage Reduction 1 & 2 Inputs:** These inputs provide three levels of programmable voltage reduction which can be manually invoked.

**Neutral Position Detect:** The Neutral Position Detect Input detects the neutral tap position, which assists the "keep track" tap position function. This Neutral Position Detect Input also facilitates disabling the paralleling mode Delta Var2.

**Counter Input/Switch Status Input:** When Input Selection 1 configuration is set to Switch Status, the Counter Input detects tap position changes and updates two counters, one pre-settable and one re-settable. When Input Selection 1 configuration is set to Seal-In, the counter input is used as the Switch Status Input and the Seal-In input will cause the counter to increment.

**Seal-in/Switch Status Input:** When the Input Selection 1 configuration is set to "seal-in input", this input provides for detection of the seal-in state to operate the seal-in output and will also increment the counters. When "Input Selection 1" is set to Switch Status Input, this input provides the means to read the Auto/Manual switch position status using SCADA.

**Non-Sequential/SCADA Cutout Input:** When the Input Selection 2 configuration is set to "Nonseq Input", this input provides the means to perform non-sequential operations. When Input Selection 2 is set to "SCADA Cutout Input", this input provides a means to block all write operations to the control from SCADA.

## Outputs

**Raise Output:** Capable of switching 6 A at 120 Vac to 240 V ac motor power.

**Lower Output:** Capable of switching 6 A at 120 Vac to 240 V ac motor power.

**Seal-In Output:** Connects to the B-0553 motor seal-in printed circuit board subassembly.

**Deadman Alarm Output:** Capable of switching 6 A at 120 V ac or 100 mA at 120 V dc.

**Programmable Alarm Output:** Capable of switching 3 A at 120 V ac or 100 mA at 120 V dc.

## Front Panel Controls

Menu-driven access to all functions by way of four pushbuttons and a two-line alphanumeric display. There are two programmable passwords available to provide various levels of access to the control functions.

The M-2001C offers a 2-line by 20 character LCD display for enhanced viewing in direct sunlight. It also offers a low-level LED backlight for reading in darker environments. An optional 2-line by 20 character Vacuum Fluorescent Display (VFD) is available for industrial temperature range operations (–40° C to +80° C).

## LED Indicators

Front panel LED indicators show the following control conditions: Out-of-Band **RAISE**, Out-of-Band **LOWER**, Reverse Power Flow **REV PWR** detected, CPU **OK.**, Line Drop Compensation **LDC IN EFFECT**, Voltage Reduction **V/RED IN EFFECT**, Communications or Front Panel Auto Operation Block **MANUAL**, **SCADA** control blocked **LOCAL** and **COM1 TX and RX**.

## Output Contacts

**Alarm Contact Outputs (2):** One normally open programmable contact capable of switching 3A at 120 V ac and one normally closed self-test alarm contact; capable of switching 6 A at 120 V ac.

## Voltage Measurement Accuracy

Control accuracy is  $\pm 0.3\%$  when tested in accordance with the ANSI/IEEE C57.15.9-1999 standard over a temperature range of  $-30^{\circ}\text{C}$  to  $+65^{\circ}\text{C}$ . The control accuracy is  $\pm 0.5\%$  when tested over the full operational temperature range of  $-40^{\circ}\text{C}$  to  $+85^{\circ}\text{C}$ .

## Communications

The communication ports provide access to all features, including metering, software updates, and programming of all functions. This is accomplished using a modem or direct serial connection from any IBM PC-compatible personal computer running the M-2029A TapTalk® Communications Software package or SCADA communications software. COM1 (top) is available with RS-232, RS-485 or Fiber Optics. COM3 is an optional RJ45 Ethernet Port. COM2 is an RS-232 front port for local communications with TapTalk BECO 2200 and for software updates.

**Protocols:** The following standard protocols are included in COM1/COM3: BECO 2200, BECO 2179, Cooper 2179, Cooper 2179A, GP 2179, GP DNP 3.0, AL PWR DNP 3.0, DNP3.0, MODBUS, and IEC 61850 (when used with the optional ethernet port). COM2 uses BECO 2200 for local communications.

**Communications Via Direct Connection:** TapTalk® supports direct communication with a Beckwith Electric M-2001C Digital Tapchanger Control using a serial “null modem” cable with a 9-pin connector (DE9P) for the control, and the applicable connector (usually DE9S or DB25S) for the PC, or Fiber Optic communication using ST standard or two-wire RS-485.

**Optional:** An optional ethernet 10 Mbps port (COM 3) is available (Comprehensive Version only) through an RJ-45 jack on the top of the control. This port supports DNP over TCP/IP, BECO 2200 over TCP/IP, MODBUS over TCP/IP protocols and IEC61850.

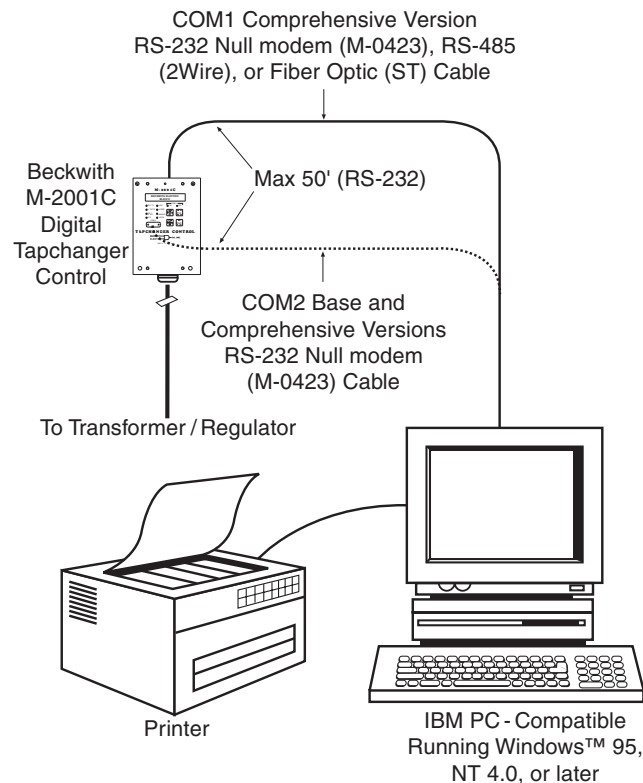

Figure 1 Direct Connection

## M-2001C Digital Tapchanger Control

**Communications Via Modem:** TapTalk® supports remote (modem) communications with a Beckwith Electric M-2001C Digital Tapchanger Control (COM1 or COM2, COM1 shown). A Hayes-compatible modem and proper cabling is required.

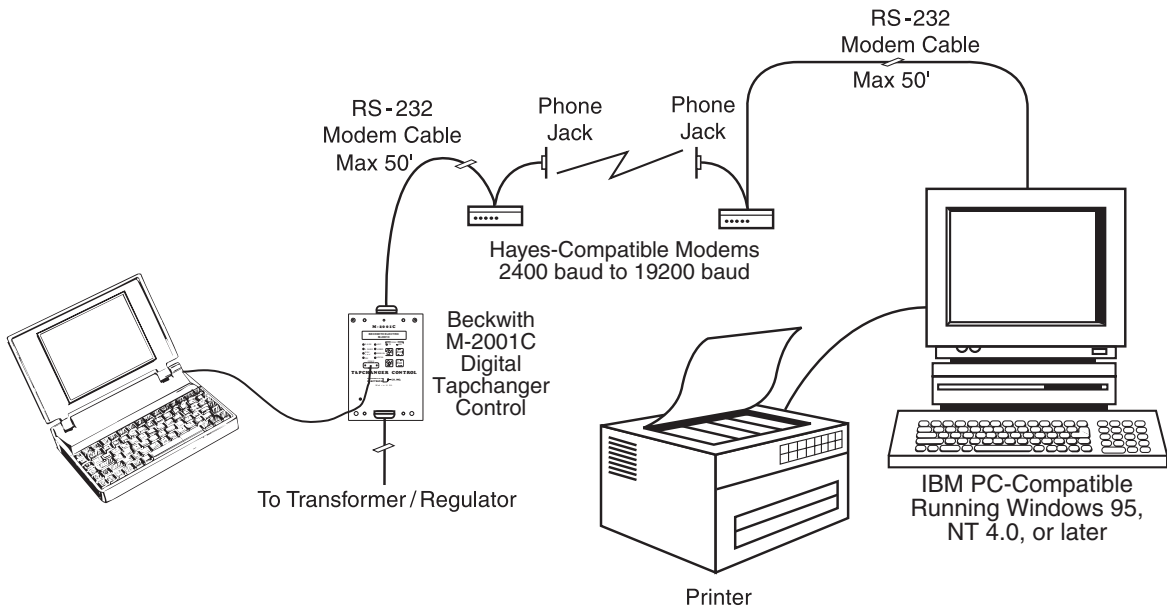

Figure 2 Modem Connection

**Communications Using Networking:** The addressing capability of TapTalk allows networking of multiple Beckwith Electric digital tapchanger controls (COM1 or COM2, COM1 shown). Each tapchanger control can be assigned an address ranging from 1 to 200. Selected commands may be broadcast to all controls on the network. Figures 3, 4, and 5 illustrate typical network configurations.

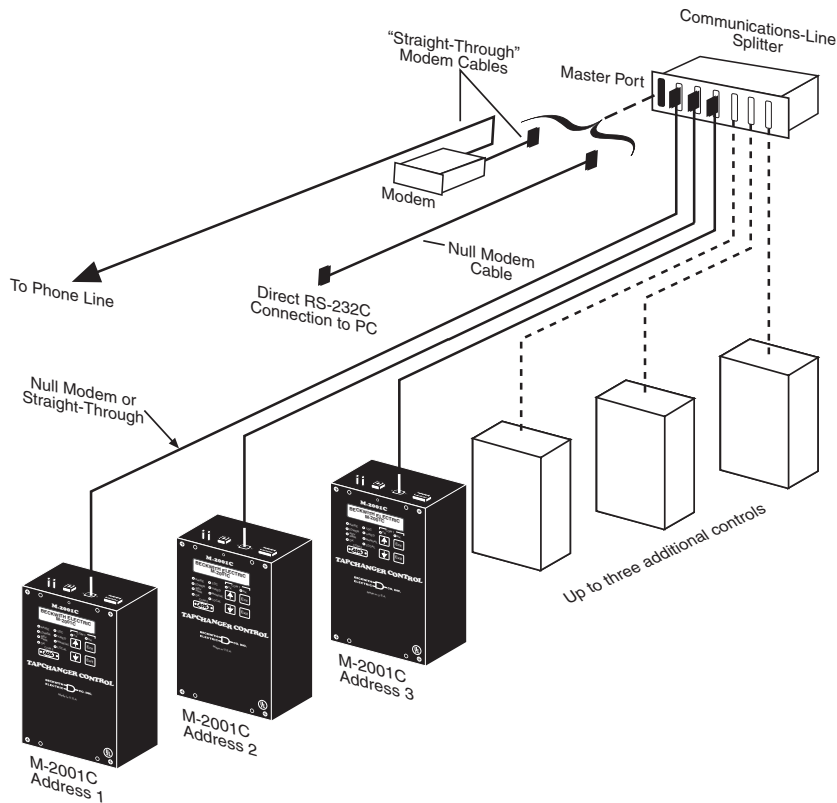

Figure 3 Network Connection

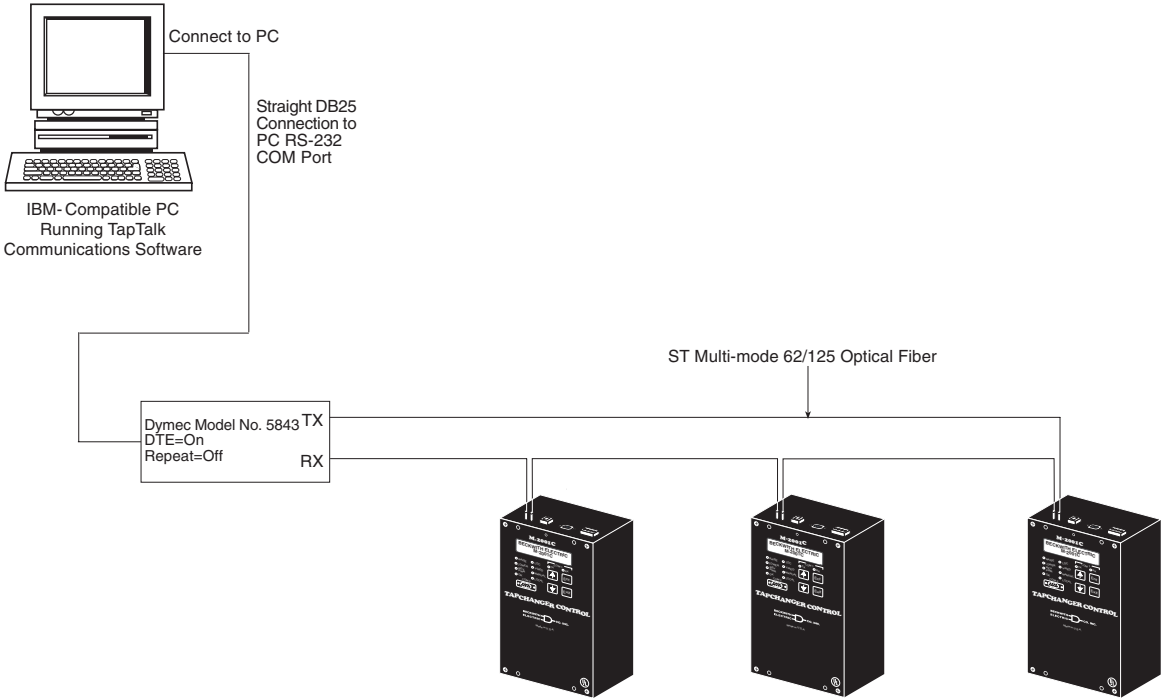

Figure 4 Fiber Optic Connection Loop

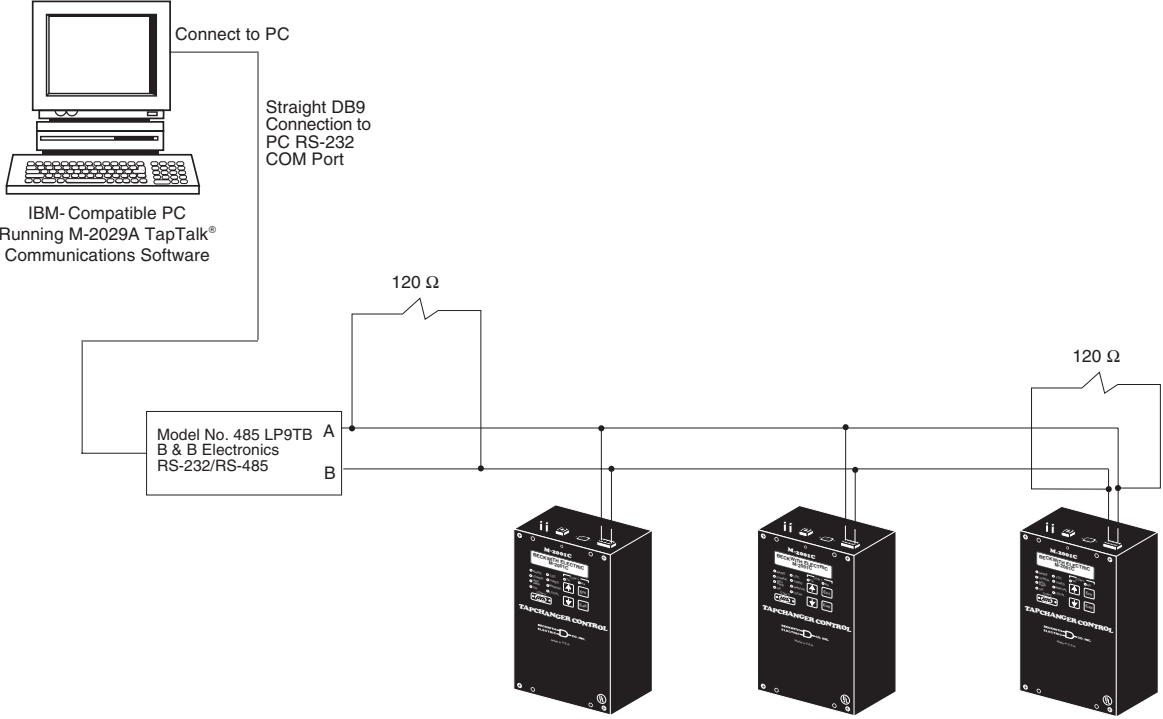

Figure 5 RS-485 Network Connection

## M-2001C Digital Tapchanger Control

**Application:** Using a PC, the operator has real-time, remote access to all functions of the M-2001C Digital Tapchanger Control. The control can act as the monitoring point for all voltage, current, and related power quantities, thereby simplifying operation while avoiding transducers and multiple Remote Terminal Unit (RTU) analog inputs. The protocols implement half-duplex, two-way communications. This allows all functions, which would otherwise require the presence of an operator at the control, to be performed remotely. Communication capabilities include:

- Interrogation and modification of setpoints
- Broadcast of commands, such as tap change inhibit and voltage reduction (up to three steps) to networked controls
- Recognition of alarm conditions, such as voltage extremes and excessive load
- Selective control of raise and lower tap change operations
- Re-configuration of the control, such as a change to the demand integration time period or a selection of different alarm parameters

**Unit Identifier:** A 2-row by 15-character alphanumeric sequence, set by the user, can be used for unit identification.

## Environmental

**Temperature:** Control operates from  $-40^{\circ}\text{C}$  to  $+85^{\circ}\text{C}$  with either the LCD or Vacuum Fluorescent display.

■ **NOTE:** The LCD display's functional temperature range is  $-20^{\circ}\text{C}$  to  $+70^{\circ}\text{C}$ . The optional Vacuum Fluorescent display's functional temperature range is  $-40^{\circ}\text{C}$  to  $+80^{\circ}\text{C}$ .

IEC 60068-2-1 Cold,  $-40^{\circ}\text{C}$  for 96 hours

IEC 60068-2-2 Dry Heat,  $+80^{\circ}\text{C}$  for 96 hours

IEC 60068-2-3 Damp Heat,  $+40^{\circ}\text{C}$  @ 95% RH for 96 hours

**Fungus Resistance:** a conformal coating is available as an option on the printed circuit board to inhibit fungus growth.

## Transient Protection

### *High Voltage*

All input and output terminals will withstand 1500 V ac rms to chassis or instrument ground for one minute with a leakage current not to exceed 25 mA, for all terminals to ground. Input and output circuits are electrically isolated from each other, from other circuits and from ground.

■ **NOTE:** RS-232 and RS-485 communications ports are excluded.

### *Surge Withstand Capability*

IEEE C37.90.1-2002    2,500 Vpk-pk Oscillatory  
                                  4,000 Vpk Fast Transient Burst

IEEE C37.90.1-1989    2,500 Vpk-pk Oscillatory  
                                  5,000 Vpk Fast Transient

■ **NOTE:** Disturbance is applied to digital data circuits (RS-232, RS-485, RJ45 Ethernet) port through capacitive coupling clamp.

### *Radiated Electromagnetic Withstand Capability*

All units are protected against electromagnetic radiated interference from portable communications transceivers.

### *Electrostatic Discharge Test*

EN 60255-22-2-1997 (EN61000-4-2)

Class 4                (8 Kv) – Point Contact Discharge  
                                  (15 Kv) – Air Discharge

### **Fast Transient Disturbance Test**

EN 60255-22-4-2002 (EN61000-4-4)

Class A (4 Kv, 2.5 kHz)

■ **NOTE:** Disturbance is applied to digital data circuits (RS-232, RS-485, RJ45 Ethernet) ports through capacitive coupling clamp.

### **Industrial Certifications**

cULus-Listed per 508 – Industrial Control Equipment

– Industrial Control Equipment Certified for Canada CAN/CSA C22.2 No. 14-M91

cULus-Listed Component per 508A Table SA1.1 Industrial Control Panels

### **Physical**

(M-2001C Comprehensive, BASE-T, BASE-RS, BASE-R)

**Size:** 5 13/16" wide x 8 1/2" high x 3" deep (10.81 cm x 21.6 cm x 7.62 cm)

**Mounting:** Unit mounts directly to adapter or conversion front panels sized to replace popular industry tapchanger controls.

**Approximate Weight:** 3 lbs, 11 oz (1.67 kg)

**Approximate Shipping Weight:** 6 lbs, 11 oz (3.03 kg)

### **Patent & Warranty**

The M-2001C Tapchanger Control is covered by U.S. Patents 5,315,527 and 5,581,173.

The M-2001C Tapchanger Control, M-2026 AC-DC Control Power Backup Supply and M-2027 Control Power Backup Supply-AC Only, M-2948 and M-2949 Tap Position Sensors, and M-2025B(C) Current Loop Interface Modules are covered by a five-year warranty from date of shipment.

*Specification subject to change without notice.*

## M-2025B and M-2025C Current Loop Interface Modules, M-2948 and M-2949 Tap Position Sensors

The M-2025B(C) Current Loop Interface Modules are a current-to-voltage analog converters that can accept inputs from:

- Beckwith Electric Tap Position Sensors
  - Model M-2948 (9° per tap)
  - Model M-2949 (10° per tap)
  - Future models as required
  
- Incon Tap Position Monitor connected to an Incon 1250 Series Rotary Position Sensor

Both types of devices provide a 4-20 mA dc current loop output. The current loop develops a voltage across a properly sized resistor on the input to the M-2025B(C). The resultant voltage signal is conditioned in the M-2025B(C) and routed to the M-2001 series Tapchanger Control where the voltage is converted to a corresponding tap position number.

The tap position sensors are rotary shaft encoders with built-in microprocessors that provide stepped output signals in 9 or 10 degree increments. They have rotations of 288 and 320 degrees respectively for 32 taps and one neutral position. The electrical output of these sensors is a 4-20 mA current loop that converts easily to a voltage signal at the input of the M-2025B(C) with the addition of a proper value shunt resistor. For a 4-20 MA Current Loop, 150 ohms is required on the input of the M-2025B(C).

### Configurations

Most LTC tapchangers have an output shaft on the tapchanger mechanism whose angular position is a mechanical analog of the tapchanger tap position. In many cases, the total range of tap positions is represented by less than one complete rotation of this position output shaft. The typical values of shaft movement on 32 tap mechanisms are 9° or 10° of mechanical rotation per tap position.

Other angular rotation values are likely to be encountered. Contact Beckwith Electric for information on sensor availability for specific requirements.

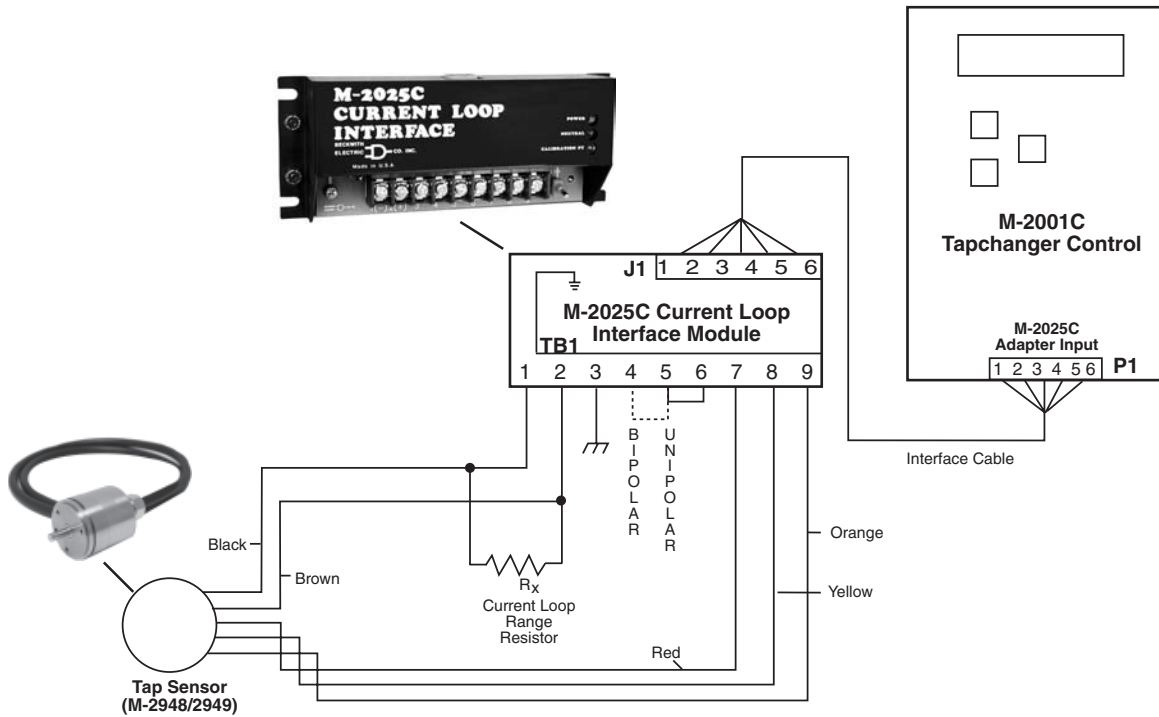

Figure 6 Typical M-2025B(C) External Tap Position Interface with M-2948/M-2949 Tap Position Sensors

### M-2026/M-2027 Control Power Backup Supplies

If the Optional Control Power Backup Input is purchased, the following accessories are available:

#### M-2026 AC-DC Control Power Backup Supply

The M-2026 Control Power Backup Supply will accept either an AC or DC (105 to 140 V) input, and output a regulated +12 V dc ( $\pm 0.5$  V) output voltage. The unit incorporates a fused input, surge protection, and reverse polarity protection. The M-2026 is capable of up to a 1.5 Ampere output.

#### M-2027 Control Power Backup Supply-AC Only

The M-2027 will accept an AC (105 to 140 VAC, 50/60 Hz) input and output +12 V dc (Nominal). The M-2027 is capable of loads up to 1.0 Ampere. The unit incorporates a fused input and surge protection.

The M-2026 and M-2027 units are housed in a non-weathertight enclosure and equipped with screw terminal blocks for input and output connections.

■ **NOTE:** If the Optional Control Power Backup input is purchased, then Tap Information is limited to "keep track" only.

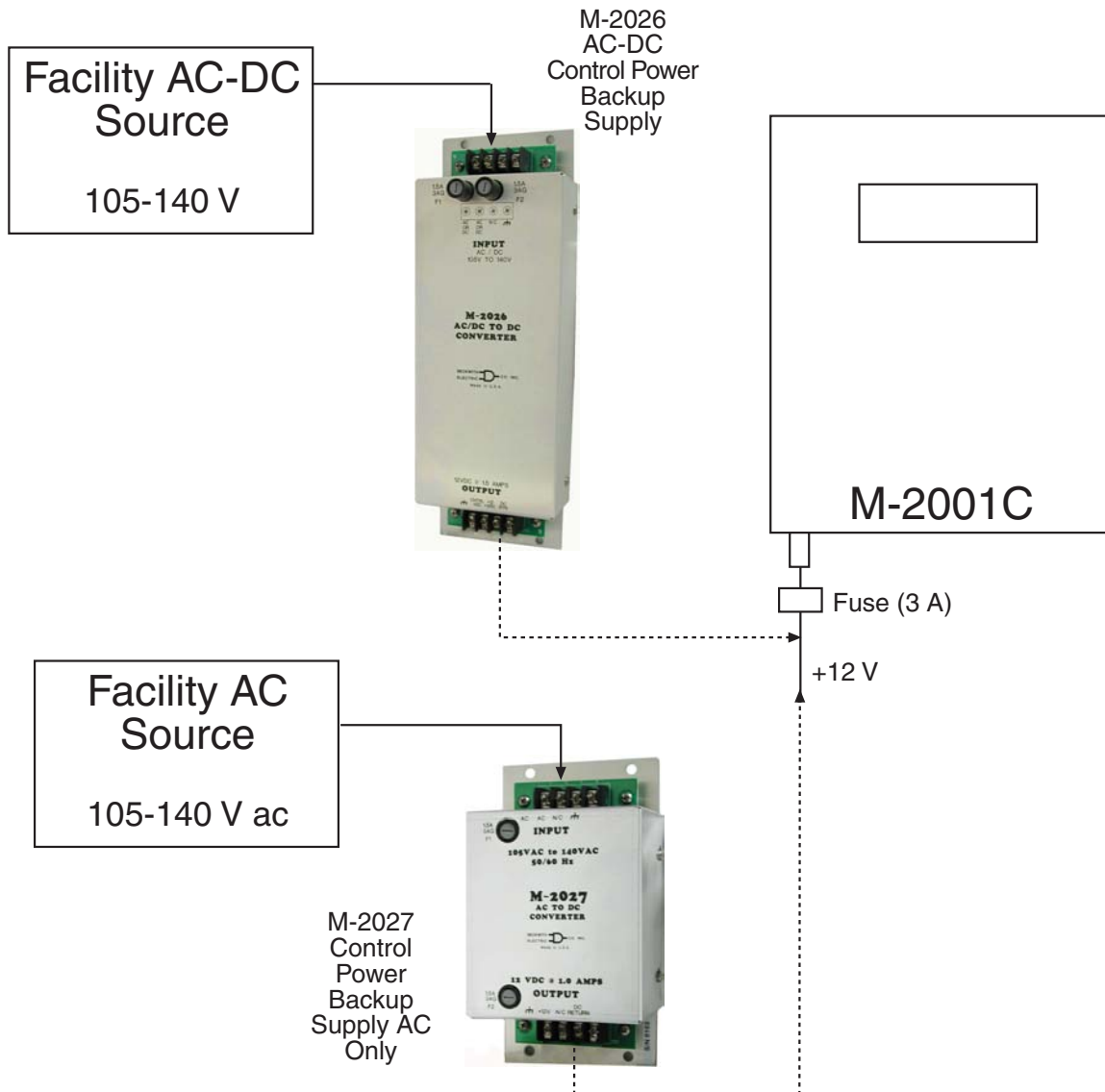



# M-2001C Style Selection Chart

## M-2001C- 6 N L A A

<b>Frequency</b> 6 = 60 Hz operation 5 = 50Hz operation				
<b>Control Type</b> N = Base R R = Base RS w / RS-485 F = Base RS w / Fiber Optic T = Base T S = Comprehensive E = Comp. w / Ethernet U = Ethernet w / IEC 61850				
<b>Display type</b> L = LCD V = Vacuum Fluorescent				
<b>Additional options</b> A = No additional option B = Δ-Var Paralleling C = Control Power Backup input D = Both B & C				
<b>Custom Mods</b> A = No Mod				

Option Availability:	VFD	D-VAR	Ethernet	DC pwr
M-2001C - Comp	Yes	Yes	Yes	Yes
M-2001C - Base-T	Yes	Yes	N/A	N/A
M-2001C - Base-R	Yes	N/A	N/A	N/A
M-2001C - Base-RS	Yes	N/A	N/A	N/A

### Example Style Numbers:

**M-2001C-6SV Comprehensive LTC Control (60Hz) with Vacuum Fluorescent Display (VFD). Inputs/Outputs: Non-sequential, Paralleling, Alarms, Tap Info (INCON), Voltage reduction, LDC. Communication: RS232, RS485 & Fiber optic ports, 9 protocols including DNP 3.0 & Modbus**

**M-2001C-5TLBA Base-T LTC Control (50Hz) With LCD. Inputs/Outputs: Non-sequential, Paralleling, Alarms, Tap Info (INCON), Voltage reduction, LDC. . Communication: RS232, BECO-2200 protocol only. Options: Delta Var paralleling**

**M-2001C-6NL Base-R Regulator Control (60Hz) With LCD. Inputs: Voltage reduction, LDC. Communication: RS232, BECO-2200 protocol only**



## BECKWITH ELECTRIC CO., INC.

6190 - 118th Avenue North • Largo, Florida 33773-3724 U.S.A.

PHONE (727)544-2326 • FAX (727)546-0121

E-MAIL [marketing@beckwithelectric.com](mailto:marketing@beckwithelectric.com)

WEB PAGE [www.beckwithelectric.com](http://www.beckwithelectric.com)

# WARNING

**DANGEROUS VOLTAGES, capable of causing death or serious injury, are present on the external terminals and inside the equipment. Use extreme caution and follow all safety rules when handling, testing or adjusting the equipment. However, these internal voltage levels are no greater than the voltages applied to the external terminals.**

## **DANGER! HIGH VOLTAGE**



- This sign warns that the area is connected to a dangerous high voltage, and you must never touch it.

## **PERSONNEL SAFETY PRECAUTIONS**

*The following general rules and other specific warnings throughout the manual must be followed during application, test or repair of this equipment. Failure to do so will violate standards for safety in the design, manufacture, and intended use of the product. Qualified personnel should be the only ones who operate and maintain this equipment. Beckwith Electric Co., Inc. assumes no liability for the customer's failure to comply with these requirements.*



- This sign means that you should refer to the corresponding section of the operation manual for important information before proceeding.



### **Always Ground the Equipment**

To avoid possible shock hazard, the chassis must be connected to an electrical ground. When servicing equipment in a test area, the Protective Earth Terminal must be attached to a separate ground securely by use of a tool, since it is not grounded by external connectors.

### **Do NOT operate in an explosive environment**

Do not operate this equipment in the presence of flammable or explosive gases or fumes. To do so would risk a possible fire or explosion.

### **Keep away from live circuits**

Operating personnel must not remove the cover or expose the printed circuit board while power is applied. In no case may components be replaced with power applied. In some instances, dangerous voltages may exist even when power is disconnected. To avoid electrical shock, always disconnect power and discharge circuits before working on the unit.

### **Exercise care during installation, operation, & maintenance procedures**

The equipment described in this manual contains voltages high enough to cause serious injury or death. Only qualified personnel should install, operate, test, and maintain this equipment. Be sure that all personnel safety procedures are carefully followed. Exercise due care when operating or servicing alone.

### **Do not modify equipment**

Do not perform any unauthorized modifications on this instrument. Return of the unit to a Beckwith Electric repair facility is preferred. If authorized modifications are to be attempted, be sure to follow replacement procedures carefully to assure that safety features are maintained.

## **PRODUCT CAUTIONS**

*Before attempting any test, calibration, or maintenance procedure, personnel must be completely familiar with the particular circuitry of this unit, and have an adequate understanding of field effect devices. If a component is found to be defective, always follow replacement procedures carefully to that assure safety features are maintained. Always replace components with those of equal or better quality as shown in the Parts List of the Instruction Book.*

### **Avoid static charge**

This unit contains MOS circuitry, which can be damaged by improper test or rework procedures. Care should be taken to avoid static charge on work surfaces and service personnel.

### **Use caution when measuring resistances**

Any attempt to measure resistances between points on the printed circuit board, unless otherwise noted in the Instruction Book, is likely to cause damage to the unit.

# M-2001C “SimpleStart” Initial Setup Instructions

## Communicating with the M-2001C

Determine the method of communicating with the M-2001C:

Utilizing the front panel four pushbutton Human Machine Interface (HMI).

By connecting to the front panel RS-232 communications port with a laptop PC utilizing TapTalk for Windows Communications Software.

By connecting to the SCADA communications ports on the top of the unit.

## Apply Power to the M-2001C

If the control is attached to an adapter panel, control power can be applied to the front “**External Power**” input or to the proper panel control input pins.

If the control is not attached to an adapter panel, or the “blue plug” is removed, the control may be energized utilizing a “**Blue Plug**” adapter cord (part number B-0849 available from Beckwith Electric) and a 120 V ac wall outlet.

## M-2001C Setup Procedure using the Front Panel HMI

1. Press the **↑**, **↓** or **Ent** pushbutton, the screen will display **LOCAL VOLTAGE**.
2. Confirm input voltage.
3. Press and hold the **↑** pushbutton until **TIME OF DAY** is displayed, then press **Ent**, a flashing “**C**” will be displayed indicating that changes may be made.
4. Set the first digit of the time (indicated by an underline of the digit) with the **↑** or **↓** pushbutton, then press **Ent** to shift to the next digit. Repeat for each time digit.
5. When all time digits have been set, then press **↓** once, **DATE** will be displayed.
6. Press **Ent** to set the first digit of the date (indicated by an underline of the digit) with the **↑** or **↓** pushbutton, then press **Ent** to shift to the next digit. Repeat for each date digit.
7. When all date digits have been set, then press **↓** once, **VAR HRS R 1PH E** will be displayed.
8. Each demand quantity will display an “**E**” on the right side of the screen. Press **Ent** to reset the demand value to zero.
9. Press **↓** to display the next demand quantity, then press **Ent**.
10. Repeat Step 9 for each demand quantity, the last demand quantity is **OPER CNTR RSET**.
11. Press **Exit**, the screen will extinguish.
12. Review the default configuration settings in the M-2001C Instruction Book, Appendix A or B, and determine if any of the settings need to be changed for this application.
13. If no configuration settings need to be changed, then go to Step 15.

## M-2001C “SimpleStart” Initial Setup Instructions Cont’d

14. If configuration settings need to be changed, then proceed as follows:

- a) Press the **↑**, **↓** or **Ent** pushbutton, the screen will display **LOCAL VOLTAGE**.
- b) Confirm input voltage.
- c) Press **↓** once, **TO CONFIGURE COMMUNICATION** will be displayed.
- d) Press **Ent**, **LEVEL 2 PASSWORD** will be displayed.

■ **NOTE:** The default Level 2 Password is 2222 on new controls.

- e) Set the first digit of the Level 2 Password (indicated by an underline of the first digit) with the **↑** or **↓** pushbutton, then press **Ent** to shift to the next digit. Repeat for each digit.

When the last digit has been entered, the control will briefly display **LEVEL 2 ACCESS GRANTED!**. The control will then display **COMM PASSWORD**.

- f) Press the **↑** or **↓** pushbutton as necessary to advance to the desired configuration parameter.
- g) Press **Ent**, a flashing “**C**” will be displayed indicating that changes may be made.
- h) Press the **↑** or **↓** as necessary to toggle between the available settings, then press **Ent** to save the setting.
- i) When the required changes have been completed, press **EXIT**, the screen will extinguish.

15. Review the default setpoints in the M-2001C Instruction Book, Appendix A or B, and determine if any of the settings need to be changed for this application.

16. If no setpoints need to be changed, then go to the Data Logging section.

17. Press the **↑**, **↓** or **Ent** pushbutton, the screen will display **LOCAL VOLTAGE**.

18. Confirm input voltage.

19. Press **↓** twice, **BANDCENTER F** will be displayed. This screen marks the beginning of the setpoints.

20. Press the **↑** or **↓** pushbutton as necessary to advance to the desired setpoint, then press **Ent**.

- a) If a flashing “**C**” is displayed on the right side of the screen, then go to Step 21.

■ **NOTE:** The default Level 1 Password is 0000 (password disabled) on new controls.

- b) If **LEVEL 1 PASSWORD** is displayed (indicating a user defined password has been entered), then set the first digit of the Level 1 Password (indicated by an underline of the digit) with the **↑** or **↓** pushbutton, then press **Ent** to shift to the next digit. Repeat for each digit.

When the last digit has been entered and the proper password has been entered, then a flashing “**C**” will be displayed indicating that changes may be made. Go to Step 21.

21. Press the **↑** or **↓** as necessary to toggle between the available settings, then press **Ent** to save the setting.

22. For additional setpoint changes press the **↑** or **↓** pushbutton as necessary to advance to the desired setpoint, then repeat Step 21 for each setpoint to be changed.

23. When the required setpoint changes have been completed press **EXIT**, the screen will extinguish.

# M-2001C “SimpleStart” Initial Setup Instructions Cont’d

## **TapTalk Communications Software for Windows**

PC hardware requirements, communications utilizing a modem, communicating with multiple units and an overview of TapTalk software operation can be found in the M-2001C Instruction Book, Chapter 9.

TapTalk Communications Software is provided on a CD-ROM with each unit. It is also available at <http://www.beckwithelectric.com/tapchangers/m2029/m2029a.htm> .

## **Install M-2029A TapTalk Communications Software (PC)**

1. Insert the TapTalk software into your CD-ROM drive or download the M-2029A software.
2. Select **Run** from the **Start Menu**.
3. From the **Run** dialog box, initiate software installation by typing **D:\Setup.exe** (or other drive designator:\Setup.exe, depending on the letter designation for the CD-ROM drive or location of the downloaded file).

The Installation Wizard will prompt the user through the installation process. After installation, the TapTalk program icon (located in the Becoware folder) can be placed on the desktop.

## **M-2001C Setup Procedure using TapTalk**

1. Connect a Null Modem Cable from the active PC COM Port to COMM 2 on the front of control.
2. Select the TapTalk program-item icon from the Becoware group in the Program Manager, or select TapTalk from the program list using the Start Menu.

The TapTalk toolbar is displayed along with the Access dialog screen.

3. The Access dialog screen contains the following new control default values:

    Password – no changes needed

    Comm Address – 1

    Control Comm Protocol – BECO2200

    PC Communication Device – Serial Comm Port

    PC COM Port – COM1

    PC Baud Rate – 9600

4. On the Access dialog screen verify the following:

    PC COM Port is set to the active PC COM Port that the Null Modem Cable is connected to.

    Active PC COM Port baud rate is set to 9600.

■ **NOTE:** The local display screen must be extinguished (press **EXIT**) in order to access the control through the communication ports.

5. From the Access dialog screen select **OPEN** to open communications. If the correct COM Port parameters have been entered TapTalk will respond with:

    “Communication has been opened successfully”.

6. From the Access screen, select **OK** to close the Access screen.

7. From the drop down menu, select **Utilities/Set Control Date/Time**. The Set Control Date/Time dialog screen will be displayed.

## M-2001C “SimpleStart” Initial Setup Instructions Cont’d

8. The Set Control Date/Time dialog screen **Set Control Time** section, default setting for Current Address or Broadcast is set to Current Address. If multiple controls are being set, then select Broadcast.
9. If the control is to be set to PC Time, then select **Set Control Time to PC Time**. TapTalk will respond with a confirmation screen that states:

“Control’s time has been successfully set to PC’s time.  
Do you want to reset the following points:  
Demand Metering, Energy Metering, Drag Hands and Resettable Op Count?  
Click Yes to reset the values,  
Click No to continue without resetting.”

Select **Yes**, Tap Talk will respond with the confirmation screen that states:  
“Demand Metering, Energy Metering, Drag Hands and Resettable Op Count have been reset.”
10. If the control is to be set to a time that is manually input, then input the desired time and select **Set**. TapTalk will respond with a confirmation screen that states:

“Control’s time has been successfully set to PC’s time.  
Do you want to reset the following points:  
Demand Metering, Energy Metering, Drag Hands and Resettable Op Count?  
Click Yes to reset the values,  
Click No to continue without resetting.”

Select **Yes**, TapTalk will respond with the confirmation screen:  
“Demand Metering, Energy Metering, Drag Hands and Resettable Op Count have been reset.”
11. From the Set Control Date/Time screen select **Exit**.
12. From the drop down menu, select **Control Setup/Configuration**. The Configuration dialog screen will be displayed.
13. Review the default configuration settings and determine if any of the settings need to be changed for this application.
14. If no configuration settings need to be changed, then go to Step 16.
15. If configuration settings need to be changed, then proceed as follows:
  - a) From the Configuration Dialog screen, select and edit the desired configuration setting(s).
  - b) Select **Write To Control**, TapTalk will respond with a confirmation screen that states:  
“Configuration settings have been successfully written to the control.”
  - c) Select **Exit**.
16. From the drop down menu, select **Control Setup/Setpoints**. The Setpoints dialog screen will be displayed.
17. Review the default setpoints and determine if any of the setpoints need to be changed for this application.
18. If no setpoints need to be changed, then go to the Data Logging section.
19. If setpoints need to be changed, then proceed as follows:
  - a) From the Setpoint Dialog screen, select and edit the desired setpoint(s).

## M-2001C “SimpleStart” Initial Setup Instructions Cont’d

- b) Select **Write To Control**, TapTalk will respond with a confirmation screen that states: “Setpoints have been successfully written to the control.”
- c) Select **Exit**.

### **Data Logging**

The control data logger has been preset to automatically begin collecting partial data when power is applied to the control. If changes to the values to be logged or the logging interval are desired, then proceed as follows:

1. From the TapTalk drop down menu, select **Utilities/Data Logging/Control Setup and Download**. The Data Logging Control Setup and Download dialog screen will be displayed.
2. When all Data Logging and Download parameters have been set, then perform the following:
  - a) Select **Erase Existing Data and Start Logging data to Control**.
  - b) Select **Yes** to confirm.
  - c) Select **OK** to close the Data Logging Control Setup and Download dialog screen.



**This Page Left Intentionally Blank**

# TABLE OF CONTENTS

## M-2001C (BASE-R Version)

### Instruction Book

#### Chapter 1 Introduction

1.0	Description .....	1-1
1.1	Adapter Panel/Surface Mounting Kit .....	1-1
1.2	Accessories .....	1-2
	M-2029A TapTalk® Communications Software .....	1-2

#### Chapter 2 Front Panel Controls

2.0	Introduction .....	2-1
2.1	Display/Tapchanger Control .....	2-1
2.2	User Interface Controls .....	2-2
2.3	Status Indicators .....	2-2

#### Chapter 3 Setting The Control

3.0	Introduction .....	3-1
3.1	Passwords .....	3-1
3.2	Voltage Regulation .....	3-2
	Standard Control Settings .....	3-2
	Voltage Regulation Without LDC .....	3-2
	Bandcenter (BC) .....	3-2
	Bandwidth (BW) .....	3-2
	Time Delay (TD) .....	3-2
	Voltage Regulation With LDC .....	3-4
	LDC X/R .....	3-4
	LDC-Z .....	3-5
3.3	Voltage Reduction .....	3-5
3.4	Regulation Limits .....	3-5
	Overvoltage Limit & Voltage Runback .....	3-5
	Undervoltage Block .....	3-6
	Coordination with Backup Relay .....	3-6
	Tap Position Block .....	3-6
	Overcurrent Block Operation .....	3-6
3.5	Pulsed Output .....	3-6
3.6	Application Considerations .....	3-7
	Sequential .....	3-7
	Intertap Time Delay .....	3-7
	Test Mode/Status Screen .....	3-7

## Chapter 4 Configuration

4.0	Introduction .....	4-1
4.1	Passwords .....	4-1
	Initializing Passwords (Control) .....	4-1
	Configuring Passwords .....	4-2
	Disabling Passwords .....	4-2
	Configuration Changes .....	4-2
4.2	User Identification .....	4-2
4.3	Counters .....	4-2
4.4	Correction Factors .....	4-3
	VT Ratio Correction .....	4-3
	CT/VT Phase Shift .....	4-3
4.5	Ratio Multipliers .....	4-4
4.6	Tap Information .....	4-4
	Tap Position By Keep Track (Reg Internal) .....	4-4
4.7	Reverse Power Operation .....	4-6
4.8	Output Selection .....	4-7
4.9	Protocols/Communication .....	4-7
4.10	Basic Timer Types .....	4-7
4.11	Data Logging .....	4-7
4.12	Current Display/Scaling .....	4-8
4.13	Regulator Type .....	4-9

## Chapter 5 Status

5.0	Introduction .....	5-1
5.1	Metering .....	5-1
	Secondary .....	5-1
	Primary .....	5-1
	Demand Metering .....	5-3
	Quantitative Metering .....	5-3
5.2	Drag-Hand Display Quantities .....	5-3
5.3	Real-Time Clock .....	5-3
5.4	Line Frequency .....	5-3
5.5	Voltage Reduction Status .....	5-4
5.6	Removal of Select Status Screens .....	5-4

**Chapter 6 Connections**

6.0	Installation .....	6-1
6.1	External Connections .....	6-1
6.2	Multi-Step Voltage Reduction .....	6-5
6.3	Backup Control .....	6-6
6.4	Communication Port .....	6-6
6.5	Grounding .....	6-6
6.6	Typical Regulator Connection .....	6-6

**Chapter 7 Test Procedure**

7.0	Set-up Procedure .....	7-1
7.1	Bench Test .....	7-3
	Resistance .....	7-3
	Reactance .....	7-3
	Voltage Reduction .....	7-3
	Counter .....	7-3
	Block Raise/Block Lower/Deadband .....	7-4
7.2	Check-out Procedure .....	7-4
7.3	Operational Test .....	7-5
7.4	In-Service Test .....	7-5

**Chapter 8 Design Changes**

8.0	Design Changes .....	8-1
-----	----------------------	-----

**Chapter 9 TapTalk® Communications Software**

9.0	Availability .....	9-2
9.1	Hardware Requirements .....	9-2
9.2	Installing TapTalk .....	9-2
9.3	Communication using Direct Serial Connection .....	9-3
9.4	Communications using a Modem .....	9-4
	Configuring the Control for Communication using a Modem .....	9-4
	Configuring TapTalk for Communication using a Modem .....	9-5
9.5	Communications with Multiple Controls .....	9-6
9.6	Cautions .....	9-7
9.7	Overview of Operation .....	9-9
	File .....	9-9
	Communication .....	9-10
	Multiple Control Addressing .....	9-13
	Control Settings .....	9-13
	Set Timers .....	9-14
	Control Setup .....	9-15

**Chapter 9 TapTalk® Communications Software (cont)**

	Control Setup/Setpoints .....	9-15
	Control Setup/Configuration .....	9-18
	Control Setup/DNP Configurations .....	9-20
	Control Monitor .....	9-21
	Control Monitor/Status .....	9-21
	Control Monitor/Demand Metering .....	9-25
	Control Monitor/Energy Metering .....	9-26
	Control Monitor/Harmonic Analysis .....	9-27
	Control Monitor/Tap Changed Statistic .....	9-28
	Utilities .....	9-29
	Remote Control .....	9-29
	Remote Control and Automatic Mode Blocking .....	9-29
	Restoring Automatic Operation (Local) .....	9-29
	Utilities/Data Logging .....	9-32
	Data Logging/Control Setup and Download .....	9-32
	Data Logging/to PC .....	9-33
	Utilities/Control Information .....	9-34
	Utilities/Set Control Date and Time .....	9-34
	Utilities/Set User Lines .....	9-35
	Utilities/Set New User Passwords .....	9-35
	Window .....	9-36
	Help .....	9-36
	Help/Instruction Book .....	9-36
	Help/About M-2029A .....	9-36
9.8	Communication Cables .....	9-37
9.9	M-2829 TapPlot™ Analysis Software .....	9-39

**Appendix A**

A.0	Summary of Specifications .....	A-1
A.1	External Connections .....	A-1
A.2	Field Checkout Procedure .....	A-1
A.3	Screen Review .....	A-3
A.4	Setpoint and Configuration Worksheets .....	A-14

**Appendix B**

.....	B-1
-------	-----

Figures	Page
<b>Chapter 1 Introduction</b>	
1-1 Functional Diagram .....	1-2
1-2 Typical Adapter Panel Mounting .....	1-3
<b>Chapter 2 Front Panel Controls</b>	
2-1 M-2001C (BASE-R) Tapchanger Control .....	2-3
<b>Chapter 3 Setting the Control</b>	
3-1 Inverse Time Delay Curve .....	3-3
3-2 Local Voltage as Function of Load Current When Using Line Drop Compensation/Action of Overvoltage and Overvoltage Runback Control .....	3-8
<b>Chapter 4 Configuration</b>	
4-1 Regulator Type .....	4-9
<b>Chapter 5 Status</b>	
5-1 Secondary Quantity Metering and Primary Quantity Calculations for Regulator Applications .....	5-2
5-2 Secondary Quantity Metering and Primary Quantity Calculations for Transformer Applications .....	5-2
<b>Chapter 6 Connections</b>	
6-1 Typical M-2001C (BASE-R) Stand-Alone Connections .....	6-2
6-2 External Connections .....	6-3
6-3 M-2001C (BASE-R) and LTC Transformer Control Typical Connections .....	6-7
6-4 M-2001C (BASE-R) and Regulator Control Typical Connections .....	6-8
<b>Chapter 7 Test Procedure</b>	
7-1 External Connections for Test Procedure .....	7-2
7-2 Setup For Current Checkout Procedure .....	7-5

Figures (cont)	Page
<b>Chapter 9 TapTalk® Communications Software</b>	
9-1 TapTalk Program-Item Icon .....	9-3
9-2 Modem Plug and Play Properties Dialog Screen .....	9-5
9-3 Modem Plug and Play Connection Dialog Screen .....	9-6
9-4 Multiple Control Addressing using Communications Line Splitter .....	9-8
9-5 TapTalk Menu Selections .....	9-9
9-6 File Information Dialog Screen .....	9-10
9-7 File Name Options Screen .....	9-10
9-8 Communication Access (Serial) Dialog .....	9-10
9-9 Communication Access (Modem) Dialog .....	9-11
9-10 Modem Communication Setup .....	9-11
9-11 Edit Phone Book Dialog .....	9-12
9-12 Terminal Window .....	9-12
9-13 TCP/IP Communications Setup .....	9-12
9-14 Communication to New Control Address Dialog Screen .....	9-13
9-15 Control Settings Dialog Screen .....	9-13
9-16 Set Communication Timers Screen .....	9-14
9-17 Setpoints Dialog Screen .....	9-16
9-18 Configuration Dialog Screen .....	9-18
9-19 Status Screen .....	9-21
9-20 Demand Metering Dialog .....	9-24
9-21 Energy Metering Screen .....	9-26
9-22 Harmonic Analysis Dialog Screen .....	9-27
9-23 Tap Changes Statistic Screen .....	9-28
9-24 Remote Control Screen .....	9-30
9-25 Data Logging to Control Dialog Screen .....	9-32
9-26 Data Logging to PC Dialog Screen .....	9-33
9-27 Control Information Screen .....	9-34
9-28 Set Control Date and Time Dialog Screen .....	9-34
9-29 Set User Lines Dialog Screen .....	9-35

Figures (cont)	Page
<b>Chapter 9 TapTalk® Communications Software (cont)</b>	
9-30 New Passwords Setup Dialog Screen .....	9-35
9-31 New User Level Password Confirmation Screen .....	9-35
9-32 Remove Status Screens Selection Screen .....	9-36
9-33 Null Modem Cable 9-pin to 9-pin .....	9-37
9-34 Null Modem Cable 9-pin to 25-pin .....	9-37
9-35 Modem Cable 9-pin to 25-pin .....	9-38
9-36 TapPlot Program-Item Icon .....	9-39
9-37 TapPlot Window and Tap Data Example .....	9-40
9-38 TapPlot Screen with Callouts .....	9-41
9-39 TapPlot Submenu Callouts .....	9-42
9-40 Device Information Screen .....	9-43
9-41 Select Waveform Dialog Screen .....	9-44
9-42 Select Color Dialog Screen .....	9-44
9-43 About TapPlot Screen .....	9-44
<b>Appendix A</b>	
A-1 Software Menu Flow .....	A-3
A-2 Status Screens .....	A-4
A-3 Bias Test Voltage Screen .....	A-7
A-4 Setpoint Screens .....	A-8
A-5 Configuration Screens .....	A-10
A-6 Setpoint Worksheet .....	A-14
A-7 Configuration Worksheet .....	A-15
<b>Appendix B</b>	
B-1 Data Output .....	B-2



**Chapter 3 Setting the Control**

3-1	Bandcenter, Bandwidth, Time Delay and Line Drop Compensation Setpoint Ranges .....	3-3
3-2	Approximate Ratio of Line Reactance to Resistance (X/R) of Typical Distribution Circuits .....	3-4
3-3	Intertap Time Delay Setpoint Range .....	3-7

**Chapter 4 Configuration**

4-1	Tap Information Screen Selections .....	4-5
-----	---	-----

**Chapter 6 Connections**

6-1	Multi-Step Voltage Reduction External Connections .....	6-6
-----	---	-----

**Chapter 7 Test Procedure**

7-1	Initial Settings .....	7-1
-----	------------------------	-----

# 1 Introduction

1.0	Description .....	1-1
1.1	Adapter Panel/Surface Mounting Kit .....	1-1
1.2	Accessories .....	1-2

---

## 1.0 Description

---

The M-2001C (BASE-R) Digital Tapchanger Control is a microcontroller-based transformer and step-voltage regulator load tapchanger control.

The control is normally supplied with a separate adapter panel that is designed for initial OEM installation on new transformers or to replace a particular manufacturer's tapchanger control. The panel is designed to mechanically and electrically replace an old control, with matching mounting hardware to facilitate the replacement. See Figure 1-2, Typical Adapter Panel Mounting.

Interrogation of the control and setting changes are made through the user interface (HMI), or through the communications port (COM2.) User interface consists of a 20-character by 2-line display and four pushbuttons. Two passwords available to the user are accessed by the buttons and a third is accessed through the communications port. All setpoints are stored in non-volatile memory which is unaffected by control voltage disturbances.

Two operation counters are provided. One counter may be reset; the other may be pre-set by the user.

Eight LEDs are used to indicate Tapchanger Raise and Lower command status, Reverse Power detection, CPU OK, LDC In Effect, V/RED Voltage

Reduction in Effect, MANUAL Control (Auto Operation Blocked Via Comm or Front Panel), LOCAL (SCADA Control Blocked Locally) and COM1 TX and RX. The LOCAL and COM1 TX/RX LEDs are not functional on the BASE-R control.

The control uses a Motorola microcontroller which has a self-testing watchdog system. Refer to Figure 1-1 for the functional diagram. The alphanumeric display and four-button interface provides complete front panel access to the scrolling menu program shown in the Appendix, Figure A-1. The control applies to tapchanger designs with many configurations of taps (e.g.,  $\pm 16$  taps, 1 to 17 taps, 0 to 33 taps, etc.).

---

## 1.1 Adapter Panel/ Surface Mounting Kit

---

An adapter panel *or* an M-2050 or M-2054 Surface Mounting Kit *must* be used with the M-2001C Tapchanger Control. Each panel adapts the M-2001C as a transformer and regulator control replacement and provides the external connections necessary for operation via terminal blocks on the rear of the adapter panel. Contact Beckwith Electric for a list of adapter panels that are currently available. Refer to the Application Guides of the specific adapter panel for the mounting details. See Figure 1-2 for a typical adapter panel mounting.

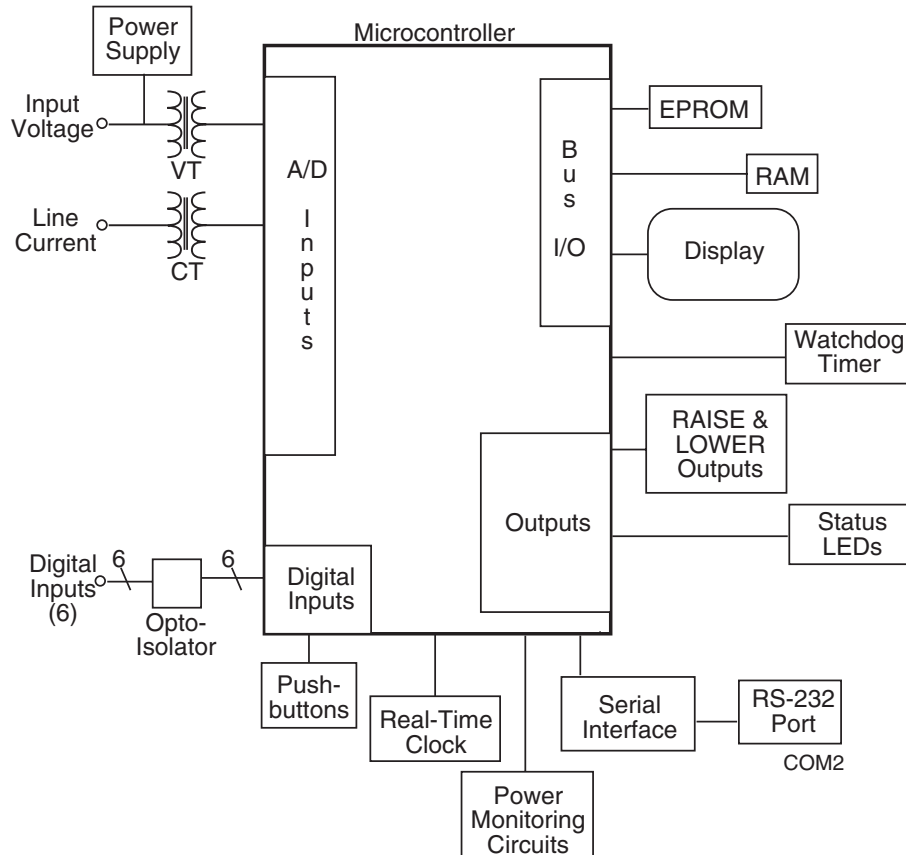

Figure 1-1 Functional Diagram

The M-2050 is an adapter kit which permits surface mounting of the control using two right angle mounting brackets, four screws and a 24-pin connector with six-foot pigtailed on each pin. The M-2050 does *not* include features available on adapter panels. These features include mechanical configurations and wiring connections for direct replacement, CT shorting or front panel switches, fuses or test points. Refer to the Instruction Manual of the M-2050 for the mounting details.

The M-2054 is an adapter kit which permits surface mounting of the control using two right angle mounting brackets, four screws and a 24-pin connector with six-foot pigtailed on each pin. Refer to the Instruction Manual of the M-2054 for the mounting details and additional information.

## 1.2 Accessories

### M-2029A TapTalk® Communications Software

TapTalk is a Windows-based communications software program available for remote control and metering of the M-2001C (BASE-R) Tapchanger Control. It is designed to interface with the

microcontroller of the control through an RS-232 port (COM2.) The RS-232 port supports baud rates up to 19200 bps. The M-2029A software displays all pertinent operating information. All operations that can be performed from the front panel user interface of the control can be duplicated remotely, through M-2029A. These operations include:

- Changing setpoint values. (This includes those values for normal tapchanger control operation, as well as custom configuration to the site.)
- Observing values. (This includes measured and calculated values of real-time operating parameters.)
- Data logging. The control can internally store various parameters at selected intervals. The M-2029A program can download this data into an Excel® spreadsheet and display. Alternatively, the PC can be programmed to poll the control and obtain a pre-selected list of parameters at selected intervals.

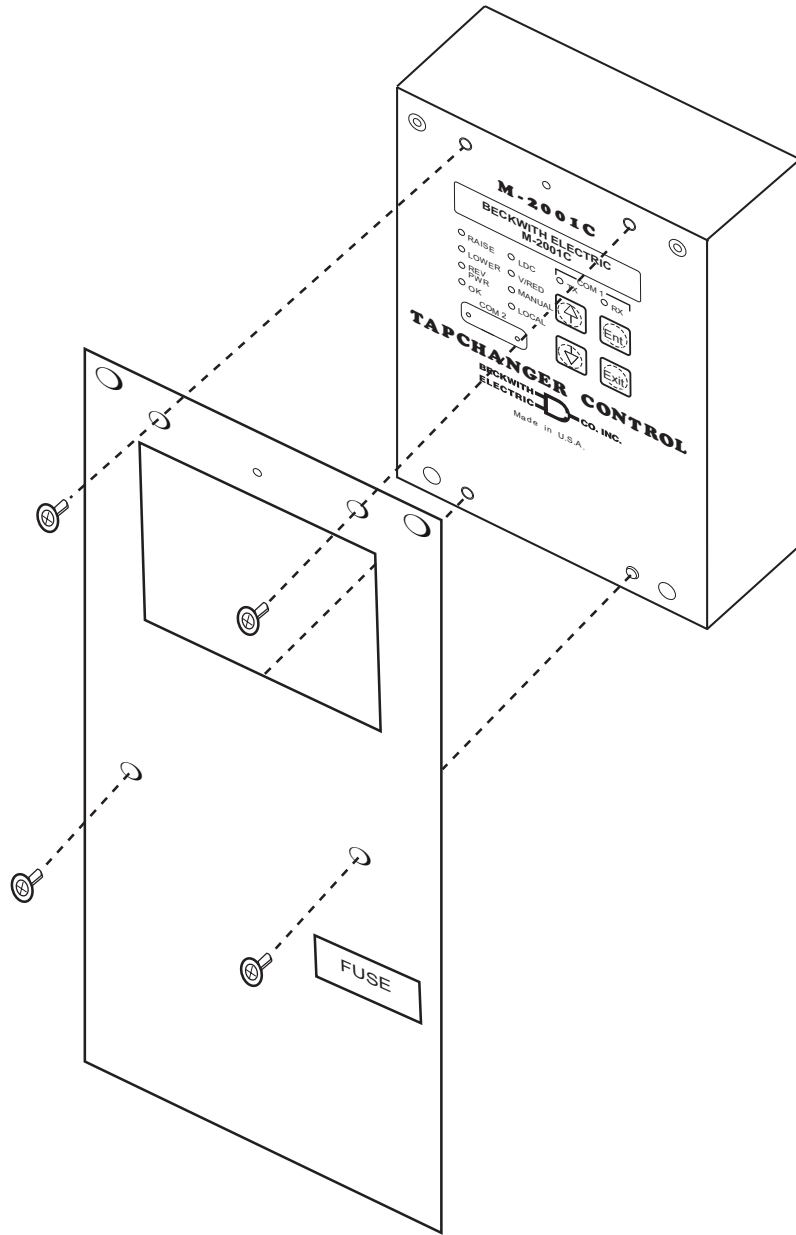

Figure 1-2 Typical Adapter Panel Mounting

**This Page Left Intentionally Blank**

# 2 Front Panel Controls

2.0	Introduction .....	2-1
2.1	Display/Tapchanger Control .....	2-1
2.2	User Interface Controls .....	2-2
2.3	Status Indicators .....	2-2

---

## 2.0 Introduction

---

The front-panel user interface consists of a standard Liquid Crystal Display (LCD) or optional Vacuum Fluorescent Display (VFD), **↑**, **↓**, **EXIT**, and **ENT** pushbuttons, status indicators, and the control switches as shown in Figure 2-1, M-2001C (BASE-R) Front Panel.

---

## 2.1 Display/Tapchanger Control

---

The display shows the desired function and its current status or setpoint value. The function is displayed on the top line, and the bottom line displays its current status. The display is normally blank and remains so until the **↑**, **↓**, or **ENT** pushbutton is depressed. Pressing any pushbutton will display the User Lines screen, and then the Local Voltage screen.

### Power Up Screens

Each time the control is powered up, it will briefly display a series of screens that include:

- Beckwith Electric M-2001C (BASE-R)
- Serial Number
- Control Firmware Number
- Date
- Time of Day
- User Lines

### Screen Blanking

The display automatically goes blank after exiting from any menu, or from any screen after 15 minutes of unattended operation. Manual screen blanking is accomplished by pressing the **EXIT** pushbutton.

### Flashing C “CHANGE” Prompt

This prompt, in the bottom right corner of a screen, is enabled by initially pressing **ENT**. This prompt indicates that the user can change a setting using the **↑** or **↓** pushbuttons to increment or decrement the settings. Values have factory preset increments, such as 0.1 volt or 1 second. Press **ENT** the second time to execute the setting change.

### “ENT” Prompt

When the “**E**” prompt appears in the top right corner of the drag-hand parameter screens, operation counter reset screen, and demand metering screen, it indicates that the value of display will reset if the **ENT** pushbutton is pressed.

---

## 2.2 User Interface Controls

---

### ↑ and ↓ Pushbuttons

The ↑ and ↓ pushbuttons have two functions. First, they are used to change screens and scroll through selections. Second, they are used to enter new values by incrementing or decrementing the displayed value. The new value is not stored until the **ENT** pushbutton is pressed a second time.

Pressing the ↑ or ↓ pushbutton for longer than one second will cause faster scrolling, either when selecting screens or when selecting setpoint values.

### ENT Pushbutton

The **ENT** pushbutton is used to perform the following functions:

- Enter the change mode of a screen
- Store a setpoint or condition in memory
- Enter an access code
- Reset certain status screens

When entering an access code, the **ENT** pushbutton will move the cursor (an underline) to the selected digit location and the ↑ or ↓ pushbutton will change the value. When the final digit is selected, and “**C**” is flashing, the new access code is entered using the **ENT** pushbutton.

In some cases, it is desirable to leave a screen without making a change. In selecting setpoints or settings, wait 20 seconds without pressing the **ENT** pushbutton and the “**C**” will stop flashing. At that point, the ↑ and ↓ pushbuttons will again change screens rather than scroll the previous setpoint number or setting choice. The previous changes of that screen will not be recorded and the older setpoints or configuration choices will still be in effect.

When setting passwords, programmable alarm function or user lines in the Configuration Menu, the 20-second time-out is not functional and the user cannot cancel once a new entry has been started.

### EXIT Pushbutton

The **EXIT** pushbutton is used to exit from any screen, causing the display to go blank. If **EXIT** is selected while the “**C**” is flashing, the control will exit without keeping the changed setting.

---

## 2.3 Status Indicators

---

### RAISE LED

The red LED indicates when the voltage is below the lower band edge and the timer has started timing for a tapchanger raise operation.

### LOWER LED

The red LED indicates that the voltage is above the upper band edge and the timer has started timing for a tapchanger lower operation.

### REV PWR LED

The red LED will light to indicate when the unit detects reverse power flow.

### OK LED

The green LED light will remain lit whenever power is applied to the unit and the watchdog circuit indicates the microcontroller is working properly.

### LDC LED

The yellow LED will illuminate when any non-zero setting has been entered as LDC Fwd resistance or reactance, or LDC-Z. It will also illuminate when any non-zero setting has been entered as LDC Rev resistance or reactance with the “Rev Power Oper” configuration set to “regulate in Reverse” and the control in reverse power mode.

### V/RED LED

The yellow LED will illuminate when any level of voltage reduction has been invoked. This is true for any voltage reduction process whether it came from an external contact or any Com input.

### MANUAL LED

The yellow LED will illuminate when Auto Operation of the control has been blocked from any COM port. It will also illuminate when Manual Mode has been selected using the Adapter Panel Auto/Manual Pushbutton or toggle switch.

### LOCAL LED

This LED is not functional on the BASE-R version.

### COM1 TX/RX LEDs

These LEDs are not functional on the BASE-R version.

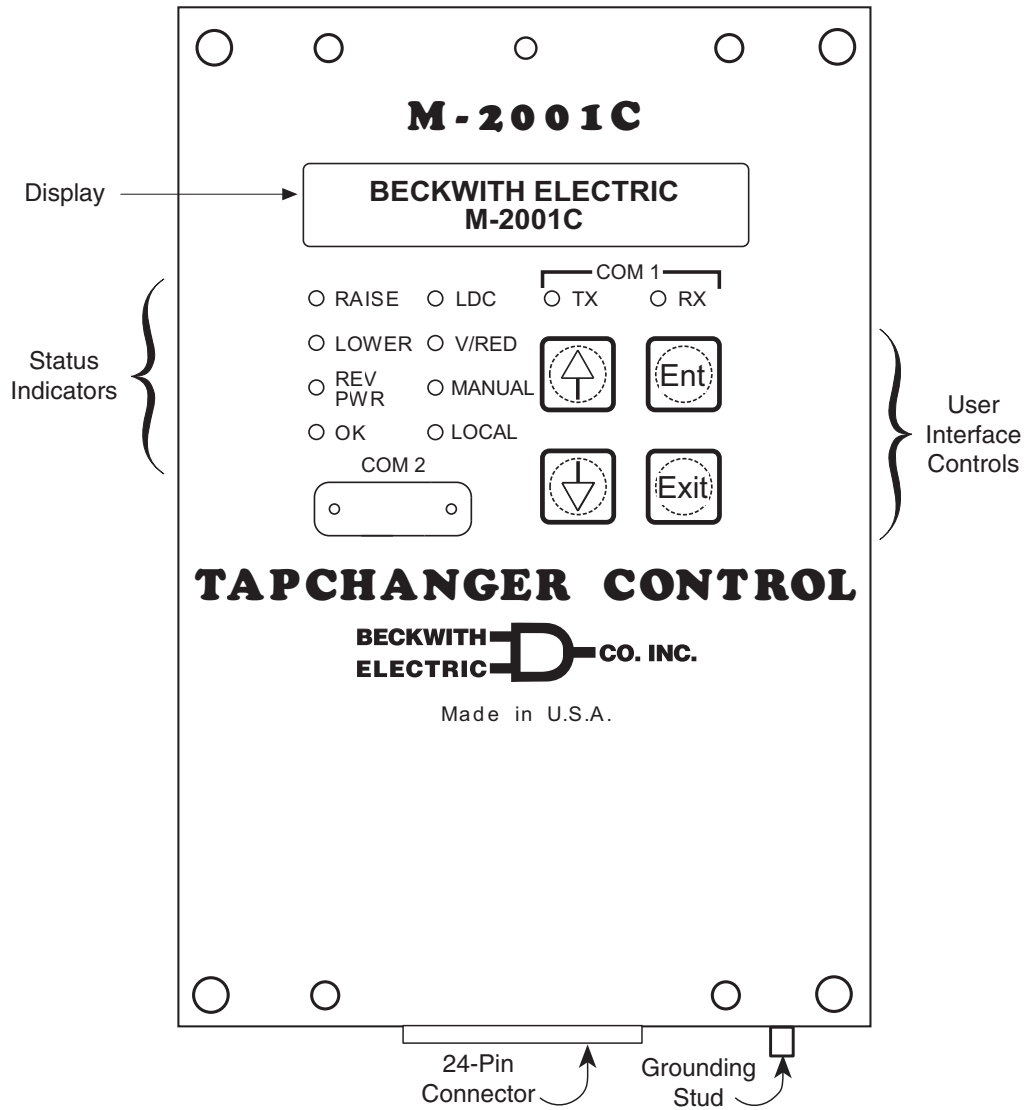

Figure 2-1 M-2001C (BASE-R) Tapchanger Control



**This Page Left Intentionally Blank**

# 3 Setting The Control

3.0	Introduction .....	3-1
3.1	Passwords .....	3-1
3.2	Voltage Regulation .....	3-2
3.3	Voltage Reduction .....	3-5
3.4	Regulation Limits .....	3-5
3.5	Pulsed Output.....	3-6
3.6	Application Considerations .....	3-7

---

## 3.0 Introduction

---

If the control will not execute Raise or Lower operations due to remote blocking using M-2029A TapTalk®, front panel operation can be restored by using the Remote Control screen to remove the block, or momentarily removing power from the control. In order to restore front panel operation, the Save Comm Block at Power Off configuration setting must be set to Disable.

Local and remote control may be used at the same time by designating “Local Mode” disabled in the Configuration menu.

### Settings Entry

Use the **↑** and **↓** pushbuttons to scroll to the desired setpoint entry screen and press **ENT** to enter the change mode. A password is required for entry into change mode, unless the Level 1 password has been disabled. Use the **↑**, **↓** and **ENT** pushbuttons to change the setting.

When the control is first energized, the quickest way to properly initialize the control prior to entering the setpoints is to set the real-time clock. This action will initiate a prompt from the control to

perform a reset operation for the following items:

- Demand Metering
- Energy Metering
- Drag Hands Reset Registers
- Resettable Operations Counter

It is then easy to proceed with the remainder of the control setup.

---

## 3.1 Passwords

---

### Password Access Screens

To prevent unauthorized access to the control functions, there are provisions in the software for assigning up to three passwords. Two are for use with the front panel controls and one is for use with the communication interface. The passwords can be set in the Configuration Menu. For more information, refer to the **Passwords** section of the **Configuration** chapter.

### Access Levels

General access to read setpoints, to monitor status, to reset drag-hand parameters and the resettable operations counter do not require a password.

The **Level 1** password, if set, is required to make local setting changes including the date and time of day. If the Level 1 password is set to all zeros, this request for a password will not be seen and changes can be made without a password.

The **Level 2** password, if set, is required to make changes to the configuration, passwords, and user identification. If the Level 2 password is set to all zeros, this request for a password will not be seen and changes can be made without a password.

The **COMM** password is for use with the M-2029A TapTalk® Communications Software. This password provides secure remote operation. If the communications password is set to all zeros in the M-2001C (BASE-R) Digital Tapchanger Control, the communications program will not ask for a password.

**● WARNING: Please record all passwords in a secure location. If the password is lost or forgotten, please contact the factory.**

---

## 3.2 Voltage Regulation

---

### Standard Control Settings

Refer to the Appendix, Figure A-4. With the Level 1 password, six forward and six reverse setpoints are available (see Table 3-1) from the Setpoint Menu. They are: bandcenter, bandwidth, time delay, inverse time, and line drop compensation resistance and reactance for each direction and Z-compensation.

The control will send commands to the tapchanger to change taps as needed to hold the voltage within the bandwidth setting as modified by the line drop compensation settings and by paralleling.

The control will only respond to an out-of-band voltage excursion after the timer has reached the time delay setting. The timer can be set as an integrating timer or an instantaneous reset timer upon the voltage return to an in-band condition. As an integrating timer, it increments during time out-of-band and decrements during time in band, but not below zero.

### Voltage Regulation Without LDC

When the control is just used to regulate the voltage on the transformer or regulator low-side bus, the only input required is voltage from a line-to-line or line-to-ground VT with a nominal 120 V ac secondary.

### Bandcenter (BC)

The center of the voltage band is adjustable from 100 to 135 V ac in 0.1 volt increments (for example, 120 V ac).

### Bandwidth (BW)

The LTC uses discrete steps and the Bandwidth must have a width that allows at least one tapchange position where the control remains satisfied. To minimize excessive operations on the tapchanger, this bandwidth is usually set to include two or three in-band tap operation positions.

The range is settable from 1 to 10 volts in 0.1 volt increments, and 2 volts minimum is recommended. This setting is the total bandwidth.

### Time Delay (TD)

The time delay setting is needed to inhibit the tapchanger from unnecessary operations on temporary voltage excursions and is commonly set at 30 to 60 seconds.

The control has two types of timers for time delay: definite time and inverse time. The kind of time delay the control will use depends on the setting found in the configuration menu called **TIMER SELECTION**. Both types of delay will work in forward or reverse power flow. The inverse time delay will follow the curve in Figure 3-1, Inverse Time Delay Curve.

#### *Inverse Time Example*

Bandcenter 120 V

Bandwidth 3 V

Inverse Time Delay Setting 120 s

$$\Delta V = (\text{Bandwidth}/2) = 1.5 \text{ V}$$

$$V_{in} = 123 \text{ V}$$

Voltage deviation in multiples of  $\Delta V$

$$= [V_{in} - \text{Bandcenter}]/\Delta V$$

$$= (123 - 120)/1.5$$

$$= 2$$

Time delay from Figure 3-1

$$= 50\% \text{ of Inverse Time Delay setting}$$

$$= 60 \text{ sec.}$$

Function	Setpoint Range	Increment	Default Setting
Bandcenter	100.0 V to 135.0 V	0.1 V	120.0 V
Bandwidth	1.0 V to 10.0 V	0.1 V	2.0 V
Time Delay	1 Second to 120 Seconds	1 Second	30 Seconds
Inverse Time Delay	1 Second to 120 Seconds	1 Second	30 Seconds
LDC Resistance	-24 V to +24 V	1 V	0 V
LDC Reactance	-24 V to +24 V	1 V	0 V
LDC-Z	0 V to 24 V	1 V	0 V

Table 3-1 Bandcenter, Bandwidth, Time Delay & Line Drop Compensation Setpoint Ranges

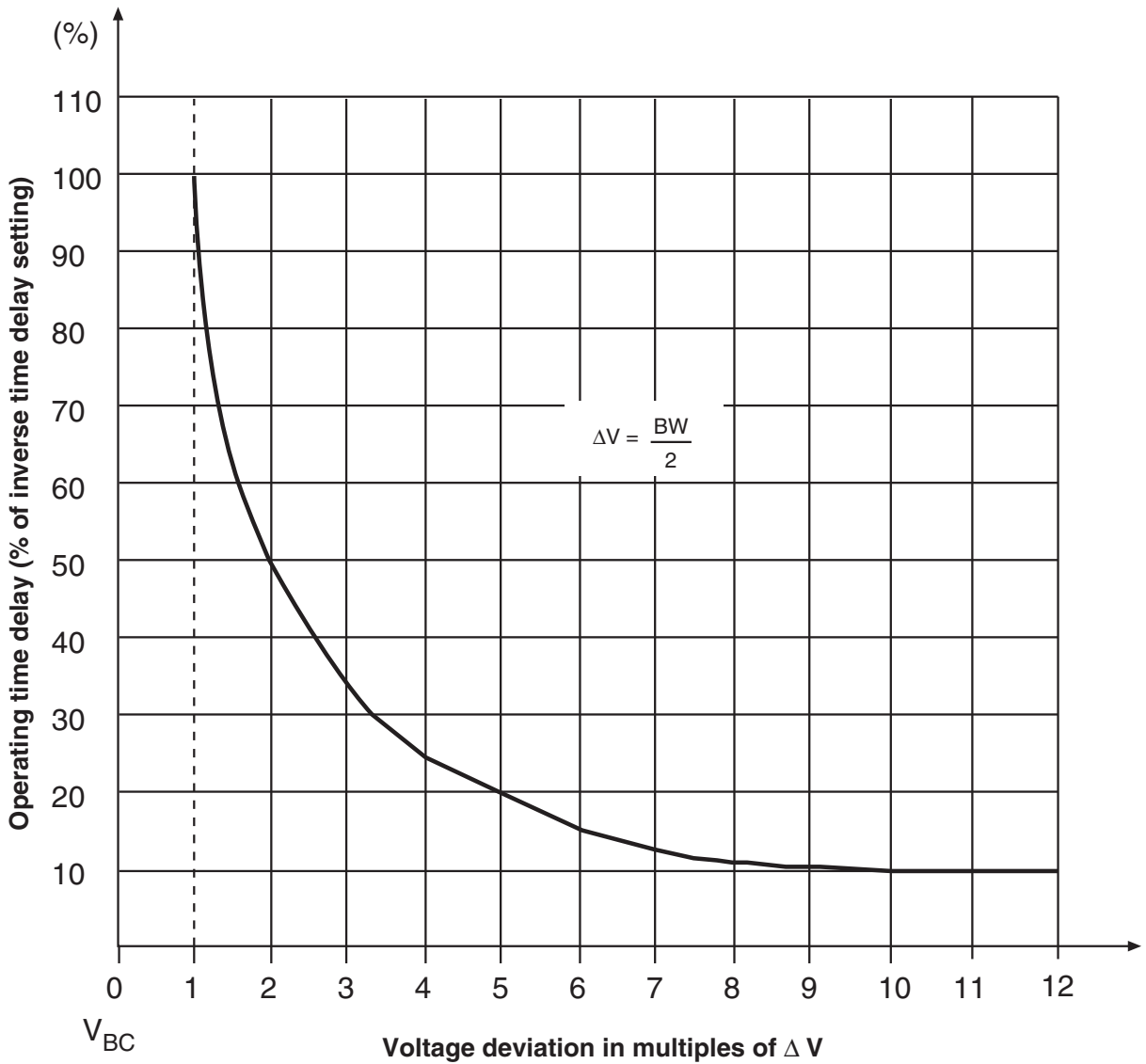

Figure 3-1 Inverse Time Delay Curve

### Voltage Regulation with LDC

When it is desirable to regulate the voltage at some distance from the transformer or voltage regulator, or in general to raise the voltage during high load conditions, the Line Drop Compensation (LDC) feature is used.

Two different LDC methods are available in the M-2001C (BASE-R) Digital Tapchanger Control. A configuration setpoint called LDC Selection allows the user to select from either of these methods.

The Bandcenter, Bandwidth, and Time Delay functions are set the same as if LDC were not used.

### LDC X/R

A classical approach can be used to determine the X/R settings for the LDC, however this assumes a load center point and is usually not applicable to the typical distribution feeder. For more information, contact Beckwith Electric for **Application Note #17**.

A simpler method, which will work for most applications, is recommended. This involves looking at the lines leaving the station and determining the reactance/resistance (X/R) ratio for the main line. The reactive and resistive line drop compensation setpoints should then be entered in this same X/R ratio.

If the CT and VT phasing corrections have been made to remove any phase angles between measured voltage and live current, only positive values of R and X compensation need to be used.

Table 3-2 gives the X/R ratio for various wire sizes and typical conductor spacings.

By knowing the ratio of the maximum expected load to the present load, the amount of voltage compensation needed is found as shown in the following example.

*Example*

**Desired**

- local voltage @ min load = 120 volts
- local voltage @ max load = 124 volts

Using the following assumptions:

- Desired Bandcenter = 120 volts
- Desired Bandwidth = 2 volts
- The device being controlled is 50% loaded

### Setting

Start with R=0 and X=0 and increase both values using the ratio shown in the table for the feeder conductor. Keeping the X/R ratio, increase R<sub>set</sub> and X<sub>set</sub> until the difference between the compensated voltage and the local voltage is 2.0 volts.

This example would let the voltage vary from 119 V at no load to 125 V at maximum load taking into account the bandwidth.

With this simplified method of LDC setting, the first customer's voltage will be limited by the upper voltage limit at the highest daily load, depending on the accuracy of the daily load projection. At the same time, the furthest customer will receive the highest voltage possible under the line and loading conditions. The first customer protection can be set on the control. Refer to the **Regulation Limits** section of this chapter.

Since the daily load projections will likely have a seasonal variation, the best balance of first customer to furthest customer voltage may require seasonal adjustment of the LDC settings. Note that the settings of R and X compensation are proportional to the peak load projection and that new settings can be scaled from the first setting obtained by the experimental process just described.

ACSR		COPPER	
MCM	X/R	MCM	X/R
795	4.0	750	6.0
477	2.5	500	4.5
336	2.0	350	3.3
266	1.5	250	2.4
AWG	X/R	AWG	X/R
4/0	1.2	4/0	2.0
2/0	1.0	2/0	1.5
2	0.5	2	0.7
6	0.2	6	0.3

*Table 3-2 Approximate Ratio of Line Reactance to Resistance (X/R) of Typical Distribution Circuits*

### LDC-Z

The second available compensation method is called Z-compensation (LDC-Z). LDC-Z must be selected in the control configuration portion of the menu or software and the **VOLTAGE RAISE** ( $V_R$ ) setpoint must be set in order for this feature to be implemented. The LDC-Z application is especially useful on systems where several lines exist with different load centers where the proper compensation is not related to any single R & X values as set in R & X compensation.

Basically, LDC-Z compensation consists of designating a target bus voltage increase (line drop compensation) that correlates to the **magnitude** of the control current rather than to the calculation of input R & X line drop at control current magnitude and angle values.

The setting, ( $V_R$ ), is the calculated line voltage drop (at maximum load) in the circuit or line that has the highest voltage drop at maximum load condition - ratio'd to the rated CT output (200 ma).

$V_R = 0$  to 24 volts in increments of 1 volt.

Example:

- Calculated voltage drop = 5 volts at load level of 150 ma control current.
- $V_R$  setting =  $200/150 \times 5 = 6.7$  volts (rounded) = 7 volts

To calculate the line drop compensation at any given control current level (I):

- $V = I/200 \times 7$  (setting):  
If  $I = 50$  ma;  $V = 50/200 \times 7 = 1.75$  volts

As with R & X compensation applications, the “block raise” and “deadband” settings are used for first house protection on all circuits or lines.

■ **NOTE:** For additional information about LDC-Z applications, contact Beckwith Electric to obtain Distributech Paper 1/27/05, “*Maximizing Automatic Reverse Power Operations with LTC Transformers and Regulators.*”

---

### 3.3 Voltage Reduction

---

Refer to the Appendix, Figure A-4. The control allows three steps of voltage reduction via external dry contacts or by serial port connection. The percentage voltage reduction at each step is adjustable from 0 to 10% in 0.1% increments. When one or more contacts are closed, the effect is to shift the bandcenter setpoint lower thus causing the LTC to lower the voltage.

Recognize that the “effective” bandcenter may have been raised by line drop compensator action when the voltage reduction is initiated and that the resultant voltage setting will be the combination of the two effects. Note also that the undervoltage block setting may limit the lowering of voltage, especially if there is little raising of the local voltage due to LDC action.

When first initiated, or when a subsequent step of voltage reduction is needed, the control will respond immediately to the voltage reduction command without regard to either the intertap time delay setting or the control time delay setting. After the desired voltage reduction, operation will revert back to normal operation with the time delay. Refer to Section 6, Connections, for contact connections.

Wired SCADA dry contacts or serial port connection can be used to provide stepped voltage reduction as described earlier. However, these should *not* be used together, since the resulting reduction would be the combination of the inputs.

---

### 3.4 Regulation Limits

---

#### Overvoltage Limit & Voltage Runback

Refer to the Appendix, Figure A-4. Setpoints are available to establish a block raise limit and voltage runback. The overvoltage limit is adjustable from 95.0 V to 135.0 V in 0.1 V increments. The overvoltage limit must be set above the upper control band limit. This limit is one portion of the First Customer Protector to limit overvoltage from line drop compensation action during heavy loading.

The voltage runback level is the Block Raise setting plus the Dead Band setting (this establishes the First Customer Protection level.) This deadband should not be confused with the control deadband above and below the center voltage setpoint, which is generally called the control “bandwidth”.

The voltage runback deadband is used to assure that the runback setting is sufficiently above the upper voltage limit setting to limit hunting. It is adjustable from 1.0 to 4.0 V in 0.1 V increments, and must be set greater than the voltage change of one single tapchange, or hunting will occur. It is suggested it be set for approximately twice the voltage change of one tap.

If the voltage exceeds the runback limit, as might be caused by combinations of LDC action and load shifts or by a system disturbance without LDC action, the control will immediately call for an “automatic” lower without any time delay. The lower command will continue until the voltage is reduced below the runback voltage limit. After this occurs,

the timer will reset. If the voltage is still high, normal control action will bring the voltage down to within the normal control band.

Overvoltage block can be effectively disabled by setting it to 135 V. By setting the runback deadband to 4 V, the runback voltage becomes 139 V which effectively disables the feature.

### Undervoltage Block

Refer to the Appendix, Figure A-4. This limit is adjustable from 95.0 V–135.0 V in 0.1 V increments. This limit can be set to limit low customer voltage to safe limits and will block voltage reduction action that could cause motor stalling and other undesirable low voltage effects. Undervoltage block can be effectively disabled by setting it to 95 volts. If the voltage is below the Block Lower setpoint, the control will not respond to further lower commands. Raise commands are not affected. Operation of the overvoltage limit, voltage runback and undervoltage block is illustrated in Figure 3-2.

### Coordination with Backup Relay

The M-2001C (BASE-R) Digital Tapchanger Control provides the first customer protection functions. Use of a back-up relay, such as the M-0329B, is recommended since the M-2001C (BASE-R) (or any independent control) cannot be expected to be its own backup. The back-up relay bandcenter setting is usually set the same as the primary control, with the bandwidth setting 1 or 2 volts greater than the primary control bandwidth, the block raise setting 1 volt greater than the primary control, and the deadband setting 1 or 2 volts. These settings create a runback level 1 or 2 volts above the runback level of the primary control.

If primary control operation is desired first, the block raise setting and the resulting runback level of the backup relay must be higher than those of the primary control and the block lower setpoint must be lower than the primary control setting.

### Tap Position Block

Since Keep-Track is the sole method of tap position knowledge on the M-2001C (BASE-R), Tap Block Raise and Tap Block Lower are fixed at +16 and –16, respectively.

The Tap Position Block is disabled by setting the Tap Information screen to the Disable condition. Refer to the Appendix, Figure A-5. If the Tap Information screen is not disabled, the Tap Position block can be disabled by setting the Tap Limits screen to Disable.

### Overcurrent Block Operation

▲ **CAUTION:** The current input to the control is rated at 0.2 A continuous, 0.4 A for two hours, and 4.0 A for 1 second.

Refer to the Appendix, Figure A-4 for the Line Limit I screen of the Setpoint Menu. The Line Limit Current setpoint is available to block operation whenever the current exceeds the setting. Depending on the current scaling choice made in the **Configure** menu, the setting is adjustable from 0.2 to 0.64 amps in 0.01 amp increments, when using a 200 mA CT scale. If “Curr Transformer” is set for 1 A, the setting is adjustable from 1.0 to 3.2 Amps, and if the “Curr Transformer” is set for 5 A, the setting is adjustable from 5.0 to 16.0 Amps.

This feature can be used to protect the tapchanger switch during periods of excessive current. This feature can be effectively disabled by setting the blocking current to 0.64 amps, 3.2 Amps or 16-0 amps, depending on scaling CT choice.

---

## 3.5 Pulsed Output

---

When the output selection is “Pulsed”, the pulse width can be programmed from 0.2 to 12 seconds, in increments of 0.1 seconds.

When the output is set to "Pulsed" and the control is calling for Raise/Lower, an output will turn on for the preprogrammed time, or until a counter contact operates, and then turn off the output for a time period of 0.5 seconds plus the intertap time delay setting value. When the control is calling for a Raise/Lower and no counter input is applied, the output will activate for the full preprogrammed time and deactivate for 0.5 seconds, plus the intertap time delay.

When enabling the pulse feature on an LTC without a counter contact, to prevent hunting, care must be taken to set the ON pulse width less than the time it takes for a complete tap change to occur, but long enough for the seal-in circuit to be activated. The Intertap Time Delay should be longer than the time it takes for a complete tapchange to occur.

When a counter input is applied, and there is an intertap delay, the pulse will cease immediately (triac is turned off) with counter contact closure for the intertap time delay. After the counter contact opens, the intertap timer will start at the end of the time delay. If there is still a Raise/Lower condition, another pulse will start.

## 3.6 Application Considerations

### Sequential

The control operates in Sequential Mode. In this mode, the tap change output is initiated after the time delay timer has timed out. The tap change output will remain “on” until the control senses that the voltage has returned in-band. This permits successive tap changes to be made in a “sequential” mode with no delay between tap changes.

If a delay between successive tap changes is desired, an intertap time delay may be used. This value is set at the Intertap Delay screen in the Configuration Menu. The value is set from 0 to 60 seconds and will interrupt tap change outputs for the preset time after a counter-contact closure is detected by the control's operations counter input #1.

### Intertap Time Delay

The intertap time delay may be used in conjunction with sequential operation or pulsed output. The normal operation of this delay timer is as follows: once a tapchange command is initiated, when there would normally be a continuous command (raise or lower) to run the tapchanger until the voltage has returned to within the band setting, there is now an intertap time delay initiated between tapchanges. When the intertap time delay is set to zero, it is disabled.

When invoked by a user who possesses Level 2 security access (or above), the intertap time delay will:

1. Recognize that a tapchange has occurred, indicated by the counter contact input.
2. Remove the output signal and wait for the intertap time delay, even though the voltage remains outside the designated voltage band.

3. Command another tapchange after the intertap time delay has expired, without regard to the basic time delay setting, if the voltage remains out of band in the same direction as the previous tapchange.

■ **NOTE:** The intertap time delay applies a short delay after every tapchange, for the user-selected time delay (0 to 60 seconds). It is enabled via a menu screen. For application with pulsed output, see Section 3.5, **Pulsed Output**.

### Test Mode/Status Screen

This convenient screen permits entering a bias voltage for simulating the raising or lowering of the sensed input voltage. This exercises the control as if the input voltage were being changed. The contacts actually operate.

This screen is valuable in the rapid determination of operating quantities present to influence the normal operation of the control. Items that will block operations or change setpoints are described here and illustrated by LEDs on the face of the control.

The Test Mode/Status screen displays control status information that includes:

- Output Status
- Compensated Voltage
- Band Status
- Runback/Blocking Status
- Voltage Reduction Status

This screen automatically resets on exit or in 15 minutes if not exited. Refer to Appendix A, Figures A-2 and A-3.

Function	Setpoint Range	Increment	Initial Setting
Inter tap Time Delay	0 to 60 Seconds	1 Second	0 Seconds

Table 3-3 Intertap Time Delay Setpoint Range



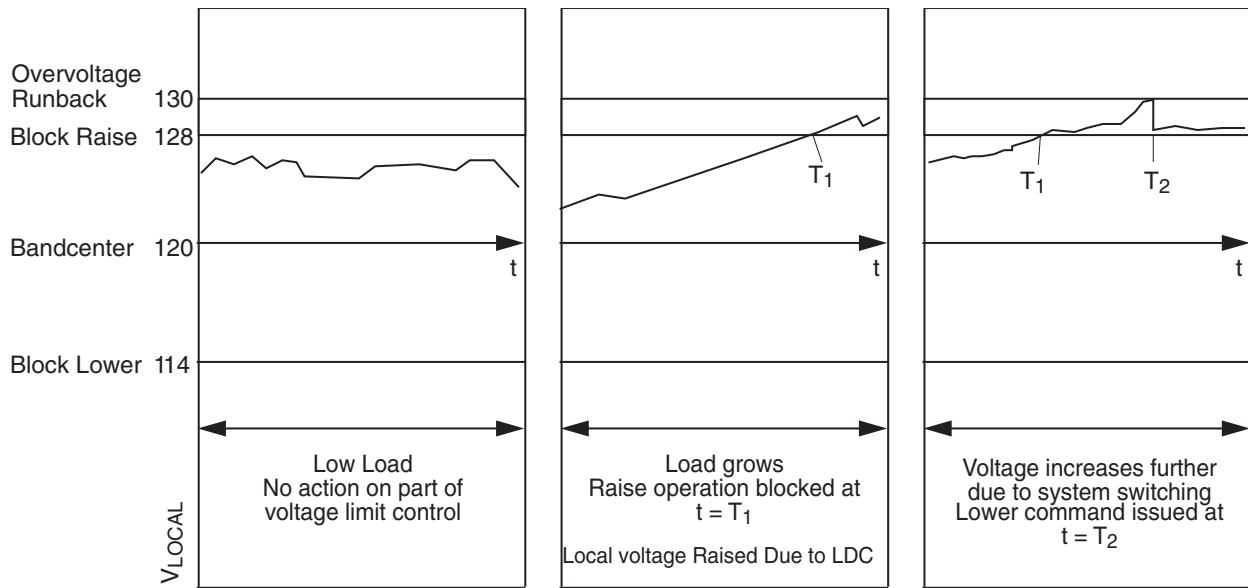

Figure 3-2 Local Voltage as Function of Load Current When Using Line Drop Compensation/ Action of Overvoltage and Overvoltage Runback Control

# 4 Configuration

4.0	Introduction .....	4-1
4.1	Passwords .....	4-1
4.2	User Identification .....	4-2
4.3	Counters .....	4-2
4.4	Correction Factors .....	4-3
4.5	Ratio Multipliers .....	4-4
4.6	Tap Information .....	4-4
4.7	Reverse Power Operation .....	4-6
4.8	Output Selection .....	4-7
4.9	Protocols/Communication .....	4-7
4.10	Basic Timer Types .....	4-7
4.11	Data Logging .....	4-7
4.12	Current Display/Scaling .....	4-8
4.13	Regulator Type .....	4-9

---

## 4.0 Introduction

---

This section describes the Configuration Menu of the software flow. Refer to Appendix A, Figures A-5 and A-8.

- **NOTE:** Panel display for configured items do not refresh. In order to reflect the change, user must scroll past the screens and then return.

---

## 4.1 Passwords

---

### Initializing Passwords (Control)

Refer to the Appendix, Figure A-5. The Level 1 and the communications passwords are set to all 0000 at the factory. The Level 2 password is set to 2222 at the factory and that password must initially be used to access the Configuration Menu. See Chapter 9, **M-2029A TapTalk®**, Utilities/Set New Passwords section.

New passwords may be entered from the screen within the Configuration Menu as described below. As soon as new passwords are entered, they will be required. Changing any setpoint or configuration will require the password, if enabled. *Enter passwords with care and record them for future use!*

▲ **CAUTION:** Please record all passwords in a secure location. If the password is lost or forgotten, please contact the factory.

### Configuring Passwords

The user who possesses the current Level 2 password may change any password using four new numbers. *A password is not required if the Level 2 password has been set to 0000.*

When **ENT** is pressed while viewing the password at its screen within the **Configuration** menu, an underline cursor is displayed under the digit furthest to the right of the password.

Each digit is changed by using the **↑** and **↓** pushbuttons to select the number. Use the **ENT** pushbutton to move the underline to the left. When the underline is on the far left digit, press **ENT** and the new password is stored into nonvolatile memory. If a wrong number has been entered, press **ENT** as many times as necessary and the underline will move to the digit furthest to the right for entry of the correct password. This should be done immediately to ensure that an incorrect password is not stored in memory.

If no key entry is made for approximately 15 minutes and the screen goes blank and the digit furthest to the left has not been entered, the password will revert to the previous one regardless of digits that have been changed. After a new Level 2 password has been entered, the new password must be used to reenter the **Configuration** menu. *Be sure to record the new password for future use.*

When a communication password has been configured at the control, the communication password allows the user to bypass both the configuration and setpoint passwords otherwise required by a control.

■ **NOTE:** The communication password is identified as a string #. Therefore, the passwords "0001" and "1" are not interchangeable.

Each control can be given a unique, 4-digit password ranging from 0 to 9999. If the password has been configured at the control as 0000, communication is not restricted a password does not need to be identified by M-2029A. The control is shipped with communication password disabled (set to 0000).

### Disabling Passwords

Any one of the three passwords can be disabled within the screens of the Configuration Menu by changing the password to zero (0000). When a password is disabled, its access screens will not be seen and the password will not be required.

### Configuration Changes

Use the **↑** and **↓** pushbuttons to display the To Configuration Menu prompt and press **ENT**. The Level 2 password is required for entry, unless disabled. Use the **↑**, **↓** and **ENT** pushbuttons to change the configuration.

---

## 4.2 User Identification

---

### Changing User Lines

Refer to the Appendix, Figure A-8. The user station identification lines allow the user to uniquely identify the unit. In normal operation, after 15 minutes without pressing a pushbutton on the display, the screen will be blank. If the screen is blank, any pushbutton press will reactivate it and display the User Lines screen. Each line of this display can have up to fifteen ASCII characters. Both of the lines are factory preset with asterisks.

When **ENT** is pressed at the User Line screen in the **Configuration** menu, an underline cursor is displayed under the left-most digit. Each digit is changed by using the **↑** and **↓** pushbuttons to select the ASCII character (the ASCII character list begins with "!"). The **ENT** pushbutton is used to move the underline to the next digit. When the **ENT** pushbutton is pressed for the right-hand digit, the new user line is stored into nonvolatile memory.

---

## 4.3 Counters

---

▲ **CAUTION:** When "Input Selection 1" configuration is set to "Seal-In," the Counter Input is used as the Switch Status Input and the Seal-In Input will cause the counter to increment.

The M-2001C (BASE-R) includes three configuration setpoints for the proper operation of the counter functions. These are necessary due to the different types of counter contacts on various equipment using these Digital Tapchanger (DTC) controls and the effect of wear on older counter operating mechanisms.

### Operations Counter

The user must select the method of counting tapchanger operations consistent with the tapchanger.

**X1** – Operation count will increment by one with an open-close-open state change on the tapchanger counter switch. The closed state may be present for as little as 20 ms. The open state may be present indefinitely.

**X2** – Operation count will increment by one with either an open-close or a close-open state change of the tapchanger operation counter switch. Both the closed and open states may exist indefinitely.

**Count Window** – Operation count will increment by only one count during a set time period or "Count Window". This is true no matter how many counter inputs occur during the count window time. After a counter input is accepted, the count window timer begins and another count won't be accepted until the count window time expires. The count window time can be set from 0.5 to 10.0 seconds, under the **Configuration** menu.

The counter accommodates 999,999 operation counts and the number of counts stored in memory is not affected by a loss of supply power. Total operation count is displayed in the Status Menu. This counter cannot be reset, but can be preset to any value up to 999,999 in the Configuration menu.

### Resettable Operations Counter

A second, resettable, operations counter operates with the method selected by X1/X2/Count Window. The user resets this counter to zero by pressing **ENT** while viewing the resettable operation counter screen within the Status Menu. No password is required to reset the resettable operations counter.

■ **NOTE:** The counter will only increment with a connection to the counter input.

---

## 4.4 Correction Factors

---

### VT Ratio Correction

Refer to the Appendix, Figure A-5. The operation of some regulators is such that the internal VT does not provide the desired voltage ratio. In these cases, it is desirable to correct the VT secondary voltage to a 120 V ac reference base. This change is easily made in software, eliminating the need for a multi-tap sensing transformer.

▲ **CAUTION:** The use of a voltage correction factor is incorporated in the calculation of primary quantities in the control, and erroneous values will be displayed and recorded if the VT correction factor is not included in the PT multiplier.

The correction is derived from information provided by the regulator original equipment manufacturer (OEM). The numerical value of the correction is the value, in volts, required to adjust the VT nominal secondary voltage to 120.0 volts. The correction range is  $\pm 15$  volts in 0.1 volt increments.

■ **NOTE:** The maximum allowable continuous VT secondary voltage is 140 volts. The correction is made only in software. As a result, the value of  $V_{LOCAL}$  read on the control display will differ from that measured at the voltmeter test terminals by the percent of the correction voltage.

### CT/VT Phase Shift

Refer to the Appendix, Figure A-5. The control will recognize forward and reverse power flow to the load. With the CT and VT (reference) signals in-phase for unity power flow to the load, it will properly calculate line drop compensation. Depending on the connection of the CT and VT, the phasors may not be in-phase. If this is the case, the phase shift can be corrected in software. The usual characteristics of three phase systems only allow multiples of  $30^\circ$  phase shifts. The control, therefore, has a range of  $0^\circ$  to  $330^\circ$  in  $30^\circ$  increments.

By comparing system operating conditions with power flow direction and power factor as shown on the M-2001C (BASE-R) Tapchanger Control, improper phase shift can be determined. An incorrect connection may be resolved using well-known phasor methods. The following procedure may be useful to check the choice of correction or even to determine the correction by trial and error:

1. Put the transformer or regulator on manual control.
2. Determine the Watts and VARs load on the transformer or regulator from other metering.
3. Read the Watts and VARs indicated by the control, and make certain that they are of the same sign and ratio of magnitudes as obtained from the external readings.
4. If not, change the correction in  $30^\circ$  increments until the control and external readings are in best agreement.

When two single-phase regulators are connected in open delta, the current signals will be out-of-phase with the voltage signals. For one regulator, the current will lead the voltage by 30° and is called the “leading” regulator. For the “lagging” regulator, the current will lag the voltage by 30°.

Contact Beckwith Electric for **Application Note #17** for more information on VT and CT connections.

---

## 4.5 Ratio Multipliers

---

### Voltage & Current Multipliers

▲ **CAUTION:** The use of a voltage correction factor is incorporated in the calculation of primary quantities in the control. Although the control operation is not affected, erroneous values will be displayed and recorded if the VT correction factor is not included in the PT multiplier.

Refer to the Appendix, Figure A-5. Primary quantities are displayed when voltage and current multipliers are set into the control. The voltage multiplier is:

$$V_{\text{mult}} = V_{\text{pri}} / (V_{\text{sec}} + V_{\text{corr}})$$

For a VT ratio of 7620/117 V and a voltage correction of 3 V, the multiplier is:

$$V_{\text{mult}} = 7620 / (117 + 3) = 63.5$$

The voltage multiplier setting range is from 0.1 to 3260 in 0.1 steps.

The current multiplier is the value of the line CT primary rating divided by 0.2 A. For a CT primary rating of 1000 A, the multiplier is:

$$CT_{\text{mult}} = 1000 / 0.2 = 5000$$

The current multiplier setting range is from 1 to 32600 in 1.0 steps.

Both multipliers are entered in the **Configuration** menu.

▲ **CAUTION:** The current input to the control is rated at 0.2 A continuous, 0.4 A for two hours, and 4.0 A for 1 second.

■ **NOTE:** The current transformer selection in the Configure menu only changes the scaling factor for current reading and setting.

---

## 4.6 Tap Information

---

The M-2001C (BASE-R) Digital Tapchanger Control tap position information applies to ±16 taps. The user is able to select the Keep Track or to disable this feature. Table 4-1 outlines the two selections available for the Tap Information screen.

### Tap Position by Keep Track (Reg Internal)

▲ **CAUTION:** This feature is applicable to single-phase regulators only.

▲ **CAUTION:** This feature is only applicable for ±16 tap ranges with neutral tap and neutral indicator. The source voltage will only be applicable with a tap range of ±16 taps.

This feature allows the control to keep track of the present tap position. The “Reg Internal” setting is selected for this method.

● **WARNING:** Do not rely on the tap position indication on the M-2001C (BASE-R) Tapchanger Control display for neutral position when bypassing voltage regulators.

The motor power source for the manual or automatic initiated tap changes must be the same as the motor power input to the control. The operations counter and neutral light circuit should be operational. The counter input and power source is required for detecting tap changes and determining direction of the tap change. Connecting a regulator neutral tap position indicating contact to the control will reset the tap position to neutral each time the tap goes through the neutral position. It is recommended that the indicated tap position be compared to the mechanical tap position indicator at regular intervals, and that the indicated value be corrected, if necessary.

The tap position stored in memory is not affected by a loss of power. The tap position record is checked and corrected to neutral, if necessary, with the closure of a neutral contact (when the neutral tap position contact is connected to the controls).

▲ **CAUTION:** When the keep-track tap position method is used, it must be calibrated for proper voltage control with reverse power operation.

If desired, the keep-track feature can be disabled in which case the screen will indicate “Disabled.”

The user initializes the control at a given, known, tap position upon installation, by selecting Reg Internal in the Tap Information screen in the Configuration Menu and performing the following steps:

1. Determine the actual tap position from the external tap position indicator on the regulator.
2. Scroll through the display to the Tap Calibrate screen in the **Configuration** menu. Press **ENT**. A flashing “C” indicates that the control is ready to accept data. Press the **▲** or **▼** pushbutton until the correct tap position is displayed. Press **ENT** again. The tap position is now calibrated to recognize all subsequent operations so as to “keep-track” of the present tap position.
3. The present tap position is indicated in the Status Menu at the Tap Position screen.

Or, if the neutral tap position contact is connected to the control, run the regulator to neutral as shown by the tap position indicator on the regulator. The control will recognize the neutral light signal and set the tap position accordingly.

The keep-track procedure recognizes tapchanges commanded via **manual or automatic** contacts. The power source for the manual-initiated tapchanges must be the same as the motor power source used for the automatic tapchangers.

The keep-track position knowledge is based on the detection of a closed switch (manual or automatic), and feedback from the operation counter input.

The method by which Keep Track is achieved is as follows:

The control includes two Zero Voltage Detection (ZVD) circuits. These circuits individually monitor the AC voltage across the internal raise and lower triacs. This is done since any external raise or lower contacts or manual switches have to be placed in parallel with the triacs to run the tapchanger motor. When the triacs (or any contact paralleled across the triacs) closes, the voltage measure decreases to almost zero. When a counter input event is received while the raise circuit is activated, the Keep Track will increment the tap count by one. When a counter input event is received while the lower circuit is activated, the Keep Track will decrement the tap count by one.

If the tapchanger reaches the mechanical tap limits of operation, ( $\pm 16$ ), limit switches open up the appropriate circuit so the control cannot force a raise above +16, or force a lower below -16. This is potentially confusing to the ZVD circuits, since they can see zero voltage on the output with a closed triac and also see zero voltage on the other output due to an open limit switch. When this condition is encountered, the control can only make a best guess of which operation really occurs and moves one step in the direction of neutral, which should be away from the side with the open limit switch.

An additional feature is the neutral zero feature. When a regulator passes through the neutral position, a neutral contact closes. This is most often used to drive a neutral light that is an indicator that the mechanism is in the neutral position, and it is safe to bridge the input and output of the regulator because they are at the same voltage. Upon detection of a neutral circuit closure, Keep track resets the tap position to neutral to resynchronize the circuit.

Screen Selections	Tap Position Knowledge Method	Current Range	Screens Disabled
REG INTERNAL	Keep Track	Not Applicable	None
DISABLE	None	None	Source Voltage, Tap Position

Table 4-1 Tap Information Screen Selections

## 4.7 Reverse Power Operation

### Detecting Reverse Power

Reverse power flow exists whenever the real component of the line current changes direction from forward and remains until another reversal to forward power occurs. The control reliably determines power direction with as little as 2% of the real component of the nominal 200 mA line current (4.0 mA).

### Power Direction Bias Configuration

The Power Direction Bias Configuration screen contains three settings to determine how the control will switch between forward and reverse power operation. The three settings are **No Bias**, **Forward Bias**, and **Reverse Bias**.

#### "No Bias" Setting

When the Power Direction Bias function is set to "No Bias", the control applies an 8 mA hysteresis band with a bandcenter of 0 load current (+4 mA to -4 mA) to switch between forward and reverse power. The control will switch from forward power to reverse power when the load current exceeds -4 mA (reverse direction). The control will switch from reverse power to forward power when the load current exceeds +4 mA (forward direction).

#### "Forward Bias" Setting

When the Power Direction Bias function is set to "Forward Bias", the control applies a 0 mA to -4 mA hysteresis band to switch between forward and reverse power. The control will switch from reverse power to forward power when load current is  $\geq 0$  mA (forward direction). The control will switch from forward power to reverse power when the load current exceeds -4 mA (reverse direction).

#### "Reverse Bias" Setting

When the Power Direction Bias function is set to "Reverse Bias", the control applies a 0 mA to +4 mA hysteresis band to switch between forward and reverse power. The control will switch from forward power to reverse power when load current is  $\leq 0$  mA (reverse direction). The control will switch from reverse power to forward power when the load current exceeds +4 mA (forward direction).

Upon detection of power reversal, after a 5 second delay, the control will operate in the selected mode. The operating mode is selected from the following options:

**Ignore** – The control will take no different action than in the forward direction. It essentially does not use the power direction in the control decisions.

This is the same as a control which does not have power direction knowledge.

This mode is intended for use on distribution systems which have the possibility of power reversal because of distributed generation (DG) on the feeders. In these applications, the DG usually does not have the capacity to control the voltage with the more powerful system intact.

The condition required for DG to control the voltage is the generation and transmission of large amounts of VARs through the line impedance back towards the system source. Usually two items prohibit this action: 1) the ability of the DG to generate those amounts of VARs and 2) the contractual obligations enforced by many utilities that the DG only affect KWs on the system.

**Block** – Inhibits automatic tapchange operation. This locks the tapchanger on the tap position in use at the time reverse power flow is detected. It is the recommended setting for independent power producers or in situations when reverse power flow is not expected. The control will revert to normal operation when forward power flow resumes.

**Regulate REV** (single-phase regulators only) – The control will detect reverse power flow and regulate according to reverse power settings as selected in the Setpoint Menu. With tap position knowledge, the control calculates the source-side potential without the use of a source side VT. This feature is designed for use with feeder voltage regulators which continue to operate in a radial mode after system switching causes the power flow reversal.

The source voltage is calculated by knowing the local voltage, the load current, and the tap position using a presumed regulator impedance. That impedance is a function of the tap position. The calculated source voltage is only valid with a 5/8% step-voltage regulator.

With the control recognizing reverse power flow, the following occurs:

- The **REV PWR** LED is illuminated.
- Reverse power setpoints are used.
- Source voltage is calculated and motor output commands are reversed. For example, when the voltage is high, the control raises the tap thereby lowering the voltage and a lower is indicated on the front panel LEDs.

**Return to Neutral** – To use this feature, a counter input must be provided, and one of the tap information modes must be enabled.

The Return to Neutral feature will cause the tap position to be driven to neutral when reverse power is detected. Tap position will be driven to neutral regardless of the voltage or currents present at the control. Once neutral is reached, the tap position will remain unchanged as long as reverse power is present. Normal operation will resume when forward power is detected.

This mode is intended as a safe response to a power reversal on a system which can have conflicting situations. As described earlier, a radially operating system with reverse power should be set to "Regulate Rev." However, if a DG causes a power reversal, the proper setting is usually "Ignore." In an application where both conditions are possible, and it is not possible for the control to determine the cause of power reversal, the proper setting of "Return to Neutral" is advised.

---

## 4.8 Output Selection

---

### Output Selection

There are two setup screens associated with this feature. This screen is located in the **Configuration** menu. A selection of continuous or pulse may be chosen.

### Output Pulse

Located in the Setpoint menu. The output pulse can be programmed from 0.2 to 12 seconds, in increments of 0.1 seconds. An initiated pulse will continue until the pulse time has been reached or a counter contact operates.

■ **NOTE:** When enabling the pulse feature on an LTC without a counter contact, care must be taken to make the ON pulse width less than the time it takes for a complete tap change to occur, but long enough for the seal-in circuit to be activated. The Intertap Time Delay should be longer than the time it takes for a complete tapchange to occur.

### Continuous

The output is continuous until the voltage returns into the bandwidth.

---

## 4.9 Protocols/Communication

---

The front communications port, COM2, uses BECO 2200 exclusively.

---

## 4.10 Basic Timer Types

---

The time delay of the control may be selected from two different types. Selection of an *Integrating* timer type increments the timer when the voltage is outside the band, and decrements the timer towards zero when the voltage is within the band. Selection of *Instantaneous* timer type increments the timer when the voltage is outside the band, and resets to zero instantly when the voltage returns within the band.

---

## 4.11 Data Logging

---

This feature allows you to configure the parameters that the control will use to log data (with M-2029A software) to an Excel or Lotus123 compatible spreadsheet file. Once the log parameters are uploaded through M-2029A, the control will log data to on-board memory. Logging will continue indefinitely until a new set of log parameters are uploaded, at which point all previously logged data will be lost. It is necessary that the log parameters are set up, and logging be initiated, through the Data Logger for this feature to work as expected.

There are 19 communication points associated with the data logging on the control. Data logging may be set/read from the BECO 2200 protocol.

There are four command points:

**Log Sample Period** – This is a read/write point. Data range is 1–9,999 minutes in increments of one minute.

**Full Record Flag** – This is a read only point. It reads zero if the memory has not yet been written over. Reads one if the data has wrapped around, and overwritten previous data.

**Log Point Select** – This is a read/write point. Data is set in binary format.

**Log Status** – This point is a command/status/read/write point. Command/status is as follows:

- 0 Not logging (command)  
*When a zero is written to this point, logging will stop.*
- 1 Logging (status)  
*If log status reads 1, logging is in progress.*



### 3 Start Logging (command)

When a three is written to log status, logging will start. Points 9-00 and 9-02 must be set up prior to issuance of a logging command. Logging will continue indefinitely, or until a stop logging command (0) is issued, in a circular buffer manner. The absolute size of the data logging array is 311,040 bytes. The start address of this buffer is 90000 hex. Data will always be logged in records. If the last record exceeds this number (311,040), then the first record at address 90000 hex will be overwritten.

### 4 Download (command)

When a four is written to log status:

- The oldest record time stamp can be read in BECO 2200 9-04, 9-05, 0-06.
- The newest record time stamp can be read in BECO 2200 9-07, 9-08, 9-09.
- The current logged data pointer can be read from BECO 2200 9-10, 9-11.
- The ready to download logged data pointer can be written in 9-12, 9-13.
- The first parameter of a record (a 16 bit word of information pointed by 9-12 and 9-13), along with the next 14 words will be ready for query with BECO 2200 protocol. You must issue a read of 15 points (only), starting with point number 9-14. Be aware that this scheme will not read records. It will read 15 words at a time, crossing record boundaries. It will start by reading the 1st parameter in a record, then it will read the next 15 words. As this happens, the control will set up the next 15 words to be read, starting with point 9-14, by incrementing the ready-to-download logged data pointer accordingly.

---

## 4.12 Current Display/Scaling

---

The current input rating of the M-2001C (BASE-R) Tapchanger Control is 200 mA, continuous. Auxiliary CT's are necessary if primary currents exceed this value.

The Current Transformer scaling selection is set in the Configure menu to be 200 mA, 1 A or 5 A. This choice fixes the scale of both the metering readout quantities and the settings of current values.

The status screen showing this information, **CONTROL LOAD I**, will be updated accordingly

**● WARNING: This selection is for scaling purposes only, and neither 1 A nor 5 A should be input to the control.**

The values of the current displayed in the control load I, and on circulating current screens can be displayed in either 200 mA, 1 A or 5 A scale.

**▲ CAUTION:** The current input to the control is rated at 0.2 A continuous, 0.4 A for two hours, and 4.0 A for 1 second.

The Line Limit Current setpoint screen is also affected by this selection.

### 4.13 Regulator Type

Regulator Type A or B can be selected in the **Configuration** menu. This will allow the source voltage to be calculated correctly for either type of regulator (see Figure 4-1). It will also allow the control to operate more accurately when in the "regulate in reverse power" mode.

General Electric VR-1 voltage regulators are available in two winding configurations; Type "A" non-inverted configuration and type "B" inverted configuration. These types refer to the internal power component connections. See figure 4-1.

The Type "A" non-inverted configuration regulator has a wire jumper on the NN terminal block for Potential Transformer tap selection.

On the older regulator controls (those not having power disconnect and CT shorting knife switches), the PT tap selection jumper is usually connected between terminals NN-9 and NN-20, NN-21 or NN-22. On newer regulator controls, (those with power disconnect and CT shorting knife switches), the PT tap selection jumper is usually connected between terminals NN-8 and NN-20, NN-21 or NN-22. There are special cases when a PT ratio correcting transformer is supplied and the jumper position is different. **In all cases please consult the regulator tank nameplate for the proper jumper connections.**

The Type "B" inverted configuration regulator is supplied from the factory with a standard 0.75 ohm resistor installed on the NN terminal block in addition to the PT tap selection jumper. This series resistor limits short circuit currents in the event of an external fault.

On the older regulator controls (those not having a power disconnect and CT shorting knife switches), the resistor is usually connected between terminals NN-9 and NN-22. The PT tap selection jumper is usually connected between terminals NN-22 and NN-20 or NN-21. On newer regulator controls, (those with power disconnect and CT shorting knife switches) the resistor is usually connected between terminals NN-8 and NN-22. The PT tap selection jumper is usually connected between terminals NN-22 and NN-20 or NN-21. **In all cases please consult the regulator tank nameplate for the proper jumper connections.**

The control can be damaged if the PT tap selection jumper is not connected properly when the regulator is energized.

The control is not powered if either the PT tap selection jumper or resistor is missing or open.

The customer should always verify proper connections by **consulting the nameplate on the regulator tank**. The customer is cautioned that the nameplate on the control cabinet could possibly be incorrect if the control has ever been replaced. If the serial number on the control cabinet matches the serial number on the regulator tank or nameplate, the control cabinet nameplate may be consulted for proper jumper configuration.

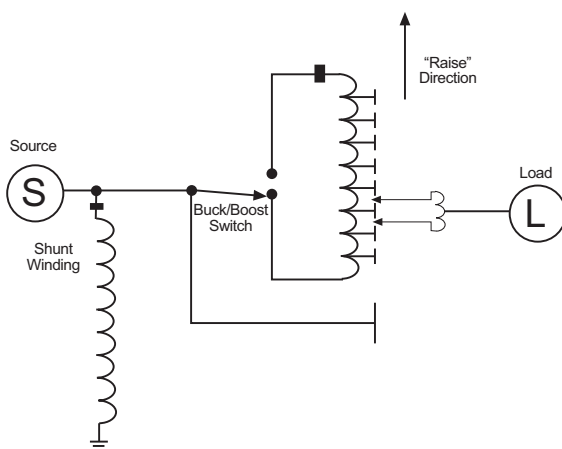

Schematic Diagram;  
Single-Phase, Type A Step-voltage  
Regulator

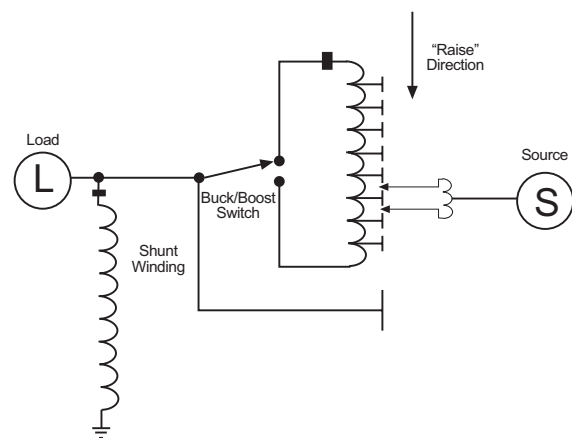

Schematic Diagram;  
Single-Phase, Type B Step-voltage  
Regulator

Figure 4-1 Regulator Type

**This Page Left Intentionally Blank**

# 5 Status

5.0	Introduction .....	5-1
5.1	Metering .....	5-1
5.2	Drag-Hand Display Quantities .....	5-3
5.3	Real Time Clock .....	5-3
5.4	Line Frequency .....	5-3
5.5	Voltage Reduction Status .....	5-4
5.6	Removal of Select Status Screens .....	5-4

---

## 5.0 Introduction

---

Refer to Figures 5-1 and 5-2.

The control has the capability of displaying measured and calculated secondary quantities and calculated primary quantities.

---

## 5.1 Metering

---

### Secondary

The display will show local voltage, source voltage, compensated voltage, line frequency, and load current in secondary quantities along with load power factor. The voltage is displayed on a 120 V base and the current is displayed on a 200 mA base.

■ **NOTE:** The local voltage displayed will not match the voltage measured at the test terminals on the adapter panel if a sensing VT ratio correction other than 0.0 V has been entered.

### Primary

Refer to the Appendix, Figure A-5. In order to use the calculated primary quantities feature, the user must enter the following data in the Configuration Menu:

1. Select line-to-line or line-to-ground VT configuration.
2. Select single-phase quantities based on measured inputs, or three-phase quantities based on measured inputs and assume a balanced system.
3. Select primary voltage and current multipliers needed to calculate primary quantities.

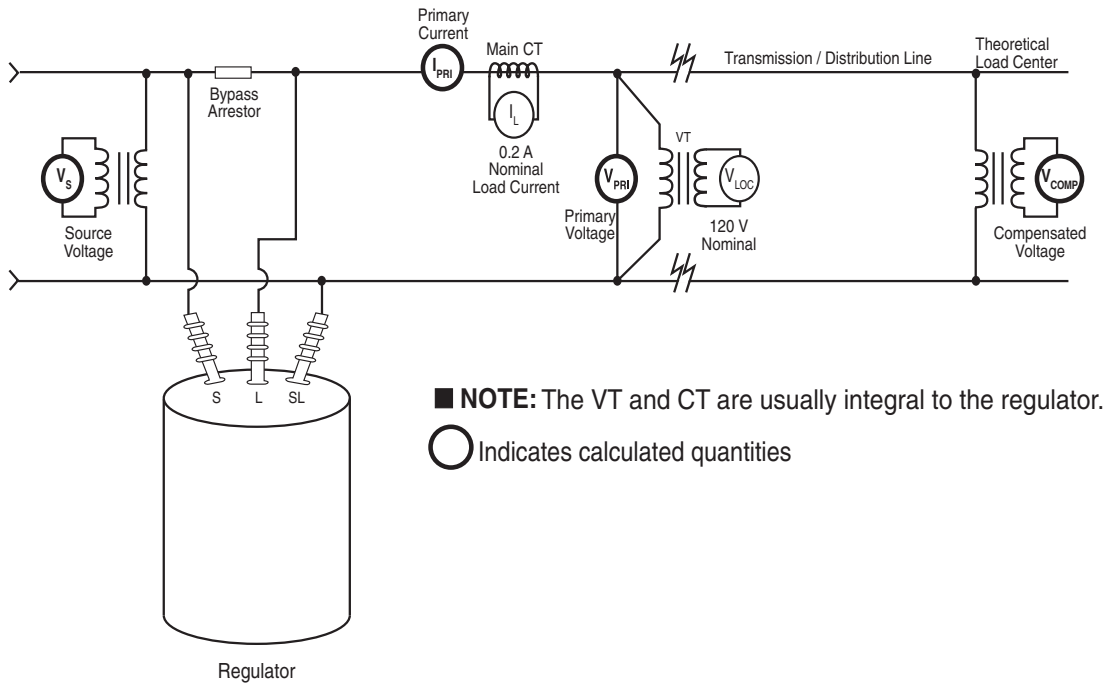

Figure 5-1 Secondary Quantity Metering and Primary Quantity Calculations for Regulator Applications

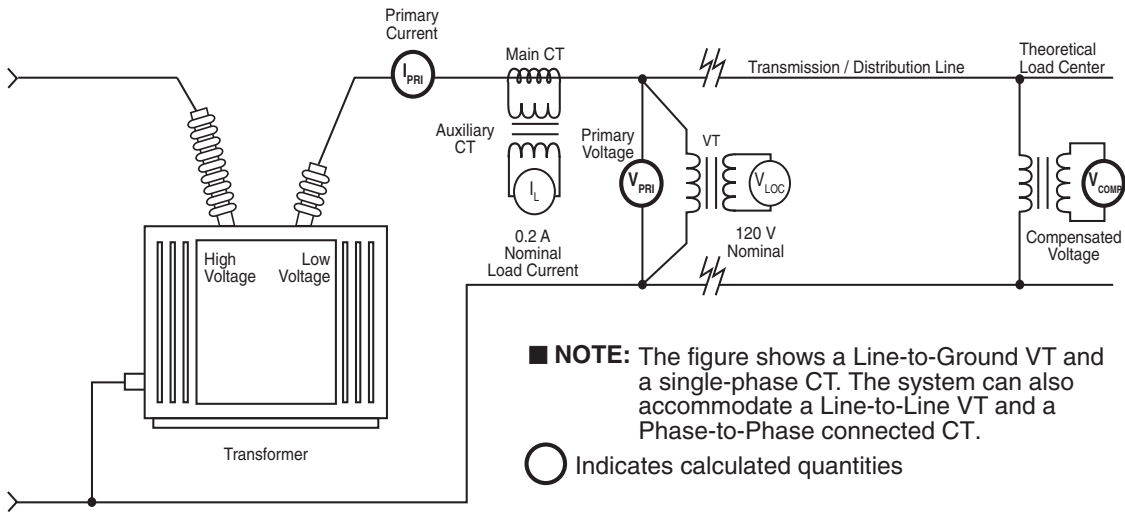

Figure 5-2 Secondary Quantity Metering and Primary Quantity Calculations for Transformer Applications

### Demand Metering

Refer to the Appendix, Figure A-5. The demand metering capability provided in the control follows the concept of a lagged demand meter. The demand time interval is selected by the user as 15, 30 or 60 minutes. This is the time it takes for a thermal meter to indicate 90% of a change in load.

### Quantitative Metering

Refer to Appendix A, Figure A-2. The quantitative metering function of the control displays the following measured values on the individual status screens:

- Total Reverse VAR Hours (KVARHR, MVARHR or GVARHR)
- Total Forward VAR Hours (KVARHR, MVARHR or GVARHR)
- Total Reverse Watt Hours (KWHR, MWHR or GWHR)
- Total Forward Watt Hours (KWHR, MWHR or GWHR)

The measured values are retained in non-volatile memory. A real time clock is utilized to record a date/time stamp for each quantity to indicate when the period of measurement was initiated.

When a quantitative metering screen is selected, three screens cycle continuously to indicate the total value, date and time the measurement was initiated. The **E** indicates that the measured value can be reset by pushing **ENT**.

---

## 5.2 Drag-Hand Display Quantities

---

Refer to the Appendix, Figure A-5. Drag-hand quantities are the maximum and minimum values for the period since the last reset command. These are retained in non-volatile memory. A real-time clock allows the recording of a date/time stamp with each drag-hand quantity. The following are available for drag-hand use:

- Min/Max tap position (when Tap Position is enabled)
- Min local voltage (120 V base)
- Max local voltage (120 V base)
- Max load current
- Max watts, kW or MW
- Max VAR, kVAR or MVAR
- Max VA, kVA or MVA
- Power Factor at max VA

Where primary quantities are used, values displayed are single-phase or three-phase as defined in the Pri Pwr Display Screen of the Configuration Menu.

▲ **CAUTION:** When the M-2001C (BASE-R) Tapchanger Control is used with a Beckwith Electric adapter panel, the panel's drag hands reset button only resets the mechanical drag hands of the regulator or LTC transformer. The button does **not** reset the tap draghands information stored in the control. The maximum and minimum tap position of the control should always be reset when the mechanical drag hands are reset.

The values retained in memory are time-tagged quantities that are calculated using the demand period selected (15, 30 or 60 minutes). For voltage, values are the average of samples taken over a period of 32 seconds which avoids undue retention of momentary voltage transients. The load power factor retained is the value at the time of max VA.

When selected, three screens for each parameter cycle continuously and indicate the value, date and time of each parameter. The **E** indicates that the drag-hand can be reset by pushing **ENT**.

---

## 5.3 Real-Time Clock

---

Refer to the Appendix, Figure A-2. The control is equipped with a real-time, 24-hour clock which is used with the drag-hand feature to record date/time stamp information on quantities saved in memory. The power source for the clock is maintained for at least 24 hours during a system power outage by a charged capacitor (no battery). If the power outage lasts longer than 24 hours, check the clock and reset if necessary.

---

## 5.4 Line Frequency

---

Refer to the Appendix, Figure A-2. The control provides for real-time metering of the line frequency. If the control is a 60 Hz model, the operating frequency is 55 to 65 Hz; if the control is a 50 Hz model, the operating frequency is 45 to 55 Hz.

---

## 5.5. Voltage Reduction Status

---

▲ **Caution:** Enabling this function may shorten the life of the screen.

Refer to Figure A-5. The control has a flashing voltage reduction status which can be enabled/disabled in the Flash V Red Mode screen of the **Configuration** menu. When enabled, and voltage reduction mode is active, the display will show the local voltage for approximately two seconds, then turn off for approximately 7 seconds. Then the voltage reduction status will be displayed for approximately two seconds, then turn off for about 7 seconds. Then the cycle will repeat, as long as voltage reduction mode is active and the front panel pushbuttons have not been used in the past five minutes.

---

## 5.6 Removal of Select Status Screens

---

Select status screens can be removed by pressing and holding the **ENT** pushbutton, and then also pressing the **↓** pushbutton. This will cause the present status screen to be removed from the status menu for quicker status access. Only the screens that do not use the **ENT** button in any way can be removed. The status screens that can be removed are: Comp. V, Source V, Circ I, Load I, Power Factor, Primary screens (V, I, VA, Watts, VARs), Total Op Count, Pf at Max VA, and Timers. All of the screens can be restored from the "Restore Status Screens" menu item in the **Configuration** menu.

# 6 Connections

6.0	Installation .....	6-1
6.1	External Connections .....	6-1
6.2	Multi-Step Voltage Reduction .....	6-5
6.3	Back-up Control .....	6-6
6.4	Communication Port .....	6-6
6.5	Grounding .....	6-6
6.6	Typical Regulator Connection .....	6-6

---

## 6.0 Installation

---

An adapter panel or a M-2050 or M-2054 Surface Mounting Kit must be used with the M-2001C (BASE-R) Tapchanger Control. Each panel adapts the control as a transformer or regulator control replacement and provides the external connections necessary for operation via terminal blocks on the rear of the adapter panel.

In lieu of using an adapter panel to mount the control, the M-2050 or M-2054 Surface Mounting Kit permits surface mounting. The kit consists of two right angle mounting brackets which bolt to the rear top and bottom of the control. All necessary hardware is included in the kit. Also included is a 24-pin, in-line female connector with six-foot pigtails on each pin to facilitate custom connection of the control in original equipment manufacturers' applications.

---

## 6.1 External Connections

---

Available connectors include one 24-pin Blue connector and one RS-232 DE9S connector. See Figure 2-1 for the locations of these external connectors.

The external connectors for the control are made to the 24-pin connection, P2. For example, if external dry contacts are being used to control the voltage reduction Step #1 function, connections for these contacts may be made between Pin 10 and Pin 18 as shown in Figure 6-1. The dry contact inputs for voltage reduction, motor seal-in, counter input, and neutral detection must be "wetted" by connection to Pin 10.



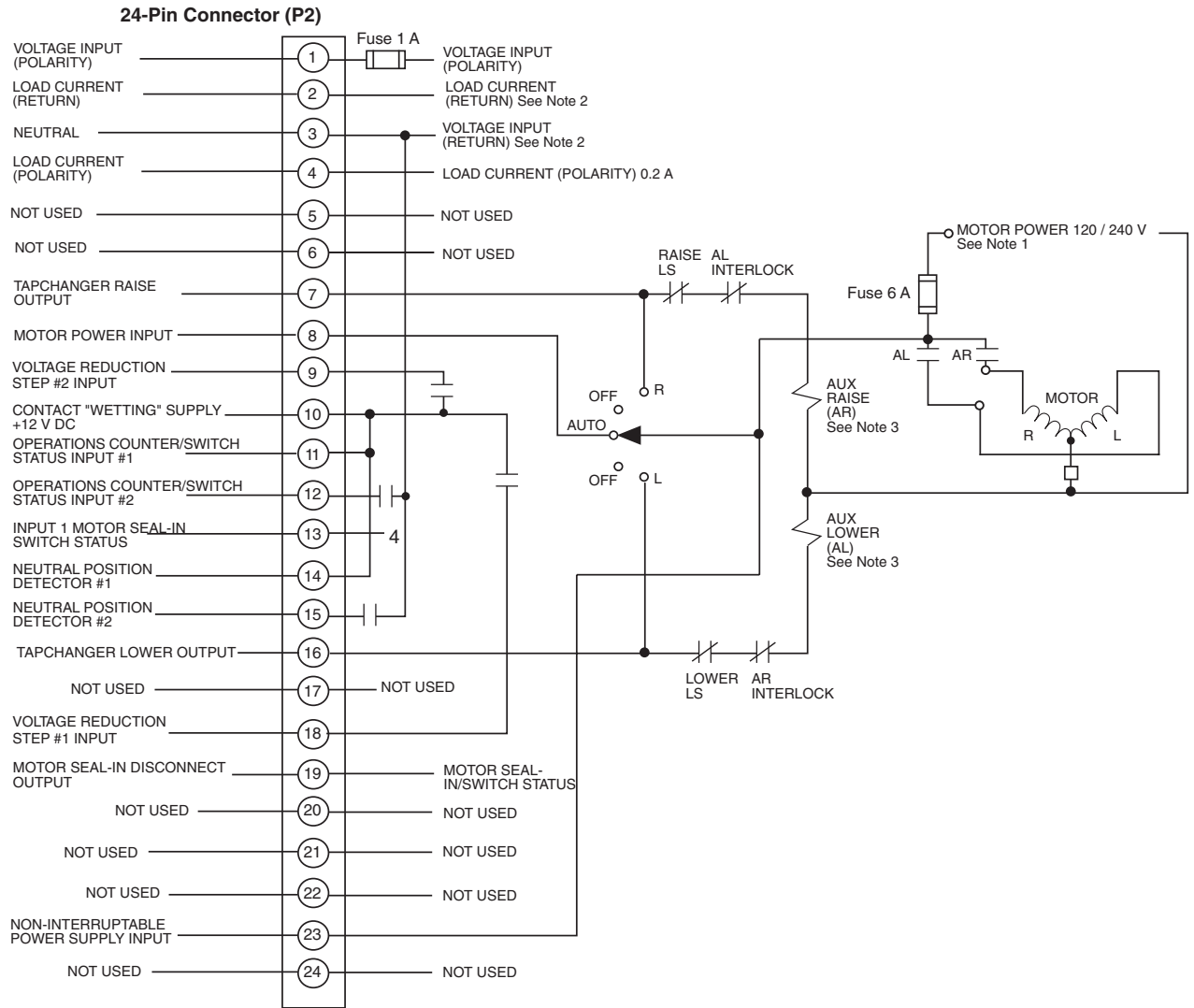

■ NOTES:

1. Motor voltage may be 120 or 240 V to neutral.
2. The customer is to provide an earth ground connection to the CT/VT's neutral connection, external to the control.
3. Due to leakage current through the output triac's protection circuitry, auxiliary relays with high impedance, coils may not drop out. For additional assistance, contact the factory.
4. To Motor Power Seal-In board.

● **WARNING:** When an adapter panel is not used, automatic shorting of CT input is not provided by the M-2001C/M-2050; the customer must provide a method for shorting the CT before the control is disconnected.

Figure 6-1 Typical M-2001C (BASE-R) Stand-Alone Connections

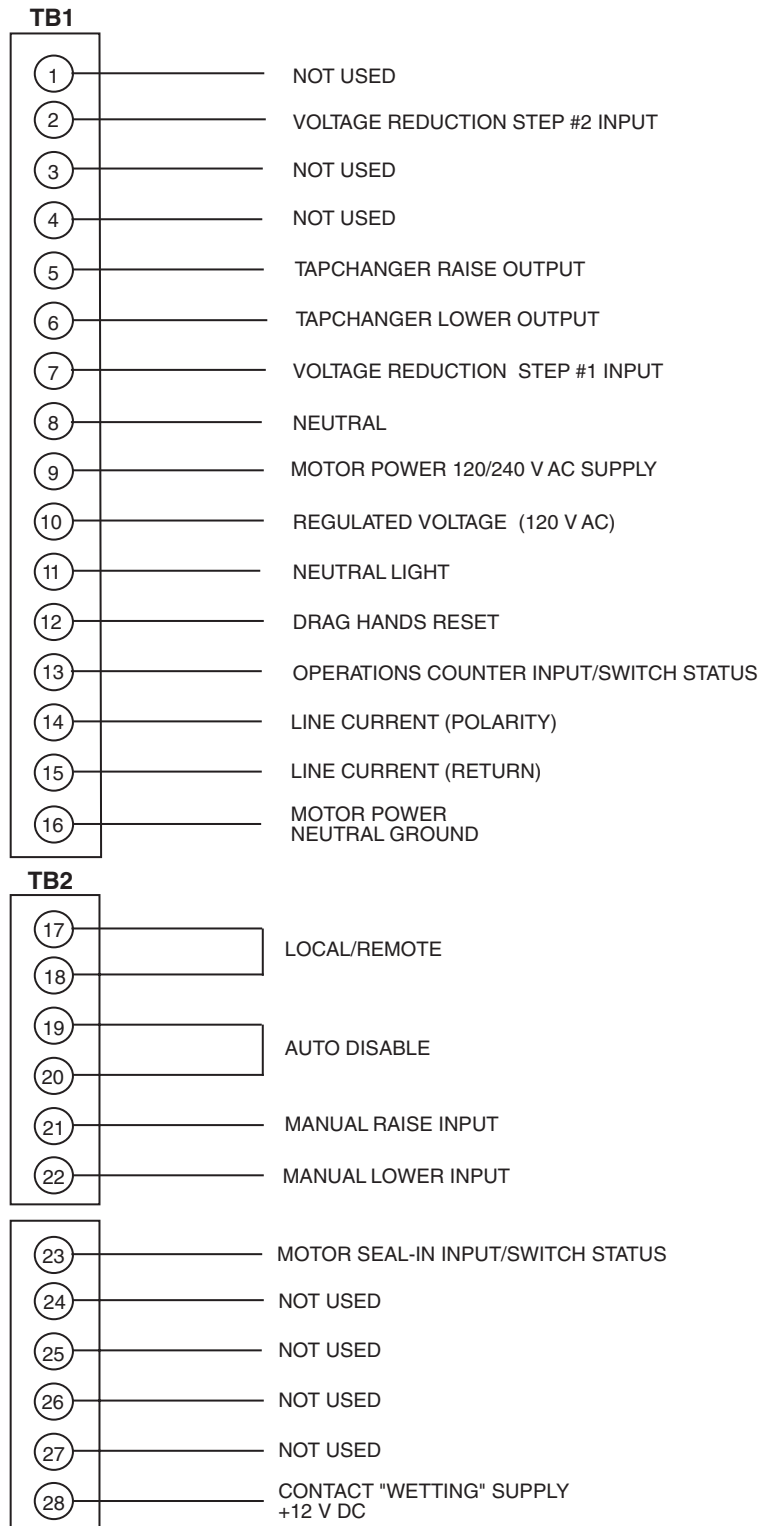

● **WARNING:** Open CT secondary will result in high voltage at CT terminals. Death, severe injury or damage to equipment can occur.

▲ **CAUTION:** Do not operate with CT secondary open. Short circuit or apply burden at CT secondary during operation.

Figure 6-2 External Connections

### M-2001C (BASE-R) Control (Blue Connector)

▲ **CAUTION:** These binary inputs must be "wetted" by connection to Pin 10 ONLY – a nominal 12 V dc source. If the contacts are connected to a 120 V ac source, it will result in damage to the control. External connections to the control are shown in Figure 6-1.

■ **NOTE:** The communication port provides remote access to the tapchanger control using the M-2029A TapTalk® Communications Software.

#### Pin 1 Voltage Input

This input accepts nominal 120 V ac, 60 Hz (or 50 Hz as ordered) to operate the control's power supply and voltage sensing input. The acceptable voltage range for proper control operation is from 90–140 V ac.

Power consumption is less than 8 VA. The input voltage is referenced to line neutral (Pin 3).

Control users may encounter situations where actuating the Drag Hands Reset pushbutton on one of any of our adapter panels results in the loss of Voltage Sense fuse. The Drag Hands reset solenoid is powered from the circuit that powers the control, and provides the control with sensing voltage. Initially, a 1/4 ampere fuse was used in this circuit, and most recently a 1 ampere fuse was substituted to prevent further loss of the fuse. This phenomenon is due to the fact that as solenoids age, they may become sticky due to mechanical misalignment, hardened grease, or shortened windings.

The adapter panels include a 1 ampere fuse in the voltage sense circuit. This value should be adequate for all but the most extreme problems. When a Drag Hands Reset Solenoid that consistently blows a 1 ampere fuse is encountered, it is recommended that the customer either remove the solenoid for cleaning and adjustment, or replace it completely.

#### Pin 2 Load Current Return

This is the non-polarity input to the load current measuring transformer. The companion polarity input is Pin 4. The line current transformer input is isolated from other pins.

#### Pin 3 Neutral

This is the return for the Voltage Input (Pin 1), and nominal +12 V dc "wetting" voltage (Pin 10).

#### Pin 4 Load Current Polarity

The line current input range is 0–640 mA (200 mA continuous) with 200 mA representing the 1.0 per-

unit value. The measured current value is used for line drop compensation and metering calculation.

▲ **CAUTION:** The current input to the M-2001C (BASE-R) is rated at 0.2 A continuous, 0.4 A for two hours, and 4.0 A for 1 second.

#### Pin 5 Not Used

#### Pin 6 Not Used

#### Pin 7 Tapchanger Raise

This switched output connects the tapchanger raise winding to the source of motor power. When the control calls for a raise, it is capable of switching up to 6 A at 120/240 V ac.

#### Pin 8 Motor Power Input

The source for powering the tapchanger motor is connected here. It may have a maximum voltage of 240 V ac.

#### Pin 9 Voltage Reduction Step #2

This digital input is typically enabled by connecting it to the nominal +12 Vdc wetting source (Pin 10), through an external Form "a" dry contact. The amount of voltage reduction implemented is determined by the setting.

#### Pin 10 +12 V dc Wetting Voltage

This is the output of an unregulated dc power supply internal to the control. It is referenced to neutral and can supply up to 100 mA. It is used for powering the digital inputs of the control through external relays. Depending on the voltage supplied to Pin 1 and loading, its output can vary from +10 to +18 V dc. It is not fused in the control.

#### Pins 11 & 12 Operations Counter Inputs 1 and 2

▲ **CAUTION:** When "Input Selection 1" configuration is set to "Seal-In," the Counter Input is used as the Switch Status Input and the Seal-In Input will cause the counter to increment.

This digital input registers the counter contact closure. The pins are isolated from neutral to permit placing the external contact in series with either the wetting voltage or neutral. The operation count will increment when Pin 12 is grounded via the transformer or regulator dry operation count switch.

This contact is needed for using the intertap time delay. Once the contact is opened, the intertap time delay will begin counting down.

**Pin 13 Input 1 - Motor Seal-In/Switch Status Input**

When the **Input Selection (1)** screen in the **Configuration** menu is set to **Seal-In Input**, this input will operate as a seal-in input and counter input. In this configuration, the digital input is referenced to line neutral, but is unique in that it is configured to accept only the output of the motor seal-in current detection transformer, from the B-0553 motor seal-in printed circuit board subassembly. The B-0553 is a supplemental circuit board used in the appropriate adapter panels.

When the **Input Selection (1)** screen in the **Configuration** menu is set to **Switch Status Input**, this input will only operate as a switch status input. All seal-in input functions will be disabled. In this mode, the switch status on the adapter panel can be read to determine if it is in Auto or Manual ON/OFF. The status can be read through the seal-in/switch status data point in the communications protocols.

**Pins 14 & 15 Neutral Position Detector Input**

This digital input registers neutral position switch closures on regulators. The pins are isolated from neutral to permit placement of the external contact in series with either the wetting voltage or neutral. Normally the wetting supply (Pin 10) will be connected to Pin 14.

**Pin 16 Tapchanger Lower Output**

This switched output connects the tapchanger lower winding to the source of motor power. When the control calls for a lower, it is capable of switching up to 6 A at 120/240 V ac.

**Pin 17 Not Used****Pin 18 Voltage Reduction Step #1**

This digital input is typically enabled by connecting it to the nominal +12 V dc wetting source (Pin 10) through an external Form “a” dry contact. The amount of voltage reduction implemented is determined by the setting.

- **NOTE:** Enabling both voltage reduction step #1 and step #2 inputs simultaneously will result in the level of voltage reduction as specified on the voltage reduction step #3 screen of the control.

**Pin 19 Motor Seal-In Disconnect Output**

This output connects to the B-0553 motor seal-in printed circuit board subassembly. When the seal-in detector input is actuated, this output drives a triac on the B-0553 motor seal-in printed circuit board subassembly to temporarily disconnect the motor power to the control. The B-0553 is a supplemental circuit board used in the appropriate adapter panels.

**Pins 20 & 22 Not Used****Pins 21 & 24 Not Used****Pin 23 Non-Interruptible Power Supply Input**

This input is normally connected to Pin 8, the motor power input. The power to Pin 8 is interrupted by the motor seal-in process of the B-0553 motor seal-in printed circuit board. The purpose of Pin 23 is to provide continuous power to the raise and lower keep-track detection circuits. It should be connected ahead of any motor power interruption (for example, auto/manual, local/remote) of the seal-in circuitry to maintain keep-track raise and lower operation.

---

## 6.2 Multi-Step Voltage Reduction

---

On the M-2001C (BASE-R) Tapchanger Control, Pin 9 and Pin 18 on connector P2 are used together to provide up to three levels of voltage reduction. The external connections to achieve these steps are shown in Table 6-1. Voltage reduction amounts are set within the M-2001C (BASE-R) Tapchanger Control software. If these voltage reduction steps are instituted by communications, the contacts are not being used simultaneously.

▲ **CAUTION:** Voltage applied through dry contacts to actuate voltage reduction inputs; counter contacts and neutral contacts *must* be nominal +12 V dc obtained from Pin 10 of the M-2001C (BASE-R) Tapchanger Control. The use of 120 V ac will result in damage to the control.

### 6.3 Backup Control

Although usually employed in LTC applications, the M-0329B LTC Backup Control can be useful in preventing excessive voltage excursions on regulators in applications where voltage control is critical.

The M-0329B is a single-phase, solid-state backup control that prevents a defective tapchanger control from running the voltage outside the upper and lower voltage limits. The Block Raise and Block Lower voltage levels are set by accurately calibrated dials. Refer to the M-0329B Instruction Book for details.

The M-0329B LTC Backup Control or M-5329 Multiphase Backup Relay are connected as two-terminal devices to the voltage transformer.

### 6.4 Communication Port

COM2 is an internal port, and supports only BECO 2200 protocol and software updates. COM2 supports baud rates from 1200 to 19200.

### 6.5 Grounding

Ground the control by connecting a suitably sized wire from the ground stud on the bottom of the control case, to a solid connection to ground. Do not rely on mounting screws for grounding.

### 6.6 Typical Regulator Connection

Figures 6-3 and 6-4 show examples of connections for a control with a transformer/regulator control adapter panel. Motor Power and sensing voltage can be obtained from a common source or from an independent source having a nominal 120 V ac output. Normally, this is line-to-neutral voltage, although line-to-line voltage can be used if recognition is made of any phase shift between the voltage and current signals when using line drop compensation.

**▲ CAUTION:** The current input to the M-2001C is rated at 0.2 A continuous, 0.4 A for two hours, and 4.0 A for one second.

Load current must be reduced by an appropriate auxiliary transformer to 0.2 A "full scale" before connecting to the adapter panel current inputs. Scaling factors may be chosen to resemble 200 mA, 100 mA, or 5 A current transformers in readouts and current magnitude settings. It is important that you obtain an application guide on an adapter panel specific to your regulator application and follow those instructions.

Voltage Reduction Setpoint: Multiplier Range	Apply "Wetting Voltage" from Pin 10 to Pin #
Voltage Reduction Setpoint #1: 0 to 10%	Pin 18
Voltage Reduction Setpoint #2: 0 to 10%	Pin 9
Voltage Reduction Setpoint #3: 0 to 10%	Pin 18 and 9

Table 6-1 Multi-Step Voltage Reduction External Connections

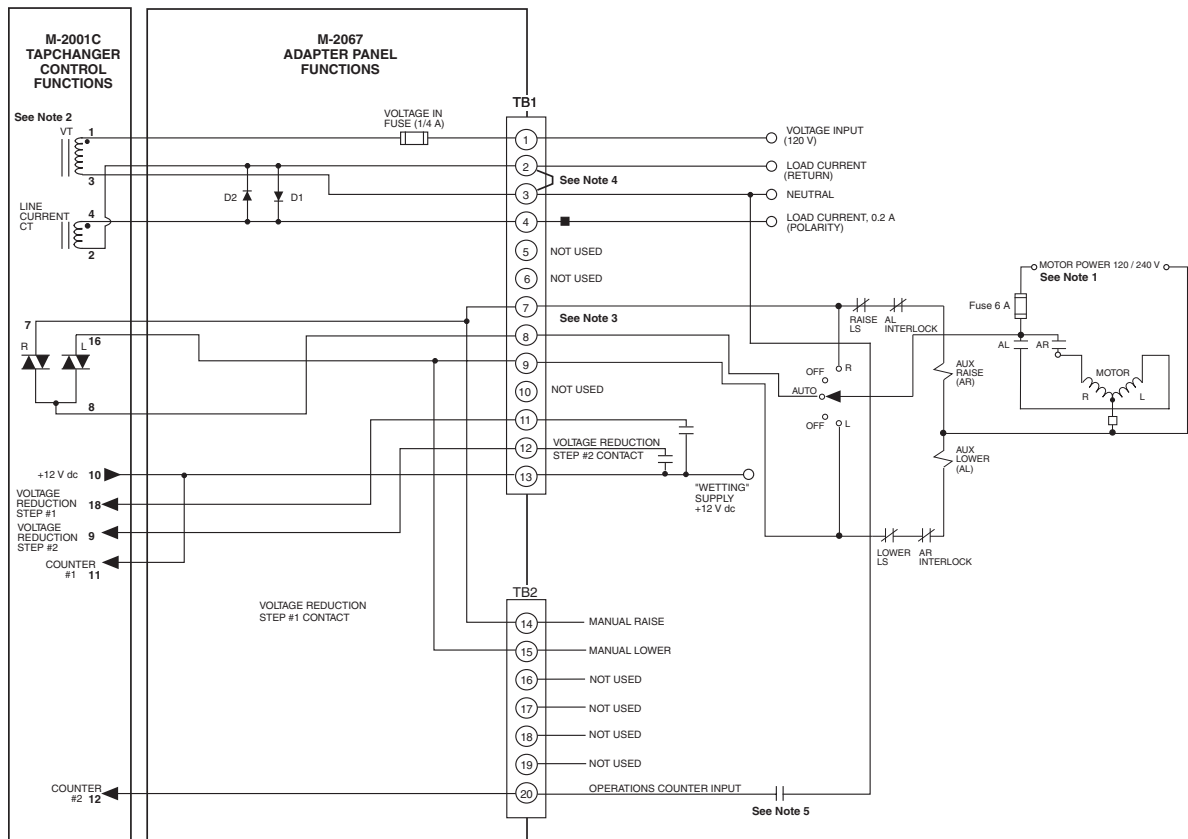

**WARNING:** In no case should the line current circuit be interrupted with the regulator or transformer energized. Do not remove auxiliary current transformers without shorting the current inputs. Death or severe electrical shock can occur.

**NOTES:**

1. Motor voltage may be 120 or 240 V to neutral or 240 V phase to phase.
2. The customer is to provide earth ground connection to CT/VT's neutral connection, external to the control.
3. The wiring from terminal 7 and 9 may or may not go directly to the motor. Depending on installation, local codes and standards, the wiring may go to interposing relay contacts, limit switch, seal-in circuits, starters contactors, SCADA, test switches etc.
4. To isolate the load current, remove the jumper from TB1-2 to TB1-3.
5. For counter operation, connect TB2-20 to neutral TB1-3 through an external dry contact. This connection is required for the intertap time delay operation.

Figure 6-3 M-2001C (BASE-R) and LTC Transformer Control Typical Connections

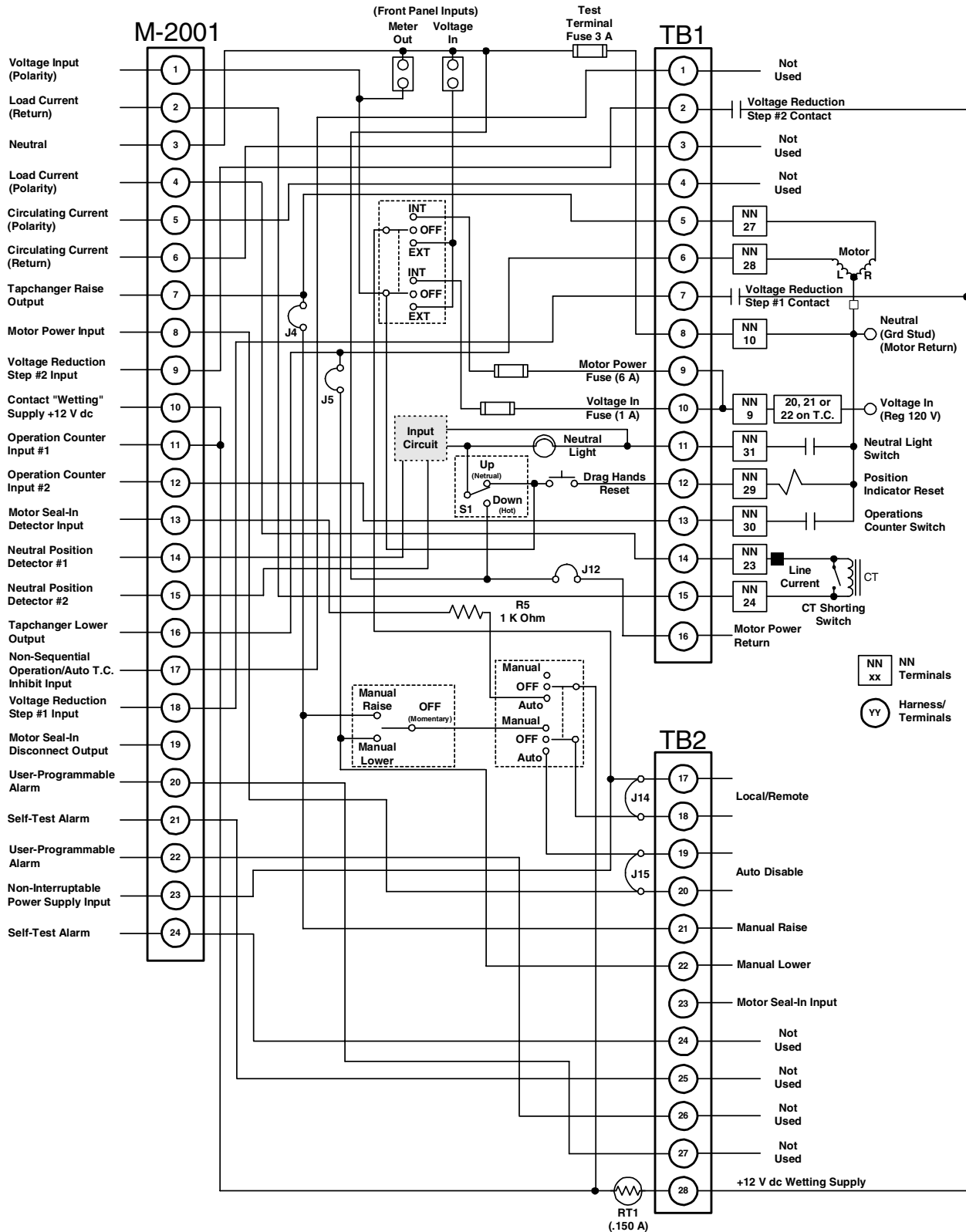

■ **NOTE:** The wiring from terminal 5 and 6 may or may not go directly to the motor. Depending on installation, local codes and standards, the wiring may go to interposing relay contacts, limit switch, seal-in circuits, starters contactors, SCADA, test switches etc.

Figure 6-4 M-2001C (BASE-R) and Regulator Control Typical Connections

# 7 Test Procedure

7.0 Set-up Procedure ..... 7-1  
 7.1 Bench-Test ..... 7-3  
 7.2 Check-out Procedure ..... 7-4  
 7.3 Operational Test ..... 7-5  
 7.4 In-Service Test ..... 7-5

This chapter assumes that the M-2001C (BASE-R) Tapchanger Control is **not** being used with an M-2050B Mounting Kit or an adapter panel (for example, when used by an original equipment manufacturer for use in a control panel). If the control is being used with an M-2050B Mounting Kit or an adapter panel, refer to the Test Procedures chapter of the corresponding Application Guide rather than this chapter.

## 7.0 Set-up Procedure

### Equipment List

▲ **CAUTION:** The current input to the M-2001C is rated at 0.2 A continuous, 0.4 A for two hours, and 4.0 A for 1 second.

- 0–200 mA current supply with phase angle settings of 0° to +90°
- 90–145 V ac voltage source at 60 Hz
- High impedance true RMS voltmeter with accuracy on ac of at least ±0.2% of reading
- Accurate stop watch

### Procedure

1. Make electrical connections as shown in Figure 7-1, External Connections for Test Procedure.

■ **NOTE:** Refer to the Appendix, Figures A-1 through A-13, for the locations of screens within the software.

■ **NOTE:** There is a one-second delay between the out-of-band condition and panel LED indication.

2. Enter initial settings:

Function	Initial Setting
Bandcenter	120.0 V
Bandwidth	2.0 V
LDC Resistance	0.0 V
LDC Reactance	0.0 V
Block Raise	135.0 V
Block Lower	105.0 V
Deadband	2.0 V
Time Delay	5.0 Seconds

Table 7-1 Initial Settings



GE-2011B

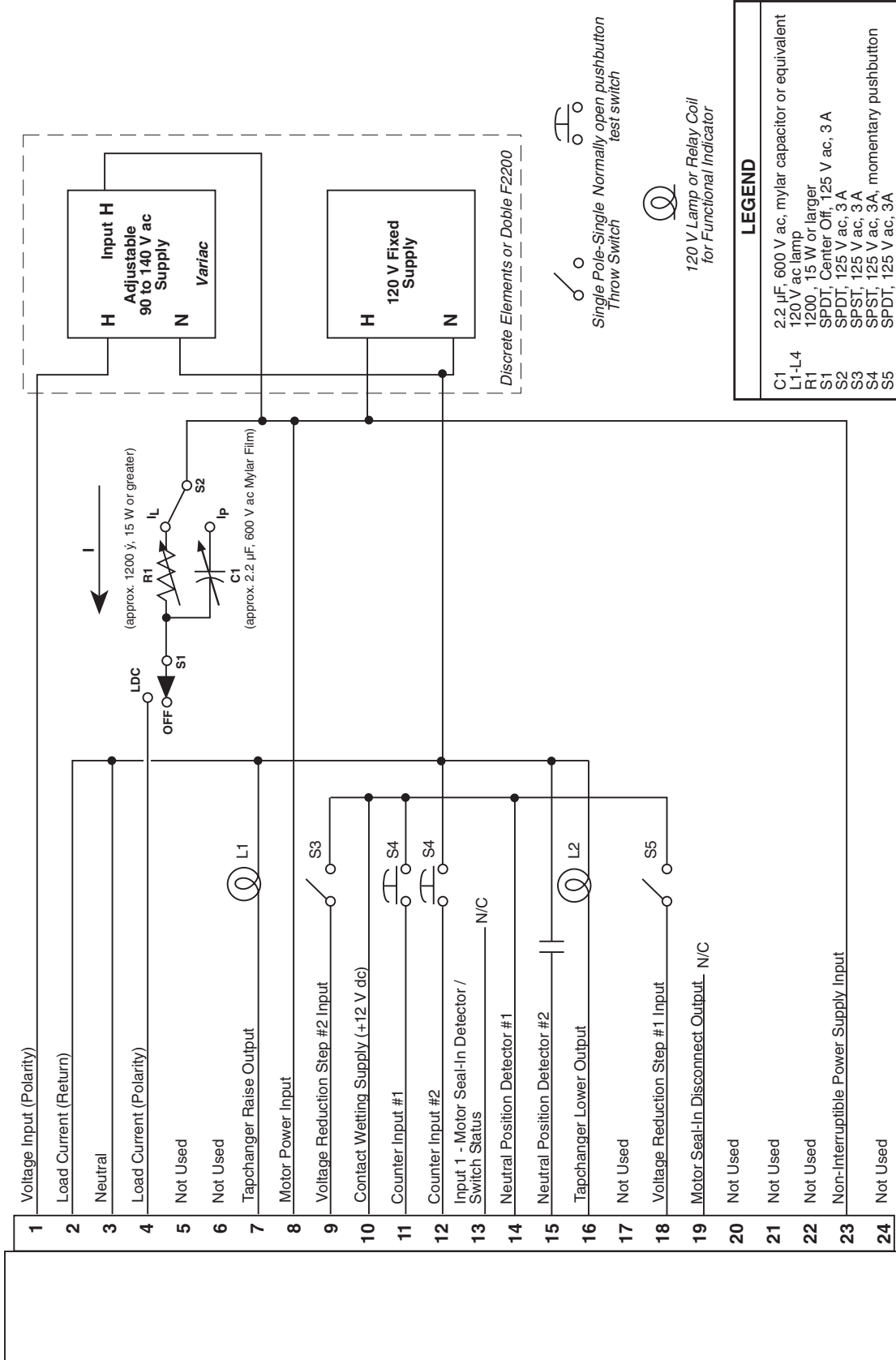

Figure 7-1 External Connections for Test Procedure

## 7.1 Bench Test

▲ **CAUTION:** Do not reverse the ground and hot wires when connecting an external source.

1. Apply 120 V ac from power source. The display of the M-2001C (BASE-R) will automatically advance to the Local Voltage screen.
2. Increase voltage to 121.2. The **LOWER** LED should illuminate.
3. Decrease voltage to 118.8. The **RAISE** LED should illuminate.
4. Set the input voltage to 120.0 V ac. Wait for **RAISE** and **LOWER** LEDs to extinguish.
5. Increase voltage to 122.0 V ac, then start timing when voltage passes 121.0 V.
6. Stop timing when the lamp connected to the **LOWER** output illuminates (should be approximately 5 seconds).

### Resistance

1. Apply a 100.0 mA in-phase current to Pin 4 (load current-polarity) and Pin 2 (load current-return) of the P2 connector.
2. Set  $S_1$  to LDC and  $S_2$  to  $I_L$ .
3. Set LDC Resistance to 24.0 V. The **RAISE** LED should illuminate.
4. Increase the input voltage to 132.0 V ac. The **RAISE** and **LOWER** LEDs should be extinguished.
5. Set the LDC Resistance to -24.0 V. The **LOWER** LED should light.
6. Decrease the input voltage to 108.0 V ac. Both **RAISE** and **LOWER** LEDs should extinguish.
7. Set the LDC Resistance to 0.0 V.
8. Decrease the input voltage to 120 V ac.

### Reactance

1. Apply 100.0 mA 90° leading current to Pin 4 (load current-polarity) and Pin 2 (load current-return) of the P2 connector.
2. Set  $S_1$  to LDC and  $S_2$  to  $I_L$ .
3. Set LDC Reactance to 24.0 V. The **LOWER** LED should illuminate.
4. Decrease the input voltage to 108.0 V ac. The **RAISE** and **LOWER** LEDs should be extinguished.
5. Set LDC Reactance to -24.0 V; the **RAISE** LED should illuminate.
6. Increase input voltage to 132.0 V ac. Both **RAISE** and **LOWER** LEDs should be extinguished.
7. Set the LDC Reactance to 0.0 V.
8. Decrease the input voltage to 120 V ac.

### Voltage Reduction

1. Set Voltage Reduction Step #1 to 2.5% (default setting).
2. Close  $S_5$  to enable Voltage Reduction Step #1. The **LOWER** LED should illuminate.
3. Decrease the voltage to 117.0 V ac. The **LOWER** LED should be extinguished.
4. Open  $S_5$  and decrease the input voltage to 120.0 V.
5. Set Voltage Reduction Step #2 to 5% (default setting).
6. Close  $S_3$  to enable Voltage Reduction step #2. The **LOWER** LED should illuminate.
7. Decrease voltage to 114.0 V ac. The **LOWER** LED should extinguish.
8. Open  $S_3$  and decrease the input voltage to 120.0 V ac.

### Counter

1. Set the M-2001C Tapchanger Control to display the Operations Count screen for the Total Operations Counter.
2. Verify counter operation by depressing  $S_4$  wired to Pin 11 and Pin 12 (counter in).
3. The operations counter should increment.

### Block Raise/Block Lower/Deadband

1. Set Block Raise to 126.0 V.
2. Set Block Lower to 114.0 V.
3. Set the unit to display the Bias Voltage screen.
4. Press **ENT**.
5. Increase voltage to 126.5 V. BR should be displayed on the screen.
6. Increase voltage to 128.5 V. FL is displayed on the screen.
7. Decrease voltage to 113.5 V. BL is displayed on the screen.

—Bench Test Complete—

---

## 7.2 Check-out Procedure

---

■ **NOTE:** All Beckwith Electric units are fully calibrated at the factory. There is no need to recalibrate the units before initial installation.

### Applying Power

1. Remove any external connection between Pin 1 (voltage input) and Pin 8 (motor power input).
2. Using a voltmeter, ensure that the voltage applied to Pin 1 is nominal 120 V ac with respect to Pin 3 (neutral).

▲ **CAUTION:** Do not reverse the ground and hot wires when connecting an external source.

3. Apply motor auxiliary voltage to Pin 8 (motor power input) and Pin 3 (neutral).
4. Verify that the motor runs in the proper direction when conditions of sensed voltage result in activation of Raise and Lower outputs.

● **WARNING:** In no case should the load current circuit be interrupted with the regulator or transformer energized.

● **WARNING:** Do not remove auxiliary current transformers without shorting the current inputs. Death or severe electrical shock can occur.

5. As shown in Figure 7-2, Setup for Current Checkout Procedures, temporarily place a shorting device across the LDC-CT secondary to short the line drop compensator circuit, and place another shorting device to short the circulating current paralleling output, for the load current check.
6. Insert an ammeter between the polarity input and Pin 4.
7. Open the load current shorting device and with a known load on the transformer or regulator, measure the current in the load current circuit to ensure that this current is correct for 0.2 A full load.

▲ **CAUTION:** The current input to the control is rated at 0.2 A continuous, 0.4 A for two hours, and 4.0 A for 1 second.

8. Replace the shorting device across the load current input and remove the ammeter.
9. Reconnect polarity to the unit and remove both jumpers. The Line Drop Compensator will be activated. Correct CT polarity can be checked by simply incorporating sufficient +R compensation. The regulator should time out and run so as to raise the output voltage.

### 7.3 Operational Test

1. Set VT Ratio Correction = 0 V; CT/VT phasing = 0° from the appropriate screen in the software.
2. Return to the Local Voltage screen.
3. Apply 120.0 V ac to Pin 1 (hot) and Pin 3 (neutral) of the adapter panel.
4. Verify local voltage = input voltage  $\pm 0.3$  V.
5. Apply 100.0 mA in-phase current to Pin 4 (load current-polarity) and Pin 2 (load current-return).
6. Verify Control Load I = 100 mA and Power Factor = 1.0  $\pm 0.02$  from the appropriate software screens.
7. Apply 100.0 mA 90° leading current to Pin 5 (circulating current-polarity) and Pin 6 (circulating current-return).
8. Verify Control Circ I = 100.0 mA  $\pm 2$  mA.
9. Verify the  $\uparrow$ ,  $\downarrow$  and ENT pushbuttons function properly.
10. De-energize the current source.

—Checkout Procedure Complete—

### 7.4 In-Service Test

1. Set the M-2001C Tapchanger Control to display the Bias Voltage screen.
2. Press **ENT**.
3. Use the  $\uparrow$  and  $\downarrow$  pushbuttons to cause **RAISE** and **LOWER** outputs.

If either output is blocked, verify that the unit is not at the maximum tap position.

4. Press **ENT** to return to the Local Voltage screen.

—In-Service Test Complete—

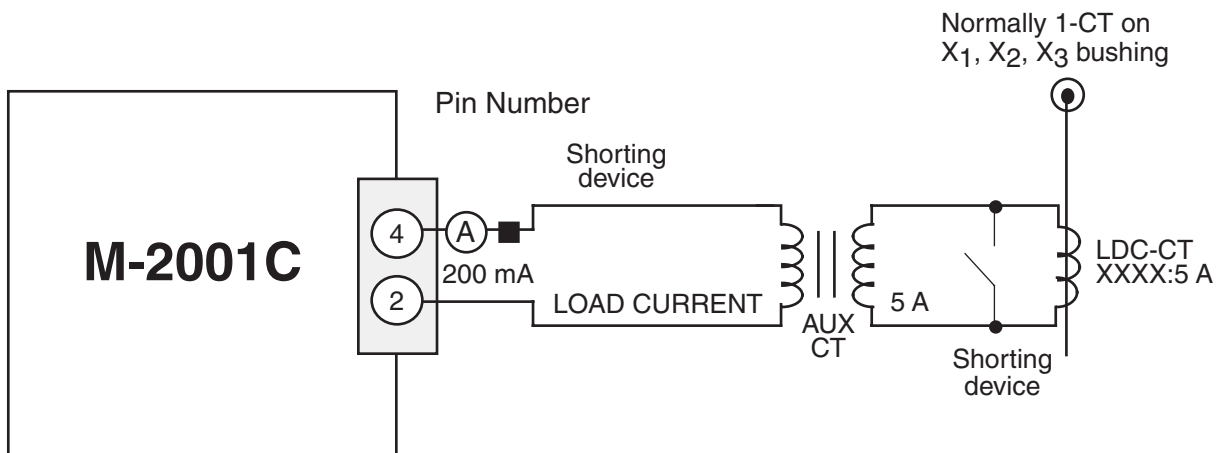

■ **NOTE:** Pin numbers indicated above are accurate for the M-2050B Mounting Kit only; check the Application Guide of the specific adapter panel used for proper pin numbers.

Figure 7-2 Setup for Current Checkout Procedure

**This Page Left Intentionally Blank**

# 8 Design Changes

8.0	Design Changes .....	8-1
-----	----------------------	-----

---

## 8.0 Design Changes

---

Beckwith Electric maintains a system whereby customers can obtain information concerning all design changes to our units. Documentation on each unit is kept on file by model number, serial number, and software version (if applicable).

Each unit has a model number consisting of a letter and four numbers. Significant enhancements are marked with a suffix letter. It must be possible to use any later version as a replacement for an earlier version. The opposite may not be true because of features added. If later units are not fully interchangeable for older units, a change in the model number is made.

The release of the M-2001C (BASE-R) indicates that significant enhancements were made to the unit from the M-2001B model. These enhancements are:

- EXIT button added
- LDC LED added
- Voltage Reduction LED added
- LCD or Vacuum Fluorescent Displays
- A or B regulator type selection added
- Third type of operational counter configuration ("Count Window" added)
- SCADA blocking input added (uses non-seq input)
- Enable/Disable of select status screens added
- Bandwidth range changed from 6.0 to 10.0 volts
- Display time out increased to 15 minutes

**This Page Left Intentionally Blank**

# 9 M-2029A TapTalk®

9.0	Availability .....	9-2
9.1	Hardware Requirements .....	9-2
9.2	Installing TapTalk .....	9-2
9.3	Communications using Direct Serial Connection .....	9-3
9.4	Communications using a Modem .....	9-4
9.5	Communications with Multiple Controls .....	9-6
9.6	Cautions .....	9-7
9.7	Overview of Operation .....	9-9
9.8	Communication Cables .....	9-37
9.9	TapPlot™ Analysis Software .....	9-39



This chapter contains information necessary to configure and interrogate Beckwith Electric digital tapchanger controls using a personal computer, running M-2029A TapTalk® Communications Software. TapTalk is backward compatible with older Digital Tapchanger Controls. Firmware version is displayed when power is applied to the control or through the display panel. While the software has been carefully designed for easy use and installation, we suggest that first-time users acquaint themselves with its operation prior to use by carefully reading this chapter.

---

## 9.0 Availability

---

M-2029A TapTalk Communications Software is available on CD-ROM. Also included on the CD-ROM is the companion Instruction Book in Adobe® Acrobat™ (\*.pdf) format.

---

## 9.1 Hardware Requirements

---

TapTalk will run on any IBM-compatible PC that provides at least the following:

- Microsoft® Windows™ 95, 98, NT 4.0, 2000 or XP
- one CD-ROM drive
- one serial (RS-232) communications port
- for remote communication, either a modem or TCP/IP connection is required

### Hardware Required for Modem Communication

In order to use TapTalk to communicate with a Beckwith Electric digital tapchanger control using a modem, the control must be equipped with the following:

- A compatible modem (300, 600, 1200, 2400, 4800, 9600, or 19200 baud)
- Serial modem cable with 9-pin connector for the control and the applicable connector for the modem or fiber-optic cable with RS-232 converter.

Similarly, the host computer must also have access to a modem and an appropriate cable.

■ **NOTE:** Pinouts for communications cables are provided in Section 9.8, Communication Cables.

### Hardware Required for Direct Serial Communication

To use TapTalk to communicate with a Beckwith Electric digital tapchanger control using a direct serial connection, a serial “null modem” cable is required with a 9-pin connector (DB9P) for the control and an applicable connector for the computer (usually DE9S or DE25S).

---

## 9.2 Installing TapTalk

---

The TapTalk installation program has been written to overwrite previous versions of TapTalk. However, considering variations in installed software, hardware and operating systems, if you are upgrading from a previous version of TapTalk, it is recommended that any older versions of the TapTalk program be removed before installing the new TapTalk.

TapTalk runs with the Microsoft Windows 95, 98, NT 4.0, 2000, or XP operating system. Familiarity with Windows is important in using TapTalk, as the conventions defined in the Windows documentation are strictly followed therein.

TapTalk will be installed on the host PC’s hard disk. While it does not require special installation procedures, an installation utility has been provided to make the process easier.

To install TapTalk:

1. Insert the TapTalk software into your CD-ROM drive.
2. Select **Run** from the **Start Menu**.
3. In the **Run** dialog box, initiate software installation by typing **D:\Setup.exe** (or other drive designator:\Setup.exe, depending on the letter designation for the CD-ROM drive).
4. The Installation Wizard will prompt the user through the installation process. After installation, the TapTalk program icon (located in the Becoware folder) can be placed on the desktop (Figure 9-1).

### Starting TapTalk

1. Select the TapTalk program-item icon from the Becoware group in the Program Manager, or select TapTalk from the program list using the **Start Menu**. The TapTalk toolbar is displayed along with the **Communication Access** dialog screen (Figure 9-8).

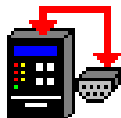

Figure 9-1 TapTalk Program-Item Icon

When the control is first energized, the quickest way to properly initialize the control prior to entering the setpoints is to set the real-time clock. This action will initiate a prompt from the control to perform a reset operation for the following items:

- Demand Metering
- Energy Metering
- Drag Hands Reset Registers
- Resettable Operations Counter

It is then easy to proceed with the remainder of the control setup.

---

### 9.3 Communications using Direct Serial Connection

---

To use TapTalk to interrogate, set, or monitor the M-2001C (BASE-R) Digital Tapchanger Control using a direct serial connection, the control and the TapTalk software must be setup for serial communications. Elements of the setup process include protocol definition and communication port settings. Refer to Section 4.9, Protocols/Communication, Section 6.4, Communication Port, and Figure A-5, Communication Screens, for additional setup information. The steps necessary to configure the control, and TapTalk, for communication using a direct serial connection are outlined below.

#### Configuring the Control for Communication Using Direct Serial Connection

1. Ensure the control is energized.
2. From the Human-Machine Interface (HMI) panel, located on the front of the control, access the **Configuration** Menu, and set the control's **Baud Rate** (19,200 bps maximum) to a value that can match the baud rate of the PC.
3. From the control's **Configuration** Menu, set the **Communication Address** of the control to a number not used by any other control sharing the same modem (serial connections can be shared through the use of a communications line splitter, refer to Figure 9-4).

■ **NOTE:** All M-2001 Series Digital Tapchanger Controls are shipped with communications password disabled (set to 0000).

4. If desired, set the **Communication Password**.
5. The M-2001C (BASE-R) only supports BECO 2200 Communication Protocol. Protocol configuration is not required.

▲ **CAUTION:** Control serial communication is disabled when the control is in the local mode. (M-2001C (BASE-R) may be set to disable local control mode remote communication blocking)

6. Position the control menu to the **EXIT** Screen, then select **ENT** (the control will display a blank screen even though the unit remains operational).

■ **NOTE:** Communication cable connections are provided in Section 9.8, **Communication Cables**.

▲ **CAUTION:** Successful operation cannot be guaranteed for RS-232 cable lengths exceeding 50 feet in length. Every effort should be made to keep cable length as short as possible (< 50 feet).

7. Connect the PC to the desired control Com Port utilizing a standard RS-232 cable.

#### Configuring TapTalk® for Communication using Direct Serial Connection

After the control has been correctly configured for serial communication, TapTalk and the PC can be configured. TapTalk utilizes the resident Windows™ operating system COM port configuration setup features. Com Port settings made in either the Windows environment or from TapTalk affect all programs on the PC that have direct serial communication.

1. Start the TapTalk program, TapTalk will display the **Access** dialog screen (Figure 9-8).
2. Select **Serial COM Port** from the **PC Communication Device** drop-down menu.
3. Ensure that the correct COM port is displayed.
4. Some devices that include extended service ports require a character string prior to the COM Port value for COM10 and higher. If applicable, then check the appropriate box and input the appropriate character string.

## 9.4 Communications using a Modem

To use TapTalk to interrogate, set or monitor the M-2001C (BASE-R) Digital Tapchanger Control using a modem, the control and the TapTalk software must be setup for modem communications. Elements of the setup process include protocol definitions, communication port settings and modem commands. Refer to Section 4.9, Protocols/Communication, Section 6.4, Communication Port, and Figure A-5, Communication Screens, for additional setup information. The steps necessary to configure the control and TapTalk for communication using a modem are outlined below.

### Configuring the Control for Communication Using a Modem

1. Ensure the control is energized.

■ **NOTE:** Any compatible modem may be used; however, it is not recommended to communicate at less than 2400 bps.

2. From the control's **Configuration** Menu, set the control's **Baud Rate** (19200 bps maximum) to a value that can be matched by the baud rate of both the control's modem and the PC modem.
3. From the control **Configuration** Menu, set the **Communication Address** of the control to a number not used by any other control sharing the same modem (serial connections and modems can be shared through the use of a communications line splitter, refer to Figure 9-4).

■ **NOTE:** All M-2001 Series Digital Tapchanger Controls are shipped with communications password disabled (set to 0000).

4. If desired, set the **Communication Password**.
5. The M-2001C (BASE-R) only supports BECO 2200 Communication Protocol. Protocol configuration is not required.

▲ **CAUTION:** Control remote communication is disabled when the control is in the local mode. (M-2001C (BASE-R) may be set to disable local control mode remote communication blocking).

6. Position the control menu to the **EXIT** Screen, then select **ENT** (the control will display a blank screen even though the unit remains operational).

■ **NOTE:** Communication cable connections are provided in Section 9.8, Communication Cables.

▲ **CAUTION:** Successful operation cannot be guaranteed for RS-232 cable lengths exceeding 50 feet in length. Every effort should be made to keep cable length as short as possible (< 50 feet).

7. Connect the modem to the desired control COM Port utilizing a standard RS-232 cable.
8. Connect the modem to the desired telephone line, then energize the modem.

■ **NOTE:** The control does not issue or interpret modem commands, or adjust modem baud rate. The control should be considered a "dumb" peripheral. The control communicates utilizing 1 Start, 8 Data and 1 Stop Bit.

9. Configure the modem connected to the control to the following AT Command settings (these settings are mandatory):

- E0 No Echo
- Q1 Don't return result code
- &D3 ON to OFF DTR, hang-up and reset
- &S0 DSR always on
- &C1 DCD ON when detected
- S0=2 Answer on second ring
- V0 Number Codes

There are variations in the AT commands supported by modem manufacturers. The following commands may be required at the modem:

- &Q6 Constant DTE to DCE speed
- N0 Answer only at specified speed
- \J Disable serial data rate adjust
- \Q3 Bidirectional RTS/CTS control
- \N0 Normal mode
- &B1 Fixed serial port rate
- &D2 ON to OFF DTR, hang up and reset
- B1 U.S. Answer Tone

It is recommended that the user save these settings to the profile that is recalled at boot-up.

The modem connected to TapTalk® should be set as follows:

- E0 No Echo
- Q0 Return Reset Code
- V1 Verbal Codes

### Configuring TapTalk for Communication using a Modem

After the control and the control's modem have been correctly configured for remote communication, TapTalk and the PC modem can be configured. TapTalk utilizes the resident Windows™ operating system modem configuration setup features. Modem, Com Port and dialing settings made in either the Windows environment or from TapTalk affect all programs on the PC that have modem communication capabilities.

■ **NOTE:** The following instructions are based on the existence of an installed and functioning modem. If the PC is *not* equipped with a functioning modem then install a modem following the modem manufacturers instructions and then return to this instruction to configure TapTalk.

1. Start the TapTalk program, TapTalk will display the **Communication Access** (Serial) dialog screen (Figure 9-8).
2. Select modem from **PC Communication Device** section, TapTalk will display Figure 9-9, **Communication Access** (Modem) Dialog Screen, then proceed as follows to input information required for modem communication:
  - a. Ensure that the correct modem is displayed, then select **Setup**, TapTalk will display the **Modem Communication Setup** screen (Figure 9-10).
  - b. Select **Add Number**, TapTalk will display the **Edit Phone Book** dialog screen (Figure 9-11).
  - c. Input the telephone number of the remote modem associated with the control, then select **OK** to save the telephone number to the **Phone Book** or **Cancel** to return to the **Modem Communication Setup** screen.

■ **NOTE:** The **Configure Line** and **Dialing Properties** section of the **Modem Communication Setup** screen are used to access Windows modem settings. If it becomes necessary to modify modem settings ensure that the Baud Rate, Data bits, Parity and Stop Bit values required by TapTalk are maintained.

- d. Select **Configure Line...**, TapTalk displays the **Modem Plug and Play Properties** dialog screen (Figure 9-2).

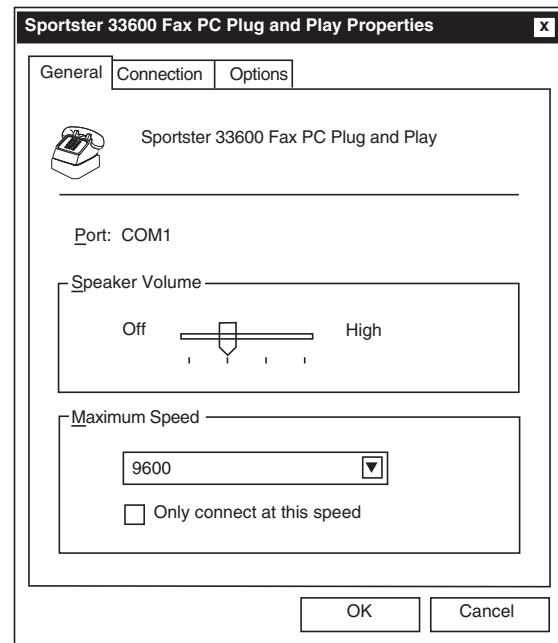

Figure 9-2 Modem Plug and Play Properties Dialog Screen

- e. Select the **Connection** tab (or **Advanced** for Windows 2000 or later), TapTalk displays the **Connection** dialog screen, then enter the following:

Data Bits = **8**

Parity = **None**

Stop Bits = **1**

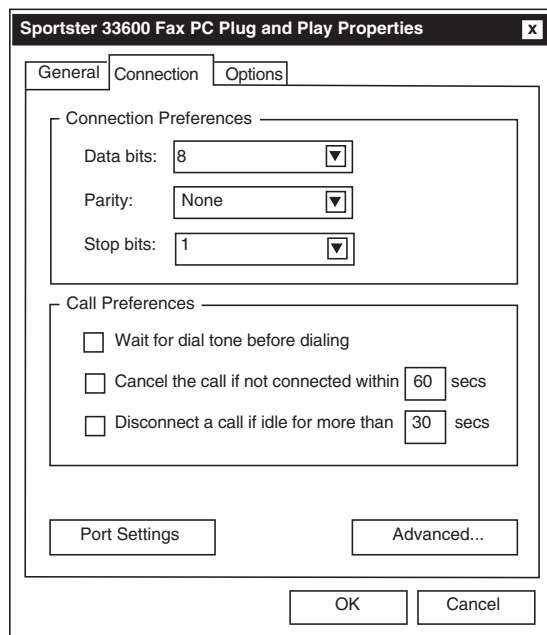

Figure 9-3 Modem Plug and Play Connection Dialog Screen

- f. Select **OK** to save **Connection Preferences** or **Cancel** to return to the **Modem Plug and Play Properties** dialog screen.
  - g. Select **OK** to save modem communication settings or **Cancel** to return to the **Control Access** dialog screen.
5. TapTalk is now configured to communicate with M-2001 Series controls using a modem.

## 9.5 Communications with Multiple Controls

▲ **CAUTION:** Each control connected to either a direct or modem connection configuration must have a unique communications address. If two or more controls share the same address, corrupted communication will result.

The remote addressing capability of TapTalk and the digital tapchanger control allows multiple controls to share a direct or modem connection. This can be done with standard RS-232 connections using a communications line splitter (see Figure 9-4, Multiple Control Addressing Using Communications Line Splitter). See Chapter 3, **Setting the Control** for more information on specific menu commands.

A control address of zero is a “wild card” that will illicit a response from all controls on a shared connection and result in corrupted communication.

With these arrangements, any control can be selected from within TapTalk by specifying its unique communications address, ranging from 1 to 200. The communications address must have previously been set from the control’s front panel.

---

## 9.6 Cautions

---

### Control and TapTalk® Compatibility

Every attempt has been made to maintain compatibility with previous control software versions. In some cases (most notably, with older controls), compatibility cannot be maintained. However, TapTalk should work correctly with more than one version of the M-2001 Series Digital Tapchanger Controls on a single bus, provided that the controls are all set to use the same protocol. If there is any question about compatibility, contact the factory.

### Control Priority

Control conflicts will not occur as local commands initiated from the front panel receive priority recognition. While the unit is in local mode, communication via the serial ports is suspended, unless local mode is disabled. TapTalk displays an error message to indicate this fact.

### Time and Date Stamping

Time and date stamping of events is only as useful as the validity of the control's internal clock. Under the **Utilities** menu, the Set Control Date/Time command allows you to manually set the control's clock. For reference, the computer's clock is also displayed.

### Local Mode

In the control's configuration menu, there is an option to enable or disable **Local Mode**. If Local Mode is disabled, the user may access the control via the local screen as well as through communication SCADA.

### Serial Port Connections

If the serial port is connected to something other than a modem and a TapTalk modem command is executed, the results are unpredictable. In some cases, the computer may have to be reset.

If the computer's communications options (baud rate, serial communications port, and communications address) do not match those on the control, the control will return an error message.

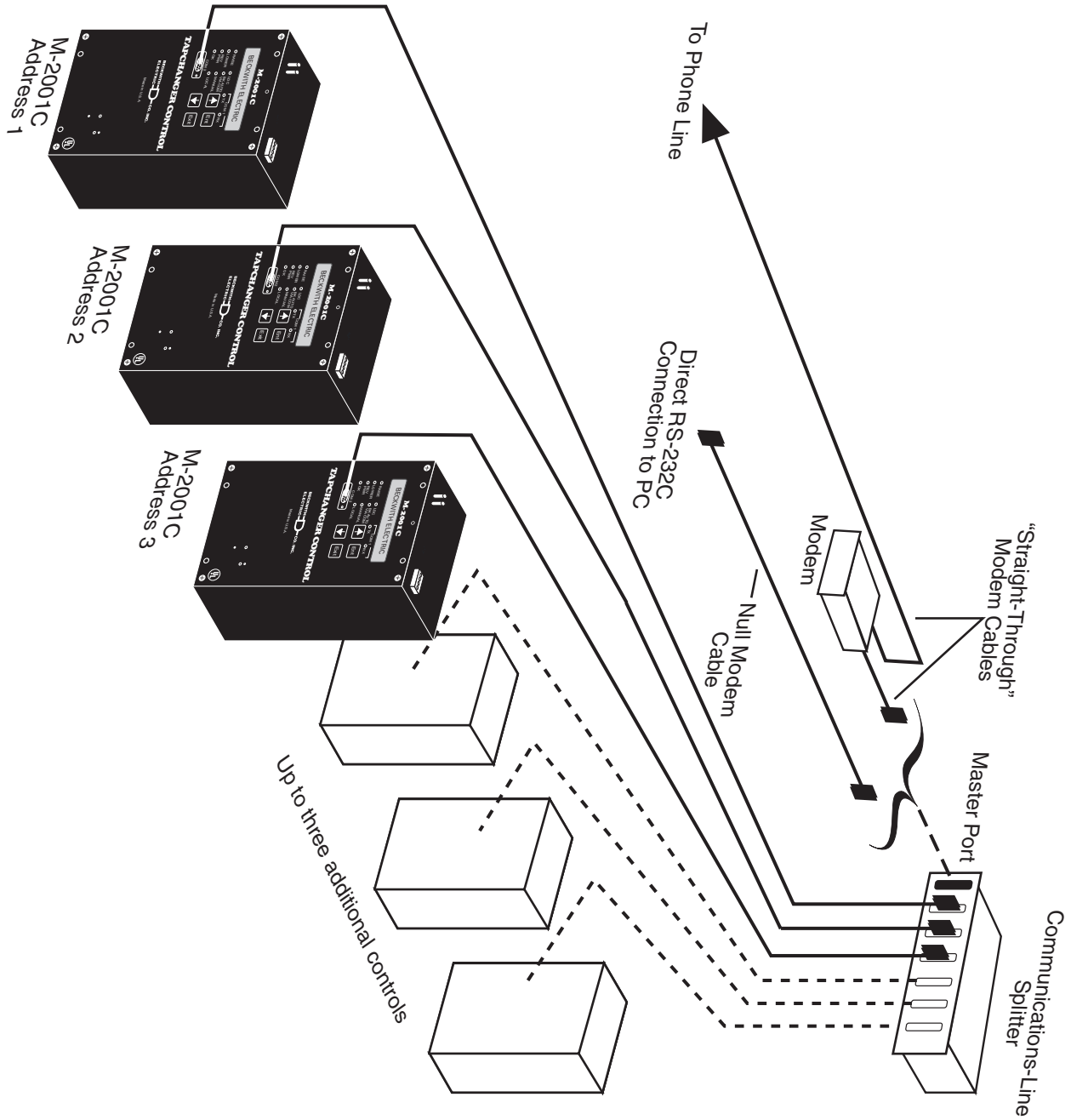
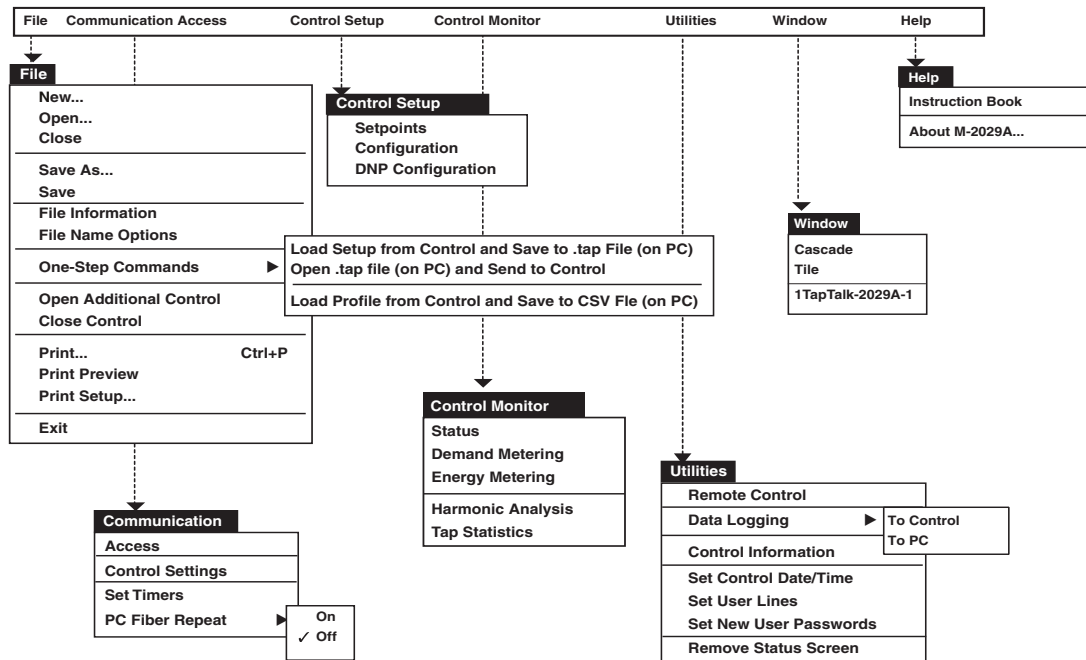

Figure 9-4 Multiple Control Addressing Using Communications-Line Splitter

## 9.7 Overview of Operation

■ **NOTE:** If not connected and no file is open, items relating to settings, utilities, or monitoring are disabled. If not connected but a file is open, monitoring and utilities screens are displayed without data (Tap and Harmonics display simulated data.)

Once installed, the TapTalk® program-item icon is available from the Program Manager and TapTalk can be run like any other Windows™ program. (The installation utility places TapTalk in a Program Manager group named Becoware.) When TapTalk is run, the following menu bar is displayed. Each of the main menu selections is discussed briefly below.



■ **NOTE:** Menu selections and corresponding dialog screens which are unavailable will be greyed-out in display.

Figure 9-5 TapTalk Menu Selections

### File

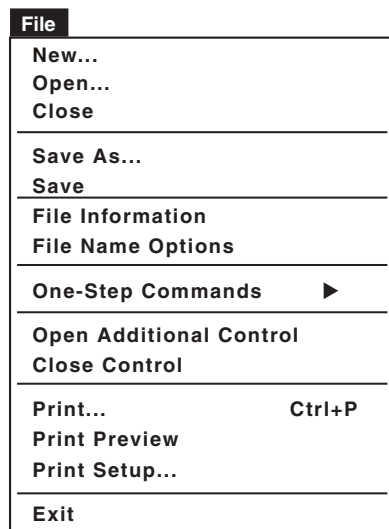

The **File** toolbar item provides the user with the ability to perform the following functions:

- **New...** Opens the File Information Box to allow the user to pick the Serial #, User Lines, Version Mod and other options.
- **Open...** Opens the file browser window to allow the user to select an existing file. It will not allow the user to create a new file.
- **Close** – Closes the open file in the control window.
- **Save As...** Allows the user to save the open file with a different file name.
- **Save** – Saves the open file.
- **File Information** – Displays the file name, user lines, firmware version, Mod number associated with the open file.



- **File Name Options** – Allows user to select the parameters that will be included in the suggested file name.
- **One Step Commands** –
  - Load Setup from Control and Save to \*.tap File (on PC):** When connected to a control and no file is previously open, this function allows the user to recall the setpoints, configuration and DNP configuration (if applicable) and save the data to a file in one step.
  - Open \*.tap File (on PC) and Send to Control:** When connected to a control and no file is previously open, this function allows the user to open a file and send the setpoints, configuration and DNP configuration (if applicable) to the control in one step.
  - Load Profile from Control and Save to CSV File (on PC):** When connected to a control and no file is previously open, this function allows the user to recall the control profile and save the data to a comma-separated value file.
- **Open Additional Control** – Opens another TapTalk® window to allow the user to connect to multiple controls.
- **Close Control** – Closes the active window.
- **Print...** Prints the control information.
- **Print Preview** – Displays a preview of what will be printed.
- **Print Setup...** Allows the user to set up printer options.
- **Exit** – Exits the TapTalk program.

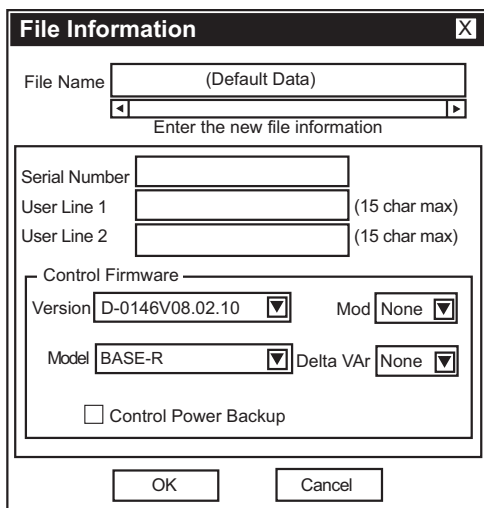

Figure 9-6 File Information Dialog Screen

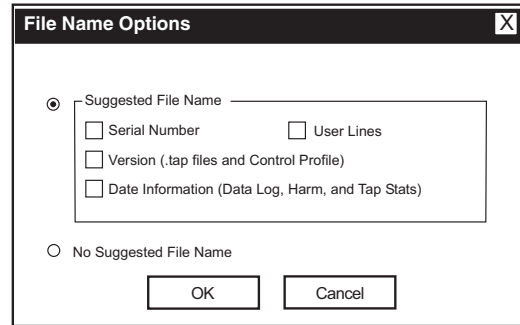
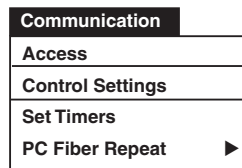

Figure 9-7 File Name Options Screen

**Communication**



The **Communication** menu provides the user with access to the screens that are necessary to set control communication parameters.

The **Access** menu selection initiates the **Access** dialog screen. The user is prompted to input the necessary communications information to open serial, modem or ethernet (TCP/IP) communications with the target control.

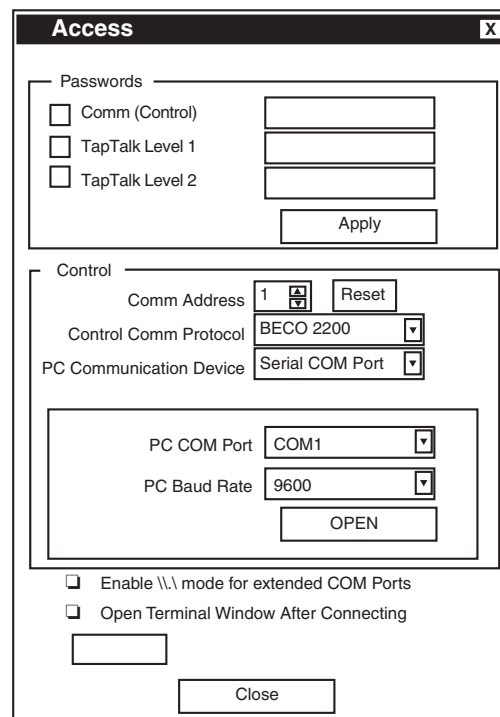

Figure 9-8 Communication Access (Serial) Dialog

To establish or change PC or modem communication parameters perform the following:

1. Ensure that communication with the control is closed.
2. Select **Access** from the **Communication** menu to display the **Access** dialog screen.

■ **NOTE:** All M-2001 Series Digital Tapchanger Controls are shipped with the communication password disabled (set to 0000).

3. Select the desired password protection (Comm, TapTalk Level1, TapTalk Level2) by checking the corresponding checkbox.
4. Enter the required passwords. See Utilities/Set New User Passwords section of this chapter.

▲ **Caution:** Entering a Comm Address of zero (0) where multiple controls can be addressed will cause communication to be corrupted.

5. Input the **Comm Address** identification number (between 1 and 200) of the desired control.
6. Select **Control Comm Protocol** (BECO 2200)
7. Select **PC Communication Device** (Serial Comm Port, Modem or TCPIP)
8. If **Serial COM Port** has been selected, then select the desired COM Port and Baud Rate.
9. If **Modem** has been selected, then proceed as follows to input information required for modem communication:

Figure 9-9 Communication Access (Modem) Dialog

- a. Ensure that the correct modem is displayed, then select **Setup**, TapTalk will display the **Modem Communication Setup** screen.

Figure 9-10 Modem Communication Setup

- b. Select **Add Number** or **Edit Number**; TapTalk® will display the **Edit Phone Book** dialog screen.

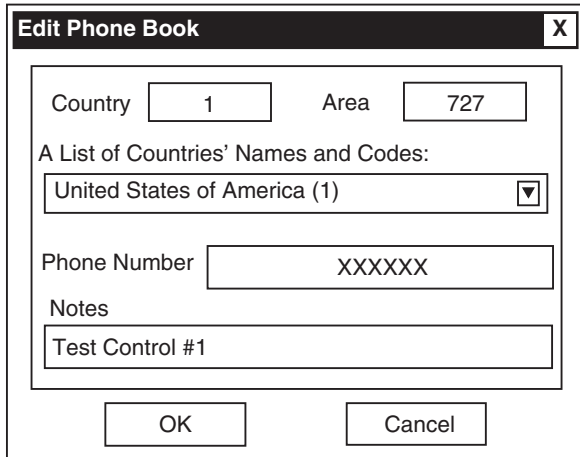

Figure 9-11 Edit Phone Book Dialog Screen

- c. Input the telephone number of the remote modem associated with the control, then select **OK** to save the telephone number to the Phone Book or **Cancel** to return to the **Modem Communication Setup** screen.
- d. If it becomes necessary to modify modem Windows™ settings, then select either the **Configure Line** or **Dialing Properties** section of the **Modem Communication Setup** screen to access modem settings.
- e. Select **OK** to save modem communication settings or **Cancel** to return to the **Communication Access** dialog screen.
- f. If terminal commands are to be issued to the corresponding terminal device (via modem), then check the **“Open Terminal Window After Connection”** box on the **Access** Dialog Screen.

When connected to another terminal device, the Terminal Window allows the user to send messages or commands. Outgoing communications are displayed in the top pane and incoming messages are displayed in the bottom two panes, in ASCII and HEX format.

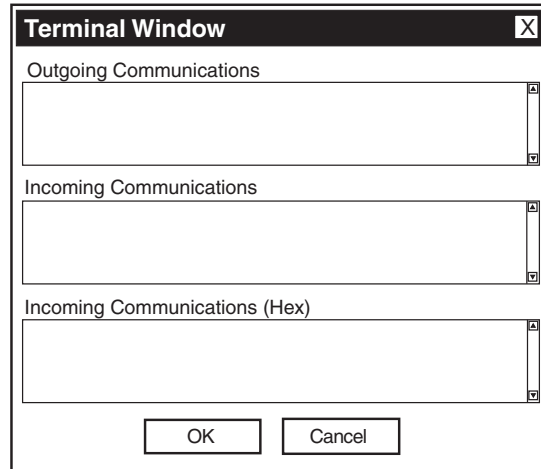

Figure 9-12 Terminal Window

- 10. If TCP/IP has been selected, then input an IP port value of 8800 (for internal ethernet cards) and the desired IP Address. If a third-party device (i.e., Lantronix DS-10) is used, then the port will have to match the setting of the device.

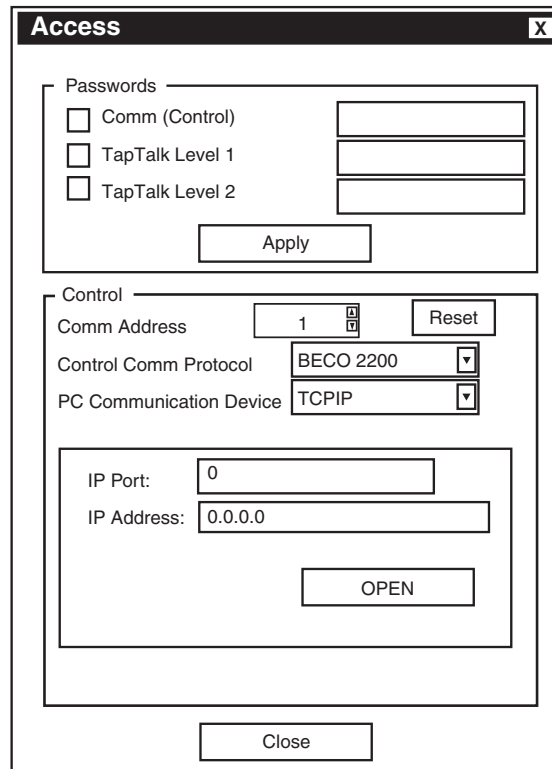

Figure 9-13 TCP/IP Communication Setup

11. To open serial communications, select **Open**. The passwords are sent to the control.
  - a. If proper passwords and Control Address have been sent, TapTalk® will respond with a confirming dialog screen.
  - b. If improper passwords and Control Address have been input, TapTalk will respond with an error screen.
12. To open modem communications, select **Dial**. The passwords and Control Address are sent to the control.
  - a. If proper passwords and Control Address have been sent, TapTalk® will respond with a confirming dialog screen.
  - b. If improper passwords and Control Address have been input, TapTalk will respond with an error screen.
13. To open Ethernet communications, select **Open**. The IP Address, Control Address and passwords are sent to the control.
  - a. If proper IP Address, Control Address and passwords have been sent, TapTalk will respond with a confirming dialog screen.
  - b. If improper IP Address, Control Address and passwords have been input, TapTalk will respond with an error screen.

### Multiple Control Addressing

To address additional controls at the same location (Not applicable to Ethernet connections), the user must reset the control address from the Communication Access Screen (Figure 9-8). When RESET is selected, TapTalk will respond with a confirming dialog screen, shown below. As long as communication to the remote location is maintained, the user can switch between controls.

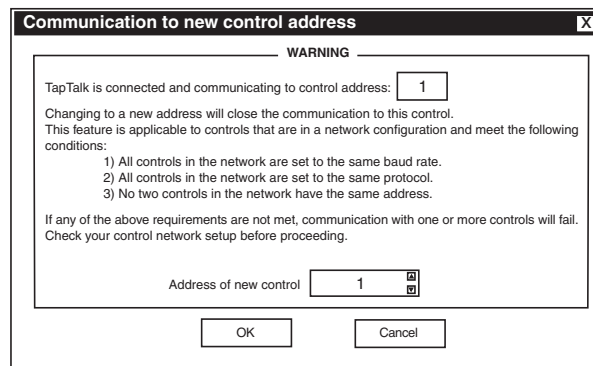

Figure 9-14 Communication To New Control Address Dialog Screen

### Control Settings

The **Control Settings** menu selection initiates the **Control Settings** dialog screen which allows the user to set protocols and toggle fiber repeat on and off.

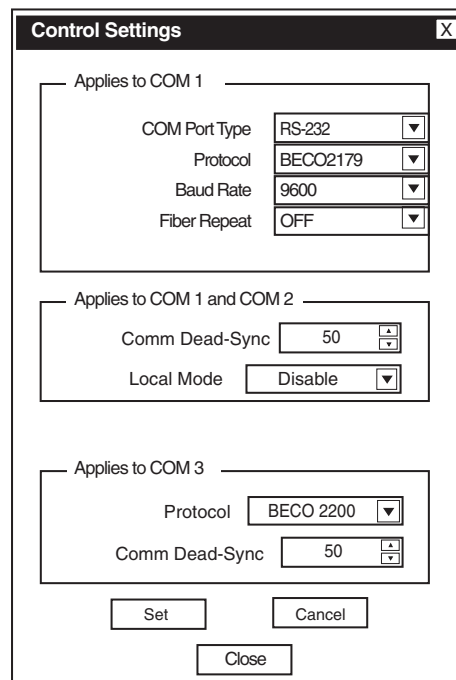

Figure 9-15 Control Settings Dialog Screen

**Fiber Repeat COM1** is not available with M-2001C (BASE-R), and will be greyed out in display.

**COM Port Type** is not available with M-2001C (BASE-R), and will be greyed out in display.

**COM1 Protocol** is not available with M-2001C (BASE-R), and will be greyed out in display.

**COM1 Baud Rate** is not available with M-2001C (BASE-R), and will be greyed out in display.

**Local Mode** – Allows control of reading/writing setpoints and configurations using communications. There are 4 settings associated: **Disable**, **Read Only**, **Always Read Only**, and **No Read or Write**. When set to **Disable**, read/write communication will be available at all times. When set to **Read Only**, read/write communications will be available only when the front panel of the control is inactive. If the front panel is active, only reads via communications will be allowed. When set to **Always Read Only**, only reads via communications will be allowed, regardless of whether the front panel is active or not. When set to **No Read or Write**, read/write communication will be available only when the front panel to the control is inactive. If the front panel is active, no communication will be allowed.

**Dead-Sync Time** – This time delay improves robust operation when communication lines are intermittent. Communication dead-sync time is the time that the control will wait from the last received character and continue without attempting to resynchronize.

**Set Timers**

The **Set Timers** menu feature initiates the display of the Set Timers dialog box which displays the current timeout values, and allows the user to change timing values.

The **Time Out** setting determines time period at which TapTalk will stop attempting to establish communication with the target control.

The **Wait Time** setting determines the time between individual commands when multiple commands are being performed. If errors occur, then increase the wait time setting before adjusting the timeout setting.

This feature also includes the capability to adjust the timing (**Monitoring Timer**) at which TapTalk® refreshes control monitoring screen parameters.

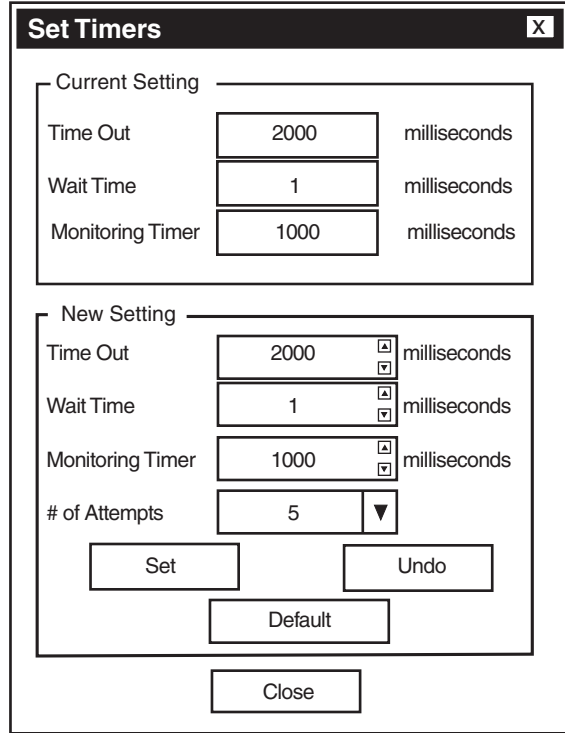

Figure 9-16 Set Communication Timers Screen

**PC Fiber Repeat** menu selection allows user to toggle Fiber Repeat on and off.

The PC Fiber Repeat feature is used only when several controls are connected using a fiber optic loop network. Selecting **On** allows masking of the sender’s returned echo. Control Setup

## Control Setup

Setpoints  
Configuration  
DNP Configuration

The **Control Setup** menu selection provides the user with means to access and modify **Setpoints**, **Configuration** and **DNP Configuration**.

### Control Setup/Setpoints

The **Setpoints** submenu item displays the **Setpoints** Dialog Screen. The **Setpoints** screen includes the Control Identification Number, the Comm Address, and User Lines #1 and #2 information. The setpoint information displayed is from the control or from an open TapTalk file.

Elements of the **Setpoints** screen are described on the following page.

The **Setpoints** screen commands include:

- **Read from Control** – This command is available to read setpoints from the target control when the Setpoints screen is selected to “Read From File”. When this command is selected, the button will change to “Connected to Control.”
- **Write to Control** – This command writes the values displayed/modified on the screen to the control.
- **Update File/Update Default** – If an existing file is open, **Update File** will write the values to the file. If a new file with default values is open, **Update Default** will update the values in RAM to be saved later.
- **Read Setpoints from File/Read Default Setpoints** – If a file is open, **Read Setpoints from File** reads the values from the open file. When no new file is open, **Read Default Setpoints** reads the default values from RAM.
- **Undo/Reload** – This command reloads setpoints from either the control or TapTalk® file (whichever is selected) prior to any **Write to Control** or **Write to File** command.

**Setpoints**
**X**

M-2001C

Comm Add: 1

xxxxxxxxxxxxxxxx

xxxxxxxxxxxxxxxx

POWER FLOW

Forward

Band Center	120	V
Band Width	2	V
LDC Resistance	0	V
LDC Reactance	0	V
Time Delay	30	sec
Inverse Time Delay	30	sec

Reverse

Band Center	120	V
Band Width	2	V
LDC Resistance	0	V
LDC Reactance	0	V
Time Delay	30	sec
Inverse Time Delay	30	sec

VOLTAGE

Limit/Runback

Block Raise	128	V
Block Lower	114	V
Dead Band	2	V
Current Limit	400	mA

Reduction

Step #1	2.5	%
Step #2	5	%
Step #3	7.5	%

TAP LIMITS

Block Raise 16 Raise

---

Block Lower 16 Lower

MISCELLANEOUS

LDC-Z	0	V
Output Pulse Width	1.5	sec

Connected to Control

Read Setpoints from File or Read Default Setpoints

Write to Control

Update File or Update Default

Undo/Reload

Close

Figure 9-17 Setpoints Dialog Screen

■ **NOTE:** TapTalk® is designed to communicate with all M-2001 Series controls. However, due to the generational differences between controls, some features may not be available on the target control, and will appear greyed out in the display.

## Setpoints

### Power Flow/Forward

**Band Center** – Adjustable from 100 V to 135 V in 0.1 V increments with a factory setting of 120 V.

**Band Width** – Adjustable from 1 V to 10 V in 0.1 V increments with a factory setting of 2.0 V.

**LDC Resistance** – Adjustable from –24 V to +24 V in 1 V increments with a factory setting of 0 V.

**LDC Reactance** – Adjustable from –24 V to +24 V in 1 V increments with a factory setting of 0 V.

**Time Delay** – Adjustable from 1 sec. to 120 sec. in 1 second increments with a factory setting of 30 sec.

**Inverse Time Delay** – Adjustable from 1 sec. to 120 sec. in 1 second increments with a factory setting of 30 seconds.

### Power Flow/Reverse

**Band Center** – Adjustable from 100 V to 135 V in 0.1 V increments with a factory setting of 120 V.

**Band Width** – Adjustable from 1 V to 10 V in 0.1 V increments with a factory setting of 2.0 V.

**LDC Resistance** – Adjustable from –24 V to +24 V in 1 V increments with a factory setting of 0 V.

**LDC Reactance** – Adjustable from –24 V to +24 V in 1 V increments with a factory setting of 0 V.

**Time Delay** – Adjustable from 1 sec. to 120 sec. in 1 second increments with a factory setting of 30 sec.

**Inverse Time Delay** – Adjustable from 1 sec. to 120 sec. in 1 second increments with a factory setting of 30 seconds.

### Voltage/Limit Runback

**Block Raise** – Over voltage limit is adjustable from 95 V to 135 V in 0.1 V increments with a factory setting of 128 V.

**Block Lower** – Under voltage limit is adjustable from 95 V to 135 V in 0.1 V increments with a factory setting of 114 V.

**Dead Band** – Adjustable from 1 V to 4 V in 0.1 V increments with a factory setting of 2.0 V.

**Current Limit** – Depending on the Current Transformer configuration point, adjustable from 200 mA to 640 mA (200 mA CT), in increments of 1 mA, from 1.0 A to 3.2 A (1 A CT), in increments of 0.1 A, or from 5.0 A to 16.0 A (5 A CT) in increments of 0.1 A. If the value of the current exceeds the current limit setpoint, the unit will not permit automatic control in either the raise or lower direction. Factory setting is 400 mA.

### Voltage/Reduction

**Step 1** – First of three independent steps of voltage reduction adjustable from 0% to 10% in 0.1% increments of the bandcenter setpoint. Factory setting is 2.5%.

**Step 2** – Second voltage reduction step, adjustable from 0% to 10% in 0.1% increments of the bandcenter setpoint. Factory setting is 5.0%.

**Step 3** – Third voltage reduction step, adjustable from 0% to 10% in 0.1% increments of the bandcenter setpoint. Factory setting is 7.5%.

### Tap Limits

**Block Raise/Lower** – For M-2001C (BASE-R) controls, both are adjustable from the Tap Maximum configuration point to the Tap Minimum value in 1 step increments (Tap Limit Block Raise cannot be lower than Tap Limit Block Lower +4. Tap Limit Block Lower cannot be higher than Tap Limit Block Raise –4). For all other controls, Block Raise is adjustable from 16 to –12 Raise with a factory setting of 16 Raise, and Block Lower is adjustable from 12 to –16 Lower with a factory setting of 16 Lower. Both have 1 step increments.

### Miscellaneous

**LDC-Z** – Adjustable from 0 V to 24 V in 1 V increments with a factory setting 0 V.

**Output Pulse Width** – Adjustable from 0.2 seconds to 12 seconds in 0.1 second increments with a factory setting of 1.5 second. C When the output is set to pulse and the control is calling for Raise/Lower (and no non-sequential or counter input is applied), an output will turn on for the preprogrammed time, and then turn off for 0.5 seconds, plus the intertap time delay. A square wave is generated on the output.



**Control Setup/Configuration**

The **Configuration** submenu item displays the **Configuration** Dialog Screen. The **Configuration** screen includes the Control Identification Number, the Comm Address, and User Lines #1 and #2 information. The configuration information displayed is default values if no TapTalk® file is open, from the control, or from an open TapTalk file. Elements of the Configuration screen are described on the following page.

The **Configuration** screen commands include:

- **Read from Control** – This command is available to read configuration settings from the target control when the Setpoints screen is selected to “Read From File”. When this command is selected, the button will change to “Connected to Control.”
- **Write to Control** – This command writes the values displayed/modified on the screen to the control.

- **Update File/Update Default** – If an existing file is open, **Update File** will write the values to the file. If a new file with default values is open, **Update Default** will update the values in RAM to be saved later.
- **Read from File/Read Default Config** – If a file is open, **Read from File** reads the values from the open file. When no new file is open, **Read Default Config** reads the default values from RAM.
- **Undo/Reload** – This command reloads configuration settings from either the control or TapTalk file (whichever is selected) prior to any **Write to Control** or **Write to File** command.

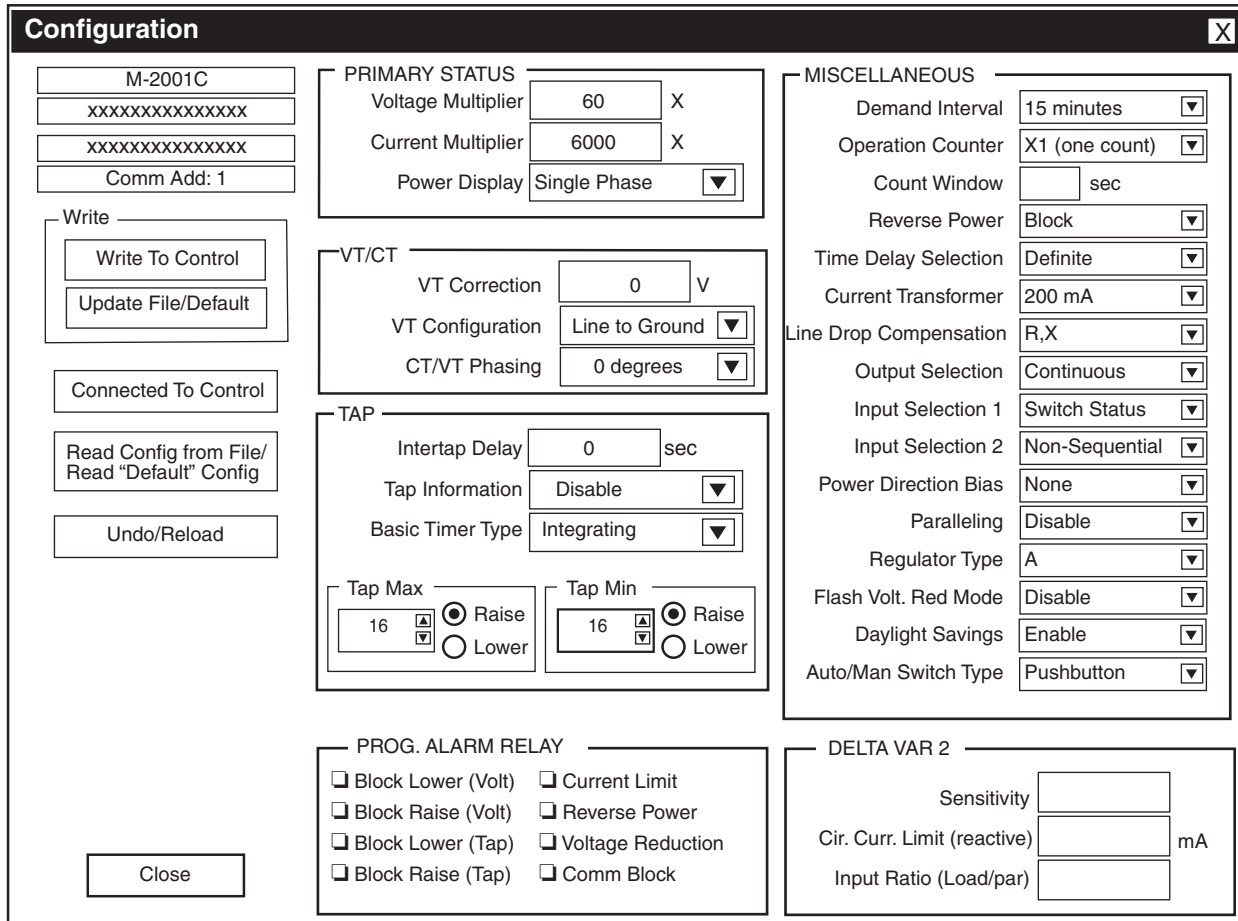

Figure 9-18 Configuration Dialog Screen

## Configuration

### Primary Status

**Voltage Multiplier** – Adjustable from 0.1 to 3260 in 0.1 increments with a factory setting of 60. User selection must include knowledge of VT ratio, sensing VT-ratio correction and indication of either line-to-line or line-to-ground voltage.

**Current Multiplier** – Adjustable from 1 to 32600 in 1.0 increments with a factory setting of 6000. User selection must include knowledge of CT ratio, from primary rating to 0.2 A rating of control.

**Power Display** – Toggles between two modes of operation: **SINGLE PHASE**, based on measured inputs; and **THREE PHASE**, based on measured inputs and presumed balanced system. Factory setting is **SINGLE PHASE**.

### VT/CT

**VT Correction** – Adjustable from –15 V to +15 V in 0.1 V increments with a factory setting of 0 V.

**VT Configuration** – Toggles between **LINE-TO-LINE** and **LINE-TO-GROUND** with a factory setting of **LINE-TO-GROUND**.

**CT/VT Phasing** – Adjustable from 0° to 330° in 30° increments with a factory setting of 0°.

### Tap

**InterTap Delay** – Adjustable from 0 to 60 seconds in 1.0 second increments with a factory setting of 0 seconds.

**Tap Information** – Toggles between two modes of operation: **DISABLED**, to disable all tap position-related functions and **REG. INTERNAL**, to use “keep track” tap position knowledge.

**Basic Timer Type** – Toggle between **INTEGRATE** (factory setting) or **INSTANT RESET**.

**Tap Max/Tap Min** – **Tap Max** is adjustable from 0 to 33R, and **Tap Min** is adjustable from 33L to 29R, both in 1 step increments. Note that **Tap Max** must be 4 taps greater than **Tap Min** (–33 to +29).

## PROGRAMMABLE ALARM RELAY

### Configuration

This feature is not available on the M-2001C (BASE-R) and will be grayed out in the display.

### Miscellaneous

**Demand Interval** – Toggles between 15, 30 and 60 minute intervals with a factory setting of 15 minutes. The time interval is that amount of time it takes for a thermal meter to indicate 90% of a change of load.

**Operation Counter** – Selects the contact operation sequence that will cause the software counter to increment by one. Open/close/open (X1), open/close or close/open contact operation (X2). The count window mode registers any activity as a valid input within the count window time setting. Factory setting of X1.

**Count Window** – Operation count will increment by only one count during a set time period or “Count Window”. This is true no matter how many counter inputs occur during the count window time period. After a counter input is accepted, the count window timer begins and another count won't be accepted until the count window time period expires. The count window time period can be set from 0.5 to 10.0 seconds.

**Reverse Power** – Toggles between four modes of operation: **BLOCK**, to inhibit automatic tapchange operation; **IGNORE**, to continue unit action as though forward power flow continued to exist; **REG REVERSE**, to detect a reverse power condition and regulate according to reverse power settings; **NEUTRAL**, to detect a reverse power operation and drive tap position to neutral and then stop. The factory setting is **BLOCK**.

**Timer Delay Selection** – Toggle between two modes of operation: **DEFINITE** (factory setting) and **INVERSE**.

**Current Transformer** – Toggle between three modes of operation: 200 mA (factory setting), 1 A and 5 A.

**Line Drop Compensation** – Toggle between two modes of operation: R, X (factory setting), and Z.

**Output Selection** – Toggle between two modes of operation: **CONTINUOUS** (factory setting) and **PULSE**.

**Input Selection 1** – Toggle between two modes of operation: **Seal-in Input** and **Switch Status** (factory setting).

**Input Selection 2** – This feature is not available on the M-2001C (BASE-R) and will be grayed out in the display.

**Power Direction Bias** – The Power Direction Bias Configuration feature includes three settings to determine how the control will switch between forward and reverse power operation. The three settings are **None**, **Forward**, and **Reverse**.

**Paralleling** – This feature is not available on the M-2001C (BASE-R) and will be grayed out in the display.

**Regulator Type** – Allows the regulator type to be selected as Type A or B for correct source voltage calculation. Factory setting is Type **A**.

**Flash Voltage Reduction Mode** – Allows the flashing voltage reduction status screen to be enabled or disabled. Enabling this function may shorten the life of the display screen.

**Daylight Savings** – Allows the user to enable or disable the daylight savings feature in the control.

**Auto/Man Switch Type** – Allows the user to set the function of the switch.

#### **Delta Var 2**

**Sensitivity** – This feature is not available on the M-2001C (BASE-R) and will be grayed out in the display.

**Cir.Curr. Limit Reactive** – This feature is not available on the M-2001C (BASE-R) and will be grayed out in the display.

**Input Ratio (Load/par)** – This feature is not available on the M-2001C (BASE-R) and will be grayed out in the display.

#### **Control Setup/DNP Configuration**

DNP Configuration is not available with the M-2001C (BASE-R).

**Control Monitor**



<b>Control Monitor</b>
Status
Demand Metering
Energy Metering
Harmonic Analysis
Tap Statistics

The **Control Monitor** toolbar item provides the user with the means to display the control's **Status**, **Demand Metering** and **Energy Metering** screens. The screens include the Control Identification Number, the Comm Address, and User Lines #1 and #2 information. These screens and the data that is displayed are available only when communication is established between the control and the PC.

**Control Monitor/Status**

The **Status** submenu item displays the **Status** Screen. Values displayed are updated based on the monitoring setting in the timers section, and also depending on communication system capabilities.

Each Status screen will also display Communication Status Indicator icons:

-  Unit is connected.
-  Communication lost, attempting to reconnect (time allowed for reconnect attempt is set in the Timers dialog box.)
-  Reconnect failed.

**Status** X

M-2001C	Comm Add: 1
xxxxxxxxxxxxxxxx	xxxxxxxxxxxxxxxx
Control Date: <input type="text" value="Mon/Jan/14/02"/>	Control Time: <input type="text" value="09:38:48"/>

<p style="text-align: center; margin: 0;">PRIMARY STATUS (Single Phase)</p> <table style="width: 100%; border-collapse: collapse;"> <tr><td>Voltage</td><td><input type="text" value="7.19"/></td><td>KV</td></tr> <tr><td>Current</td><td><input type="text" value="0"/></td><td>Amps</td></tr> <tr><td>Watts</td><td><input type="text" value="0"/></td><td>MW</td></tr> <tr><td>VAr</td><td><input type="text" value="0"/></td><td>MVAr</td></tr> <tr><td>VA</td><td><input type="text" value="0"/></td><td>MVA</td></tr> </table>	Voltage	<input type="text" value="7.19"/>	KV	Current	<input type="text" value="0"/>	Amps	Watts	<input type="text" value="0"/>	MW	VAr	<input type="text" value="0"/>	MVAr	VA	<input type="text" value="0"/>	MVA	<p style="text-align: center; margin: 0;">SECONDARY STATUS</p> <table style="width: 100%; border-collapse: collapse;"> <tr><td>Local Voltage</td><td><input type="text" value="119.5"/></td><td>V</td></tr> <tr><td>Source Voltage</td><td><input type="text" value="119.5"/></td><td>V</td></tr> <tr><td>Load Current</td><td><input type="text" value="0"/></td><td>mA</td></tr> <tr><td>Comp. Volts</td><td><input type="text" value="119.5"/></td><td>V</td></tr> <tr><td>Circulating Current</td><td><input type="text" value="0"/></td><td>mA</td></tr> <tr><td>Power Factor</td><td><input type="text" value="0"/></td><td></td></tr> </table>	Local Voltage	<input type="text" value="119.5"/>	V	Source Voltage	<input type="text" value="119.5"/>	V	Load Current	<input type="text" value="0"/>	mA	Comp. Volts	<input type="text" value="119.5"/>	V	Circulating Current	<input type="text" value="0"/>	mA	Power Factor	<input type="text" value="0"/>	
Voltage	<input type="text" value="7.19"/>	KV																																
Current	<input type="text" value="0"/>	Amps																																
Watts	<input type="text" value="0"/>	MW																																
VAr	<input type="text" value="0"/>	MVAr																																
VA	<input type="text" value="0"/>	MVA																																
Local Voltage	<input type="text" value="119.5"/>	V																																
Source Voltage	<input type="text" value="119.5"/>	V																																
Load Current	<input type="text" value="0"/>	mA																																
Comp. Volts	<input type="text" value="119.5"/>	V																																
Circulating Current	<input type="text" value="0"/>	mA																																
Power Factor	<input type="text" value="0"/>																																	
<p style="text-align: center; margin: 0;">TIMERS/COUNTERS</p> <table style="width: 100%; border-collapse: collapse;"> <tr><td>Raise Timer</td><td><input type="text" value="0"/></td><td>sec</td></tr> <tr><td>Lower Timer</td><td><input type="text" value="0"/></td><td>sec</td></tr> <tr><td>Intertap Timer</td><td><input type="text" value="0"/></td><td>sec</td></tr> <tr><td>Operations Counter</td><td><input type="text" value="1"/></td><td></td></tr> </table>	Raise Timer	<input type="text" value="0"/>	sec	Lower Timer	<input type="text" value="0"/>	sec	Intertap Timer	<input type="text" value="0"/>	sec	Operations Counter	<input type="text" value="1"/>		<p style="text-align: center; margin: 0;">ALARM BLOCKS STATUS</p> <table style="width: 100%; border-collapse: collapse;"> <tr><td>Lower (Tap)</td><td><input type="text" value="OFF"/></td><td>Comm Block</td><td><input type="text" value="OFF"/></td></tr> <tr><td>Raise(Tap)</td><td><input type="text" value="OFF"/></td><td>Current Limit</td><td><input type="text" value="OFF"/></td></tr> <tr><td>Lower(Volt)</td><td><input type="text" value="OFF"/></td><td>Reverse Power</td><td><input type="text" value="OFF"/></td></tr> <tr><td>Raise (Volt)</td><td><input type="text" value="OFF"/></td><td>V Red in Effect</td><td><input type="text" value="OFF"/></td></tr> </table>	Lower (Tap)	<input type="text" value="OFF"/>	Comm Block	<input type="text" value="OFF"/>	Raise(Tap)	<input type="text" value="OFF"/>	Current Limit	<input type="text" value="OFF"/>	Lower(Volt)	<input type="text" value="OFF"/>	Reverse Power	<input type="text" value="OFF"/>	Raise (Volt)	<input type="text" value="OFF"/>	V Red in Effect	<input type="text" value="OFF"/>					
Raise Timer	<input type="text" value="0"/>	sec																																
Lower Timer	<input type="text" value="0"/>	sec																																
Intertap Timer	<input type="text" value="0"/>	sec																																
Operations Counter	<input type="text" value="1"/>																																	
Lower (Tap)	<input type="text" value="OFF"/>	Comm Block	<input type="text" value="OFF"/>																															
Raise(Tap)	<input type="text" value="OFF"/>	Current Limit	<input type="text" value="OFF"/>																															
Lower(Volt)	<input type="text" value="OFF"/>	Reverse Power	<input type="text" value="OFF"/>																															
Raise (Volt)	<input type="text" value="OFF"/>	V Red in Effect	<input type="text" value="OFF"/>																															
<p style="text-align: center; margin: 0;">MISCELLANEOUS</p> <table style="width: 100%; border-collapse: collapse;"> <tr><td>Tap Position</td><td><input type="text" value="Disable"/></td></tr> <tr><td>Band Status</td><td><input type="text" value="OK"/></td></tr> <tr><td>Power Direction</td><td><input type="text" value="Forward"/></td></tr> <tr><td>Operation Direction</td><td><input type="text" value="Forward"/></td></tr> <tr><td>Voltage Reduction in Effect</td><td><input type="text" value="OFF"/></td></tr> <tr><td>Voltage Reduction Steps</td><td><input type="text" value="No Red"/></td></tr> </table>	Tap Position	<input type="text" value="Disable"/>	Band Status	<input type="text" value="OK"/>	Power Direction	<input type="text" value="Forward"/>	Operation Direction	<input type="text" value="Forward"/>	Voltage Reduction in Effect	<input type="text" value="OFF"/>	Voltage Reduction Steps	<input type="text" value="No Red"/>	<p style="text-align: center; margin: 0;">INPUT</p> <table style="width: 100%; border-collapse: collapse;"> <tr><td>Counter</td><td><input type="text" value="OFF"/></td><td>Non-Sequential</td><td><input type="text" value="OFF"/></td></tr> <tr><td>Neutral Tap</td><td><input type="text" value="OFF"/></td><td>V. Reduction 1</td><td><input type="text" value="OFF"/></td></tr> <tr><td>Switch Status</td><td><input type="text" value="OFF"/></td><td>V. Reduction 2</td><td><input type="text" value="OFF"/></td></tr> </table> <p style="text-align: center; margin: 0;">OUTPUT</p> <table style="width: 100%; border-collapse: collapse;"> <tr><td>Raise</td><td><input type="text" value="OFF"/></td><td>Lower</td><td><input type="text" value="OFF"/></td></tr> <tr><td>Seal In</td><td><input type="text" value="OFF"/></td><td>Alarm</td><td><input type="text" value="OFF"/></td></tr> </table>	Counter	<input type="text" value="OFF"/>	Non-Sequential	<input type="text" value="OFF"/>	Neutral Tap	<input type="text" value="OFF"/>	V. Reduction 1	<input type="text" value="OFF"/>	Switch Status	<input type="text" value="OFF"/>	V. Reduction 2	<input type="text" value="OFF"/>	Raise	<input type="text" value="OFF"/>	Lower	<input type="text" value="OFF"/>	Seal In	<input type="text" value="OFF"/>	Alarm	<input type="text" value="OFF"/>	
Tap Position	<input type="text" value="Disable"/>																																	
Band Status	<input type="text" value="OK"/>																																	
Power Direction	<input type="text" value="Forward"/>																																	
Operation Direction	<input type="text" value="Forward"/>																																	
Voltage Reduction in Effect	<input type="text" value="OFF"/>																																	
Voltage Reduction Steps	<input type="text" value="No Red"/>																																	
Counter	<input type="text" value="OFF"/>	Non-Sequential	<input type="text" value="OFF"/>																															
Neutral Tap	<input type="text" value="OFF"/>	V. Reduction 1	<input type="text" value="OFF"/>																															
Switch Status	<input type="text" value="OFF"/>	V. Reduction 2	<input type="text" value="OFF"/>																															
Raise	<input type="text" value="OFF"/>	Lower	<input type="text" value="OFF"/>																															
Seal In	<input type="text" value="OFF"/>	Alarm	<input type="text" value="OFF"/>																															

Comm Status: 

Figure 9-19 Status Screen

### Primary Status (single or three phase)

**Local Voltage** – Displays the calculated primary voltage based on the user-selected voltage multiplier, VT corrections, and measured secondary voltage.

**Primary Current** – Displays the calculated primary current based on the user-selected current multiplier, and measured secondary current.

**Primary Watts** – Displays the calculated primary quantity based on the user-selected voltage and current multipliers; VT configuration (line-to-line or line-to-ground), single-phase or three-phase, and measured secondary voltage and current.

**Primary VAR** – Displays the calculated primary quantity based on the user-selected voltage and current multipliers, VT configuration (line-to-line or line-to-ground), single-phase or three-phase, and measured secondary voltage and current.

**Primary VA** – Displays the calculated primary quantity based on the user-selected voltage and current multipliers, VT configuration (line-to-line or line-to-ground), single-phase or three-phase, and measured secondary voltage and current.

### Timers/Counters

**Raise Timer** – Displays the integrated out-of-band time for a voltage excursion greater than the upper band limit up to the value of the time delay setpoint.

**Lower Timer** – Displays the integrated out-of-band time for a voltage excursion less than the lower band limit up to the value of the time delay setpoint.

**Intertap Timer** – In the sequential mode of operation, displays the integrated out-of-band time for a voltage excursion and the subsequent tap change. Adjustable from 0 to 60 seconds, in 1.0 second increments, with a factory setting of 0 seconds.

**Operations Counter** – Records the number of raise and lower operations. The operation counter will advance by one or two counts, as set by the user, for each open-close-open contact operations. This counter is not resettable.

### Miscellaneous

**Tap Position** – Displays the tap position of the tapchanger by the internal “keep track” procedure or external tap position sensor. Recognizes tapchanges commanded via manual, automatic or external (SCADA) means.

**Band Status** – Indicates one of three conditions: **High**, when voltage is out of band high, **Low** when voltage is out of band low, and **OK** when voltage is within band.

**Power Direction** – Indicates one of two power directions: **Forward** (forward power condition) and **Reverse** (reverse power condition).

**Operation Direction** – Indicates one of two modes of operation: **Forward**, indicating forward power regulation, due to either actual forward power flow, an Ignore configuration forcing unit action as though forward power flow exists when a reverse power flow is detected, or a Block configuration inhibiting automatic tapchange operation when reverse power flow is detected, or **Reverse**, detecting a reverse power condition, while control is configured for reverse regulation.

**Voltage Reduction In Effect** – Indicates voltage reduction (any step) is invoked.

**Voltage Reduction Steps – No Reduction** indicates voltage reduction is not active, blocked either by non-sequential input, a reverse power condition, or by communicated command. Steps 1, 2, and 3 indicate that voltage reduction is in effect for the stated step value.

### Secondary Status

**Local Voltage** – Displays the real-time measured value of voltage at the regulator or transformer and includes any corrections made using the user-selected VT correction voltage.

**Source Voltage** – Displays the real-time calculated source voltage and includes any corrections made using the user-selected VT correction voltage.

**Load Current** – Displays the real-time measured value of current.

**Compensate Volts** – Displays the calculated voltage at the “load center”.

**Circulating Current** – This feature is not available on the M-2001C (BASE-R) and will be grayed out in the display.

**Power Factor** – Displays the real-time calculated value of power factor.

**Alarm Blocks Status** – This feature is not available on the M-2001C (BASE-R) and will be grayed out in the display.

**Lower (Tap)** – This feature is not available on the M-2001C (BASE-R) and will be grayed out in the display.

**Raise (Tap)** – This feature is not available on the M-2001C (BASE-R) and will be grayed out in the display.

**Lower (Volt)** – This feature is not available on the M-2001C (BASE-R) and will be grayed out in the display.

**Raise (Volt)** – This feature is not available on the M-2001C (BASE-R) and will be grayed out in the display.

**Comm Block** – This feature is not available on the M-2001C (BASE-R) and will be grayed out in the display.

**Current Limit** – This feature is not available on the M-2001C (BASE-R) and will be grayed out in the display.

**Reverse Power** – This feature is not available on the M-2001C (BASE-R) and will be grayed out in the display.

**V. Red in Effect** – This feature is not available on the M-2001C (BASE-R) and will be grayed out in the display.

## Input

**Counter** – Indicates operation counter contact input is closed.

**Neutral Tap** – Indicates neutral position contact input is closed.

**Switch Status** – Provides the user feedback on the position of the Auto/Off/Manual switch. When the M-2001C (BASE-R) is configured for a switch status input, the switch status is read using the seal-in input on the control.

**Non-Sequential** – This feature is not available on the M-2001C (BASE-R) and will be grayed out in the display.

**Volt Reduction 1** – Indicates Step 1 voltage reduction contact output is closed.

**Volt Reduction 2** – Indicates Step 2 voltage reduction contact output is closed.

## Output

**Raise** – Indicates Raise output is active.

**Lower** – Indicates lower output is active.

**Seal-In** – Indicates seal-in feature is active, if the control is used with a Cooper (McGraw-Edison) regulator.

**Alarm** – This feature is not available on the M-2001C (BASE-R) and will be grayed out in the display.

**Control Monitor/Demand Metering**

The **Demand Metering** submenu item displays the **Demand Metering** screen. Real-time demand metering information can be monitored from an addressed control.

**Control Date** and **Control Time** displays current time and date of the addressed control.

**Demand Metering** parameters are described on the following page.

**Demand Metering**
X

M-2001C	Comm Address: 1
xxxxxxxxxxxxxxxx	xxxxxxxxxxxxxxxx

Control Date: Mon/Jan/14/02

Control Time: 09:40:02

DEMAND PRESENT (Single Phase)

Demand Interval	15	min	Primary Curr.	0	Amps	Primary VAR	0	MVAR
Local Volt (32s AVG)	120.4	V	Primary Watts	0	MW	Primary VA	0	MVA

DEMAND HISTORY (Single Phase)

Parameter	Date	Time	Reset
Local Volt (Min)    116.9    V	Jan/08/02	15:25:07	Reset
Local Volt (Max)    123.6    V	Jan/08/02	09:08:56	Reset
Primary Current (Max)    0    Amps	Jan/08/02	11:48:57	Reset
Primary Watts (Max)    0    MW	Jan/08/02	11:48:53	Reset
Primary VAR (Max)    0    MVAR	Jan/08/02	11:48:59	Reset
Primary VA (Max)    0    MVA	Jan/08/02	09:22:57	Reset
Power Fact. (@Max VA)    -0.76    Lag	Jan/08/02	09:22:57	Reset

Demand Metering Master Reset

Draghand Lower	16	Low			Resettable Op Cnt.	0	Reset
Draghand Raise	16	Raise	Reset	Operation Counter	1000	Set	

Close

Comm Status:

Figure 9-20 Demand Metering Dialog

## Demand Metering

### Demand Present (Single Phase)

**Demand Interval** – Indicates the time interval required for a thermal meter to indicate 90% of a change of load, adjustable from 15, 30, and 60 minutes.

**Local Volt** – Displays the real-time measured value of voltage at the regulator or transformer. This value continuously averaged over consecutive 32-second intervals.

**Primary Curr** – Displays the calculated primary demand current based on the user-selected current multiplier and measured secondary current.

**Primary Watts** – Displays the demand value based on the user-selected voltage and current multipliers; VT configuration (line-to-line or line-to-ground), single-phase or three-phase, and measured secondary voltage and current.

**Primary VAr** – Displays the demand value based on the user-selected voltage and current multipliers, VT configuration (line-to-line or line-to-ground), single-phase or three-phase, and measured secondary voltage and current.

**Primary VA** – Displays the demand value based on the user-selected voltage and current multipliers, VT configuration (line-to-line or line-to-ground), single-phase or three-phase, and measured secondary voltage and current.

### Demand History (Single Phase or Three Phase)

–All demand history values include the date and time at which each occurred. A draghand value is the maximum or minimum value of a measured quantity recorded since the last reset.

**Local Volt (Min)** – Displays minimum local voltage at the regulator or transformer. This value continuously averaged over consecutive 32-second intervals.

**Local Volt (Max)** – Displays draghand maximum local voltage at the regulator or transformer. This value continuously averaged over consecutive 32-second intervals.

**Primary Current (Max)** – Displays draghand maximum primary current.

**Primary Watts (Max)** – Displays draghand maximum primary watts.

**Primary VAr (Max)** – Displays draghand maximum primary VAr.

**Primary VA (Max)** – Displays draghand maximum primary VA. Resets automatically when Power Factor at (Max) VA value, below, is reset.

**Power Factor at (Max) VA** – Displays draghand power factor at time of maximum VA.

## Miscellaneous

**Master Reset** – Resets all Demand History date and time stamps and values.

**Draghand Lower** – Displays the lowest tap since last reset.

**Draghand Raise** – Displays the highest tap since last reset.

**Resettable Op Cnt** – Displays the number of operations since the last reset. Can be set by the user.

**Operation Counter** – Displays the number of operations.



**Control Monitor/Energy Metering**

■ **NOTE:** M-2001 firmware version must be V-07.03.20 or later.

The **Energy Metering** submenu item displays the **Energy Metering** screen. This feature enables the user to review real-time and historical demand metering information. The screen includes the current date and time, Watt Hour (Single Phase or Three

Phase) forward and reverse, and VAr Hour (Single Phase or Three Phase) forward and reverse metered values.

Each element can be reset individually by selecting **Reset** for the desired parameter. When a **Reset** command is issued, the metered value is reset to zero and the time and date are updated.

Energy Metering		X	
M-2001C		Comm Add: 1	
xxxxxxxxxxxxxxxx		xxxxxxxxxxxxxxxx	
Control Date	Wed/Jul/14/04	Control Time	09:22:45
<b>Watt Hour (Single Phase)</b>		<b>Var Hour (Single Phase)</b>	
<b>Forward</b>		<b>Forward</b>	
Watt Hours	51.25 MWHrs	VAr Hours	44.00 MVARHrs
Time	09:41:28	Time	09:41:28
Date	Jul/07/04	Date	Jul/07/04
Reset		Reset	
<b>Reverse</b>		<b>Reverse</b>	
Watt Hours	23.00 KWHrs	VAr Hours	7.76 MVARHrs
Time	09:41:28	Time	09:41:28
Date	Jul/07/04	Date	Jul/07/04
Reset		Reset	
Close		Comm Status: 	

Figure 9-21 Energy Metering Screen

**Control Monitoring/Harmonic Analysis**

■ **NOTE:** M-2001 firmware version must be V-07.09.XX or later .

The **Harmonic Analysis** submenu item displays the **Harmonic Analysis** screen. This feature enables the user to review voltage and current harmonics as a function of % fundamental or RMS. When this feature is selected, TapTalk acquires 4 cycles of data and calculates the harmonic spectrum for each

cycle, and then displays the average of the four cycles of data for each harmonic. The user can select and view detailed information for each harmonic, save the data to file (text file) for viewing at a later time, or acquire a more current data set for display. When “Show Graph As RMS” is selected, the graph displays RMS values in Volts and mAmps.

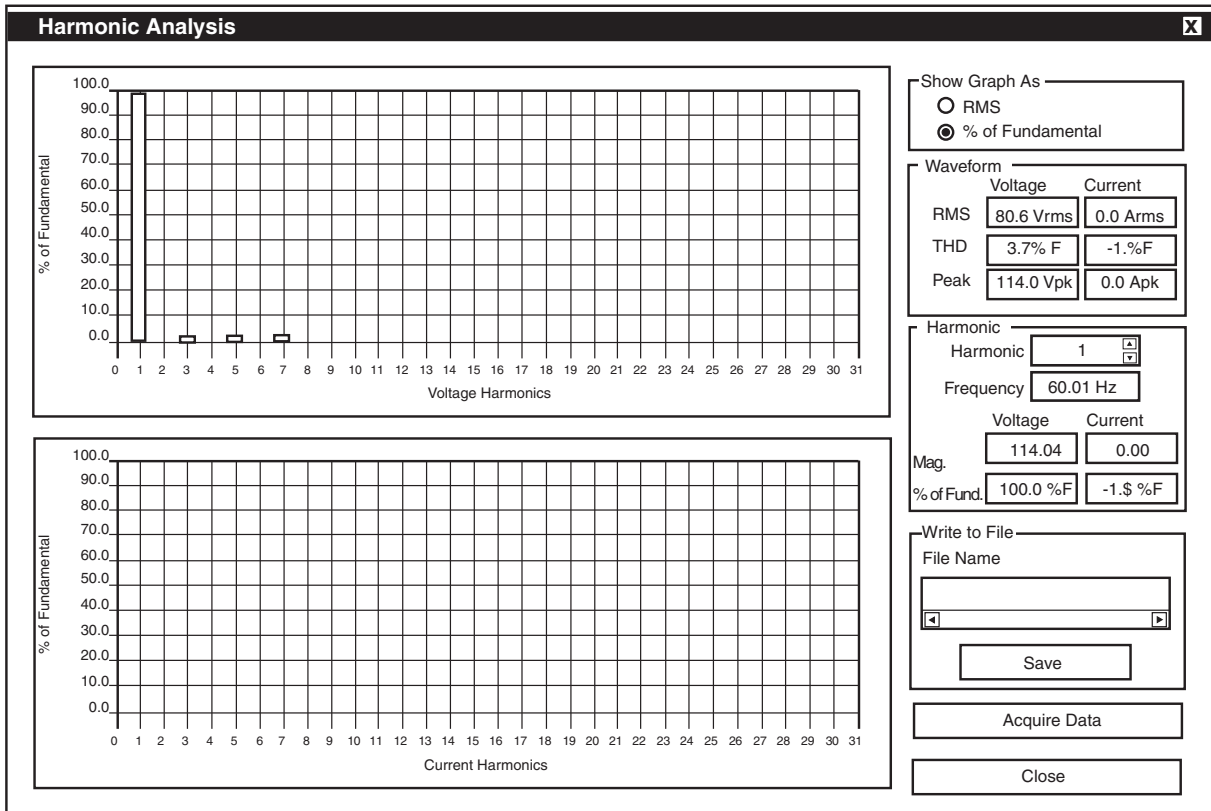

Figure 9-22 Harmonic Analysis Dialog Screen

**Control Monitoring/Tap Changed Statistic**

▲ **CAUTION:** Selecting RESET COUNTER will permanently delete all tap change statistics.

■ **NOTE:** M-2001 firmware version must be V-07.09.XX or later .

The **Tap Changes Statistic** submenu item displays a statistical representation of the Tapchanger operation. The cumulative (since last visit) number of tapchanges for each tap position is displayed both graphically and numerically. Selecting **REFRESH** updates tap statistical data. Selecting **RESET COUNTER** resets all tap statistic counters to zero.

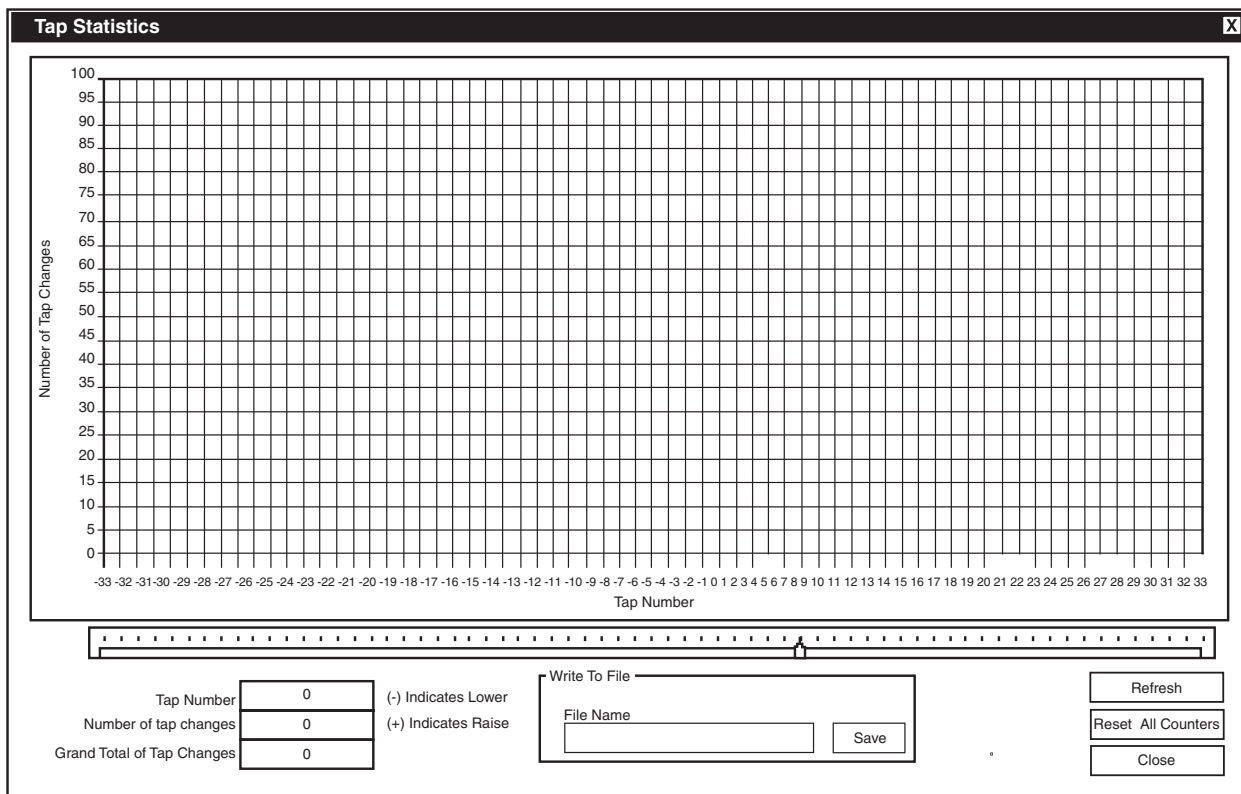

Figure 9-23 Tap Changes Statistic Screen

## Utilities

Utilities
Remote Control
Data Logging ▶
Control Information
Set Control Date/Time
Set User Lines
Set New User Passwords

The **Utilities** menu includes the **Remote Control**, **Data Logging**, **Control Information**, **Set Control Date and Time**, **Set User Lines**, and **Set New User Passwords** commands.

### Remote Control

▲ **CAUTION:** This feature should be used with extreme caution.

The **Remote Control** menu item displays the **Remote Control** screen. The **To Current Comm Address** selection enables the user to remotely raise or lower the tap position as well as apply voltage reduction to an individual control. The **Broadcast** selection allows the user to remotely apply voltage reduction to one or more controls. Also included is the **Tap Calibrate** command which enables the user to initialize the tap position for a transformer or regulator when the control is installed. Tap calibration is required for keeping accurate tap positions when using a current loop or the “keep track” method.

### Remote Control and Automatic Mode Blocking

The Automatic Mode Blocking feature using Remote Control will cause the control to respond in a predefined manner to either a serial communication interruption or power loss to the control. The Control will respond as follows:

- If Automatic control has been Blocked using TapTalk®, then Automatic Control will remain Blocked if serial communication is disrupted or lost.
- If Automatic Control has been Blocked using TapTalk, and the **Save Comm. Blk** feature is **Enabled**, then the Automatic Control Block will be reinstated at power up.
- If Automatic Control has been Blocked using TapTalk, and the **Save Comm. Blk** feature is **Disabled**, then the Automatic Control Block will not be reinstated at power up.

### Restoring Automatic Operation (Local)

Automatic operation can be restored from the front panel by removing the “Block Auto Control via Communication” through TapTalk or by performing the following:

1. From the control front panel pushbuttons change the **Comm Block Auto** setting in the **Configuration** menu to **DONT SAVE**.
2. Remove power to the control, then reapply power to the control. Automatic operation will then be restored.

**Remote Control**
✕

M-2001C

xxxxxxxxxxxxxxxx

Comm Add: 1

xxxxxxxxxxxxxxxx

To Current Control Address

Broadcast

**Tap Control**

Tap Position Disable

Local Voltage 120.5 Volt

---

**Tap Raise**

Block Raise Inactive

Raise 1 Tap

---

**Tap Lower**

Block Lower Inactive

Lower 1 Tap

**Voltage Reduction**

Step 1  
  Step 2  
  Step 3

Clear

---

**Block Auto Control via Communication**

BLOCK
UNBLOCK

Save Comm. Block at Power Off

Enable  
  Disable

---

**Tap Calibrate**

Set to MATCH reading of actual tap position

0 Neutral
Set

Close

Comm Status: ↻

Figure 9-24 Remote Control Screen

### Remote Control

▲ **CAUTION:** This feature should be used with extreme caution.

The **Remote Control** feature enables the user to remotely raise or lower tap position, as well as apply voltage reduction when the control is in Automatic.

### Remote Voltage Reduction

**Step #1** – Initiates first step voltage reduction command for addressed control.

**Step #2** – Initiates second step voltage reduction command for addressed control.

**Step #3** – Initiates third step voltage reduction command for addressed control.

**Clear** – Removes remote voltage reduction commands for addressed control.

### Remote Tap Control

**Lower 1 Tap** – Initiates remote Lower in 1 step increments. Limited by tap Block Lower setpoint and tap position limit settings.

**Raise 1 Tap** – Initiates remote Raise in 1 step increments. Limited by tap Block Raise setpoint and tap position limit settings.

### Block Auto Control via Communication

**Block** – Blocks automatic operation of the addressed control.

**Unblock** – Initiates automatic operation of the addressed control.

**Save Comm. Block at Power Off** – Allows the state of the “Block Auto Operation” communication command to be saved or not saved when power has been lost.

**Exit** – Returns to the TapTalk main window. Exiting does not cancel blocking or voltage reduction. *Automatic operation of the control is disabled until the **Unblock** command is chosen.*

### Broadcast Control

▲ **CAUTION:** This feature should be used with extreme caution.

The **Broadcast Control** feature enables the user to remotely apply voltage reduction and/or Block (Unblock) Automatic Control to one or more controls.

### Remote Voltage Reduction

**Step #1** – Initiates first step-voltage reduction command for all controls on the communication network.

**Step #2** – Initiates second step-voltage reduction command for all controls on the communication network.

**Step #3** – Initiates third step-voltage reduction command for all controls on the communication network.

**Clear** – Removes remote voltage reduction commands for all controls on the communication network.

### Block Auto Control via Communication

**Block** – Blocks automatic operation of all controls on the communication network.

**Unblock** – Initiates automatic operation of all controls on the communication network.

**Save Comm. Block at Power Off** – Allows the state of the “Block Auto Operation” communication command to be saved or not saved when power has been lost.

### Tap Calibrate

The Tap Calibrate feature enables the user to initialize the tap position for a transformer or regulator when the control is installed. Tap calibration is required for keeping accurate tap positions when using a current loop or the “Keep Track” method.

**Tap Position** – Sets actual tap position.

**Raise/Lower** – Sets actual tap direction.

**Set** – Writes the currently displayed tap position and direction to the addressed control.

**Exit** – Returns to the TapTalk main window. Exiting does not cancel blocking or voltage reduction. *Automatic operation of the control is disabled until the **Unblock** command is chosen.*

Utilities/Data Logging

**Data Logging**

**Control Setup and Download To PC**

The **Data Logging** toolbar item includes **Control Setup and Download** and **To PC** data logging features.

When connected to a M-2001C (BASE-R) control the **Data Logging** feature provides the user with the ability to initiate data logging of selectable control parameters to either the selected control for downloading at a later time or directly to a PC.

This feature allows the user to configure the parameters that the control will use to log data, and to download the logged data to a comma separated value (CSV) file or a TapPlot file. CSV files can be opened in a spreadsheet program such as Microsoft Excel™. TapPlot files can be viewed with TapPlot.

**Data Logging/Control Setup and Download**

This submenu item displays the **Data Logging Control Setup and Download** Dialog Screen.

The **Logging** section allows the user to select the parameters to be logged by the control. The number of parameters selected determines the **Max Time Available** duration that the control can store.

In the **Logging Timer** section, the **Sampling Period** allows the user to input the frequency in minutes at which the data will be logged. **Max Time Available** displays the amount of data that can be held in the circular memory block. This field will automatically update with any changes made in the **Sampling Period** or the **Data To Be Logged** section.

To erase the existing data and start logging new data, select **“Erase Existing Data and Start Logging Data to Control...”**

Once the **Data to be Logged** parameters are uploaded to the control by selecting **Erase Existing Data and Start Logging data to Control**, the control will log data to onboard memory. Logging will continue indefinitely until a new set of log parameters are uploaded, at which point all previously logged data will be cleared, and the control will begin logging data with the new parameters.

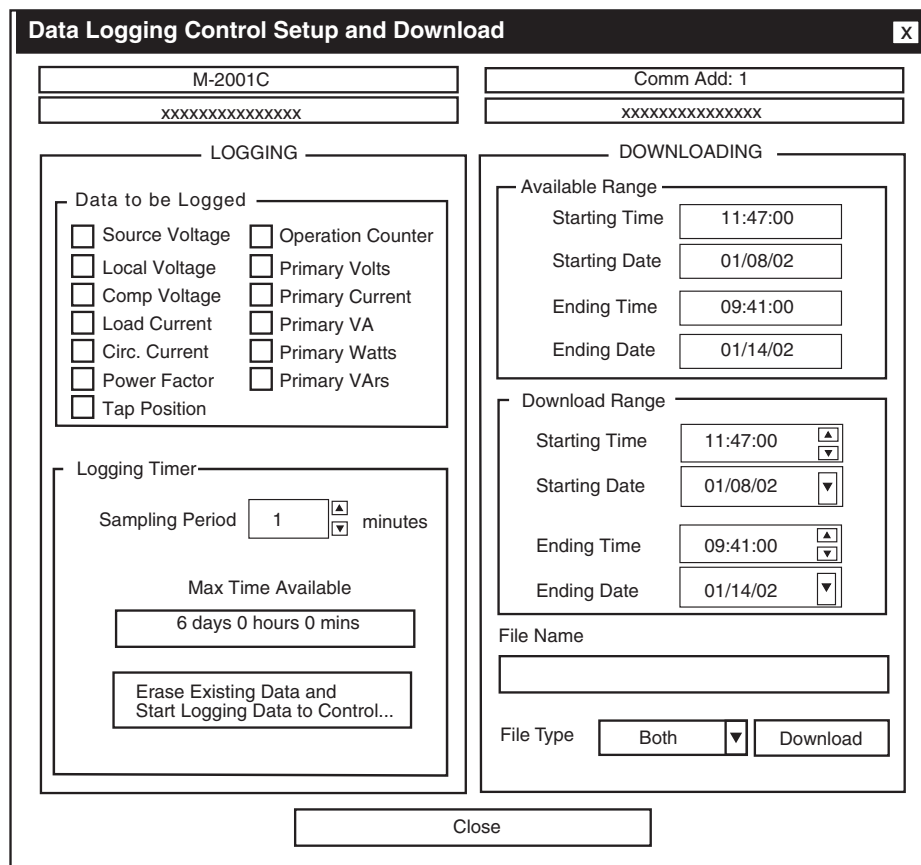

Figure 9-25 Data Logging to Control Dialog Screen

In the **Downloading** portion of the screen, the **Available Range** section will display the oldest and latest dates of the logged data. These dates will also initially appear in the **Download Range** section edit boxes, which indicate the start and end points for the data to be downloaded.

The **File Name** text box contains the name of the file to which the data will be downloaded. The **File Type** box also contains the selection which can be “.CSV”, “.TPF” or both. A “.CSV” file extension is required for these files so that they can be recognized and opened by Excel or Lotus123 compatible spreadsheet applications. A “.TPF” file extension allows the file to be read by TapPlot™. If an incorrect file extension or no extension is used, TapTalk® will prompt the user to have TapTalk apply a correct extension or cancel the operation. Files saved using duplicate file names will be overwritten without warning.

▲ **CAUTION:** Be sure to download your data before changing parameters. Once the **Start Logging to Control** button is selected, all previously logged data will be cleared (and will no longer be available for download), and the control will begin logging new data.

When **Download** is selected, all data selected in the Download Range section will be downloaded to the file displayed in the **File's Name** section. If the range chosen includes a large amount of data, the download may take up to 45 minutes (300 Kb).

If necessary edit the Download Range, then select **Download** to download the data from the selected range.

### Data Logging/To PC

The **To PC** submenu item displays the **Data Logging to PC** Dialog Screen ( Figure 9-26). The **To PC** feature enables the user to store selected parameter data for review at a later time. One or more of the parameters listed in the **Data To Be Logged** section can be selected for logging. The time displayed in the **Sampling Period** in the **Logging Options** section determines how frequently data samples are acquired, ranging from 1 minute to a maximum of 9999 minutes. The duration of sampling is further regulated by the **Sampling Duration** which restricts data logging to a maximum of 9999 hours or 9999 days. Uninterrupted communication with the control is required while data is being logged.

Data logging is initiated by selecting **Start Data Logging to PC**. The **Start Data Logging to PC** is replaced by **Stop Data Logging to PC** dialog to indicate data logging is active. Logging can be canceled either by choosing the **Stop Data Logging to PC** command or by interrupting communication.

The **Set File Name** selection allows the user to name the file to which data is saved. If the Suggested File Name feature is disabled, then a file name will be required to be entered with a default file extension of \*.CSV, (Comma Separated Values is the default for files with data logging information). If the Suggested File Name is enabled, then the file name will be determined by the settings from the Suggested File Name window with a filename extension of “.CSV”. If the user saves a file using a duplicate filename, the previously saved file will be overwritten without warning. The size of the file must not exceed available disk space. The file format “.CSV” can be opened by most spreadsheet applications, allowing the user to analyze the collected data.

Figure 9-26 Data Logging To PC Dialog Screen



**Utilities/Control Information**

The **Control Information** submenu item displays the **Control Information** Screen (Figure 9-27). The **Control Information** screen provides specific information about the addressed control. The **Control Information** screen includes the following:

- Beckwith Electric identification (model) number
- The addressed control’s serial number
- Control’s software version
- Mod Number
- Model of M-2001C
- The text currently displayed in the User Text Lines 1 and 2
- Control Address
- The Communication Channel status which reflects whether the correct communication password has been identified, “unlocking” the communication channel and allowing access to the control.

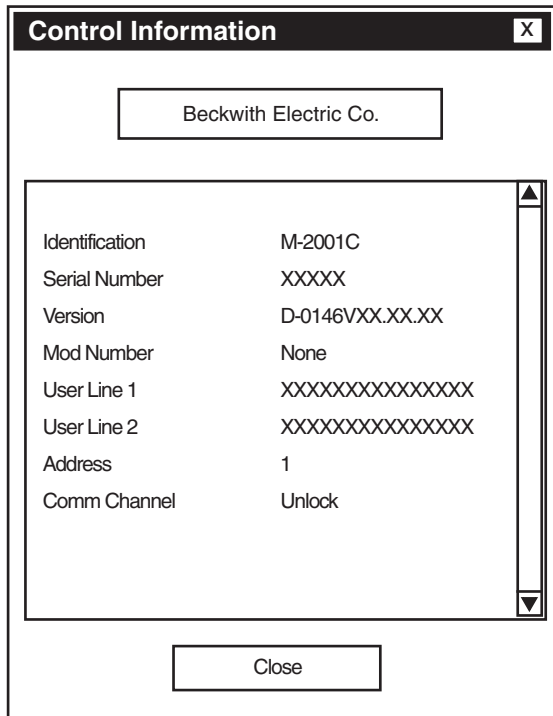

Figure 9-27 Control Information Screen

**Utilities/Set Control Date and Time**

The **Set Control Date and Time** submenu item enables the user to review the internal clocks for the PC, the addressed control, or all controls in the broadcast mode, as well as the last power-up for the addressed control.

To set control(s) time/date perform the following:

1. Select either **To Current Address** or **Broadcast**
2. Input the desired time/date, then select **Set**

To set control(s) time/date to match PC’s current time/date perform the following:

1. Select either **To Current Address** or **Broadcast**
2. Select **Set Control time to PC’s time**

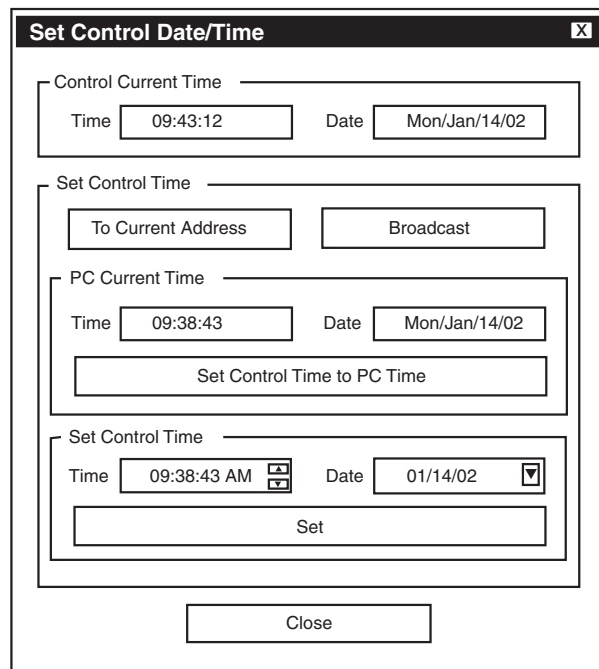

Figure 9-28 Set Control Date and Time Dialog Screen

When the time is set, a prompt will be displayed, asking if the user wants to reset Demand Metering, Energy Metering (if applicable), Drag Hands and Resettable OP Count.

**Utilities/Set User Lines**

The **Set User Lines** submenu item provides the user with the ability to review and change the user lines for the addressed control.

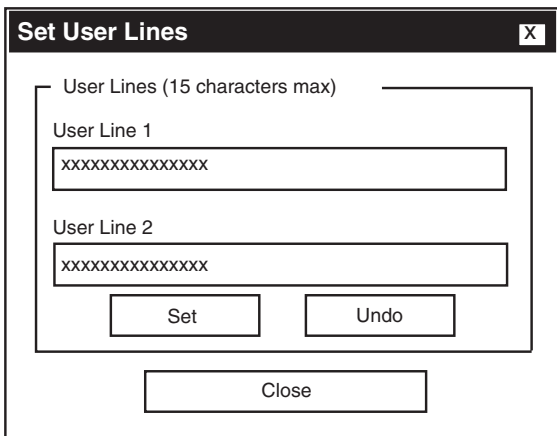

Figure 9-29 Set User Lines Dialog Screen

**Utilities/Set New User Passwords**

The **Set New Passwords** submenu item displays the **New Passwords Setup** Dialog Screen.

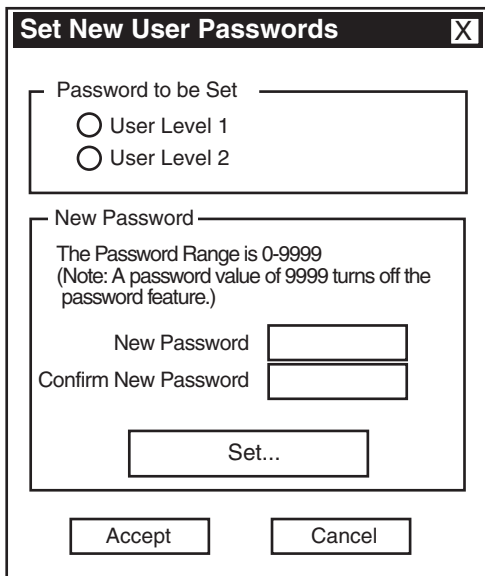

Figure 9-30 New Passwords Setup Dialog Screen

TapTalk® User Level 1 and User Level 2 passwords are unique to TapTalk only. Control User Level 1 and User Level 2 passwords protect access to the control from the front keypad.

When a communication password has been configured at the control, the communication password allows the user to bypass both the configuration and setpoint passwords otherwise required by a control.

■ **NOTE:** The communication password is identified as a string #. Therefore, the passwords "001" and "1" are not interchangeable.

Each control can be given a unique, 4-digit password ranging from 0 to 9999. If the password has been configured at the control as 0000, communication is not restricted a password does not need to be identified by TapTalk. The control is shipped with communication password disabled (set to 0000).

TapTalk password protection, when implemented, is as follows:

Default	View All
Level 1	Change Setpoints, Set Control Date/Time
Level 2	Change Setpoints, Configuration, DNP Configuration, Set New Passwords, Start Data Logging, Setup Data Logging, Remote Control, Set User Text Lines, Set Control Date/Time

To change **User Level** passwords perform the following:

1. Select **Control Setup/Set New Passwords** from the TapTalk toolbar, TapTalk will display the **Set New Passwords** dialog screen.
2. Select **User Level 1** or **User Level 2**.
3. Input a four digit password between 0 and 9999 in **New Password**.
4. Input the four digit password from Step 4, in **Confirm...**
5. Select **Setting**, then verify that TapTalk® displays the **New User Level Password has been set** confirmation.

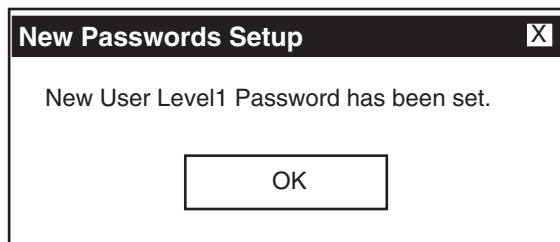
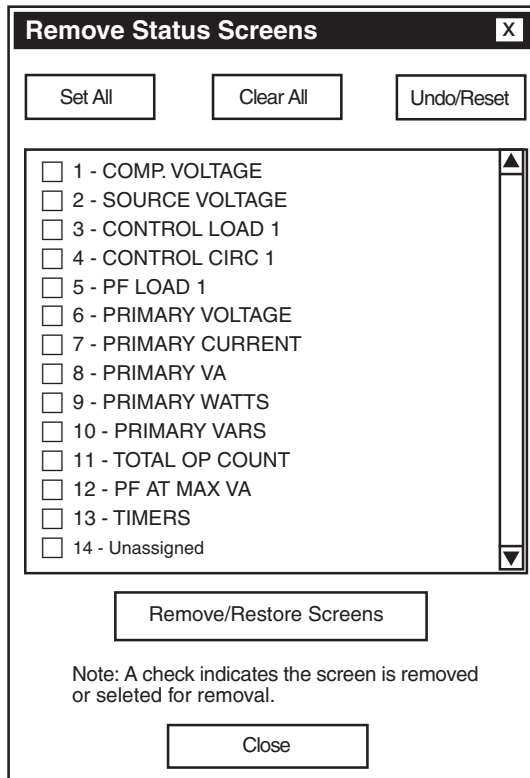

Figure 9-31 New User Level Password Confirmation Screen

**Remove Status Screens**

The **Remove Status Screen** allows the user to hide or restore status screens on the M-2001C (BASE-R).



*Figure 9-32 Remove Status Screens Selection Screen*

**Help**

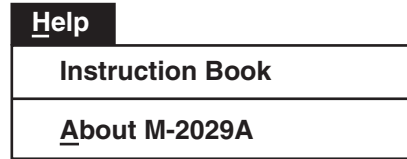

The **Help** toolbar item provides the user with information about the control and the software version that is installed in the unit.

**Help/Instruction Book**

The Instruction Book menu topic has been indexed to its Table of Contents. By selecting the 'Navigator pane' in Adobe Acrobat Read, the user can directly access selected topics.

**Help/About M-2029A**

The **About** submenu item provides the TapTalk software version number and copyright information.

**Window**

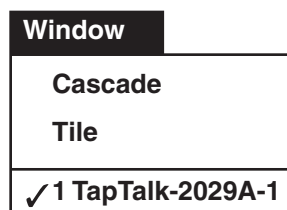

The **Window** toolbar item provides the **Cascade** and **Tile** display options. The **Window** toolbar item also allows the user to select between open TapTalk® windows.

## 9.8 Communication Cables

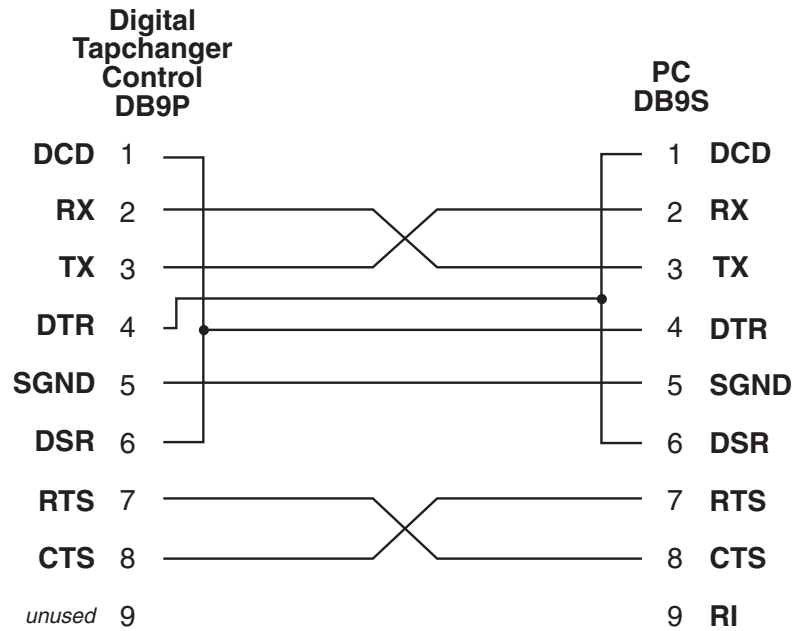

Figure 9-33 Null Modem Cable 9-Pin to 9-Pin

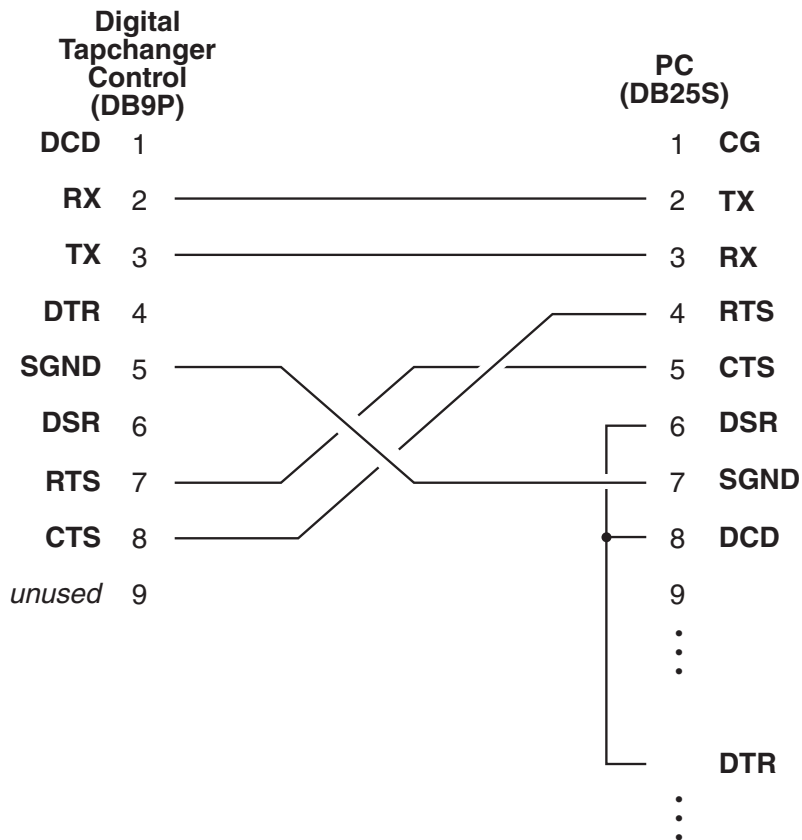

Figure 9-34 Null Modem Cable 9-Pin to 25-Pin

	<b>Digital Tapchanger Control (DB9P)</b>		<b>Modem (DB25S)</b>
<b>DCD</b>	1	—————	8
<b>RX</b>	2	—————	3
<b>TX</b>	3	—————	2
<b>DTR</b>	4	—————	20
<b>SGND</b>	5	—————	7
<b>DSR</b>	6	—————	6
<b>RTS</b>	7	—————	4
<b>CTS</b>	8	—————	5
<i>unused</i>	9		

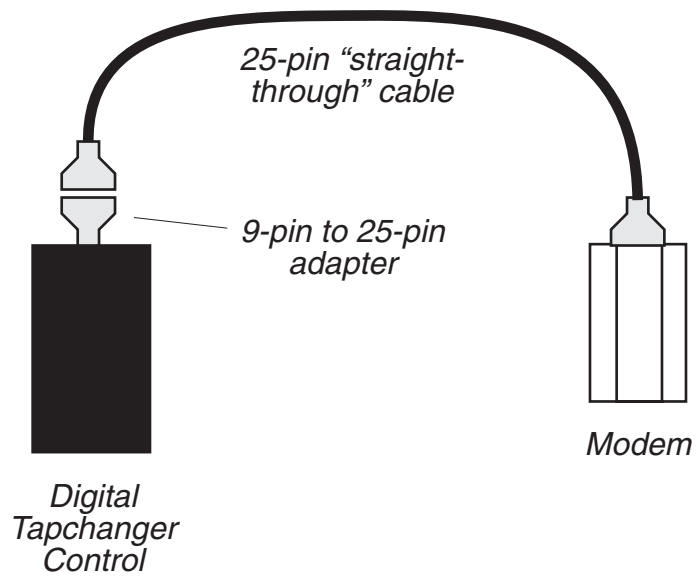

Figure 9-35 Modem Cable 9-Pin to 25-Pin

## 9.9 M-2829 TapPlot™ Analysis Software

The M-2829 TapPlot™ Analysis Software operates in conjunction with all TapTalk® Communications Software on any IBM PC-compatible computer. TapPlot allows the user to plot and print tap data retrieved from Beckwith Electric M-2001 series Digital Tapchanger Controls utilizing the Data Logging feature of TapTalk.

### Installation

TapPlot runs with the Microsoft Windows 95, 98, NT 4.0, 2000, or XP operating system. Familiarity with Windows is important in using TapPlot, as the conventions defined in the Windows documentation are strictly followed therein.

TapPlot will be installed on the host PC's hard disk. While it does not require special installation procedures, an installation utility has been provided to make the process easier.

To install TapPlot:

1. Insert the TapPlot software into your CD-ROM drive.
2. Select **Run** from the **Start Menu**.
3. In the **Run** dialog box, initiate software installation by typing **D:\Setup.exe** (or other drive designator:\Setup.exe, depending on the letter designation for the CD-ROM drive).
4. The Installation Wizard will prompt the user through the installation process. After installation, the TapPlot program icon (located in the Becoware folder) can be placed on the desktop (Figure 9-36).



Figure 9-36 TapPlot Program-Item Icon

### Creating TapPlot Data Files

To create data files for viewing in TapPlot proceed as follows:

1. From the "Start" menu select the M-2029A TapTalk program.
2. From the TapTalk Main Menu select **Utilities\Data Logging\Data Logging Control Setup And Download**. TapTalk will display the Control Setup And Download screen (Figure 9-25).
3. Select the File Type as "TapPlot" file or "Both".
4. Perform the Data Logging download.
5. Close TapTalk.

### Starting TapPlot

1. Select the TapPlot program-item icon from the Becoware group in the Program Manager, or select TapPlot from the program list using the **Start** Menu. The TapPlot Window and Toolbar is displayed (Figure 9-37).
2. Select File->Open from the menu, and browse for the .tpf file.
3. Open the file. TapPlot should display the saved data, as shown in Figure 9-37.

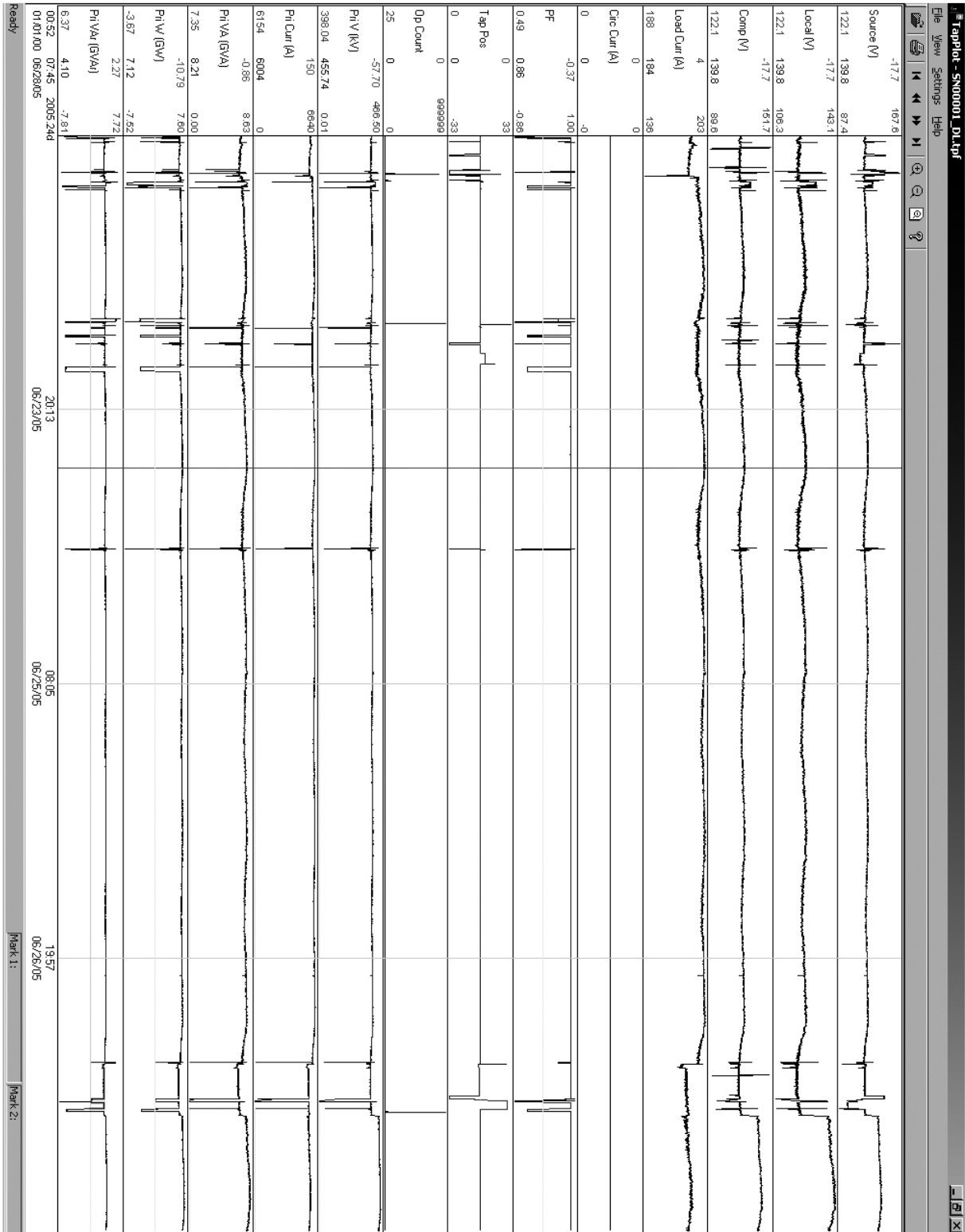

Figure 9-37 TapPlot Window and Tap Data Example

### Markers

TapPlot includes two user selectable markers. The first is positioned by double clicking on the plotted wave form data. The second is positioned by pressing and holding the **SHIFT** key and then double clicking on the plotted wave form data.

The markers can be dragged by moving the cursor over the marker until the cursor changes to a double-headed arrow  $\leftrightarrow$ , then holding down the Left mouse button and dragging the marker. The marker can also be moved an interval at a time by pressing the **UP** or **DOWN** arrow key. The last cursor selected is the one that is moved. To toggle the active cursor, press the **T** key.

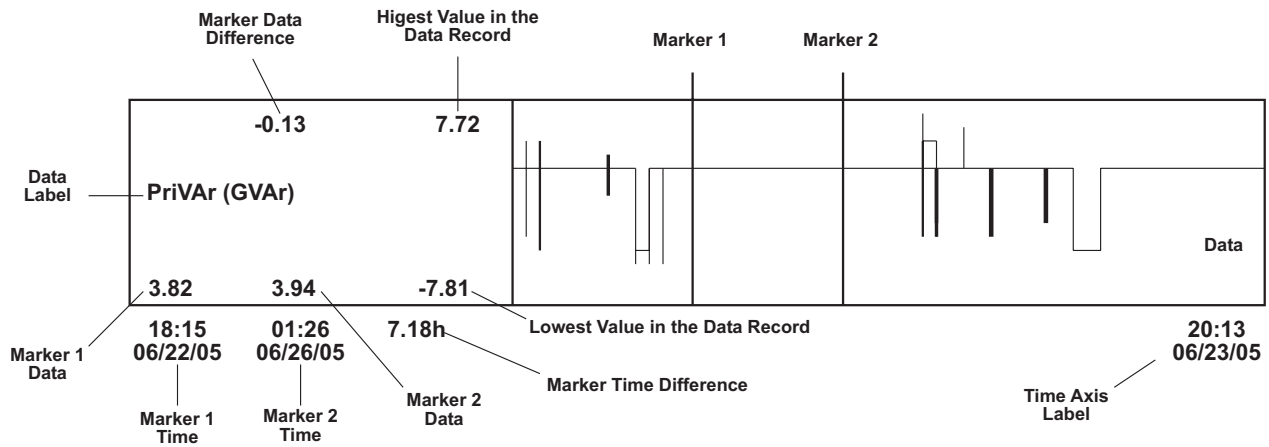

Figure 9-38 TapPlot Screen With Callouts



**Overview**

TapPlot is a windows based program for viewing the data that has been retrieved using the Data Logging feature of TapTalk.

When TapPlot is started, a menu and tool bar are displayed (see Figure 9-37). This section describes each TapPlot menu selection and explains each TapPlot command in the same order that they are displayed in the software program. Figure 9-39 presents the TapPlot Menu and Submenu Callouts.

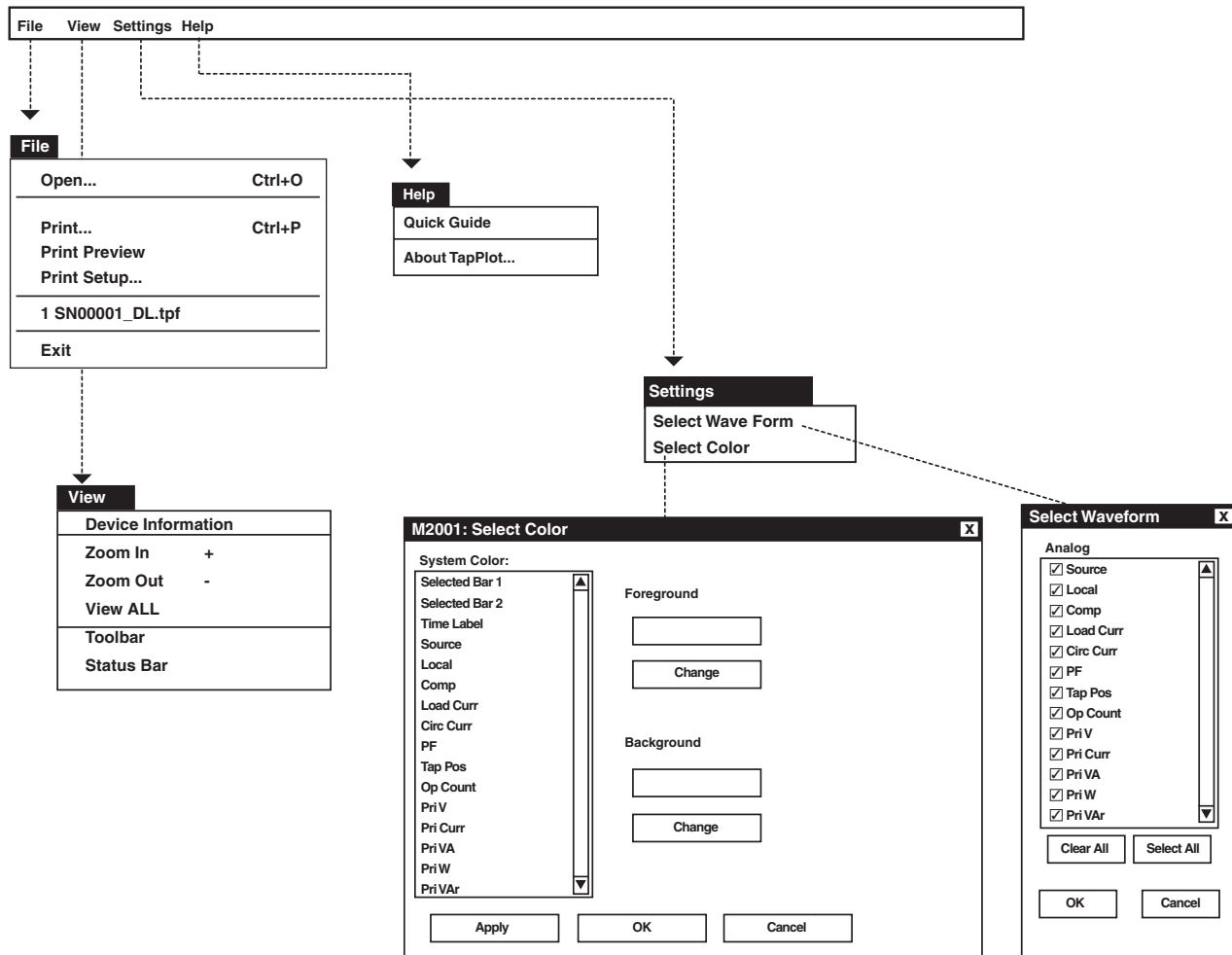
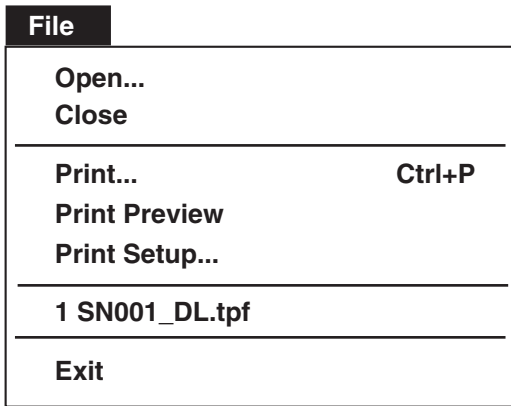

Figure 9-39 TapPlot Submenu Callouts

**File Menu**



The **File** menu allows the user to:

- Open a TapPlot (.tpf) file previously downloaded by TapTalk®.
- Print the displayed TapPlot data.
- Print Preview the displayed TapPlot data.
- Select the printer and printer settings to be used.
- Select from previously viewed .tpf files (the last four files displayed).
- Exit the TapPlot program.

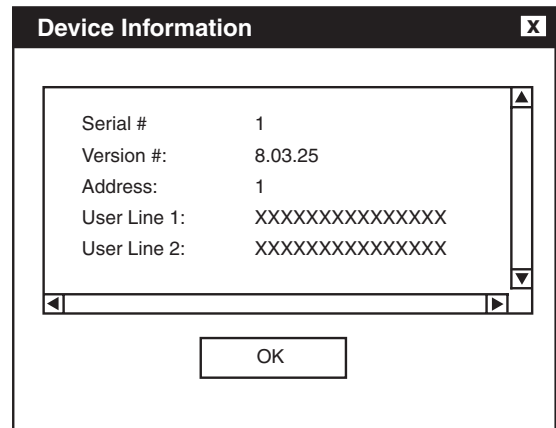

Figure 9-40 Device Information Screen

**Settings Menu**



The Settings menu allows the selection of the waveforms to be displayed and the format of display colors.

**View Menu**

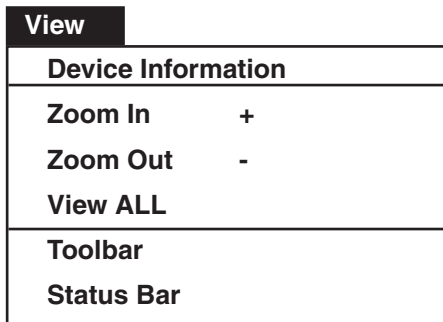

The **View** menu allows the user to:

- Display the Device Information (Figure 9-40) for the corresponding TapPlot data file.
- Zoom In, increase the resolution of the tap data displayed on the screen.
- Zoom Out, decrease the resolution of the tap data displayed on the screen.
- View ALL, returns the display to include all data within the record.
- Select which Tool Bar (Toolbar/Status Bar) is available on the display window.

**Select Waveform** allows the selection of any of the following Tap Parameters to be plotted or printed:

- Source Voltage (V)
- Local Voltage (V)
- Comp Voltage (V)
- Load Current (A)
- Circulating Current (A)
- Power Factor
- Tap Position
- Operation Counter
- Primary Voltage (kV)
- Primary Current (A)
- Primary VA (GVA)
- Primary Watts (GW)
- Primary VAr (GVAR)

The Waveform selections are made from the Select Waveform screen (Figure 9-41).

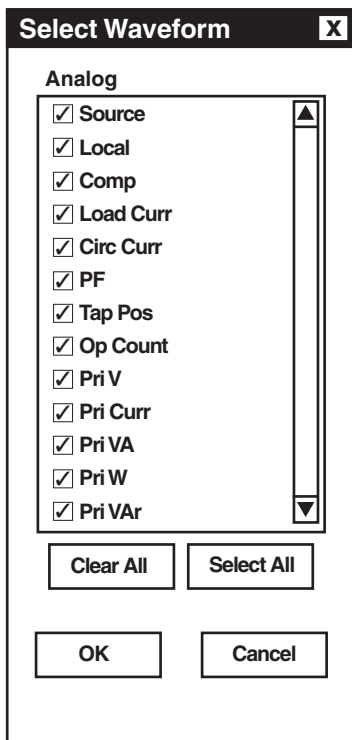

Figure 9-41 Select Waveform Dialog Screen

**Select Color** provides the user with the capability to change Foreground and Background display color of individual Waveform traces for customized plotting.

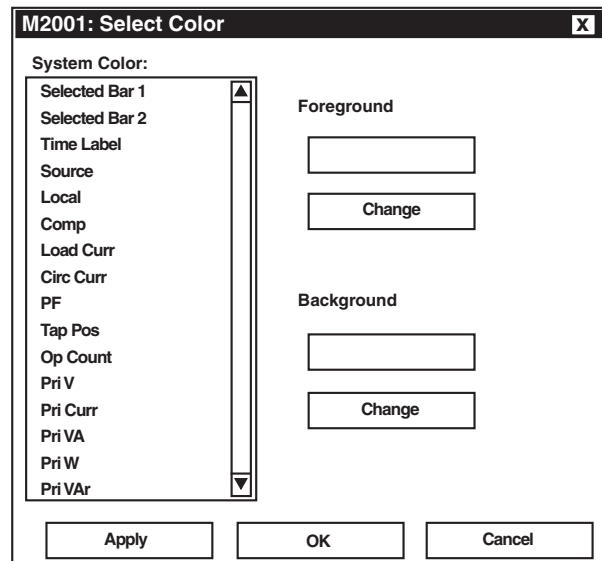
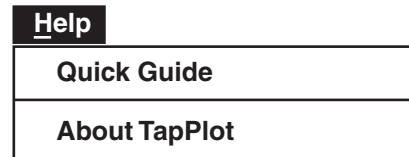

Figure 9-42 Select Color Dialog Screen

### Menu/Help Menu



The **Help** menu provides access to the **Quick Guide** which provides basic information about TapPlot menus and commands. The **About** command provides version information for TapPlot.

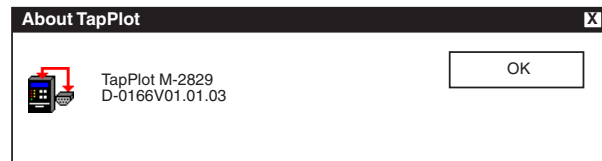

Figure 9-43 About TapPlot Screen

# A Appendix

A.0	Summary of Specifications .....	A-1
A.1	External Connections .....	A-1
A.2	Field Checkout Procedure .....	A-1
A.3	Screen Review .....	A-3
A.4	Setpoint and Configuration Worksheets .....	A-14

---

## A.0 Summary of Specifications

---

The following is a brief summary of specifications that may be required for installation. Please refer to specification sheets for complete information.

### Voltage withstand:

140 V continuous  
 240 V for one second  
 480 V for one cycle  
 Voltage measurement linear to 140 V

### Current withstand:

0.2 amps continuous  
 0.4 amps for 2 hours  
 4.0 amps for one second  
 Output raise and lower circuits:  
 6 amps AC

### Recommended external fusing:

Motor power input - 6 A  
 Voltage input - 1 A

---

## A.1 External Connections

---

See the Application Guide for the adapter panel being used.

The control's operating frequency can be 50 Hz or 60 Hz. This option may *not* be selected in the field.

---

## A.2 Field Checkout Procedure

---

■ **NOTE:** The following procedure assumes that the M-2001C (BASE-R) Tapchanger Control is connected to the front panel.

1. To wake unit from blank screen mode, press any pushbutton. Unit will display a series of power-up screens, then the Local Voltage screen.
2. Press the  pushbutton to go to the Bias Voltage-Test Mode screen.
3. Press **ENT** to reach the Bias Voltage input screen.

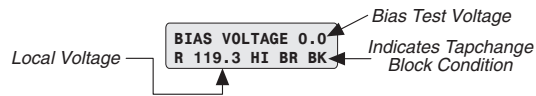

■ **NOTE:** If a Tapchange Block condition is indicated (see above), unit cannot be tested per this procedure. Therefore, make sure that you have placed the control in Automatic operation by using a communications protocol and resolving blocking condition.

4. Presuming that the unit is not in a Tapchange Block condition, set the **AUTO/OFF/MANUAL** switch to **MANUAL** and run the tapchanger control 3 or 4 steps in the Raise direction. Return the **AUTO/OFF/MANUAL** switch to Automatic.

5. Set the **AUTO/OFF/MANUAL** switch to **MANUAL** and run the tapchanger control 3 or 4 steps in the Lower direction. Return the **AUTO/OFF/MANUAL** switch to **AUTOMATIC**.
6. Press **ENT** to return to the **Bias Voltage Test Mode** screen. To exit from the unit's software, move through the screens using the **↑** and **↓** pushbuttons to one of the Exit screens. Press the **ENT** pushbutton. Unit will display a blank screen.

### A.3 Screen Review

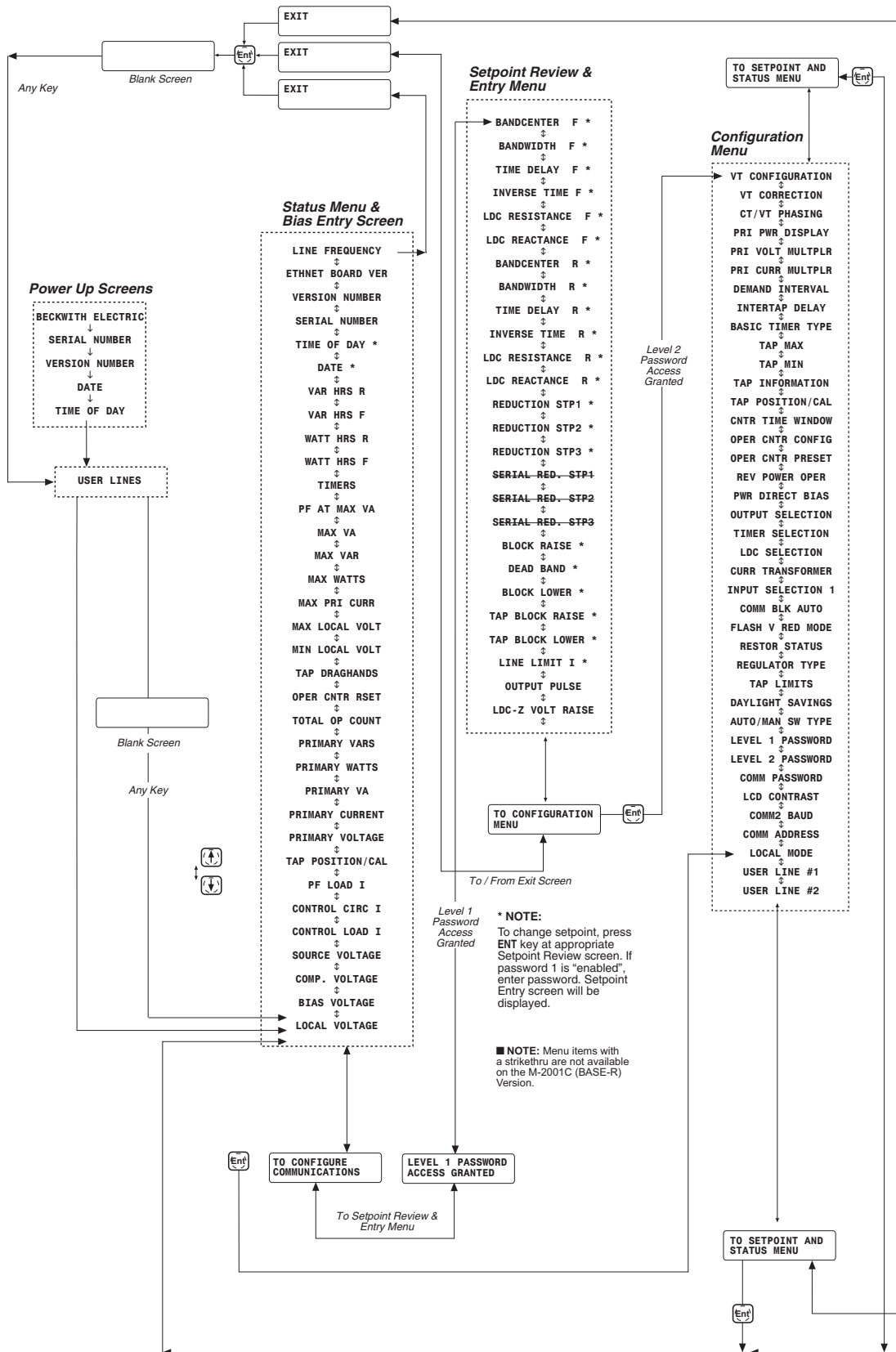

Figure A-1 Software Menu Flow

LINE FREQUENCY 60.10 Hz	Displays the line frequency. (Section 5.4)
ETHERNET BOARD VER Disable	Not available on the M-2001C (BASE-R).
VERSION NUMBER D-0146V01.00.00	Displays the M-2001C (BASE-R)'s software version number, and then any options that are present. The options are Mods, Delta VAR, Base Mode, and Backup Power.
SERIAL NUMBER 00023	Displays the Beckwith Electric M-2001C (BASE-R) serial number.
TIME OF DAY 08:15:00	Displays and allows resetting of the time of day. Press <b>E</b> to set time of day; change mode indicated by flashing C. Used in conjunction with memories where the date/time stamp will be recorded for each drag-hand quantity. (Section 5.3)
DATE 02/01/95	Displays and allows resetting of the date. Press <b>E</b> to set date; change mode indicated by flashing C. Used in conjunction with drag-hands memories where the date/time stamp will be recorded for each drag-hand quantity.
VAR HRS R 1/3 PH E 84.074 MVarHR	Displays total reverse VarHr in 1 or 3 phase determined by the PRI PWR DISPLAY configuration setting (Section 5.1). Bottom line toggles between date/time/VarHr.
VAR HRS F 1/3 PH E 47.879 MVarHR	Displays total forward VarHr in 1 or 3 phase determined by the PRI PWR DISPLAY configuration setting (Section 5.1). Bottom line toggles between date/time/VarHr.
WATT HRS R 1/3 PH E 234.687 MWHR	Displays total reverse WHr in 1 or 3 phase determined by the PRI PWR DISPLAY configuration setting (Section 5.1). Bottom line toggles between date/time/WHR.
WATT HRS F 1/3 PH E 899.002 MWHR	Displays total forward WHr in 1 or 3 phase determined by the PRI PWR DISPLAY configuration setting (Section 5.1). Bottom line toggles between date/time/WHR.
TIMERS R=0 L=0 IT=0	Displays the status of the raise, lower, and intertap timers; inverse or linear.
PF AT MAX VA 0.87 Lag/Lead	Displays power factor at time of maximum VA. Resets automatically when MAX VA screen, below, is reset.

Figure A-2 Status Screens (page 1 of 3)

■ **NOTE:** For detailed information on the above settings, see the referenced sections.

<p>MAX VA 1/3 PH E 2.12 MVA</p>	<p>Displays maximum VA in 1 or 3 phase determined by the PRI PWR DISPLAY configuration setting (Section 5.1). Bottom line toggles between date/time/MVA.</p>
<p>MAX VAR 1/3 PH E 0.67 MVAr</p>	<p>Displays maximum VAR in 1 or 3 phase determined by the PRI PWR DISPLAY configuration setting (Section 5.1). Bottom line toggles between date/time/MVAr.</p>
<p>MAX WATTS 1/3 PH E 1.98 MW</p>	<p>Displays maximum Watts in 1 or 3 phase determined by the PRI PWR DISPLAY configuration setting (Section 5.1). Bottom line toggles between date/time/MW.</p>
<p>MAX PRI CURR E 290 Amps</p>	<p>Displays maximum primary current. (Section 5.1) Bottom line toggles between date/time/Amps.</p>
<p>MAX LOCAL VOLT E 123.1 Volts</p>	<p>Displays maximum local voltage at the regulator or transformer. (Section 5.1) Bottom line toggles between date/time/Volts.</p>
<p>MIN LOCAL VOLT E 116.9 Volts</p>	<p>Displays minimum local voltage at the regulator or transformer. (Section 5.1) Bottom line toggles between date/time/Volts.</p>
<p>TAP DRAGHANDS E L=2L R=3R</p>	<p>Displays minimum and maximum values of tap position since reset. (Section 5.2)</p>
<p>OPER CNTR RSET E 0</p>	<p>Records the total number of raise and lower operations as does the total operations counter, discussed below. This counter is reset by pressing <b>ENT</b> at this screen. This counter can be used to monitor the number of tap changes since the last time it was checked. (Section 4.3)</p>
<p>TOTAL OP COUNT 1285</p>	<p>Records the total number of raise and lower operations. The operation counter will advance by one or two counts, as set by user, for each open-close-open contact operation. This counter is not resettable, but can be preset to any value between 0 and 999,999.(Section 4.3)</p>
<p>PRIMARY VARS 1/3 PH 1.44 mVAr</p>	<p>Displays the calculated primary quantity based on the user-selected multipliers, VT configuration (line-to-line or line-to-ground), single-phase or three-phase and measured secondary voltage and current. (Section 5.1)</p>
<p>PRIMARY WATTS 1/3 PH 3.00 MW</p>	
<p>PRIMARY VA 1/3 PH 3.30 MVA</p>	

Figure A-2 Status Screens (page 2 of 3)

■ **NOTE:** For detailed information on the above settings, see the referenced sections.



<p>PRIMARY CURRENT 133 Amps</p>	<p>Displays the calculated primary current based on the user-selected current multiplier and measured secondary current. (Section 5.1)</p>
<p>PRIMARY VOLTAGE 14.4 kV</p>	<p>Displays the calculated primary voltage based on the user-selected voltage multiplier and measured secondary voltage. (Section 5.1)</p>
<p>TAP POSITION/CAL 4 R</p>	<p>Displays the tap position of the tapchanger. Recognizes tapchanges commanded via manual, automatic or external (SCADA) means, if tap position not disabled. The tap position can be calibrated by selecting ENT, then setting the tap position using the <math>\uparrow/\downarrow</math> pushbuttons and then selecting ENT to confirm the new tap position.</p>
<p>PF LOAD I 0.90 Lag/Lead</p>	<p>Displays the real-time calculated value of power factor.</p>
<p>CONTROL CIRC I 0</p>	<p>Not available. This screen will always display zero.</p>
<p>CONTROL LOAD I 100 mA</p>	<p>Displays the real-time measured value of load current related to the scaling factor Current Transformer of 200 mA, 1 A or 5A.</p>
<p>SOURCE VOLTAGE 117.0 Volts</p>	<p>Displays the real-time calculated source voltage-only applicable in regulator control applications and includes any corrections made using the user-selected VT correction voltage.</p>
<p>COMP. VOLTAGE 120.0 Volts</p>	<p>Displays the calculated voltage at the “load center,” based on load current and the LDC settings.</p>
<p>BIAS VOLTAGE —STATUS/TST MODE—</p>	<p>When <b>ENT</b> is pressed, the control status can be checked, and a bias test voltage can be entered to test the control’s automatic operation. (Figure A-3)</p>
<p>LOCAL VOLTAGE 120.0 Volts</p>	<p>Displays the real-time measured value of voltage at the regulator or the transformer, including the voltage reduction if applicable and any corrections made using the user-selected VT correction voltage.</p>

Figure A-2 Status Screens (page 3 of 3)

■ **NOTE:** For detailed information on the above settings, see the referenced sections.

The six status screens shown above indicate “drag-hand values,” that is, minimum or maximum values of a parameter that are retained in non-volatile memory until reset by the user. The three screens for each parameter cycle continuously and indicate, respectively, the value, date and time of each parameter. The “E” located on the right top line indicates that by pressing **ENT** while viewing any of the three pertinent screens, the values retained in drag-hand memory will be reset to the present value. The unit is equipped with a real-time clock to allow a date/time stamp to be recorded in conjunction with each drag-hand quantity.

### Bias Voltage Function

When **ENT** is pressed from the Bias Voltage Test Mode screen, the bias test voltage can be entered to test the control's automatic operation. The figure below shows the status conditions indicated by this screen.

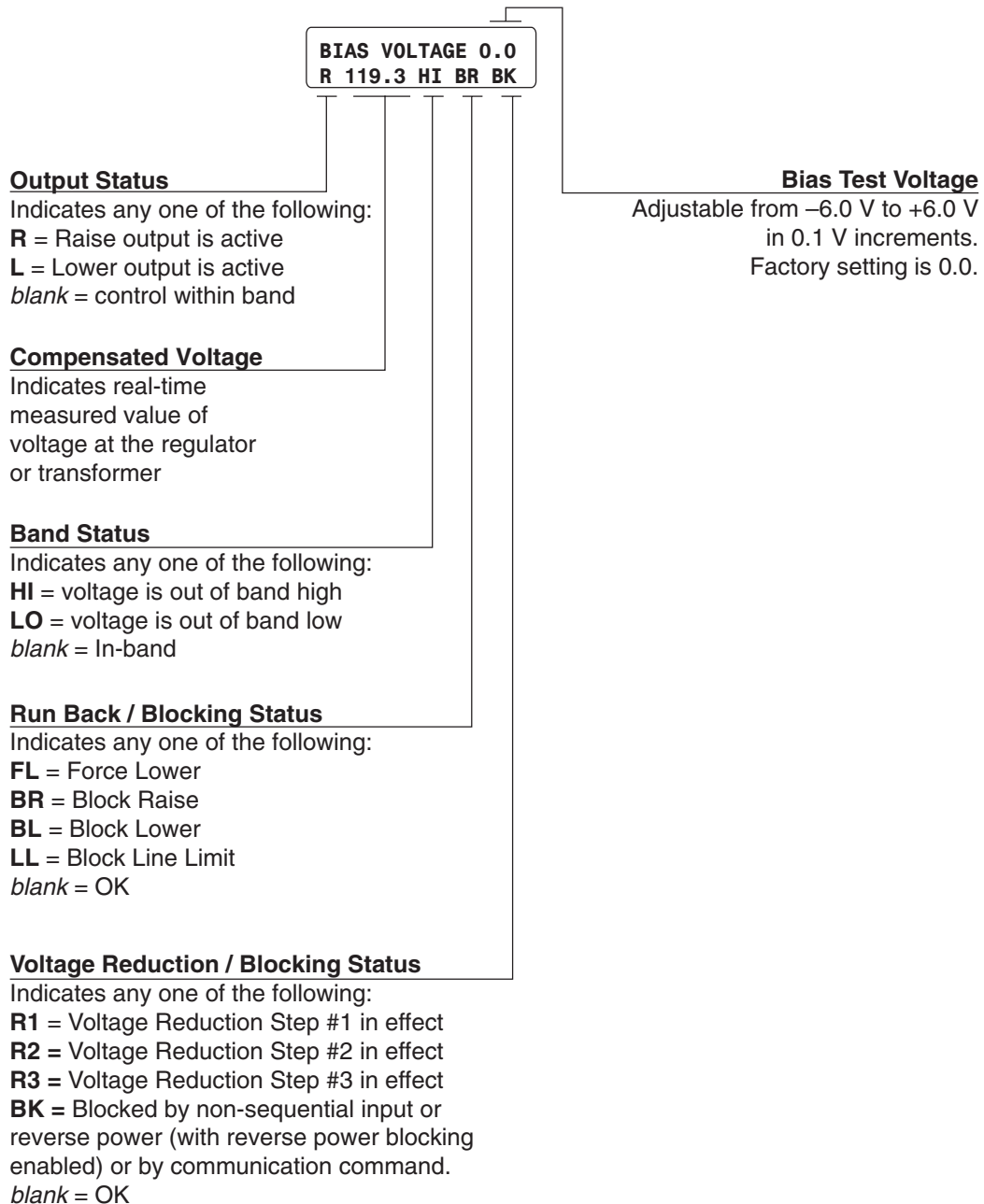

Figure A-3 Bias Test Voltage Screen

BANDCENTER F 120.0 Volts	Forward power bandcenter is adjustable from 100 V to 135 V in 0.1 V increments with a factory setting of 120 V. (Section 3.2)
BANDWIDTH F 2.0 Volts	Forward power bandwidth is adjustable from 1 V to 10 V in 0.1 V increments with a factory setting of 2.0 V. (Section 3.2)
TIME DELAY F 30 Sec	Forward power time delay for a tapchange is adjustable from 1 sec. to 120 sec. in 1 second increments with a factory setting of 30 sec. (Section 3.2)
INVERSE TIME F 30 Sec	Forward power inverse time delay for a tapchange is adjustable from 1 seconds to 120 seconds in 1 second increments, with a factory setting of 30 seconds. (Section 3.2)
LDC RESISTANCE F 0 Volts	Forward power Line Drop Compensation resistance is adjustable from -24 V to +24 V in 1 V increments with a factory setting of 0 V. (Section 3.2)
LDC REACTANCE F 0 Volts	Forward power Line Drop Compensation reactance is adjustable from -24 V to +24 V in 1 V increments with a factory setting of 0 V. (Section 3.2)
BANDCENTER R 120.0 Volts	Reverse power bandcenter is adjustable from 100 V to 135 V in 0.1 V increments with a factory setting of 120 V. (Section 3.2)
BANDWIDTH R 2.0 Volts	Reverse power bandwidth is adjustable from 1 V to 10 V in 0.1 V increments with a factory setting of 2.0 V. (Section 3.2)
TIME DELAY R 30 Sec	Reverse power time delay for a tapchange is adjustable from 1 sec. to 120 sec. in 1 second increments with a factory setting of 30 sec. (Section 3.2)
INVERSE TIME R 30 Sec	Reverse power inverse time delay for a tapchange is adjustable from 1 sec. to 120 sec. in 1 second increments with a factory setting of 30 sec. (Section 3.2).
LDC RESISTANCE R 0 Volts	Reverse power Line Drop Compensation resistance is adjustable from -24 V to +24 V in 1 V increments with a factory setting of 0 V. (Section 3.2)
LDC REACTANCE R 0 Volts	Reverse power Line Drop Compensation reactance is adjustable from -24 V to +24 V in 1 V increments, with a factory setting of 0 V. (Section 3.2)
REDUCTION STP1 2.5 %	First of three independent steps of voltage reduction adjustable from 0% to 10% in 0.1% increments of the bandcenter setpoint. Factory setting is 2.5% (Section 3.3)

Figure A-4 Setpoint Screens (page 1 of 2)

■ **NOTE:** For detailed information on the above settings, see the referenced sections.

REDUCTION STP2 5.0 %	Second voltage reduction step. Factory setting is 5.0% (Section 3.3)
REDUCTION STP3 7.5 %	Third voltage reduction step. Factory setting is 7.5% (Section 3.3)
SERIAL RED STP1 2.5 %	This function is not available on the M-2001C (BASE-R).
SERIAL RED STP2 5.0 %	This function is not available on the M-2001C (BASE-R).
SERIAL RED STP3 7.5 %	This function is not available on the M-2001C (BASE-R).
BLOCK RAISE 128.0 Volts	Overvoltage limit is adjustable from 95 V to 135 V in 0.1 V increments with a factory setting of 128 V. The Block Raise setpoint should always be set above the Block Lower setpoint and above the upper band limit (the bandcenter plus one-half of the bandwidth) for the control to operate. (Section 3.4)
DEAD BAND 2.0 Volts	Deadband is adjustable from 1 V to 4 V in 0.1 V increments with a factory setting of 2.0 V. (Section 3.4)
BLOCK LOWER 114.0 Volts	Undervoltage limit is adjustable from 95 V to 135 V in 0.1 V increments with a factory setting of 114 V. The Block Lower setpoint should always be set below the Block Raise setpoint and below the lower band limit (the bandcenter minus one-half of the bandwidth) for the control to operate. (Section 3.4)
TAP BLOCK RAISE 16 R	A factory setting of 16 Raise.
TAP BLOCK LOWER 16 L	A factory setting of 16 Lower.
LINE LIMIT I 400 mA	Line limit is adjustable from 200 mA to 640 mA in 1 mA increments with a factory setting of 400 mA with hysteresis of 5 mA. If the value of the current exceeds the line limit setpoint, the unit will not permit automatic control. (Section 3.4)
OUTPUT PULSE 1.5 Sec	Adjustable from 0.2 to 12 seconds in 0.1 second increments. Factory set at 1.5 seconds. (Section 3.5)
LDC-Z VOLT RAISE 0 Volts	Adjustable from 0 to 24 volts in 1.0 volt increments. (Section 3.2)

Figure A-4 Setpoint Screens (page 2 of 2)

■ **NOTE:** For detailed information on the above settings, see the referenced sections.

VT CONFIGURATION Line-to-Ground	VT configuration toggles between Line-to-Line and Line-to-Ground with a factory setting of Line-to-Ground.
VT CORRECTION 0.0 Volts	VT ratio correction is adjustable from -15 V to +15 V in 0.1 V increments with a factory setting of 0 V. (Section 4.4)
CT/VT PHASING 0 Deg	CT/VT phasing correction is adjustable from 0° to 330° in 30° increments with a factory setting of 0°. This setting will advance the current phasor by the indicated value. (Section 4.4)
PRI PWR DISPLAY Single_Phase	Toggles between two modes of operation: Single-Phase-based on measured inputs, and Three-Phase-based on measured inputs and presumed balanced system. Factory setting is single-phase.
PRI VOLT MULTPLR 60.0 X	Adjustable from 0.1 to 3260 in 0.1 increments with a factory setting of 60. User selection to include knowledge of VT ratio, sensing VT ratio correction and indication of either line-to-line or line-to-ground voltage. (Section 4.5)
PRI CURR MULTPLR 6000 X	Adjustable from 1 to 32600 in 1.0 increments with a factory setting of 6000. User selection to include knowledge of CT ratio, from primary rating to 0.2 A rating of control. (Section 4.5)
DEMAND INTERVAL 15 Min	Toggles between 15, 30 and 60 minute interval with a factory setting of 15 minutes. The time interval is the amount of time it takes for a thermal meter to indicate 90% of a change of load. (Section 5.1)
INTERTAP DELAY 0 Sec	Adjustable from 0 to 60 Seconds in 1.0 second increments with a factory setting of 0 seconds. (Section 3.6)
BASIC TIMER TYPE INTEGRATING	Toggles between integrating timer and instantaneous reset (INST_RESET) timer upon voltage return to in-band condition. (Section 4.10)
TAP MAX 16 R	Maximum allowed upper tap. May be set from 0 to 33 R. Tap Range must be less than 34. Factory default = 16R. (Section 4.6)
TAP MIN 16 L	Minimum allowed lower tap. May be set from 33L to 29R. Factory default = 16L. (Section 4.7) Note that <b>Tap Max</b> must be 4 taps greater than <b>Tap Min</b> (-33 to +29).
TAP INFORMATION DISABLE	Toggles between Reg Internal and Disable. Factory setting is Disable. See Table 4.1.(Section 4.6)
TAP POSITION/CAL 0 Neutral	Allows input of known tap position to calibrate the unit tap position. This function is disabled when Tap Information is disabled. (Section 4.6)

Figure A-5 Configuration Screens (page 1 of 4)

■ **NOTE:** For detailed information on the above settings, see the referenced sections.

<p>CNTR TIME WINDOW 0.5 Sec</p>	<p>Allows the Counter Time Window to be set from 0.5 to 10.0 seconds. This screen is enabled when "Oper Cntr Config" is set to "count window", otherwise, it is disabled. (Section 4.3)</p>
<p>OPER CNTR CONFIG 1 X (2 X count window)</p>	<p>Selects the contact operation sequence that will cause the software counter to increment by one. Open/close/open (X1), open/close or close/open contact operation (X2). The count window mode registers any activity as a valid input within the count window time setting. (Section 4.3)</p>
<p>OPER CNTR PRESET 000000</p>	<p>Presets a number in the Total Operations Counter. (Section 4.3)</p>
<p>REV POWER OPER BLOCK</p>	<p>Toggles between four modes of operation: Ignore-to continue unit action as though Forward Power Flow continued to exist, Block-to inhibit automatic tapchange operation, Regulate Rev-to detect a reverse power condition and regulate according to reverse power settings and Return to Neutral to drive the tap position to Neutral. Factory setting is Block. (Section 4.7)</p>
<p>PWR DIRECTION BIAS none</p>	<p>Allows one of three methods to be used for the control to switch between forward/reverse power operation. The three settings are None, Forward Bias, and Reverse Bias (Section 4.7).</p>
<p>OUTPUT SELECTION CONTINUOUS</p>	<p>Allows choice of output at tapchanger Raise/Lower output pin. Choices are continuous or pulsed. For continuous, the control must wait to be in band or counter input valid for output to become disabled. For pulse, an adjustable width pulse will be applied to the output triacs of 0.2 to 12 seconds. (Section 4.8)</p>
<p>TIMER SELECTION DEFINITE</p>	<p>Allows setting control timer for Definite or Inverse time. There are four setpoints associated with this selection: Time Delay F/R, and Inverse Time F/R. (Section 3.2)</p>
<p>LDC SELECTION RES-REAC</p>	<p>Allows Line Drop Compensation to be either Resistance/Reactance or Z-compensated. (Section 3.2)</p>
<p>CURR TRANSFORMER 200 mA</p>	<p>Selection of display current can be made to be either 200 mA, 1 A or 5 A. This screen allows load and circulating current displays to be viewed on 200mA, 1A or 5A scales. Line Limit I settings also affected. (Section 4.12) <b>▲ CAUTION:</b> The current input to the control is rated at 0.2 A continuous, 0.4 A for two hours, and 4.0 A for one second.</p>
<p>INPUT SELECTION 1 SEAL IN</p>	<p>Allows the seal-in input to be used as a seal-in input or a switch status input. When the Switch Status input mode is selected, all Seal-In input functions will be disabled (Section 6.1). The factory setting is Seal In.</p>
<p>COMM BLK AUTO dont save</p>	<p>Allow the state of the "Block Auto Operation" communication command to be saved or not saved when power has been lost.</p>

Figure A-5 Configuration Screens (page 2 of 4)

■ **NOTE:** For detailed information on the above settings, see the referenced sections.

FLASH V RED MODE disable	Allows the flashing voltage reduction status screen to be enabled/disabled (Section 5.5). ■ <b>NOTE:</b> Enabling this function may shorten the life of the screen.
RESTORE STATUS SCREENS	Allows any of the status screens which may have been removed to be restored in the status menu (Section 5.6)
REGULATOR TYPE A B	Allows the regulator type to be selected as Type A or B for correct source voltage calculation. (Section 4.13) Factory setting is Type A.
TAP LIMITS ENABLED	Allows the Tap Position Limits to be enabled/disabled (Section 3.4.)
DAYLIGHT SAVINGS enable          disable	Allows automatic Daylight Savings time adjustment to be enabled or disabled.
AUTO/MAN SW TYPE toggle NONE	Allows the Auto/Man switch type on the adapter panel to be set to toggle or NONE. NONE is used when no Auto/Manual switch exists.
LEVEL 1 PASSWORD 0000	Configures a four-digit numerical password for Level 1. Factory setting is 0000 (disabled). (Section 4.1)
LEVEL 2 PASSWORD 2222	Configures a four-digit numerical password for Level 2. Factory setting is 2222. (Section 4.1)
COMM PASSWORD 0000	Configures a four-digit numerical password for remote communications. Factory setting is 0000. (Section 4.1)
LCD CONTRAST 0	Allows contrast to be adjusted from +10 (lightest) to -10 (darkest). Factory setting is 0, which provides a neutral contrast.
COMM 2 BAUD 9600	Selects baud rate for COM2, located in front of control. (Section 6.5)
COMM ADDRESS 1	Configures a three-digit numerical address, from 1 to 200, for remote communications, using BECO2200 protocol. Factory setting is 1. (Section 4.1)

*Figure A-5 Configuration Screens (page 3 of 4)*

■ **NOTE:** For detailed information on the above settings, see the referenced sections.

COMM 2 DEAD-SYNC  
50 msec

This time delay improves robust operation when communication lines are intermittent. Communication dead-sync time is the time that the control will wait from the last received character and continue without attempting to resynchronize. Factory setting is 50 msec; range is 0-32000 msec.

LOCAL MODE  
NO READ OR WRITE

Allows control of reading/writing setpoints and configurations via communications. There are 4 settings associated: Disable, Read Only, Always Read Only, and No Read or Write. When set to Disable, read/write communication will be available at all times. When set to Read Only, read/write communication will be available only when the front panel of the control is inactive. If the front panel is active, only reads via communications will be allowed. When set to Always Read Only, only reads via communications will be allowed regardless of whether the front panel is active or not. When set to No Read or Write, read/write communication will be available only when the front panel to the control is inactive. If the front panel is active, no communications will be allowed.

USER LINE #1  
\*\*\*\*\*

Allows input of 15 ASCII characters to configure a unit locator or description. If not configured, a row of 15 asterisks will appear in top row of User Line #1 screen. (Section 4.2)

USER LINE #2  
\*\*\*\*\*

Allows input of 15 ASCII characters to configure a unit locator or description. If not configured, a row of 15 asterisks will appear in bottom row of User Line #2 screen. (Section 4.2)

*Figure A-5 Configuration Screens (page 4 of 4)*

■ **NOTE:** For detailed information on the above settings, see the referenced sections.



### A.4 Setpoint and Configuration Worksheets

Use these forms to record the M-2001C unit configuration. These forms can be given to a technician for configuring the M-2001C, or changing the setpoints, and kept on file for future reference.

BANDCENTER F _____ Volts	REDUCTION STP1 _____ %
BANDWIDTH F _____ Volts	REDUCTION STP2 _____ %
TIME DELAY F _____ Sec	REDUCTION STP3 _____ %
INVERSE TIME F _____ Sec	SERIAL RED STP1 _____ %
LDC RESISTANCE F _____ Volts	SERIAL RED STP2 _____ %
LDC REACTANCE F _____ Volts	SERIAL RED STP3 _____ %
BANDCENTER R _____ Volts	BLOCK RAISE _____ Volts
BANDWIDTH R _____ Volts	DEAD BAND _____ Volts
TIME DELAY R _____ Sec	BLOCK LOWER _____ Volts
INVERSE TIME R _____ Sec	TAP BLOCK RAISE _____ R
LDC RESISTANCE R _____ Volts	TAP BLOCK LOWER _____ L
LDC REACTANCE R _____ Volts	LINE LIMIT I _____ mA
	OUTPUT PULSE _____ Sec
	LDC-Z VOLT RAISE _____ Volts

Figure A-6 Setpoint Worksheet

V.T. CONFIGURATION line_to_line line_to_gnd	CNTR TIME WINDOW _____ Sec
VT CORRECTION _____ Volts	OPER CNTR CONFIG 1X 2X count window
CT/VT PHASING _____ Deg	OPER CNTR PRESET _____
PRI PWR DISPLAY single_phase three_phase	REV POWER OPER regulate rev ignore block→
PRI VOLT MULTPLR _____ X	REV POWER OPER ← return to neutral
PRI CURR MULTPLR _____ X	PWR DIRECT BIAS rev bias fwd bias none
DEMAND INTERVAL 15 30 60 Minutes	OUTPUT SELECTION continuous pulse
INTERTAP DELAY _____ Sec	TIMER SELECTION linear inverse
BASIC TIMER TYPE integrating inst_reset	LDC SELECTION res_reac z_compensated
TAP MAX 16 R	CURR TRANSFORMER 200mA 1A 5A
TAP MIN 16 L	INPUT SELECTION 1 seal-in switch status
TAP INFORMATION Internal Disable	COMM BLK AUTO dont save save at pwr off
TAP POSITION/CAL __ L Neutral __R	FLASH V RED MODE enable disable

Figure A-7 Configuration Worksheet (page 1 of 2)

REGULATOR TYPE a b	USER LINE #1 _____
TAP LIMITS enable disable	USER LINE #2 _____
DAYLIGHT SAVINGS enable      disable	
AUTO/MAN SW TYPE toggle      NONE	
LEVEL 1 PASSWORD _____	
LEVEL 2 PASSWORD _____	
COMM PASSWORD _____	
LCD CONTRAST _____	
COMM 2 BAUD 1200 2400 4800 9600 19200	
COMM ADDRESS _____	
COMM DEAD-SYNC _____ msec	
LOCAL MODE no rd or write always rd only→  ← read only disable	

Figure A-7 Configuration Worksheet (page 2 of 2)

# **B** Appendix B – M-2029A Data Output

This Appendix contains illustrations of the print-ready screens provided by M-2029A's Data Output command.

## M-2001C (BASE-R) Instruction Book

Beckwith Electric Co. Inc.  
TapTalk M-2029A Data Profile

---

### CONTROL INFORMATION:

Identification:	M-2001C
Serial Number:	1
Version:	D-0146V09.01.21
Modification Number:	-
User Line 1:	xxxxxxxxxxxxxxxx
User Line 2:	xxxxxxxxxxxxxxxx
Comm Address:	2
Control Date:	Mon/Feb/16 / 04
Control Time:	15 :09 : 59

CONNECTION TYPE: Serial Com1

### CONTROL COM:

Local Mode: Disable

### BASIC SETPOINTS:

Forward Band Center:	120.00 V
Forward Band With:	2.00 V
Forward Time Delay:	4 sec
Forward Inverse Time Delay:	30 secs
Forward LDC Resistance:	0 V
Forward LDC Reactance:	0 V
Reverse Band Center:	120.00 V
Reverse Band With:	2.00 V
Reverse Time Delay:	30 secs
Reverse Inverse Time Delay:	30 secs
Reverse LDC Resistance:	0 V
Reverse LDC Reactance:	0 V
Voltage Reduction 1:	2.50 %
Voltage Reduction 2:	5.00 %
Voltage Reduction 3:	10.00 %
Block Raise (Voltage):	135.00 V
Block Lower (Voltage):	95.00 V
Dead Band:	2.00 V
Current Limit:	640.00 mA
Block Raise (Tap):	16 R
Block Lower (Tap):	16 L
Output Pulse Width:	1.50 sec
Line Drop Compensation - Z:	0 V

### CONFIGURATION:

VT Configuration:	Line To GroundV
VT Correction:	0.00 Volts
CT/VT Phasing:	0 Degree
Primary Power Display:	Single Phase
Primary Voltage Multiplier:	60.00 x
Primary Current Multiplier:	6000.00 x
Demand Interval:	15 minutes
Intertap Delay:	0 sec
Tap Information:	Reg. Internal
Operation Counter Configuration:	X1
Reverse Power Operation:	Regular Reverse
Paralleling:	Disable
Basic Timer Type:	Integrating
Tap Max:	16 R
Tap Min:	16 L
Output Selection:	Continuous
Input Selection 1:	Switch Status
Time Delay Selection:	Definite

Figure B-1 Data Output (Page 1 of 3)

Beckwith Electric Co. Inc.  
TapTalk M-2029A Data Profile

---

Current Transformer Selection:	200 mA
Line Drop Compensation:	X,R
Power Direction Bias:	None
Flash Voltage Reduction Mode:	Enable
Input Selection 2:	Non-Sequential
Regulator Type	B
Count Window:	2.0 sec

## ALARM CONFIGURATION:

Block Lower (Volt):	Enabled
Block Raise (Volt):	Enabled
Block Lower (Tap):	Enabled
Block Lower (Tap):	Enabled
Current Limit:	Enabled
Reverse Power:	Enabled
Voltage Reduction:	Enabled
Block Comm:	Enabled

## STATUS:

Primary Volts:	17.17 kV
Primary Current:	1.00 Amps
Primary Watts:	0.00 MW
Primary VAr:	0.00 MVA
Primary VA:	0.00 MVA
Frequency:	60.00 Hz
Local Voltage:	119.60 Volts
Source Voltage:	119.60 Volts
Load Current (Secondary):	0.00 mA
Comp. Voltage:	119.60 Volts
Circ. Current (Secondary):	0.00 mA
Power Factor:	0.67 Lag
Raise Timer:	0 sec
Lower Timer:	0 sec
Intertap Timer:	0 sec
Operation Counter:	793
Tap Position:	0 Neutral
Band Status:	OK
Power Direction:	Forward
Operation Direction:	Forward
Voltage Red. In Effect:	OFF
Voltage Red. Step:	No Red.

## DEMAND METERING:

## Present:

Interval:	15 Minutes
Local Voltage:	119.90 Volts
Primary Current:	0.00 Amps
Primary Watts:	0.00 MW
Primary VAr:	0.00 MVA
Primary VA:	0.00 MVA

## HISTORY:

Local Voltage (Min):	112.50 Volts	[14:43:52 Feb/12/04]
Local Voltage (Max):	123.10 Volts	[07:28:02 Feb/15/04]
Primary Current (Max):	1.00 Amps	[07:49:14 Feb/12/04]
Primary Watts (Max):	0.00 MW	[12:34:22 Feb/12/04]
Primary VAr (Max):	0.00 MVA	[07:49:14 Feb/12/04]
Primary VA (Max):	0.00 MVA	[20:43:32 Feb/13/04]
Power Factor at Max VA:	0.58 Lag	
Raise Tap Draghand:	0	
Lower Tap Draghand:	0	

Figure B-2 Data Output (Page 2 of 3)

**M-2001C (BASE-R) Instruction Book**

Beckwith Electric Co. Inc.  
TapTalk M-2029A Data Profile

---

Energy Metering:

Watt Hours (Forward):	184.52 MWHrs	[19:08:38 Dec/31/99]
Watt Hours (Reverse):	0.00 KWHrs	[19:08:37 Dec/31/99]
VAr Hours (Forward):	2.58 MVarHrs	[19:08:37 Dec/31/99]
VAr Hours (Reverse):	36.23 MVarHrs	[19:08:38 Dec/31/99]

*Figure B-3 Data Output (Page 3 of 3)*

## Patent

The units described in this manual are covered by U.S. Patents, with other patents pending.

Buyer shall hold harmless and indemnify the Seller, its directors, officers, agents, and employees from any and all costs and expense, damage or loss, resulting from any alleged infringement of United States Letters Patent or rights accruing therefrom or trademarks, whether federal, state, or common law, arising from the Seller's compliance with Buyer's designs, specifications, or instructions.

## Warranty

Seller hereby warrants that the goods which are the subject matter of this contract will be manufactured in a good workmanlike manner and all materials used herein will be new and reasonably suitable for the equipment. Seller warrants that if, during a period of five years from date of shipment of the equipment, the equipment rendered shall be found by the Buyer to be faulty or shall fail to perform in accordance with Seller's specifications of the product, Seller shall at his expense correct the same, provided, however, that Buyers shall ship the equipment prepaid to Seller's facility. The Seller's responsibility hereunder shall be limited to replacement value of the equipment furnished under this contract.

*Seller makes no warranties expressed or implied other than those set out above. Seller specifically excludes the implied warranties of merchantability and fitness for a particular purpose. There are no warranties which extend beyond the description contained herein. In no event shall Seller be liable for consequential, exemplary, or punitive damages of whatever nature.*

Any equipment returned for repair must be sent with transportation charges prepaid. The equipment must remain the property of the Buyer. The aforementioned warranties are void if the value of the unit is invoiced to the Seller at the time of return.

## Indemnification

The Seller shall not be liable for any property damages whatsoever or for any loss or damage arising out of, connected with, or resulting from this contract, or from the performance or breach thereof, or from all services covered by or furnished under this contract.

In no event shall the Seller be liable for special, incidental, exemplary, or consequential damages, including but not limited to, loss of profits or revenue, loss of use of the equipment or any associated equipment, cost of capital, cost of purchased power, cost of substitute equipment, facilities or services, downtime costs, or claims or damages of customers or employees of the Buyer for such damages, regardless of whether said claim or damages is based on contract, warranty, tort including negligence, or otherwise.

Under no circumstances shall the Seller be liable for any personal injury whatsoever.

It is agreed that when the equipment furnished hereunder are to be used or performed in connection with any nuclear installation, facility, or activity, Seller shall have no liability for any nuclear damage, personal injury, property damage, or nuclear contamination to any property located at or near the site of the nuclear facility. Buyer agrees to indemnify and hold harmless the Seller against any and all liability associated therewith whatsoever whether based on contract, tort, or otherwise. Nuclear installation or facility means any nuclear reactor and includes the site on which any of the foregoing is located, all operations conducted on such site, and all premises used for such operations.

## Notice:

Any illustrations and descriptions by Beckwith Electric Co., Inc. are for the sole purpose of identification.

The drawings and/or specifications enclosed herein are the proprietary property of Beckwith Electric Co., Inc., and are issued in strict confidence; therefore, shall not be used as a basis of reproduction of the apparatus described therein without written permission of Beckwith Electric Co., Inc.

No illustration or description contained herein shall be construed as an express warranty of affirmation, promise, description, or sample, and any and all such express warranties are specifically excluded nor shall such illustration or description imply a warranty that the product is merchantable or fit for a particular purpose. There shall be no warranties which extend beyond those contained in the Beckwith Electric Co., Inc. terms of sale.





**BECKWITH ELECTRIC CO., INC.**

6190 - 118th Avenue North • Largo, Florida 33773-3724 U.S.A.

PHONE (727) 544-2326 • FAX (727) 546-0121

E-MAIL [marketing@beckwithelectric.com](mailto:marketing@beckwithelectric.com)

WEB PAGE [www.beckwithelectric.com](http://www.beckwithelectric.com)