



Instruction Book

**M-0329B LTC
Backup Control**

BECKWITH  **CO. INC.**
ELECTRIC

LTC Backup Control M-0329B



- Prevents a defective LTC tapchanger control from running the voltage outside the upper or lower limits
- Prevents the line drop compensator from raising the voltage too high under full or overload conditions
- Fully transient protected and operates within $\pm 1\%$ voltage accuracy over a temperature range of -40° to $+80^{\circ}$ C
- Includes First Customer Protection

M-0329B Backup Control

The M-0329B LTC Backup Control provides the extra protection that can save your customers from the hazards and inconvenience of excessively high or low voltage. Defective LTC tapchanger controls can cause either too high or too low a voltage along the line, possibly damaging customers' motors, computers or televisions. Even when the control is operating properly, customers close to the transformer may receive dangerously high voltage as the line drop compensator attempts to maintain a constant voltage under heavy load at a central point on the distribution line. The Beckwith Electric M-0329B LTC Backup Control can be installed as a solution to both of these problems.

The LTC Backup Control will prevent a defective LTC tapchanger control from running the voltage outside the upper and lower voltage limits and, in addition, will prevent the line drop compensator from raising the voltage too high under full load or overload conditions. Setting the voltage bands on the M-0329B slightly wider than the transformer control limits will assure that a failed control will not result in a runaway LTC transformer. Under full or overload conditions, the control automatically takes over as an upper voltage limit control, not affected by load current, to prevent damage to equipment close to the transformer. While the Block Raise contact prevents a raise operation, a Lower contact forces the tapchanger down if the primary voltage should subsequently rise.

Features

Block Raise and Block Lower voltage levels are set by accurately calibrated **BANDCENTER** and **BANDWIDTH** controls, similar to those found on LTC transformer controls.

BLOCK RAISE/LOWER and **LOWER** LEDs indicate backup control status.

Block Raise, Block Lower, Lower and Alarm contacts provide outputs to drive external components.

Inputs

Power: 90 to 140 V ac, 50/60 Hz, 2 W at 120 V ac

Voltage: Less than 0.2 VA burden at 120 V ac input

Front Panel Controls

BANDWIDTH VOLTS: An accurately calibrated dial adjusts the bandwidth between Block Raise and Block Lower from 6 V to 24 V for 120 V ac.

BANDCENTER VOLTS: An accurately calibrated dial adjusts the Bandcenter from 100 V rms to 140 V rms which allows the M-0329B to operate with most transformer controls.

TIME DELAY SECONDS: Adjustable from 1 to 30 seconds. If voltage remains above the maximum (Block Raise) voltage by the selected amount for longer than the time set on the timer delay control, the M-0329B will initiate a tapchanger operation to lower the voltage.

Selectable Deadband: The deadband is the voltage range above the Block Raise Level where no tap changer operation takes place. In the M-0329B, it is selectable as 1, 2, 3, or 4 V rms. Measured voltages above the Block Raise Level plus the deadband will cause the control to immediately issue a Lower command.

Terminals: Barrier Strip with 8 to 32 screws

LED Indicators

The **BLOCK RAISE/LOWER** LED will light to indicate when the voltage is outside the band.

The **LOWER** LED will light when the voltage exceeds the Block Raise level for an adjustable time period.

Output Contacts

Output Contacts: Contacts are rated at 2 A at 120 V ac.

Blocking Contacts: Contacts will operate within 0.2 seconds after a voltage excursion to prevent the transformer control from causing another tapchange.

Alarm Contacts: After a fixed 3 minute time delay, if the voltage excursion is still present, the alarm is activated to indicate control failure.

Environmental

Temperature Range: Operates within $\pm 1\%$ voltage accuracy as per the following:

IEC 68-2-1 -40°C 96 hour duration

IEC 68-2-2 $+80^{\circ}\text{C}$ 96 hour duration

IEC 68-2-3 $+40^{\circ}\text{C}$ 93% RH 96 hour duration

Fungus Resistance: A conformal printed circuit board coating inhibits fungus growth.

Transient Protection

Input and output circuits are protected against system transients. The M-0329B will pass all the requirements of ANSI/IEEE C37.90.1-1989, which defines oscillatory and fast transient surge withstand capability. All inputs and outputs will withstand 1500 V ac to chassis or instrument ground for one minute. Voltage inputs are electrically isolated from each other, from other circuits, and from ground.

All faces of the relay, with the chassis solidly grounded, have been exposed to Radio Frequency Immunity testing and have successfully passed with a field intensity of 20 V per meter at typical utility frequencies of 144 MHz, 438 MHz, and at 450 MHz.

Physical

Size: 5-3/4" high x 8-3/4" wide x 3-1/2" deep (14.6 cm x 22.2 cm x 8.9 cm)

Approximate Weight: 3 lbs (1.4 kg)

Approximate Shipping Weight: 5 lbs (2.3 kg)

Patent & Warranty

The M-0329B LTC Backup Control is covered by a five year warranty from date of shipment.

Specification subject to change without notice.



BECKWITH ELECTRIC CO., INC.

6190 - 118th Avenue North • Largo, Florida 33773-3724 U.S.A.

PHONE (727)544-2326 • FAX (727)546-0121

E-MAIL marketing@beckwithelectric.com

WEBPAGE www.beckwithelectric.com

WARNING

DANGEROUS VOLTAGES, capable of causing death or serious injury, are present on the external terminals and inside the equipment. Use extreme caution and follow all safety rules when handling, testing or adjusting the equipment. However, these internal voltage levels are no greater than the voltages applied to the external terminals.

DANGER! HIGH VOLTAGE



- This sign warns that the area is connected to a dangerous high voltage, and you must never touch it.

PERSONNEL SAFETY PRECAUTIONS

The following general rules and other specific warnings throughout the manual must be followed during application, test or repair of this equipment. Failure to do so will violate standards for safety in the design, manufacture, and intended use of the product. Qualified personnel should be the only ones who operate and maintain this equipment. Beckwith Electric Co., Inc. assumes no liability for the customer's failure to comply with these requirements.



- This sign means that you should refer to the corresponding section of the operation manual for important information before proceeding.



Always Ground the Equipment

To avoid possible shock hazard, the chassis must be connected to an electrical ground. When servicing equipment in a test area, the Protective Earth Terminal must be attached to a separate ground securely by use of a tool, since it is not grounded by external connectors.

Do NOT operate in an explosive environment

Do not operate this equipment in the presence of flammable or explosive gases or fumes. To do so would risk a possible fire or explosion.

Keep away from live circuits

Operating personnel must not remove the cover or expose the printed circuit board while power is applied. In no case may components be replaced with power applied. In some instances, dangerous voltages may exist even when power is disconnected. To avoid electrical shock, always disconnect power and discharge circuits before working on the unit.

Exercise care during installation, operation, & maintenance procedures

The equipment described in this manual contains voltages high enough to cause serious injury or death. Only qualified personnel should install, operate, test, and maintain this equipment. Be sure that all personnel safety procedures are carefully followed. Exercise due care when operating or servicing alone.

Do not modify equipment

Do not perform any unauthorized modifications on this instrument. Return of the unit to a Beckwith Electric repair facility is preferred. If authorized modifications are to be attempted, be sure to follow replacement procedures carefully to assure that safety features are maintained.

PRODUCT CAUTIONS

Before attempting any test, calibration, or maintenance procedure, personnel must be completely familiar with the particular circuitry of this unit, and have an adequate understanding of field effect devices. If a component is found to be defective, always follow replacement procedures carefully to that assure safety features are maintained. Always replace components with those of equal or better quality as shown in the Parts List of the Instruction Book.

Avoid static charge

This unit contains MOS circuitry, which can be damaged by improper test or rework procedures. Care should be taken to avoid static charge on work surfaces and service personnel.

Use caution when measuring resistances

Any attempt to measure resistances between points on the printed circuit board, unless otherwise noted in the Instruction Book, is likely to cause damage to the unit.

TABLE OF CONTENTS

M-0329B LTC Backup Control

Instruction Book

1.1	Introduction	1
	<i>Figure 1 Setpoint Voltage Levels</i>	1
2.1	Installation	2
	<i>Figure 2 Mounting and Outline Dimensions</i>	3
3.1	Terminal Block Connections	4
	<i>Figure 3 Wire Terminations for External Connections As Required for UL Listing</i>	4
	<i>Figure 4 External Connections</i>	4
4.1	Application	5
	<i>Figure 5 Power and Voltage Input Connections</i>	5
	<i>Figure 6 M-0329B Interconnections with Beckwith Tapchanger Controls and Regulator</i>	5
	<i>Table 1 TCC Connections</i>	6
	<i>Figure 7 Interconnections for use with Centrifugal-type Capacitor Drive Motors</i>	7
5.1	Adjustment	8
6.1	Theory of Operation	8
	Power Supply	8
	AC/DC Converter	8
	Level Detectors	8
	Power Supply Monitor	8
	Lower Time Delay	9
	Alarm	9
	Selectable Deadband	9
	<i>Table 2 Switch Position Settings</i>	9
	<i>Figure 8 Schematic</i>	10
	<i>Figure 9 Block Diagram</i>	12
7.1	Maintenance	13

8.1	Test Procedure	14
	Equipment Required	14
	<i>Figure 10 Test Setup</i>	14
	Test Setup	15
	Procedure for Determining Voltage Bandcenter	15
	Test Procedure	15
	Bandcenter Test	15
	Bandwidth Test	15
	Deadband (Block Raise to Block Lower) Test	15
	Lower Timer Delay Test	15
	Fixed Alarm Time Delay Test	15
	Removing the Printed Circuit Board	16
	Component Replacement Procedure	16
9.1	Typical Voltages	16
	<i>Table 3 Typical Voltages</i>	16
10.1	Typical Resistances	17
	<i>Table 4 Typical Resistances</i>	17
	<i>Figure 11 Component Location</i>	18
11.1	Calibration	19
	Parts List	20

1.1 Introduction

Defective tapchanger controls can create either too high or too low a voltage along the line, possibly damaging customer's motors, computers or televisions. Even when the control is operating properly, customers close to the transformer may receive dangerously high voltage as the line drop compensator attempts to maintain a constant voltage under heavy load at a central point on the distribution line. The Beckwith M-0329B LTC Backup Control can be installed as a solution to both of these problems.

Designed to replace the Beckwith M-0029 LTC Control Backup Relay as well as the M-0145 First Customer Protector, the single-phase, solid-state M-0329B has three main functions:

1. Prevent a defective LTC tapchanger control from running the voltage outside the upper and lower voltage limits.
2. Prevent the line drop compensator from raising the voltage too high under full load or overload conditions.
3. Lower the voltage if the regulated voltage goes above the Block Raise setpoint by a fixed bandwidth, as shown in Figure 1.

The Block Raise and Block Lower voltage levels are set by accurately calibrated dials, labeled **BANDCENTER** and **BANDWIDTH**, similar to those found on LTC transformer controls.

The amount of Deadband between the Block Raise and the Lower levels can be selected by the customer, using a switch on the side of the unit. The **BANDCENTER** dial has settings from 100 V rms to 140 V rms that allow the relay to match any transformer control.

Above the Block Raise level, the relay will detect voltage above the Lower setpoint. This point is at a fixed level above the Block Raise, and will initiate a lower tapchange operation if exceeded for an adjustable amount of time (1 to 30 sec) as set on the **TIME DELAY** control.

Blocking contacts on the M-0329B will operate within 0.2 seconds after a voltage excursion to prevent the defective transformer control from causing another tapchange. After a fixed 3 minute time delay, if the voltage excursion is still present, the **ALARM** contact is activated to indicate control failure.

Under full or overload conditions, the M-0329B automatically takes over as an upper voltage limit control, not affected by load current, to prevent damage to equipment close to the transformer. While the Block Raise contact prevents a raise operation, a Lower contact forces the tapchanger down if the primary voltage should subsequently rise.

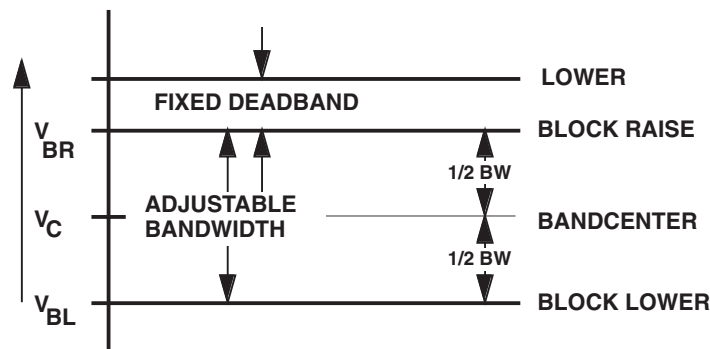

Figure 1 Setpoint Voltage Levels

2.1 Installation

The mounting and outline dimensions are shown in Figure 2, and the external connections in Figure 4.

■ **NOTE:** TB refers to Terminal Block numbers shown in Figure 4 External Connections.

The M-0329B can be connected as a two-terminal device, by paralleling the Power Input (TB1-1 to TB1-2) and the Voltage (Sensing) Input (TB1-3 to TB1-4). With this connection, the **BANDCENTER** and the **BANDWIDTH** controls can be set so that an upper voltage and a lower voltage limit are established at the desired levels. The M-0329B will block any further tapchanger raise operations when the regulated voltage exceeds the upper voltage limit. Also, if the voltage drops below the lower limit, the M-0329B will block any further lower operations. Additionally, if the voltage level increases above the upper limit (Block Raise) the M-0329B will lower the voltage, protecting customers from excessively high voltage levels. The M-0329B also provides the First Customer Protection function that previously required a separate relay. If the LDC raises the local voltage due to heavy load current, the M-0329B will protect nearby customers from high voltage, and will act as an LTC control around the upper voltage limit.

On controls where compensated voltage from the line drop compensator is available, the M-0329B can be connected as a four-wire device. The Power Input should be connected to a 120 V ac source and the Voltage Input is then connected to the LDC compensated voltage.

Since sudden changes in the transformer primary voltage may move the secondary voltage outside the range of the LTC control and the M-0329B, a 3 minute timer is provided to allow a normal control to correct the voltage. After 3 minutes of abnormal voltage, the M-0329B **ALARM** contact will indicate an abnormal condition. The **BLOCK RAISE/LOWER** LED will be on, the **ALARM** relay contacts TB1-14 to TB1-15 will be closed and TB1-15 to TB1-16 will be open. The **ALARM** contacts will also indicate an alarm condition if the AC power to the M-0329B fails.

The **ALARM** contacts should be used to alert system operators that a problem has occurred and that the LTC transformer or regulator is not operating. It must be recognized that the **ALARM** contacts may operate under conditions of heavy load using the two-wire connections and the line drop compensator.

The output blocking contacts should be connected in series with the raise and lower contacts from the LTC control. In some control circuits, a timing relay is used. There, the blocking contacts should be in series with the timing relay contacts. The blocking relay contacts should not be connected to drop out the motor starter relay once it is sealed in for a tapchange, since most tapchangers should not be stopped until the tapchange is completed. An exception to this is a spring-driven tapchanger that may be stopped at any time. Figure 6 shows the connections for using the M-0329B with most of the Beckwith Tapchanger and Regulator Controls.

When power is suddenly changed from raise to lower, motors with centrifugal starters will continue to run in the wrong direction without reversing. A defective control timer, for example, could lead to this type of runaway situation. Here, the M-0329B will open up the wrong connection if connected as described above. The circuit of Figure 7 may be used instead, where timer relay KX permits the motor to stop regardless of its direction. It is assumed that the motor will start in the right direction once it has stopped.

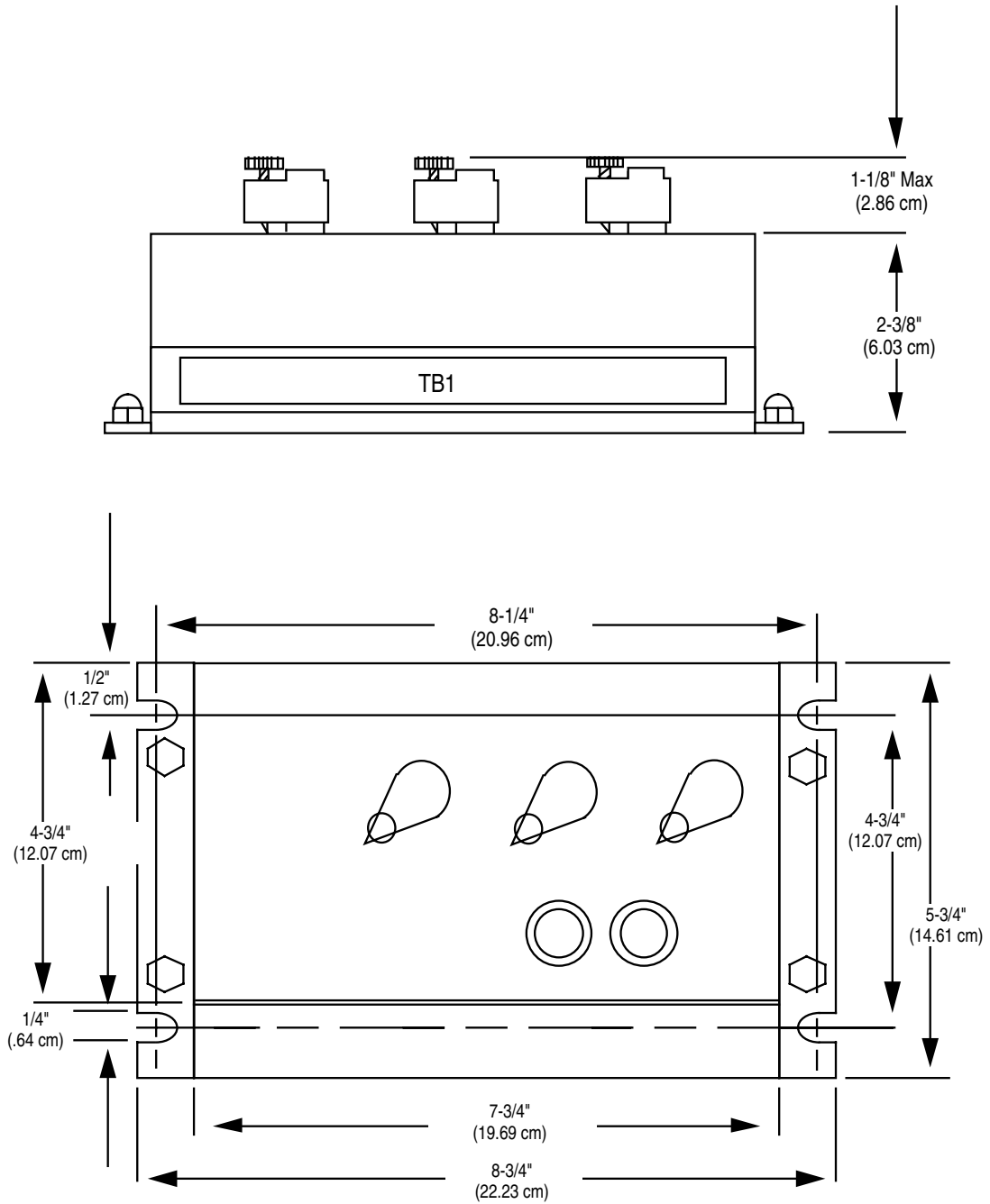

■ **NOTE:** Panel mount using four #10 bolts

Figure 2 Mounting and Outline Dimensions

3.1 Terminal Block Connections

The M-0329B LTC Backup Control is listed to UL Standards for Safety by Underwriters Laboratories Inc. (UL). To fulfill the UL requirements, terminal block connections must be made as illustrated in

the figure below. The wire should be No. 16 AWG inserted in an AMP #51864-1 (or equivalent) connector, and both screws tightened to 16 inch-pounds torque.

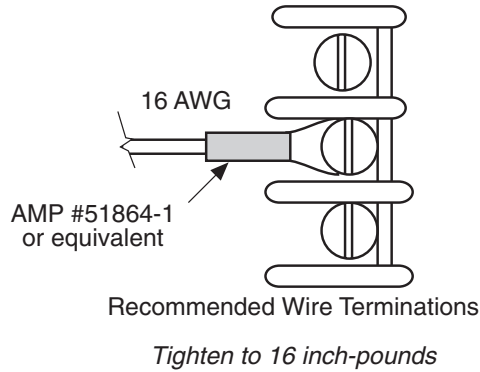
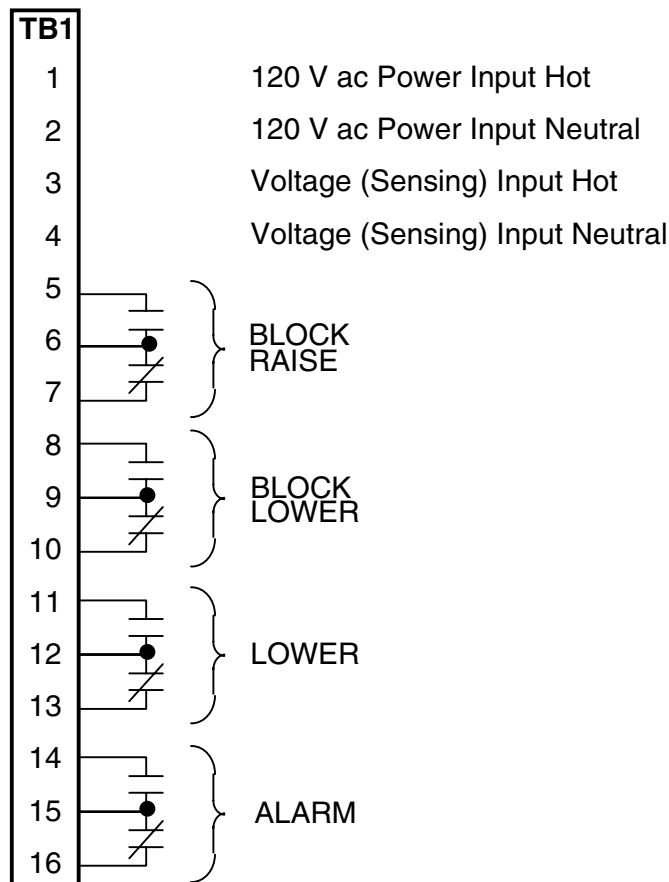

Figure 3 Wire Terminations for External Connections as Required for UL Listing



■ **NOTE:** All contacts are shown in the inactive (normal) condition, i.e. the output contact between TB1-14 and TB1-15 is open for the No Alarm condition and will close to indicate an Alarm Condition.

Figure 4 External Connections

4.1 Application

The M-0329B can be used in many applications not related to LTC backup for a very accurate overvoltage and/or undervoltage relay. The Block

Raise (**BLK R**) and the Block Lower (**BLK L**) outputs can be used as overvoltage and undervoltage outputs, respectively.

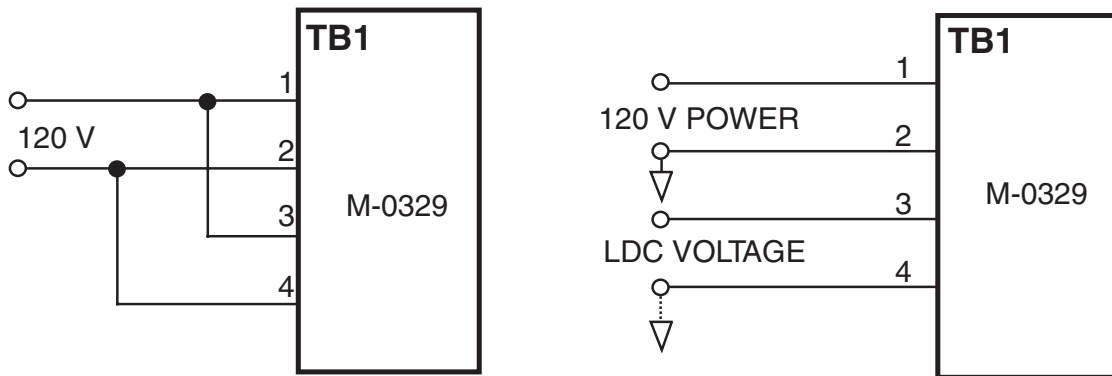
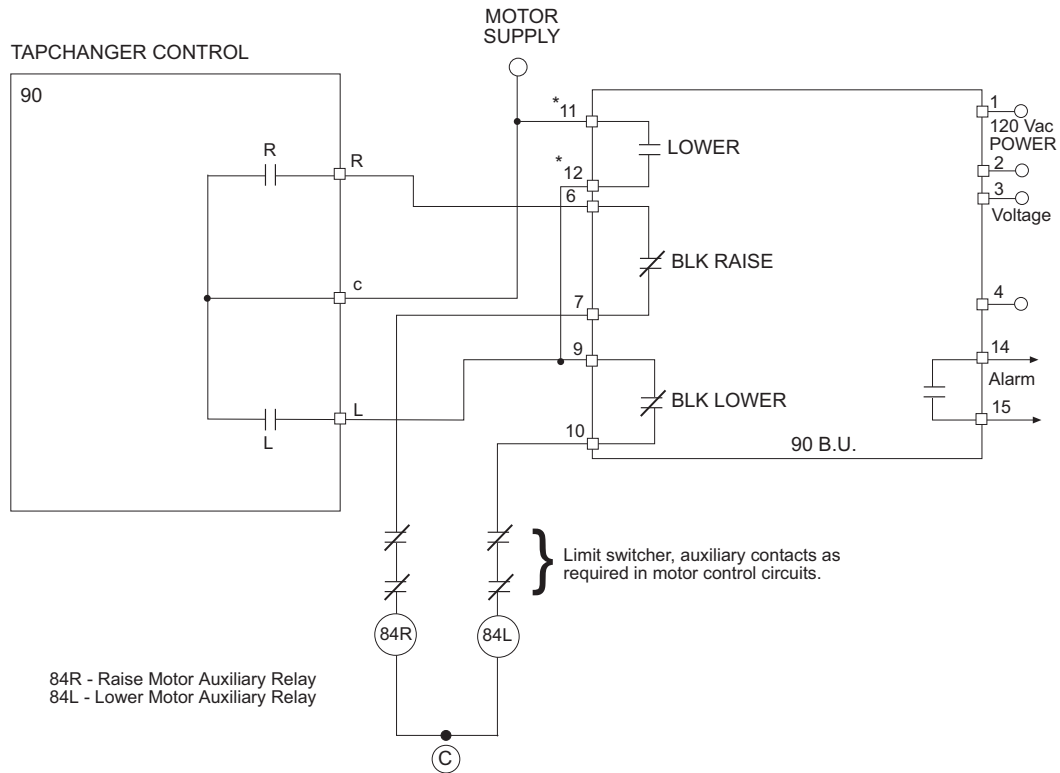

Figure 5 Power and Voltage Input Connections



■ **NOTE:** *If first customer protection is not required, delete these connections.

Figure 6 M-0329B Interconnections with Beckwith Tapchanger Controls and Regulator

TCC CONNECTIONS				
UNIT	TERMINAL NUMBERS			
	R	C	L	
M-0067/M-2067	7	8	9	
M-0271(TB1)/M-2271	5	9	6	
M-0270/M-2270	5	9	6	
M-0280(TB2)/M-2280 (TB3)	6	4	7	
M-0278(TB2)/M-2278(TB3)	10	9	11	
M-0293/M-2293 (TB1)	5	9	6	
M-0243/M-2293 (NN)	NN-27	NN-9	NN-28	
M-0323	L	J	C	
M-0324/M-2324	25	V2	23	
M-0338	10	9	11	
M-0339/M-2339(TB4)	10	9	11	
M-0345	2	V1	3	
M-0355/M-2355	R3	Vm	L3	
M-0357	E15	E2	E18	

Table 1 TCC Connections

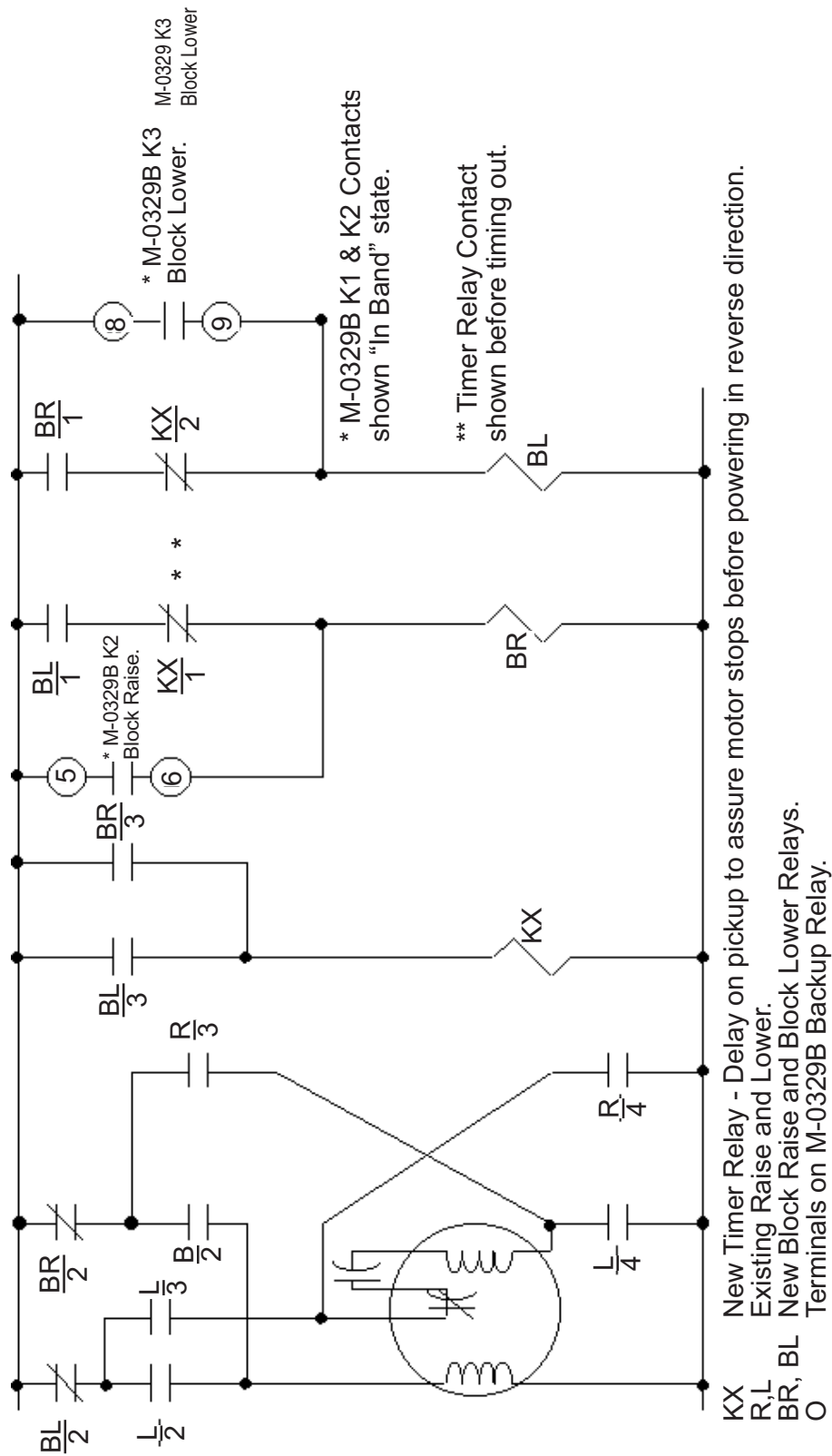

Figure 7 Interconnections for use with Centrifugal-Type Capacitor Drive Motors

5.1 Adjustment

Accurately calibrated dials, labeled **BANDCENTER** and **BANDWIDTH**, set the Block Raise and Block Lower voltage levels. The dials on the M-0329B cover are calibrated in volts for use with a 120 V ac nominal voltage.

The following equations will assist the user in choosing the correct setpoints for the M-0329B.

V_{BR} = the Upper Voltage Limit (Block Raise) desired.

V_{BL} = the Lower Voltage Limit (Block Lower) desired.

The Base Voltage is 120 V ac.

$$\text{The Bandcenter Voltage } V_C = \frac{V_{BR} + V_{BL}}{2} \quad (1)$$

$$\text{The Bandwidth } V_{BW} = V_{BR} - V_{BL} \quad (2)$$

6.1 Theory of Operation

Refer to Figure 8, Schematic and Figure 9, Block Diagram.

Power Supply

The Power Supply converts the 120 V ac power input to the dc voltages required for the M-0329B circuitry. Components C1 and RV1 are used to suppress transverse-mode transients on the input. RV2 and RV3 are common-mode suppressors that allow up to 1500 V rms common-mode voltage but will clip any transients above this level. T1 converts the 120 V ac input to 36 V ac, center-tapped at T1-4. T1 also employs a Faraday shield that isolates the secondary windings from common-mode transients on the primary.

Diodes CR1 through CR4 form a full-wave rectifier that produces +24 V dc and -24 V dc from the secondary of T1. Capacitors C2 and C3 filter the ac ripple off the +24 V dc; C7 smooths out the -24 V dc. VR1 is a zener diode that clips off, to a safe level, any transients that may remain on the +24 V dc, protecting U1 and U5.

U1 converts the +24 V dc to a precision +10.00 V dc reference voltage for use by the internal circuitry. The +V supply is a +15 V dc level formed by U5, R102, R103, C19 & C4. The -15 V is a zener diode supply using VR3 and dropping resistor R9.

AC/DC Converter

The Voltage Input, TB1-3 to TB1-4, is the voltage that the M-0329B will monitor to provide the voltage protection functions described previously. The input protection circuitry for the Sensing Input is the same used for the Power Input. Transformer T2 steps down the input level to a lower level used by the Ac/Dc Converter. U2-1, U2-7 and associated circuitry form a precision active full-wave rectifier/filter that converts the ac Sensing Input to a dc voltage that is proportional to the average voltage level of the Sensing Input. This dc level at U2-1 is offset by the **BANDCENTER** adjustment network, consisting of R3, R16, R17, R15 and R14; so that the voltage at U2-1 equals +5.0 V dc when the Sensing Input level is equal to the setting of the **BANDCENTER** dial. Any variation of the input level from the **BANDCENTER** setting will cause the U2-1 voltage to deviate from +5.0 V dc by approximately 0.072 V dc/%.

Level Detectors

The Level Detector circuits compare the dc voltage from U2-1 to dc levels set by the **BANDWIDTH** control. R21 and R4 are used in a voltage-divider circuit to establish the bandwidth. The voltage across R21 and R4 is centered around +5.00 V dc so that a symmetrical band is formed around the **BANDCENTER** setting. If the U2-1 voltage rises above the voltage at U2-9, the output at U2-8 goes high to block any further raise operations of the tapchanger. If the voltage drops below the level at U2-12, the voltage at U2-14 goes high, blocking any further lower operations of the LTC. When the U2-1 output voltage exceeds the level at U3-6, the voltage at U3-7 goes high, lighting the **LOWER** LED and initiating a lower operation. R23 through R28 provide a small amount of hysteresis at each of the voltage levels in order to avoid oscillations in the level detector outputs.

Power Supply Monitor

The Power Supply Monitor is used to delay the operation of the **BLK R**, **BLK L**, and **LOWER** relays for approximately 2 seconds when power is applied. This eliminates any relay chatter when the M-0329B is put in service. Also, this circuit monitors the level of the Power Input and disables the above relays if the voltage level is below 75 V ac.

Amplifier U3-1 and associated components form the voltage level detector that monitors the +24 V dc level. If the level is below 13.7 V dc, the output at U3-1 will be low, forcing the output at U4-10 low. This disables the three relay drive circuits for K1, K2, and K3. When the +24 V dc level exceeds 14.8 V dc, the output at U3-1 will be high, enabling the relay drive circuits.

Components R32 and C15 provide the Power Up delay. C15 is discharged when the power is off. When power is applied, C15 is charged from +V through R32. When the voltage on C15 reaches one half the +V level, the U4-10 output is enabled. If the voltage at U4-9 is also high, then the output at U4-10 will go high. This enables the other three U4 gates so that the level detector outputs are enabled to control the output relays.

Lower Time Delay

Op Amp U3-14 and associated components form an adjustable time delay for the **LOWER** relay operation. By adjusting the **TIME DELAY** control, a voltage level is established at the wiper of R5 which determines the length of the time delay. When the output at U4-11 goes high, C16 begins charging through R39. CR14 blocks charging current from flowing through R38. When the voltage at U3-12 reaches the level set by R5, the output at U3-14 goes high, turning on Q2 and energizing K1. R40 and R41 provide the positive feedback to prevent oscillations. The length of the time delay is determined by the setting of R5.

Alarm

The **ALARM** relay provides an indication that the M-0329B is in a blocking condition or that the power is off. Relay K4 is normally energized when there is no Alarm condition. When K4 is de-energized, an Alarm is generated by the closing of TB1-14 to TB1-15 and the opening of TB1-15 to TB1-16. Therefore, if power to the M-0329B is off, an Alarm is generated.

In the normal (No Alarm) condition, the output of U3-8 is high, turning on Q5 through R54 and CR22. This condition will remain as long as the outputs of U4-4 and U4-3 remain low. When either of these goes high, C17 is charged by this voltage through R50. After 3 minutes, the voltage on C17 will exceed the voltage established at U3-10, causing the output at U3-8 to go low, generating an Alarm.

Selectable Deadband

Switch S1 controls the deadband voltage selection. When position 1 is up and positions 2, 3, and 4 are down, the deadband selection is 1 V. When position 2 is up and positions 1, 3, and 4 are down, the deadband selection is 2 V. If more than one switch is in the “up” position, the control's operation and deadband setting will be unpredictable.

	Switch Position			
Deadband Setting	S1-1	S1-2	S1-3	S1-4
1V	Up	Down	Down	Down
2V	Down	Up	Down	Down
3V	Down	Down	Up	Down
4V	Down	Down	Down	Up

Table 2 Switch Position Settings

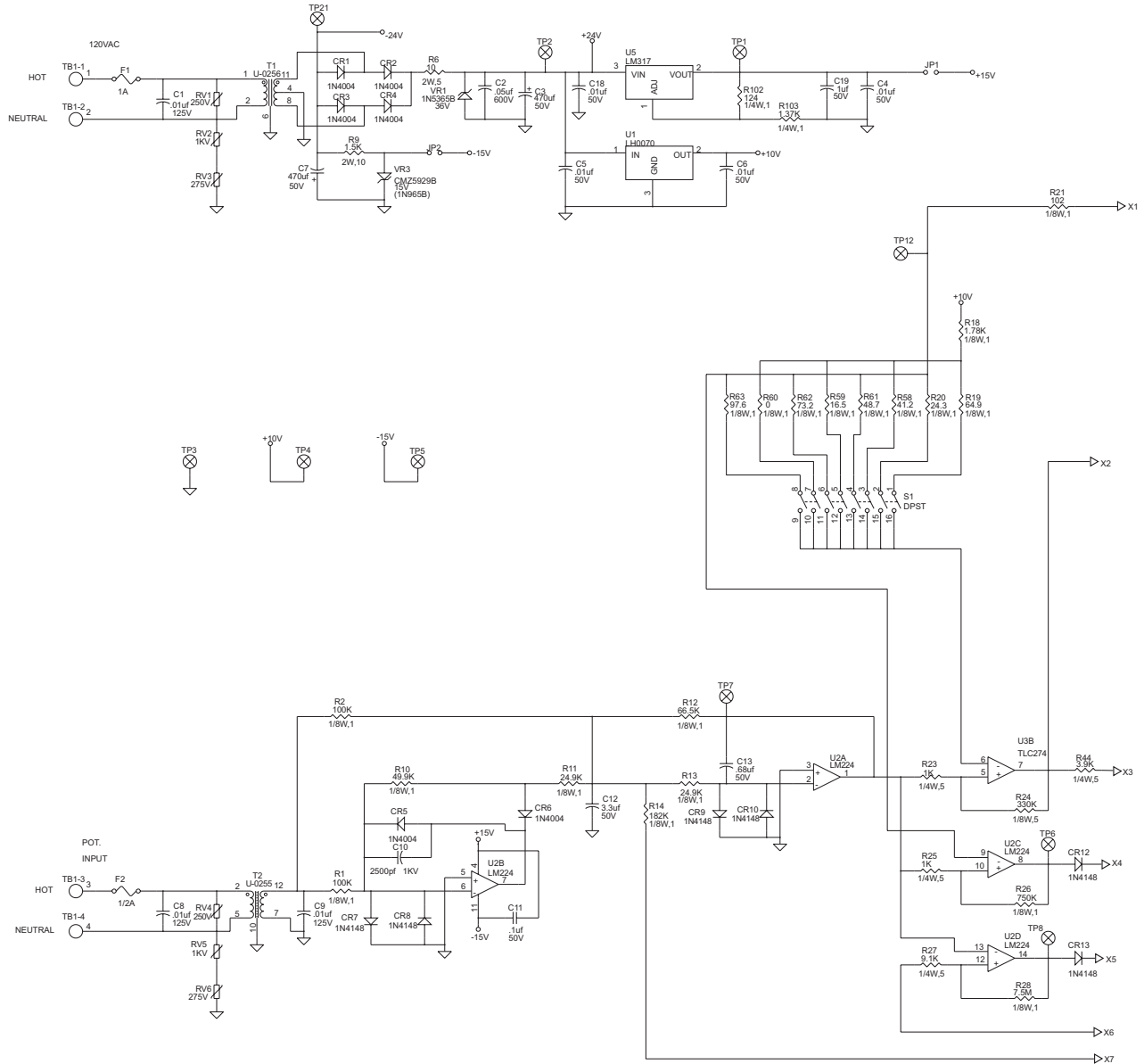
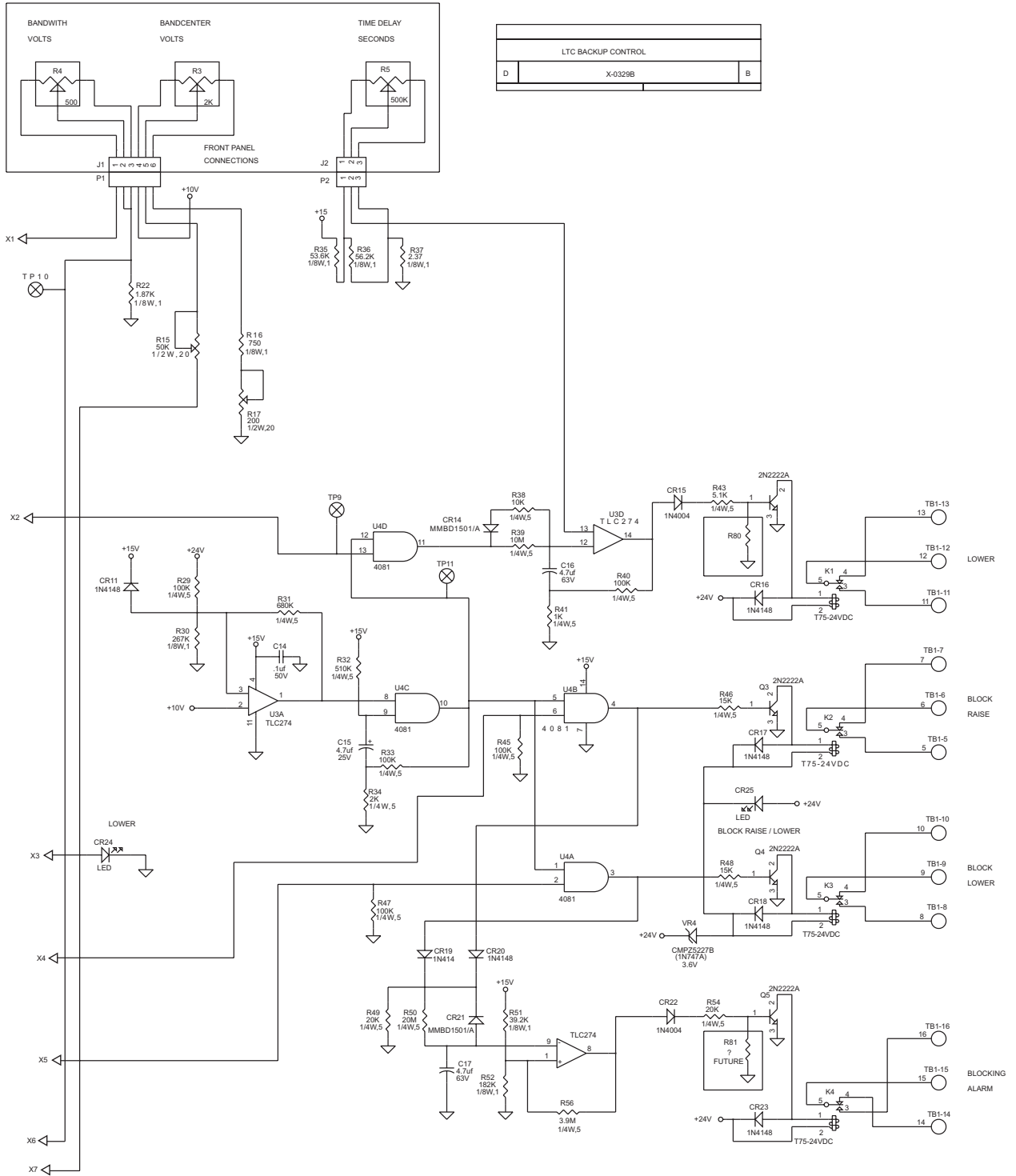

Figure 8 Schematic



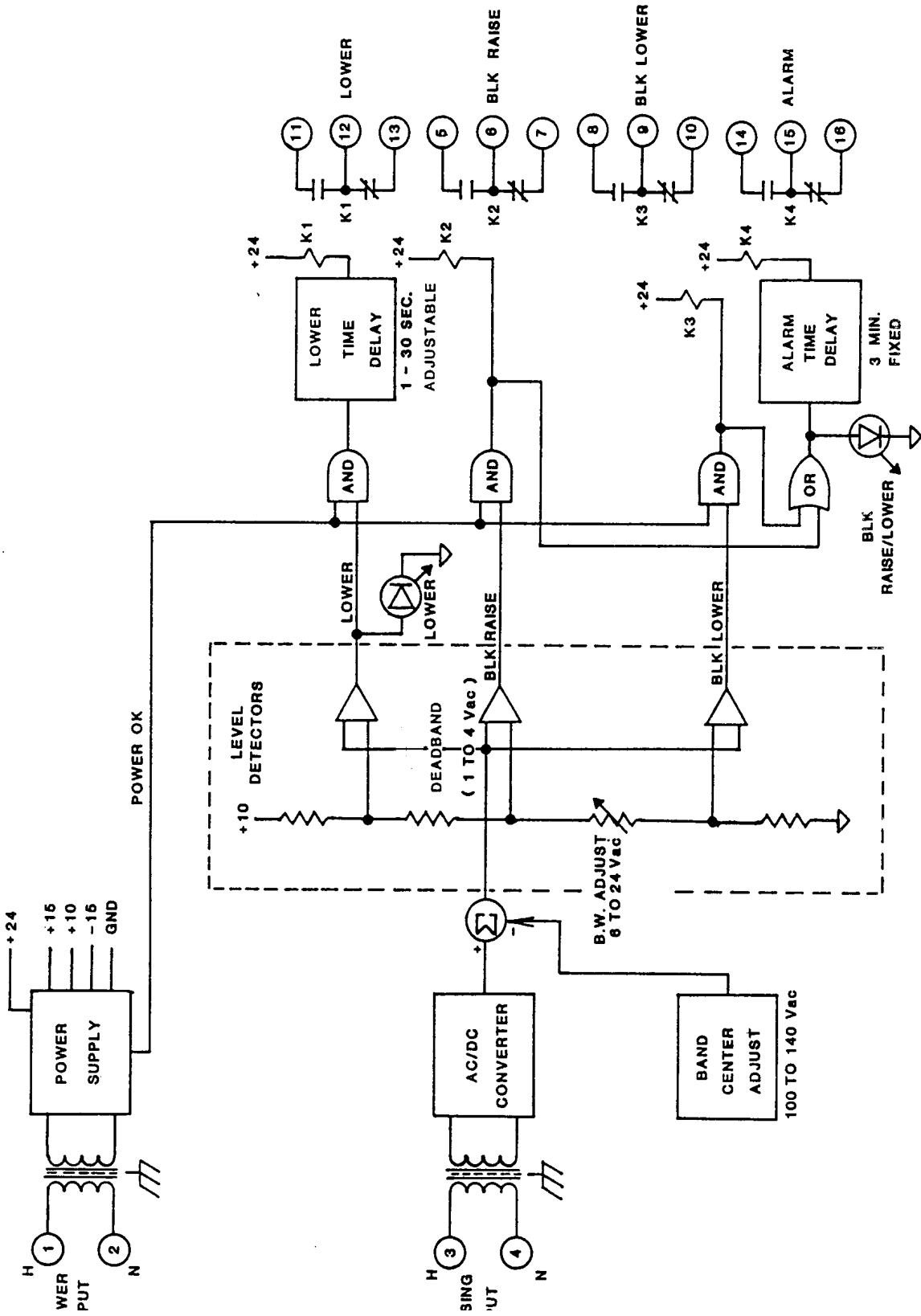

Figure 9 Block Diagram

7.1 Maintenance

Due to the extremely sophisticated nature of the circuitry in the M-0329B, field repair is not recommended. All units are fully calibrated at the factory prior to shipment; there is no need to recalibrate a unit prior to initial installation. Calibration is only required after a component is replaced. In the event that a unit does not operate properly, it should be established that the problem is caused by malfunction of a Beckwith unit and not caused by an external fault or wiring error. Once this is assured, the entire unit should be returned to Beckwith Electric. Pack the unit carefully (in the original carton if possible), assuring that there is adequate packing material to protect the contents.

■ **NOTE:** Any equipment returned for repair must be sent with transportation charges prepaid. The equipment must remain the property of the user. The warranty is void if the value of the unit is invoiced to Beckwith Electric at the time of return or if the unit is returned with transportation charges collect.

If under warranty, units will be repaired rapidly and returned at no cost and with return transportation paid if the fault is found to be due to workmanship or failure of material. If a unit is under warranty and express shipment for return of the repaired unit is requested, shipping charges will be billed at the current rate. If the fault is due to abuse or misuse, or if the unit is out of warranty, a modest charge will be made. Repair can normally be expected to take two weeks, plus shipping time. If faster service is required, it should be requested at the time of return.

■ **NOTE:** Units returned with only a blown fuse are not covered by warranty and a nominal repair charge will be made for replacement of the fuse. Please check the fuses before returning the M-0329B for repair in order to avoid unnecessary repair charges.

To help in analyzing the problem, a complete description of the malfunction and conditions leading to the failure should be included with the unit.

However, if you choose to repair the unit, it is necessary to be completely familiar with the circuitry involved, and have an adequate understanding of field effect devices. Be sure to carefully read the **WARNING** page at the beginning of this manual.

It is suggested that first a visual inspection be made for any component that does not appear normal or appears to have overheated. Analysis of the circuit will then often lead to the cause of the failure and components that need to be replaced.

If no obvious problems exist, it is suggested that the **TEST** and **CALIBRATION PROCEDURES** be followed until a portion of a circuit is detected which does not perform as expected or until a calibration point is found which will not meet requirements. These procedures should lead to a determination of the defective component.

8.1 Test Procedure

Please refer to the **WARNING** page at the beginning of this manual before proceeding.

Refer to Figure 10 for the test setup.

Equipment Required

1. A stable 60 Hz source with fixed 120 V rms and proper load regulation so that the amplitude does not change more than 0.05 V rms when the relays are energized or the functional indicator lamps are on.
2. A variac, 0 to 140 V adjustable transformer.
3. A high impedance true rms digital multimeter with an ac accuracy of at least $\pm 0.02\%$ of reading, Fluke 45 or equivalent.
4. Solder sucking syringe or solder wick.
5. Soldering iron - Weller Controlled Output Soldering Station Model MTCPL, 60 W, 120 V, 50/60 Hz or equivalent with grounded tip.
6. An accurate stopwatch.

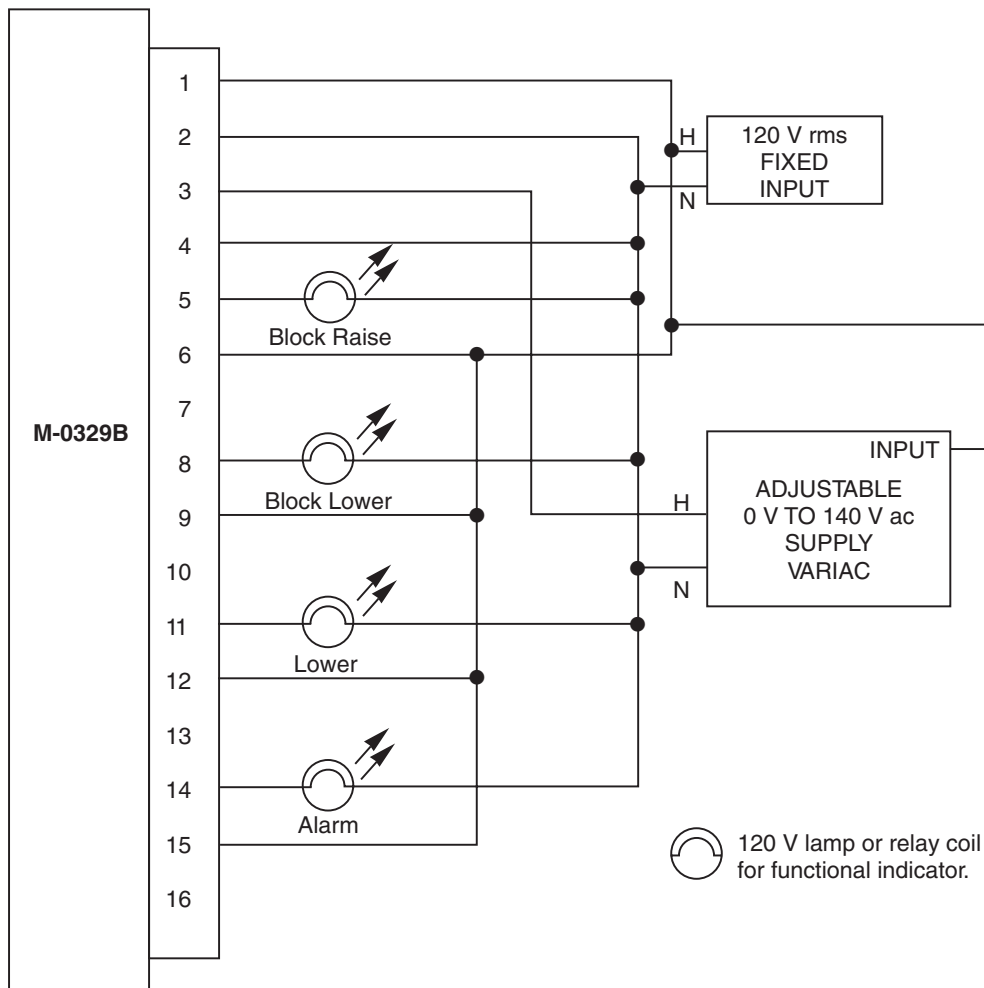

Figure 10 Test Setup

Test Setup

Make the electrical connections as required in Figure 10. The functional indicator lamps are suggested to facilitate testing and can be eliminated if other methods are used.

Procedure for Determining Voltage Bandcenter

When checking the voltage **BANDCENTER** settings, the exact voltage where the **BLOCK RAISE/LOWER** and **LOWER** LEDs light should be recorded. The voltage level Bandcenter is calculated as the average of these voltages:

$$\text{Bandcenter Voltage} = \frac{V_{\text{Block Lower}} + V_{\text{Block Raise}}}{2}$$

The voltage at which the **BLOCK RAISE/LOWER** and **LOWER** LEDs, and the functional indicators shown in Figure 9 turn on should be recorded in all cases. The band-edge hysteresis causes the LEDs to turn on and off at slightly different voltages.

Test Procedure

Refer to Figure 1 for a diagram depicting Bandcenter, Bandwidth and Fixed Deadband voltage levels.

Bandcenter Test

1. Set the **BANDWIDTH** dial at 6 V.
2. Set the **BANDCENTER** dial at 120 V and check the actual Bandcenter by varying the Voltage Input at TB1-3 to TB1-4. Be sure to position the **BANDCENTER** dial pointer exactly in the center of the line on the dial grid.
3. Repeat Step 2 at 108 V rms and 132 V rms.
4. The calculated values should be within ± 1 V rms of the dial setting.

Bandwidth Test

1. The **BANDWIDTH** dial was previously set at 6 V Bandwidth. Check the actual Bandwidth by calculating the difference between $V_{\text{Block Lower}}$ and $V_{\text{Block Raise}}$.
2. Repeat Step 1 at 12 V Bandwidth, 18 V Bandwidth, and 24 V Bandwidth.
3. The Bandwidth should be within $\pm 10\%$ of setting.

Deadband (Block Raise to Block Lower) Test

1. Return the **BANDWIDTH** dial to 6 V.
2. Check the actual Bandwidth between the $V_{\text{Block Raise}}$ and $V_{\text{Block Lower}}$ by recording the voltage at which the **LOWER** LED turns on.
3. Reduce the input voltage until the Block Raise functional indicator turns on.
4. Calculate the Deadband = $V_{\text{Block Lower}} - V_{\text{Block Raise}}$. The setting is selectable by the customer.
5. The calculated Deadband should be within $\pm 3\%$ of the setting.

Lower Timer Delay Test

1. Set the **TIME DELAY** potentiometer to 1 second (minimum).
2. Increase the input voltage until the **LOWER** LED lights. Using a stopwatch, measure the time required for the **LOWER** relay to pick up.
3. Adjust the **TIME DELAY** potentiometer to 30 seconds (maximum) and repeat Step 2.
4. The measured times should be within $\pm 10\%$ of setting.

Fixed Alarm Time Delay Test

1. Set the **BANDCENTER** control to 120 V rms.
2. Set the **BANDWIDTH** control to 6 V.
3. Decrease the input voltage until the **BLOCK RAISE/LOWER** LED lights. Using a stopwatch, measure the time required for the **ALARM** relay to de-energize.
4. The measured time should be 180 seconds $\pm 20\%$.
5. Return the input voltage to 120 V rms or until the **BLOCK RAISE/LOWER** LED turns off.
6. Increase the voltage potential until the **BLOCK RAISE/LOWER** LED lights. Measure the time required for the **ALARM** relay to de-energize.
7. Remove the 120 V ac power source from the M-0329B. The **ALARM** relay should de-energize without a time delay.

Removing the Printed Circuit Board

1. Remove the cover by loosening the four acorn nuts.
2. Remove the four screws that hold the transformers to the base plate.
3. Remove the two screws that hold the printed circuit board to the base plate.
4. The board can now be carefully removed by holding the transformers to avoid breaking the leads.
5. Visually inspect the board for any component which does not appear normal or appears to have overheated. This can often lead to finding the cause of the trouble and the component that needs to be replaced.

2. Remove the old component and discard.
3. Remove the excess solder using the solder syringe or wick, leaving the hole or pad clear to facilitate insertion of the new component.

▲ CAUTION: Do not attempt to melt the solder and push the new component through the hole as the leads are likely to catch the edge of the foil and lift it off of the board.

▲ CAUTION: If the M-0329B fails to operate properly and you choose to repair the unit, it is necessary to be completely familiar with the specific circuitry involved and have an adequate understanding of field effect devices.

Component Replacement Procedure

1. The M-0329B printed circuit board is coated with a moisture-resistant, conformal coating. If a component needs to be changed, carefully scrape away the coating surrounding the component using a small, sharp knife, being careful not to damage the foil on the printed circuit board.

9.1 Typical Voltages

Conditions

1. Power and Voltage Inputs are 120 V rms, 60 Hz.
2. Measurements are made with a high impedance true rms digital multimeter, Fluke 45 or equivalent.
3. Readings are made with the reference at Test Point 3 (TP3), as shown in Figure 11, Component Location.

Location of Test Points	Reading	Type of Waveform
TP1	15 V \pm 0.8	DC
TP2	22 V \pm 2	DC \leq 1 V _{P-P}
TP4	10 V \pm .02	DC
TP5	- 15 V \pm 0.8	DC
TP6	15 V \pm 0.8	DC
TP9	14 V \pm 0.5	DC
C7(-)	- 24 V \pm 2	DC \leq 1 V _{P-P}

Table 3 Typical Voltages

10.1 Typical Resistances

Conditions

1. All terminals are open circuited.
2. Measurements are made with a Fluke 45 digital multimeter.

Location of (-) Lead	Location of (+) Lead	Scale	Approximate Reading
TB1-1	TB1-2	200 Ω	115 Ω
TB1-3	TB1-4	20 K	2.17 K
TB1-5	TB1-6	20 M	00
TB1-6	TB1-7	20 Ω	.04 Ω
TB1-8	TB1-9	20 M	00
TB1-9	TB1-10	20 Ω	.03 Ω
TB1-11	TB1-12	20 M	00
TB1-12	TB1-13	20 Ω	.03 Ω
TB1-14	TB1-15	20 Ω	.03 Ω
TB1-15	TB1-16	20 M	00

Table 4 Typical Resistances

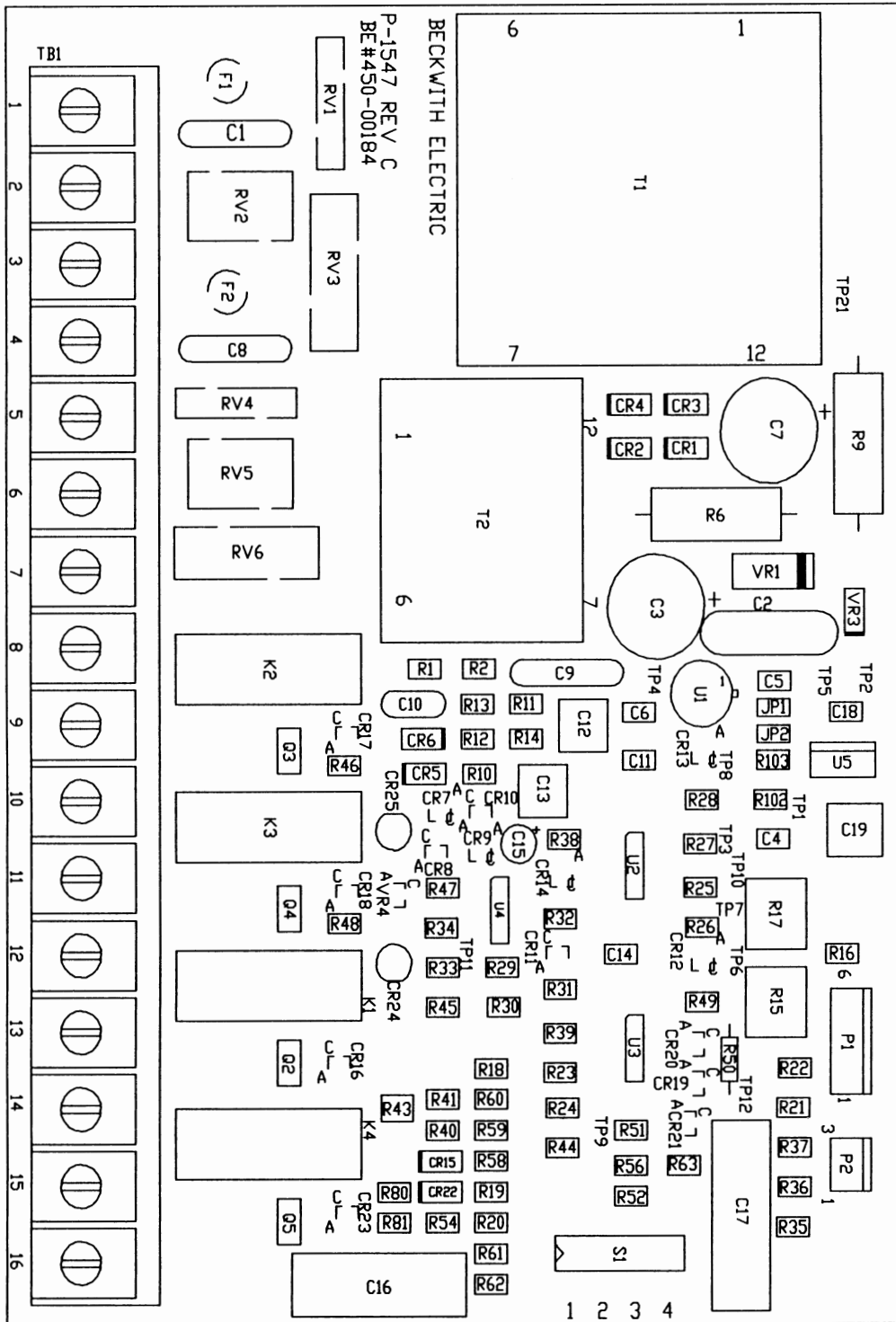

Figure 11 Component Location

11.1 Calibration

■ **NOTE:** The M-0329B has been fully calibrated at the factory prior to shipment. There is no need to recalibrate the unit before initial installation. Further calibration is only necessary if a component was changed during a repair procedure.

Bandcenter and Bandwidth

The **BANDCENTER** and **BANDWIDTH** dials are calibrated by adjusting the position of the knob on the potentiometer shaft. Initially, the knob should be turned to the full counterclockwise position and adjusted so that the pointer is aligned with the small dot to the left of the minimum scale setting. Further adjustments (if necessary) should be made at approximately half scale.

Bandcenter

1. Set the **BANDCENTER** control to the maximum scale 140 V center.
2. Adjust R15 until the measured Bandcenter is 140 V rms.
3. Set the **BANDCENTER** control to the minimum scale 100 V center.
4. Adjust R17 until the measured Bandcenter is 100 V rms.
5. Repeat Steps 1 through 4 until both the minimum and maximum are calibrated to within ± 0.5 V rms.
6. Measure the voltage Bandcenter at the 120 V rms setting. The Bandcenter should be 120 V rms ± 0.5 V.
7. If the 120 V rms setting is not within specifications, repeat Steps 1 through 6 at the 102 V rms setting and the 138 V rms setting.

Bandwidth

1. Set the **BANDWIDTH** dial to 12 V.
2. Slowly raise the voltage input until the **BLOCK RAISE** relay energizes. Note the voltage (V_{BR}).
3. Slowly lower the voltage until the **BLOCK LOWER** relay energizes. Note the voltage (V_{BL}).
4. Calculate the bandwidth ($V_{BR} - V_{BL}$) by taking the difference between the voltage recorded in step 2 and step 3.
5. The calculated bandwidth at 12 V should equal 12 V rms ± 0.8 V rms for a 120 V unit. If out of specification, adjust the **BANDWIDTH** dial on the shaft until the proper reading is acquired.
6. Adjust the **BANDWIDTH** dial to 18 V, and measure and record the bandwidth as in steps 2 through 3. The calculated bandwidth should equal 18 V rms ± 0.9 V rms for a 120 V unit.
7. Adjust the **BANDWIDTH** dial to 24 V, and measure and record the bandwidth as in steps 2 through 3. The calculated bandwidth should equal 24 V rms ± 1.2 V rms for a 120 V unit.
8. Adjust the **BANDWIDTH** dial to 6 V, and measure and record the bandwidth as in steps 2 through 3. The calculated bandwidth should equal 6 V rms ± 1.0 V rms for a 120 V unit.
9. Reset the **BANDWIDTH** dial to desired setting.

PARTS LIST

M-0329B LTC Backup Control

This list includes all electrical and mechanical parts which could conceivably either require replacement or be lost. The **COMPONENT DESIGNATION** is the same as that appearing on schematics or referred to in Instruction Books.

The **BECO NUMBER** refers to an index maintained by the company. This lists the currently available device which may be substituted even though the device originally supplied is obsolete and no longer available. Parts marked by an asterisk* are not available from other sources. Either the original component or a current substitute will be carried in stock by Beckwith Electric.

Parts not marked with an asterisk are normally available from an electronics components house. Those parts or a current substitute will normally be available from Beckwith Electric stock.

In either case, when parts are ordered from Beckwith Electric, we will be responsible for supplying the current replacement in the shortest possible time.

Sufficient detailed description is also given to permit purchasing from an electronics parts house, providing the part is of equal or better quality to insure reliable operation. This may require some interpretation of specifications which may be avoided by direct purchase from Beckwith Electric using the **BECO NUMBER**.

Note that in a few instances, components are selected in final test. Procedures described in the **TEST PROCEDURES** Section must be followed in replacing these components.

All resistors are 1/2 W unless noted.

COMPONENT DESIGNATION	BECO NUMBER	DESCRIPTION
C1,C8,C9	000-00948	Capacitor, Ceramic Disc, 0.01 μ F, \pm 20%,1 kV
C2	000-00905	Capacitor, Ceramic Disc, 0.05 μ F +80/-20%, 600 V
C3,C7	000-00643	Capacitor, Electrolytic, 470 μ F, 50 V
C4-C6, C18	000-00978	Capacitor, SMT, Ceramic, 0.01 μ F, 50 V
C10	000-00931	Capacitor, Ceramic Disc, 2500 pf \pm 20%,1 kV
C11, C14	000-00977	Capacitor, SMT, Ceramic, 0.1 μ F, 50 V, \pm 20%.
C12	010-00454	Capacitor, Polyester, 3.3 μ F \pm 10%, 50 V
C13	010-00842	Capacitor, Polyester, 0.68 μ F \pm 5%, 50 V
C15	000-00555	Capacitor, Tantalum, 4.7 μ F \pm 20%, 25 V
C16,C17	010-00459	Capacitor, Polycarbonate, 4.7 μ F \pm 10%, 63 V
C19	000-00987	Capacitor, SMT, 1 μ F , 50 V, \pm 10%.

COMPONENT DESIGNATION	BECO NUMBER	DESCRIPTION
CR1-CR6,CR15,CR22	400-00271	Diode, IN4004, SMT
CR7-CR13,CR16-CR20 CR23	400-00264	Diode, MMBD4148, SMT
CR14,CR21	400-00279	Diode, MMBD 1501/A, SMT
CR24,CR25	400-00722	Diode, Light Emitting
F1	420-00719	Fuse, 1 A
F2	420-00725	Fuse, 1/2 A
J1	030-00015	Contact Housing, 6-position
K1-K4	431-00099	Relay, SPDT, 24 V dc
P1	030-00202	Header, 6-Position
P2	030-00203	Header, 3-Position
Q2-Q5	400-00774	Transistor, NPN, 2N2222A, SMT
R1,R2	188-01003	Resistor, 100 K \pm 1%, 1/8 W
R3	360-00120	Potentiometer, 2 K \pm 5%
R4	360-00121	Potentiometer, 500 Ω \pm 5%
R5	360-00124	Potentiometer, 500 K
R6	240-00100	Resistor, Carbon, 10 Ω \pm 10%, 2 W
R9	240-00152	Resistor, Carbon, 1.5 K \pm 10%, 2 W
R10	188-04992	Resistor, 49.9 K \pm 1%, 1/8 W, SMT
R11,R13	188-02492	Resistor, 24.9 K \pm 1%, 1/8 W, SMT
R12	188-06652	Resistor, 66.5 K \pm 1%, 1/8 W, SMT
R14, R52	188-01823	Resistor, 182 K \pm 1%, 1/8 W, SMT

COMPONENT DESIGNATION	BECO NUMBER	DESCRIPTION
R15	360-00038	Potentiometer, 50 K
R16	188-07500	Resistor, 750 \pm 1%, 1/8 W, SMT
R17	360-00034	Potentiometer, 200 Ω
R18	188-01781	Resistor, 1.78 K \pm 1%, 1/8 W, SMT
R19	188-064R9	Resistor, 64,9 \pm 1%, 1/8 W, SMT
R20	188-024R3	Resistor, 24.3 \pm 1%, 1/8 W, SMT
R21	188-01020	Resistor, 102 Ω \pm 1%, 1/8 W, SMT
R22	188-01871	Resistor, 1.87 K \pm 1%, 1/8 W, SMT
R23,R25,R41	340-00054	Resistor, 1 K \pm 5%, 1/4 W, SMT
R24	340-00078	Resistor, 137 K \pm 1%, 1/8 W, SMT
R26	188-07503	Resistor, 750 K \pm 1%, 1/8 W, SMT
R27	180-00912	Resistor, Carbon, 9.1K \pm 5%, 1/4 W, SMT
R28	340-00106	Resistor, 7.5 M \pm 1%, 1/8 W, SMT
R29,R33,R40,R45,R47	340-00056	Resistor, 100 K \pm 5%, 1/4 W, SMT
R30	188-02673	Resistor, 267 K \pm 1%, 1/8 W, SMT
R31	185-00684	Resistor, 680 K \pm 5%, 1/4 W, SMT
R32	185-00514	Resistor, 510 K \pm 5%, 1/4 W, SMT
R34	185-00202	Resistor, 2 K \pm 5%, 1/4 W, SMT
R35	188-05362	Resistor, 53.6 K \pm 1%, 1/8 W, SMT
R36	188-05622	Resistor, 56.2 K \pm 1%, 1/8 W, SMT
R37	188-02371	Resistor, 2.37 K \pm 1%, 1/8 W, SMT
R38	340-00051	Resistor, 10 K \pm 5%, 1/4 W, SMT
R39	185-00106	Resistor, 10 M \pm 5%, 1/4 W, SMT
R43	340-00065	
R44	185-00392	Resistor, 3.9 K \pm 5%, 1/4 W, SMT
R46,R48	185-00153	Resistor, 15 K \pm 5%, 1/4 W, SMT

COMPONENT DESIGNATION	BECO NUMBER	DESCRIPTION
R49,R54	185-00203	Resistor, 20 K \pm 5%, 1/4 W, SMT
R50	180-00206	Resistor, 20 M \pm 5%, 1/4 W, SMT
R51	188-03922	Resistor, 33.2 K \pm 1%, 1/8 W, SMT
R56	185-00395	Resistor, 3.9 M, \pm 5%, 1/4 W, SMT
R58	188-042R2	Resistor, 41.2 \pm 1%, 1/8 W, SMT
R59	188-016R5	Resistor, 16.5 \pm 1%, 1/8 W, SMT
R60	340-00107	Resistor 0 ohm jumper, 1/8 W, SMT
R61	188-048R7	Resistor, 48.7 \pm 1%, 1/8 W, SMT
R62	188-073R2	Resistor, 73.2 \pm 1%, 1/8 W, SMT
R63	188-097R6	Resistor, 97.6, \pm 1%, 1/8 W, SMT
R102	187-01240	Resistor 124 \pm 1%, 1/4 W, SMT
R103	187-01371	Resistor 1.37 K \pm 1%, 1/4 W, SMT
RV1, RV4	400-00724	Varistor, 250 V, 20 J
RV2,RV5	400-00718	Varistor, 1 kV, 80 J
RV3,RV6	400-00717	Varistor, 275 V, 40 J
S1	431-00106	Switch, DPST, 4 Position
T1	410-00209	U-0256, Transformer
T2	410-00208	U-0255, Transformer
TB1	420-00081	Terminal Block, 16 POS

COMPONENT DESIGNATION	BECO NUMBER	DESCRIPTION
U1	400-00667	Voltage Regulator, Integrated Circuit, LH0070-OH
U2	560-00043	Quad Op Amp, Integrated Circuit, CA224, SMT
U3	560-00042	Quad Op Amp, Integrated Circuit, TLC274, SMT
U4	540-00097	Quad 2 AND Gate, CD4081B D/M, SMT
U5	560-00008	Voltage Regulator, LM317, 40V
VR1	400-00061	Diode, 36 V, IN5365A
VR3	400-00270	Diode, Zener, 15 V, CMZ592B, SMT
VR4	400-00275	Diode, Zener, 3.6 V, CMZ52278, SMT
REV. A		

Patent

The units described in this manual are covered by U.S. Patents, with other patents pending.

Buyer shall hold harmless and indemnify the Seller, its directors, officers, agents, and employees from any and all costs and expense, damage or loss, resulting from any alleged infringement of United States Letters Patent or rights accruing therefrom or trademarks, whether federal, state, or common law, arising from the Seller's compliance with Buyer's designs, specifications, or instructions.

Warranty

Seller hereby warrants that the goods which are the subject matter of this contract will be manufactured in a good workmanlike manner and all materials used herein will be new and reasonably suitable for the equipment. Seller warrants that if, during a period of five years from date of shipment of the equipment, the equipment rendered shall be found by the Buyer to be faulty or shall fail to perform in accordance with Seller's specifications of the product, Seller shall at his expense correct the same, provided, however, that Buyers shall ship the equipment prepaid to Seller's facility. The Seller's responsibility hereunder shall be limited to replacement value of the equipment furnished under this contract.

Seller makes no warranties expressed or implied other than those set out above. Seller specifically excludes the implied warranties of merchantability and fitness for a particular purpose. There are no warranties which extend beyond the description contained herein. In no event shall Seller be liable for consequential, exemplary, or punitive damages of whatever nature.

Any equipment returned for repair must be sent with transportation charges prepaid. The equipment must remain the property of the Buyer. The aforementioned warranties are void if the value of the unit is invoiced to the Seller at the time of return.

Indemnification

The Seller shall not be liable for any property damages whatsoever or for any loss or damage arising out of, connected with, or resulting from this contract, or from the performance or breach thereof, or from all services covered by or furnished under this contract.

In no event shall the Seller be liable for special, incidental, exemplary, or consequential damages, including but not limited to, loss of profits or revenue, loss of use of the equipment or any associated equipment, cost of capital, cost of purchased power, cost of substitute equipment, facilities or services, downtime costs, or claims or damages of customers or employees of the Buyer for such damages, regardless of whether said claim or damages is based on contract, warranty, tort including negligence, or otherwise.

Under no circumstances shall the Seller be liable for any personal injury whatsoever.

It is agreed that when the equipment furnished hereunder are to be used or performed in connection with any nuclear installation, facility, or activity, Seller shall have no liability for any nuclear damage, personal injury, property damage, or nuclear contamination to any property located at or near the site of the nuclear facility. Buyer agrees to indemnify and hold harmless the Seller against any and all liability associated therewith whatsoever whether based on contract, tort, or otherwise. Nuclear installation or facility means any nuclear reactor and includes the site on which any of the foregoing is located, all operations conducted on such site, and all premises used for such operations.

Notice:

Any illustrations and descriptions by Beckwith Electric Co., Inc. are for the sole purpose of identification.

The drawings and/or specifications enclosed herein are the proprietary property of Beckwith Electric Co., Inc., and are issued in strict confidence; therefore, shall not be used as a basis of reproduction of the apparatus described therein without written permission of Beckwith Electric Co., Inc.

No illustration or description contained herein shall be construed as an express warranty of affirmation, promise, description, or sample, and any and all such express warranties are specifically excluded nor shall such illustration or description imply a warranty that the product is merchantable or fit for a particular purpose. There shall be no warranties which extend beyond those contained in the Beckwith Electric Co., Inc. terms of sale.



BECKWITH ELECTRIC CO., INC.

6190 - 118th Avenue North • Largo, Florida 33773-3724 U.S.A.

PHONE (727) 544-2326 • FAX (727) 546-0121

E-MAIL marketing@beckwithelectric.com

WEB PAGE www.beckwithelectric.com