



INSTALLATION • OPERATION • MAINTENANCE INSTRUCTIONS

TYPE TRB ZENER TRIPPING UNIT

APPLICATION

The TRB Zener tripping unit is an auxiliary device energized by protective relays to trip circuit breakers in a double trip relaying scheme. It is suitable for cases where the total trip current of the two breakers is within the relay contact rating, usually 30 amperes. The TRB-2 unit can also be used for isolation of multiple trip paths to one breaker.

CONSTRUCTION & OPERATION

TRB Zener tripping units consist of 50-watt Zener diodes on brass plates contained within a short metal cage and mounted on a small molded base. The TRB-2 unit contains two diode circuits which are completely independent from each other. These circuits may have only one diode each or, in the case of 250 V d.c. ratings, may each have two diodes in series.

TRB-3 units contain three diodes, two of which have a common anode terminal and separate cathode terminals. The third diode is completely independent from the other two.

TRB-4 units contain four diodes in two completely independent circuits. Each circuit has two diodes which have a common anode terminal and separate cathode terminals.

The TRB Zener tripping unit is energized through contacts of protective relays as shown in Fig. 1. Relay contacts PR trips two breakers through diodes D1 and D2. However, relay contacts #1 and #2 can energize only their own related breakers #1 and #2 respectively because current flow to the adjacent breaker trip coil is blocked by diodes D1 and D2. Thus relays associated with each particular breaker are isolated from the other breaker, yet both breakers can be tripped, without additional time delay, by the operation of a common relay.

Transient voltages induced into the diode circuits in excess of their reverse blocking rating can be tolerated without damage to the diodes. This feature results from the zener characteristic which allows current to flow in the reverse direction and limits the voltage across the diode.

CHARACTERISTICS AND RATINGS

TYPE	RATING	DIODE	ONE SEC. RATING	MAXIMUM FORWARD VOLTS DROP	MAXIMUM REVERSE LEAKAGE CURRENT	ZENER REVERSE VOLTAGE IN VOLTS	MAXIMUM ZENER CURRENT
TRB-2	125VDC	1N2846	30 AMP	1.5	4 MA	200 ± 10%	75 MA
TRB-2	250VDC	1N2846	30 AMP	3.0	4 MA	400 ± 10%	75 MA
TRB-3	125VDC	1N2846	30 AMP	1.5	4 MA	200 ± 10%	75 MA
TRB-4	125VDC	1N2846	30 AMP	1.5	4 MA	200 ± 10%	75 MA

Internal Schematics are shown in Figs. 2, 3, and 4.

All possible contingencies which may arise during installation, operation, or maintenance, and all details and variations of this equipment do not purport to be covered by these instructions. If further information is desired by purchaser regarding his particular installation, operation or maintenance of his equipment, the local Westinghouse Electric Corporation representative should be contacted.

SUPERSEDES I.L. 41-842

*Denotes change from superseded issue.

EFFECTIVE DECEMBER 1971

TYPE TRB ZENER TRIPPING UNIT

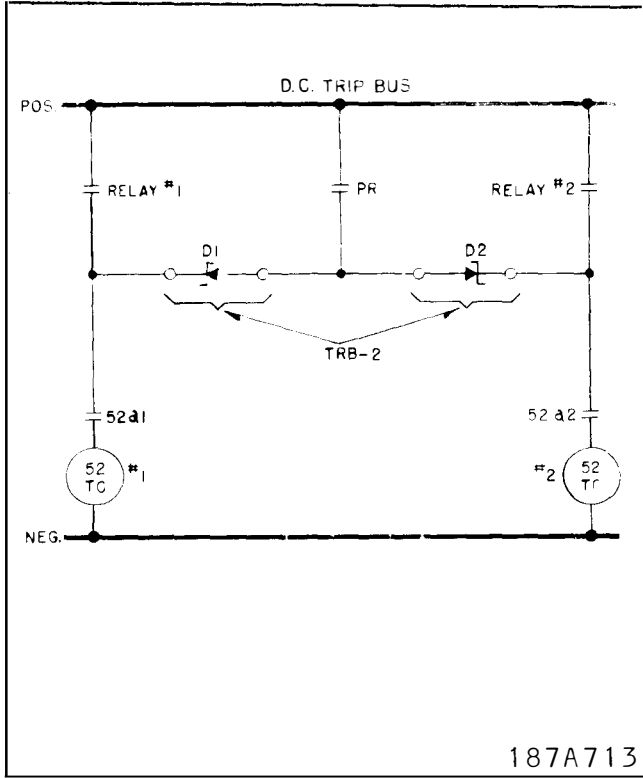

Fig. 1 Optional Schematic

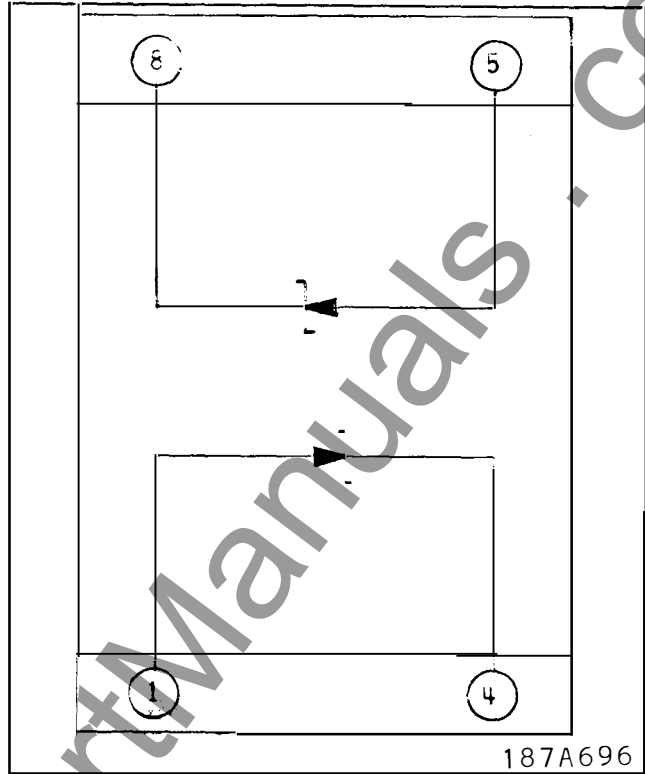

Fig. 2 Internal Schematic of Type TRB-2 Zener Tripping Unit.

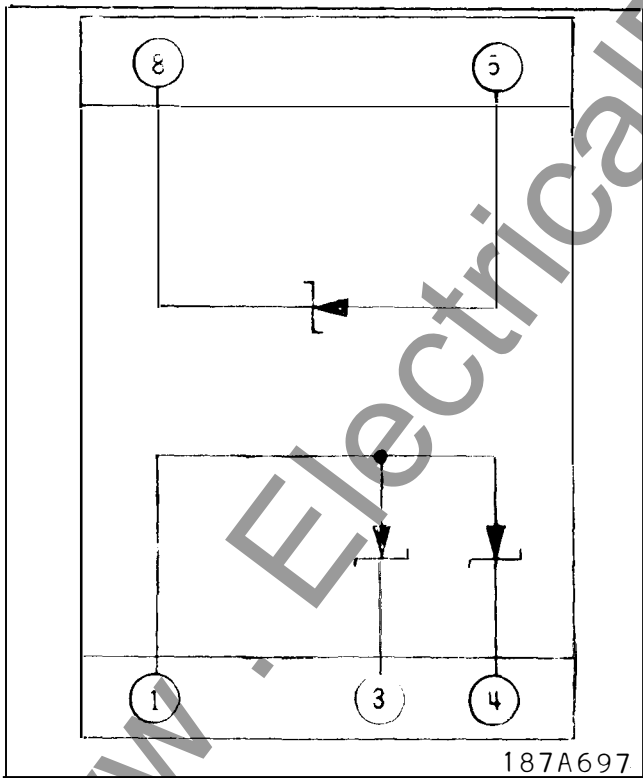

Fig. 3 Internal Schematic of Type TRB-3 Zener Tripping Unit.

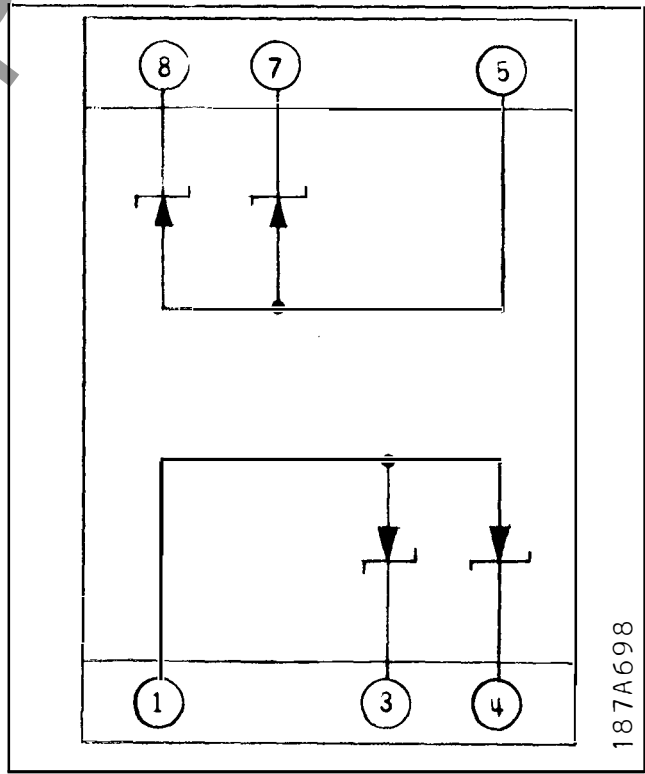

Fig. 4 Internal Schematic of Type TRB-4 Zener Tripping Unit.

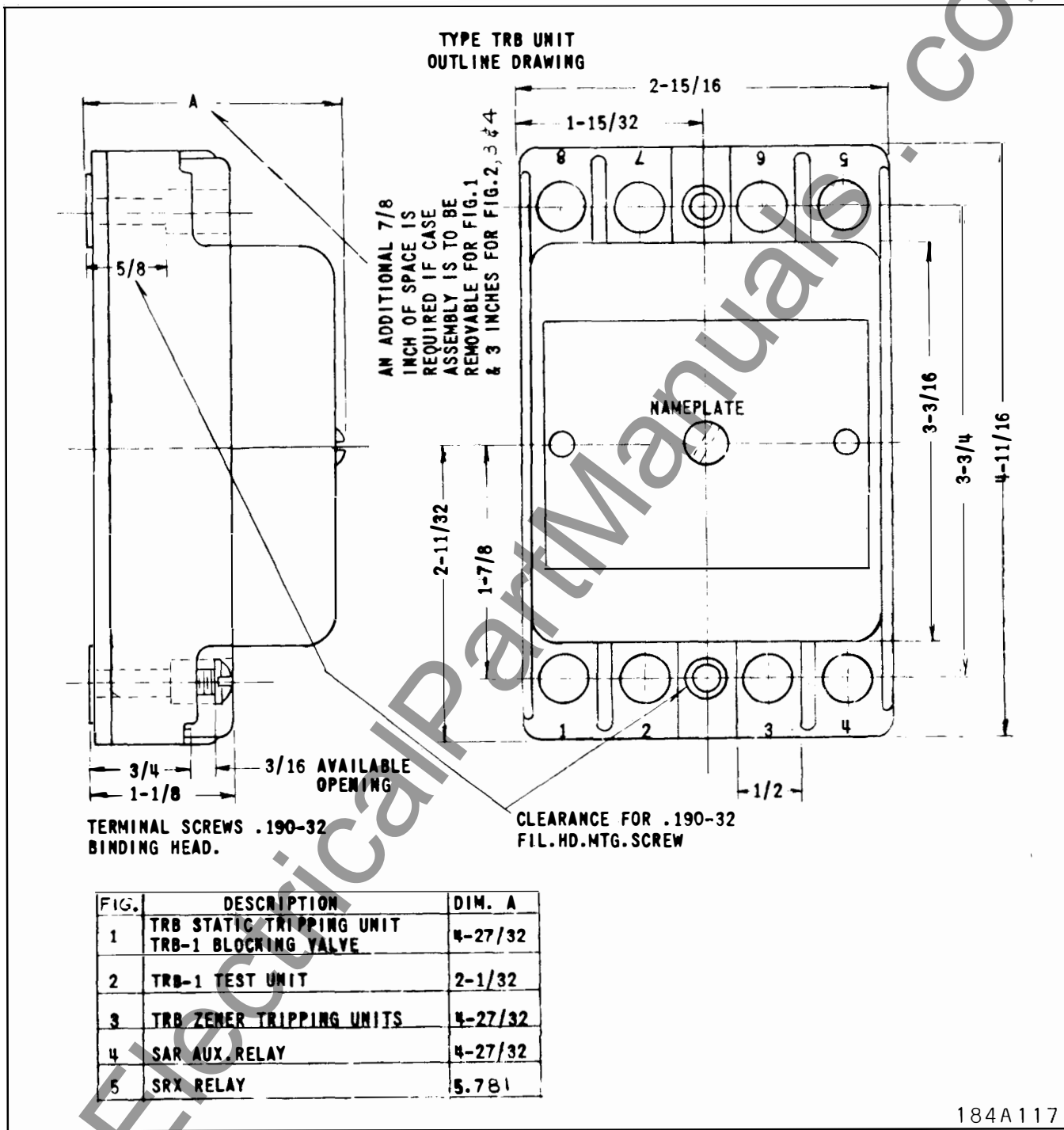

Fig. 5. Outline and Drilling Plan for Types TRB, TRB-1, TRB-2, TRB-3 and TRB-4 Zener Tripping Units.



WESTINGHOUSE ELECTRIC CORPORATION
RELAY-INSTRUMENT DIVISION

NEWARK, N. J.

Printed in U.S.A.



INSTALLATION • OPERATION • MAINTENANCE INSTRUCTIONS

TYPE TRB ZENER TRIPPING UNIT

APPLICATION

The TRB Zener tripping unit is an auxiliary device energized by protective relays to trip circuit breakers in a double trip relaying scheme. It is suitable for cases where the total trip current of the two breakers is within the relay contact rating, usually 30 amperes. The TRB-2 unit can also be used for isolation of multiple trip paths to one breaker.

CONSTRUCTION & OPERATION

TRB Zener tripping units consist of 50-watt Zener diodes on brass plates contained within a short metal cage and mounted on a small molded base. The TRB-2 unit contains two diode circuits which are completely independent from each other. These circuits may have only one diode each or, in the case of 250 V d.c. ratings, may each have two diodes in series.

TRB-3 units contain three diodes, two of which have a common anode terminal and separate cathode terminals. The third diode is completely independent from the other two.

TRB-4 units contain four diodes in two completely independent circuits. Each circuit has two diodes which have a common anode terminal and separate cathode terminals.

The TRB Zener tripping unit is energized through contacts of protective relays as shown in Fig. 1. Relay contacts PR trips two breakers through diodes D1 and D2. However, relay contacts #1 and #2 can energize only their own related breakers #1 and #2 respectively because current flow to the adjacent breaker trip coil is blocked by diodes D1 and D2. Thus relays associated with each particular breaker are isolated from the other breaker, yet both breakers can be tripped, without additional time delay, by the operation of a common relay.

Transient voltages induced into the diode circuits in excess of their reverse blocking rating can be tolerated without damage to the diodes. This feature results from the zener characteristic which allows current to flow in the reverse direction and limits the voltage across the diode.

CHARACTERISTICS AND RATINGS

TYPE	RATING	DIODE	ONE SEC. RATING	MAXIMUM FORWARD VOLTS DROP	MAXIMUM REVERSE LEAKAGE CURRENT	ZENER REVERSE VOLTAGE IN VOLTS	MAXIMUM ZENER CURRENT
TRB-2	125VDC	IN2846	30 AMPS	1.5	4 MA	200 ± 10%	75 MA
TRB-2	250VDC	IN2846	30 AMPS	3.0	4 MA	400 ± 10%	75 MA
TRB-3	125VDC	IN2846	30 AMPS	1.5	4 MA	200 ± 10%	75 MA
TRB-4	125VDC	IN2846	30 AMPS	1.5	4 MA	200 ± 10%	75 MA

Internal Schematics are shown in Figs. 2, 3, and 4.

All possible contingencies which may arise during installation, operation, or maintenance, and all details and variations of this equipment do not purport to be covered by these instructions. If further information is desired by purchaser regarding his particular installation, operation or maintenance of his equipment, the local Westinghouse Electric Corporation representative should be contacted.

SUPERSEDES I.L. 41-842

*Denotes change from superseded issue.

EFFECTIVE DECEMBER 1971

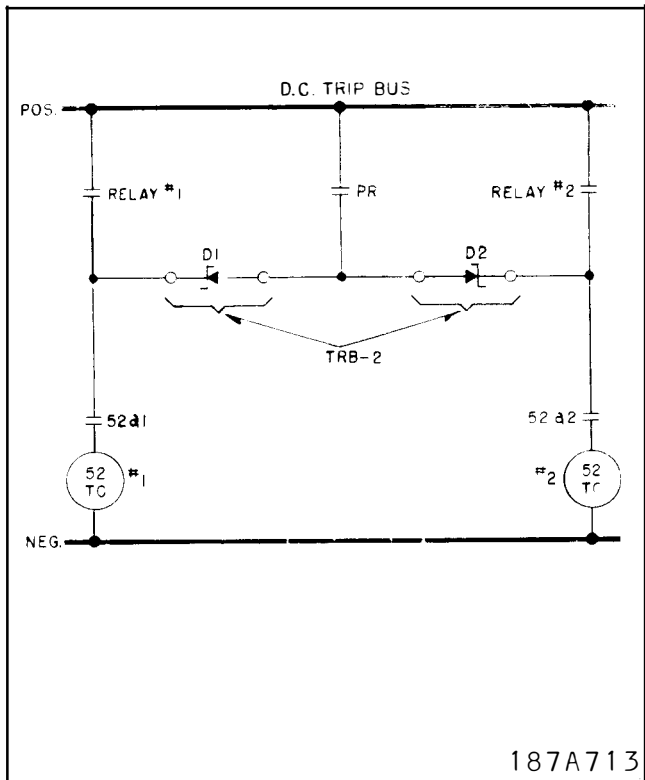

Fig. 1 Optional Schematic

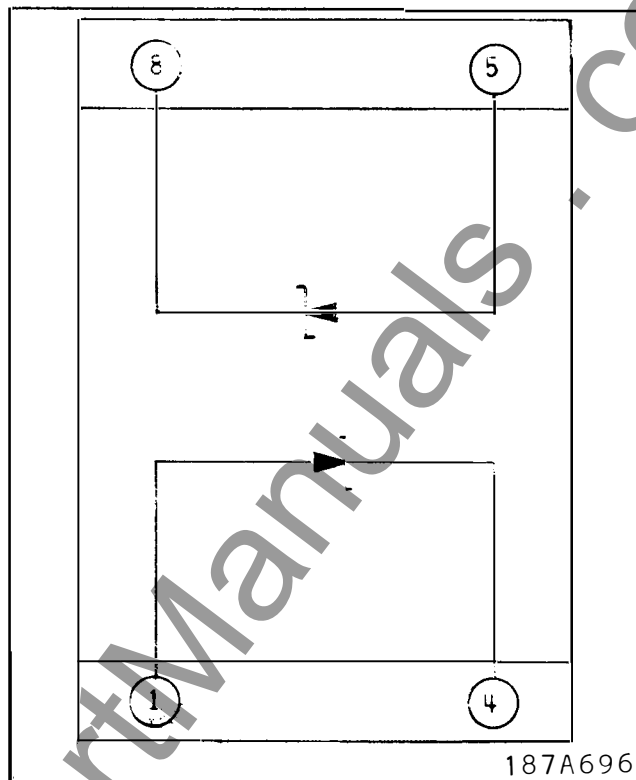

Fig. 2 Internal Schematic of Type TRB-2 Zener Tripping Unit.

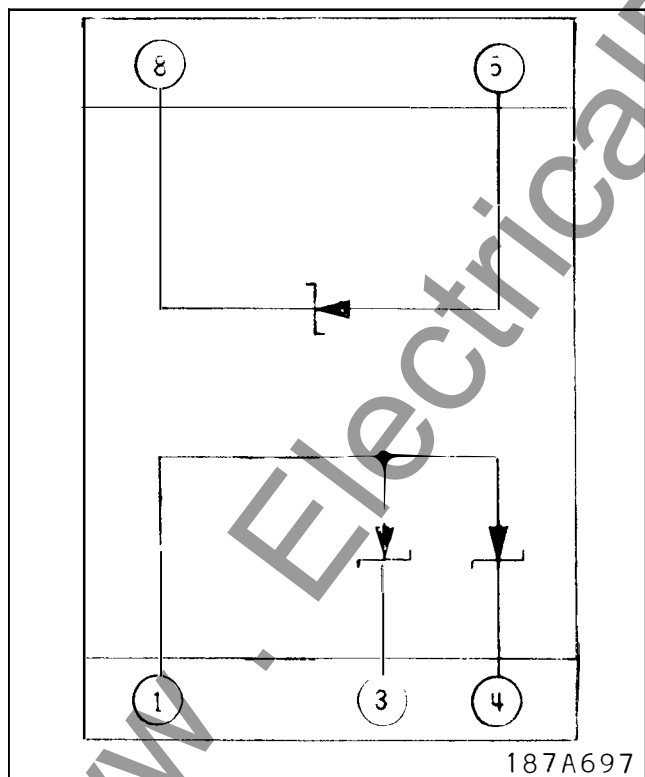

Fig. 3 Internal Schematic of Type TRB-3 Zener Tripping Unit.

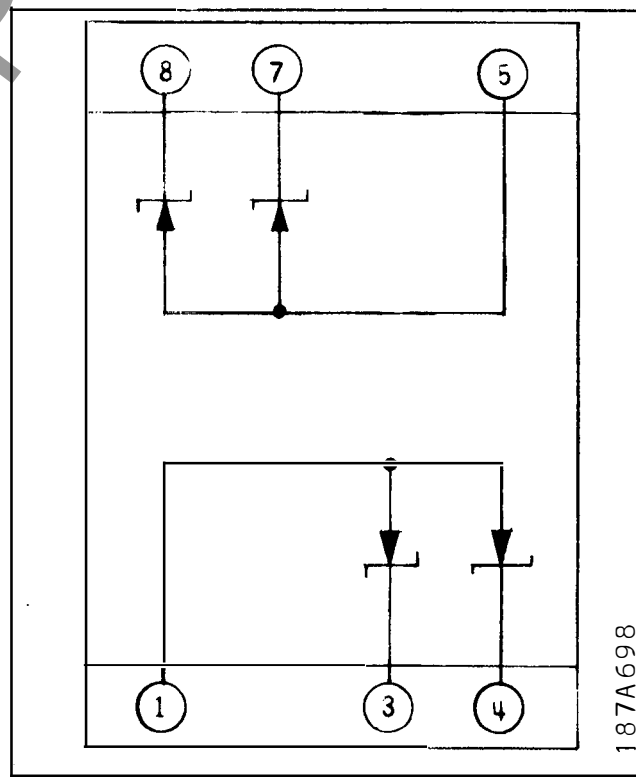

Fig. 4 Internal Schematic of Type TRB-4 Zener Tripping Unit.

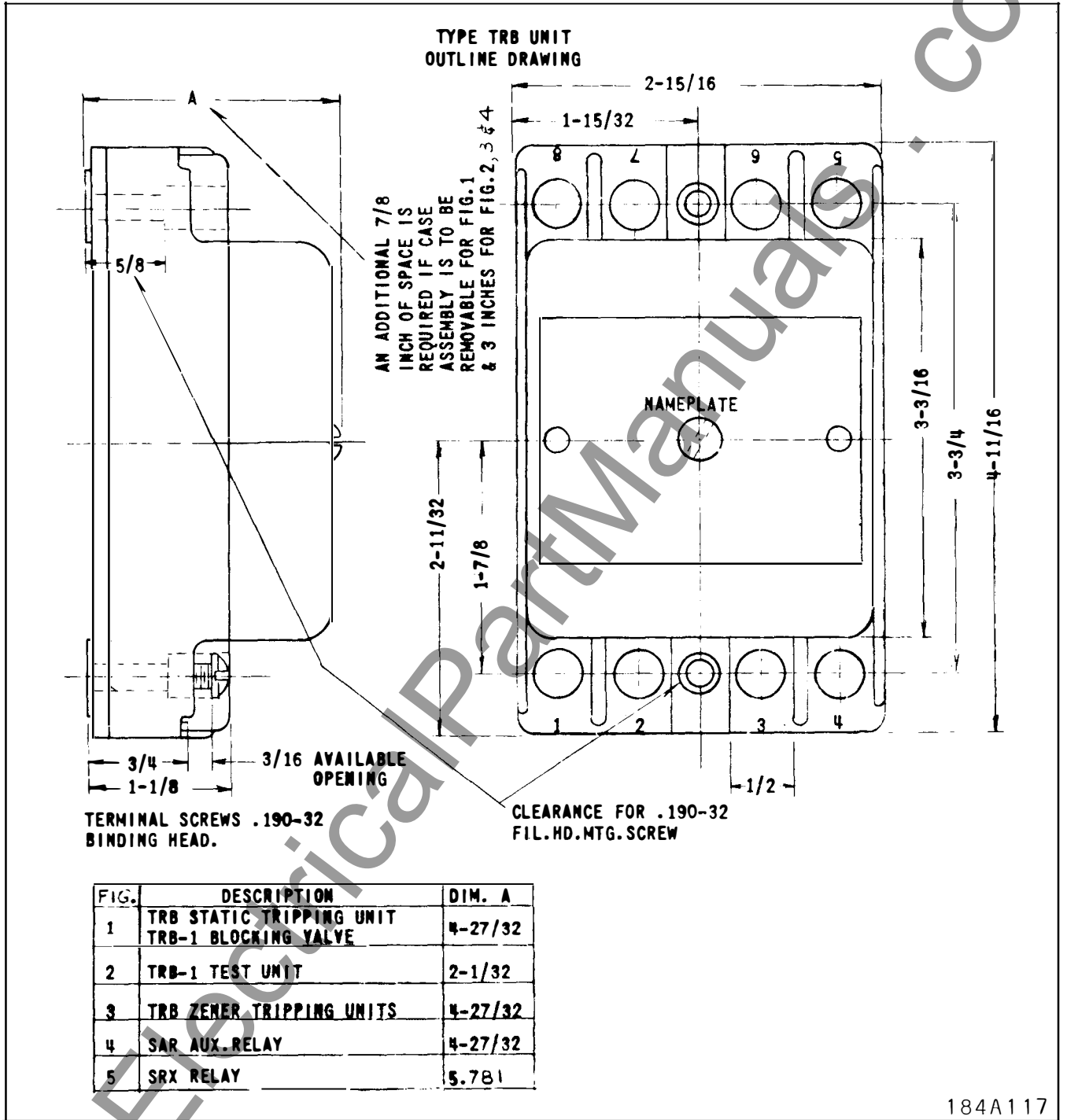

Fig. 5. Outline and Drilling Plan for Types TRB, TRB-1, TRB-2, TRB-3 and TRB-4 Zener Tripping Units.

184A117



WESTINGHOUSE ELECTRIC CORPORATION
RELAY-INSTRUMENT DIVISION

CORAL SPRINGS, FL.

Printed in U.S.A.