

AC-PRO

AC TRIP UNIT

MICRO-CONTROLLER BASED

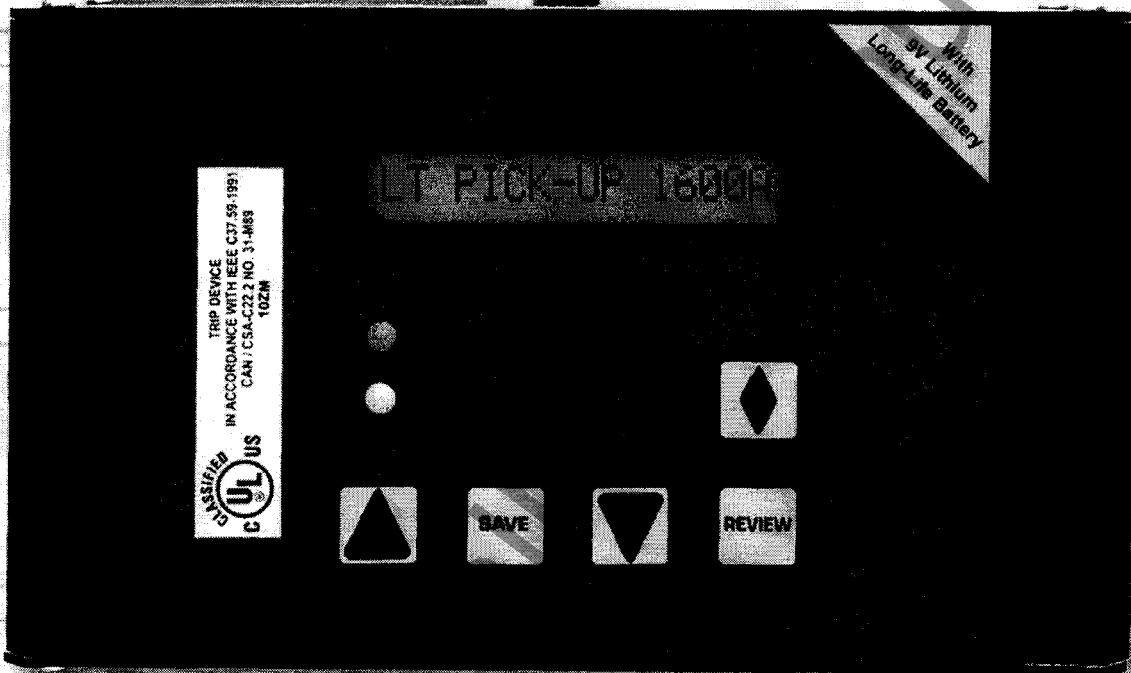

INSTRUCTION MANUAL

State of the art technology for low voltage circuit breaker retrofitting

URC Utility Relay Company

Chagrin Falls, OH 44023
Phone: 888.289.2864
www.utilityrelay.com

Manual Rev 1.1

1. INTRODUCTION.....	2	10.6	U/B TRIP TEST.....	17
		10.7	ERASE LAST TRIP DATA	17
2. UL/ULC CLASSIFICATION.....	2	11.	RATINGS	18
3. TRIP UNIT POWER	3	12.	WARRANTY.....	18
3.1	CURRENT TRANSFORMER (CT) POWER.....	3		
3.2	BATTERY POWER.....	3		
3.3	AUXILIARY POWER.....	4		
4. EXTERNAL CONNECTIONS	4	13.	TIME-CURRENT CURVES	19
4.1	BREAKER WIRING HARNESS.....	4	13.1	LT TRIP TIME
4.2	SECURITY KEY	4	13.2	ST TRIP TIME
4.3	REMOTE DISPLAY.....	5	13.3	GF TRIP TIME
			13.4	U/B TRIP TIME
5. FRONT VIEW	6	14.	ERROR MESSAGE SUMMARY.....	22
5.1	16 CHARACTER DISPLAY	7	14.1	ACTUATOR NOT CONNECTED.....
5.2	PICK-UP LED.....	7	14.2	MEMORY ERROR
5.3	SELF TEST LED.....	7		
5.4	DISPLAY CONTRAST	7	15. FIGURES	
5.5	UP	7	15.1	WIRING DIAGRAM.....
5.6	DOWN.....	7	15.2	OVERLOAD TCC
5.7	SAVE.....	7	15.3	U/B & GF TCC
5.8	REVIEW.....	7		
6. COMMISSIONING.....	8			
6.1	POWERING-UP THE TRIP UNIT	8		
6.2	SECURITY KEY DURING COMMISSIONING.....	8		
6.3	CT RATING.....	9		
6.4	LONG TIME (LT) PICK-UP SETTING.....	9		
6.5	LONG TIME (LT) DELAY SETTING.....	9		
6.6	SHORT TIME (ST) PICK-UP SETTING.....	10		
6.7	SHORT TIME (ST) DELAY SETTING.....	10		
6.8	SHORT TIME (ST) I ² T	10		
6.9	INSTANTANEOUS (I) PICK-UP SETTING.....	10		
6.10	GROUND FAULT (GF) PICK-UP SETTING.....	11		
6.11	GROUND FAULT (GF) DELAY SETTING	11		
6.12	GROUND FAULT (GF) I ² T.....	11		
6.13	PHASE UNBALANCE (U/B) PICK-UP	12		
6.14	PHASE UNBALANCE (U/B) DELAY	12		
6.15	EXIT PROCEDURE.....	12		
7. CHANGING SETTINGS	13			
8. TARGET RECALL OF LAST TRIP DATA.....	13			
9. NORMAL OPERATION.....	15			
10. TESTING.....	16			
10.1	COMMISSION THE TRIP UNIT	16		
10.2	LT TRIP TEST	16		
10.3	ST TRIP TEST.....	16		
10.4	I TRIP TEST.....	16		
10.5	GF TRIP TEST	16		

Firmware Revision: 4.00

1. Introduction

The AC-PRO is a state of the art, micro-controller based trip unit for use on three phase, 600 Volt class, AC circuit breakers. Models are available for use on 60 Hz, 50 Hz, 40 Hz, and 25 Hz systems.

The AC-PRO is a digital trip unit that uses a Motorola 8-bit micro-controller and a 16-character liquid crystal display (LCD).

The AC-PRO measures the true RMS current through each of the breaker's three poles. The trip unit also does a vector sum of the three phase currents (and neutral current if applicable) and determines the fundamental frequency component of any ground fault current.

The trip unit provides over-current, as well as short time and instantaneous fault protection. The trip unit also offers ground fault and phase unbalance (U/B) tripping functions as user selectable options.

The trip unit stores trip data in a non-volatile FRAM memory for later recall. The settings are stored in non-volatile EEPROM memory.

The trip unit does not require external power to operate. Power is derived from the current transformers (CTs). An internal battery provides power to review and change protection settings when CT power is unavailable.

All settings are made directly in **amps** or in **seconds**. A security system reduces the risk of unauthorized tampering with the trip unit settings.

2. UL/ULC Classification

AC-PRO is UL and ULC classified for use on the following low voltage AC power circuit breakers:

Westinghouse DB-50
General Electric AK-50
General Electric AK-75

UL and ULC classification is in accordance with UL1066, CSA C22.2, IEEE C37.59-1991 as well as appropriate sections of ANSI C37.17-1979 and C37.50-1989.

AC-PRO was tested by an independent laboratory and found in compliance with the following tests:

RF Susceptibility
Surge Withstand
15KV Electro-Static Discharge
Accuracy @ -20°C & +65°C

3. Trip Unit Power

The AC-PRO can be powered in 3 different ways: CTs, battery, or auxiliary power pack.

3.1 Current Transformer (CT) Power

The AC-PRO derives both signal and power from the breaker phase CTs. The trip unit will power-up with less than 10% of the rated CT tap current through a single CT (20% for the 1/2 Amp version). This current is below the lowest pick-up setting.

3.2 Battery Power

A 9-volt, 1200 mAh, long life, lithium/manganese dioxide battery is used in the trip unit. This battery has less than 2 grams of lithium. There are no restrictions on transport and no special methods of disposal required with this battery.

The battery is designed to provide two functions:

- 1) Allow the user to commission (program) the trip unit without using the auxiliary power pack.
- 2) Allow the user to recall the last trip data even if the breaker is open and without using the auxiliary power pack.

Press the "REVIEW" push button to turn on the trip unit under Battery power.

When on battery power, the trip unit will automatically turn off after 30 seconds to conserve battery energy.

**** NOTE ****

The battery is NOT involved in the protective functions of the trip unit. The trip unit will provide protection even if the battery is removed.

The battery is NOT required for the trip unit to maintain any of its memory including the user programmed pick-up and delay settings or the last trip data.

Lithium battery ratings:

- ?? Rated shelf life of ten-years
 - ?? 1200 mAh Capacity
- (Allows the review of last trip data and settings over 1500 times on battery power only)

To gain access to the battery, remove the four screws securing the top cover plate on the trip unit.

**** IMPORTANT ****

For best performance, replace with the following 9-volt lithium battery.

Ultralife Model U9VL-FP

An alkaline type 9-volt battery may also be used with much shorter life.

The breaker must be removed from service before removing the top cover on the trip unit.

3.3 Auxiliary Power

Auxiliary power is optional. It can be used to change or review the trip unit settings without using the internal battery.

Plug the 24-VAC auxiliary power pack into the auxiliary power jack on the top of the trip unit.

The power pack is available from Utility Relay Company as part number T-390.

4. External Connections

The external connections are made to the top of the AC-PRO trip unit (or the left or right side for the vertical versions).

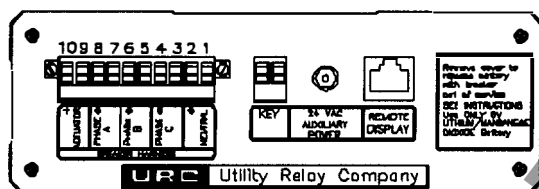

Figure 4.1 AC-PRO Top View

4.1 Breaker Wiring Harness

The breaker wiring harness connects the trip unit to the CTs and actuator. The wiring harness plugs into the 10-pin connector on the top of the trip unit and is retained with two screws.

Terminal	Function	Color Code
1	Neutral CT	White
2	Neutral CT	Green
3	Phase C	White
4	Phase C	Brown
5	Phase B	White
6	Phase B	Yellow
7	Phase A	White
8	Phase A	Blue
9	Actuator (-)	Black
10	Actuator (+)	Red

Table 4.1 Breaker Wiring Harness Pin-Out

A neutral CT wiring harness is provided as part of the neutral CT installation kit and is only required with ground fault on a 4-wire system. The ground fault function on a 3-wire system does not require a neutral CT.

4.2 Security Key

The AC-PRO trip unit contains a security feature that only allows someone familiar with the operation of the trip unit to commission the trip unit or make changes to the settings. A security key is required to change any of the settings.

The "Key" is simply a short jumper wire that is connected between the two terminals marked "KEY" on the top of the trip unit.

Refer to Figure 4.1 AC-PRO Top View.

To turn the security **Key "ON"**:
Jumper the two terminals labeled "KEY" on the top of the trip unit.

To turn the security **Key "OFF"**:
Remove the jumper wire.

The key allows the user to commission the trip unit or to change the settings on a trip unit by performing the steps as outlined in sections 6.0 and 7.0.

4.3 Remote Display

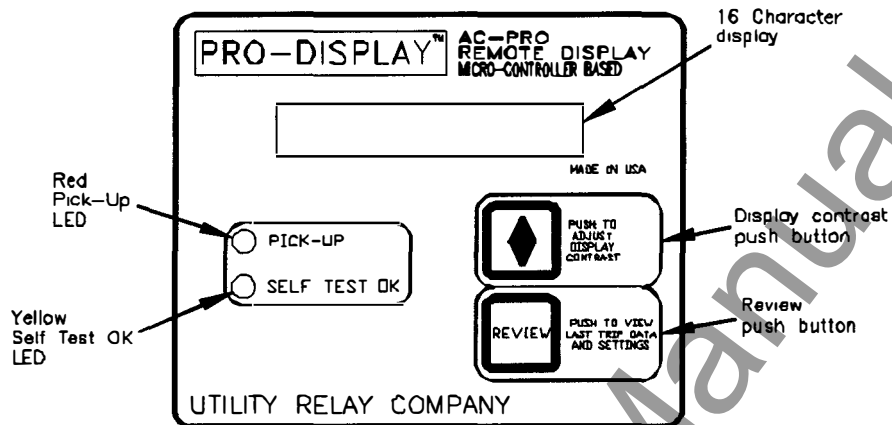

Figure 4.2 PRO-DISPLAY Front View

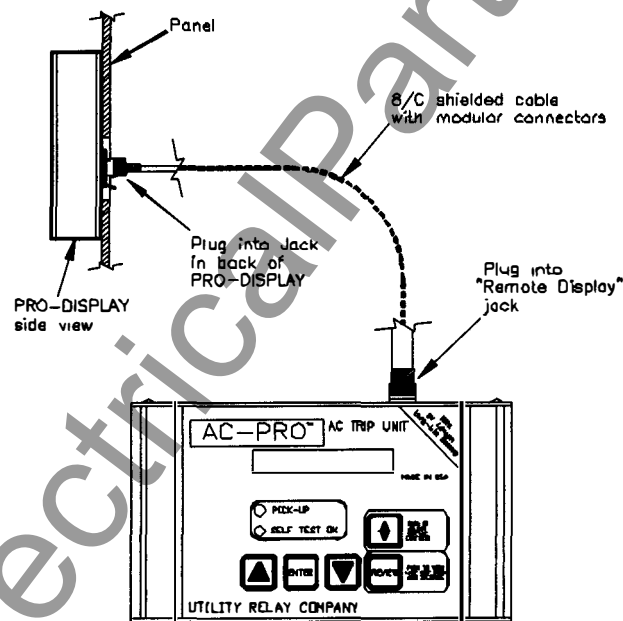

Figure 4.3 PRO-DISPLAY Connection

A panel mount remote display is available as an option for the AC-PRO. It is mounted on the front of the cubicle door. It provides the capability of viewing the breaker currents and reviewing the settings and the last trip data **without opening the breaker cubicle door.**

For security reasons, it is not possible to change any settings from the remote display.

A shielded cable with modular type connectors is provided to connect the trip unit to the remote display. See the Remote Display manual for more details.

5. Front View

The front view of the horizontal version of the AC-PRO trip unit is shown in Figure 5.1. The front view of the vertical version of the AC-PRO is shown in Figure 5.2.

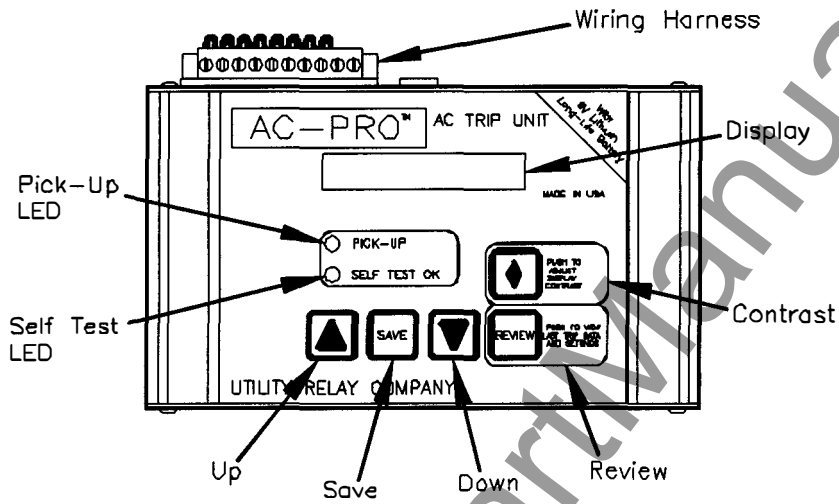

Figure 5.1 AC-PRO Horizontal Front View

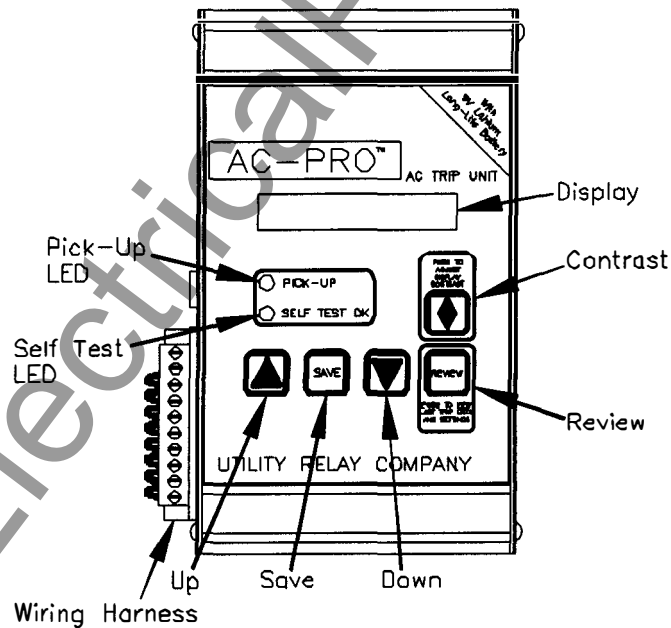

Figure 5.2 AC-PRO Vertical Front View

5.1 16 Character Display

A 16-character dot matrix liquid crystal display (LCD) provides information to the user.

The LCD is used for the following purposes:

- 1) Entering the CT rating and making the pick-up and time delay settings with prompts from the display.
- 2) Displaying, on demand, the CT rating and the various pick-up and delay settings.
- 3) Displaying, on demand, the reason for the last trip and the currents at the time of trip.
- 4) Continuously displaying the actual 3-phase AC currents on the circuit.

5.2 Pick-Up LED

The Pick-Up LED is normally off. It will turn on whenever the breaker current is above the LT Pick-up setting.

5.3 Self Test LED

The Self Test LED is normally on. It will turn off under the following conditions:

- 1) The actuator is not connected. The LCD will also display an error message.
- 2) There is a checksum error in the micro-controller. The LCD will also display an error message.

5.4 Display Contrast

The contrast level of the LCD can be adjusted by pressing this push button.

When the contrast push button is pressed and held, the display will begin to get either darker or lighter. To change direction, release the push button for more than 1 second, then press and hold the push button until the desired contrast is achieved.

5.5 Up

Use this push button to increase the setting values during commissioning. When the push button is held longer than 1 second, the settings are increased in fast mode.

When the maximum setting value is reached, the increase push button will have no further effect on the setting value.

5.6 Down

Use this push button to decrease the setting values during commissioning. When the push button is held longer than 1 second, the settings are decreased in fast mode.

When the minimum setting value is reached, the decrease push button will have no further effect on the setting value.

5.7 Save

Use this push button to step through the settings when in the commissioning mode.

Holding this push button has no effect.

5.8 Review

Use this push button to step through the settings in the settings review mode. Also use this push button to turn the trip unit on using battery power.

Hold this push button down to review trip counts during the settings review.

www.ElectricalPartManuals.com

6. Commissioning

Before the AC-PRO trip unit is put into service, it must first be commissioned so it will function. This requires the user to enter all of the pick-up and delay settings into the unit.

The commissioning process normally takes less than a few minutes to complete.

**** IMPORTANT ****

The trip unit will NOT FUNCTION as it is shipped from the factory. The user must first COMMISSION the unit as outlined in this Section to make it functional.

After the AC-PRO is installed on the breaker, it must be commissioned as follows:

- 1) Connect the security key (see Section 4.2)
- 2) Push the "REVIEW" push button to power-up the trip unit. The trip unit will alternately display the following:

ENTER DATA

SERIAL # XXXXXXXX

Press the "SAVE" push button. The following will be displayed:

PROD: AC01V3.XX

Press the "SAVE" push button to begin the commissioning process.

- 3) Enter the appropriate CT tap, pick-up and delay settings using the "UP", "DOWN" and "SAVE" push buttons.
- 4) Remove the security key (see Section 4.2).

Sections 6.1 through 6.15 go over the commissioning process in greater detail.

NOTE: An additional security feature is provided to avoid accidentally changing the CT tap setting. See Section 6.3.

6.1 Powering-Up The Trip Unit

In normal service, the AC-PRO trip unit is powered directly from the breaker mounted CTs.

For commissioning, the AC-PRO trip unit can be powered-up in either of the following two ways.

1) Internal Battery

Press the "REVIEW" button to power-up the trip unit using the internal battery.

The trip unit is designed to shut off automatically if none of the 4 lower push buttons on the face of the unit are pressed for 30 seconds. It, therefore, is best to have all the desired settings readily available before commissioning the unit when using the battery.

If the unit shuts down before the commissioning process is completed, the process must be started again from the beginning.

2) External Power

Apply 24 VAC to the "auxiliary power" jack located on the top of the trip unit using the Utility Relay auxiliary power pack, part T-390.

By applying external power, the unit will stay energized as long as necessary to complete the commissioning process.

6.2 Security Key During Commissioning

The following will be displayed if the security key is not already connected:

SECURITY KEY OFF

Connect the security key to continue the commissioning process. See Section 4.2.

www.ElectricalPartManuals.com

6.3 CT Rating

After the security key is connected, the following will be displayed:

CT RATING	XXXXA
-----------	-------

Where "XXXX" represents the CT rating in amps. The CT rating can range from 50 amps to 5,000 amps in 25 amp steps and 5250 amps to 6000 amps in 250 amp steps.

The CT rating entered into the trip unit **must** correspond to the actual rating of the phase and neutral CT tap that the trip unit is connected to. A security feature is provided so the CT rating will not be accidentally changed later.

The CT security feature must be used to enter the initial CT rating or to change the CT rating.

To Activate the CT Security Feature

- ??In the commissioning mode
- ??When the CT rating is displayed
- ??Simultaneously push and release both the "SAVE" and "REVIEW" push buttons
- ??This allows the CT rating to be changed

With the security feature activated, press and hold the "UP" or "DOWN" push button as required until the correct CT rating is displayed.

Press the "SAVE" push button to continue.

6.4 Long Time (LT) Pick-Up Setting

The following will be displayed:

LT PICK-UP	XXXXA
------------	-------

Where "XXXX" represents the LT Pick-Up setting in amps. The LT Pick-Up setting ranges from 20% to 100% of the CT rating. This setting is adjustable in 5 amp steps (50 amp steps for 5250 amp to 6000 amp CTs).

Press and hold the "UP" or "DOWN" push button as required until the correct LT Pick-Up setting is displayed.

Press the "SAVE" push button to continue.

6.5 Long Time (LT) Delay Setting

The following will be displayed:

LT DELAY	XX.XS
----------	-------

Where "XX.X" represents the LT Delay band. The LT Delay band is labeled by the number of seconds to trip at **6 times** the LT Pick-Up setting.

The LT Delay setting ranges from 2.0 to 30 seconds in steps of 0.5 seconds. This provides 57 LT Delay bands.

Please note that the LT trip time is not a constant value, but is a function of breaker current. For low currents the trip time is longer, and for higher currents the trip time is shorter. The trip time is only equal to the LT Delay setting when a current 6 times the LT Pick-Up setting is applied. See the time-current curves in Section 15.

Press and hold the "UP" or "DOWN" push button as required until the correct LT Delay setting is displayed.

Press the "SAVE" push button to continue.

www.ElectricalPartManuals.com

6.6 Short Time (ST) Pick-Up Setting

The following will be displayed:

ST PICK-UP OFF

If the ST function is **not** desired, press the "SAVE" push button and go to Step 6.9.

If the ST function **is** desired, press the "UP" push button and the following will be displayed:

ST PICK-UP XXXXA

Where "XXXX" represents the ST Pick-Up in amps.

The ST Pick-Up setting ranges from 150% to 1200% of the LT Pick-Up setting in 100 amp steps (1000 amp steps for 5250 to 6000 amp CTs). Press and hold the "UP" or "DOWN" push button as required until the correct ST Pick-Up setting is displayed.

Press the "SAVE" push button to continue.

6.7 Short Time (ST) Delay Setting

If the ST function is not off, then the following will be displayed:

ST DELAY .XXS

Where ".XX" represents the ST Delay.

The ST Delay settings are .07, .10, .15, .20, .30 and .40 seconds.

Press and hold the "UP" or "DOWN" push button as required until the correct ST Delay setting is displayed.

Press the "SAVE" push button to continue.

6.8 Short Time (ST) I²T

The I²T function adds a ramp to the ST delay if required for coordination purposes as shown in the Overload TCC in Figure 15.2.

If the ST function is not off, then the following will be displayed:

ST I²T XXX

Where "XXX" represents ON or OFF.

If the ST I²T ramp **is** desired, press the "UP" push button. If the ST I²T ramp **is not** desired, press the "DOWN" push button.

Press the "SAVE" push button to continue.

6.9 Instantaneous (I) Pick-Up Setting

The following will be displayed:

I PICK-UP XXXXXA

Where "XXXXX" represents the I Pick-Up in amps.

The I Pick-Up setting ranges from 150% to 1200% of the LT Pick-Up setting in 100 amp steps (1000 amp steps for 5250 to 6000 amp CTs).

Press and hold the "UP" or "DOWN" push button as required until the correct I Pick-Up setting is displayed.

If the I function is **not** desired and the ST function is **not** off, press the "DOWN" push button until the following is displayed:

I PICK-UP OFF

**** NOTE ****

The trip unit does not allow setting both the ST and the I functions off at the same time.

Press the "SAVE" push button to continue.

www.ElectricalPartManuals.com

6.10 Ground Fault (GF) Pick-Up Setting

If the GF function is **not** desired, then press the "DOWN" push button until the following is displayed:

GF PICK-UP	OFF
------------	-----

If the GF function **is** desired, press the "UP" push button and the following will be displayed:

GF PICK-UP	XXXXA
------------	-------

Where "XXXX" represents the GF Pick-Up setting in amps.

The minimum GF Pick-Up setting is 20% of the CT rating with 10 amp steps. The maximum value is 200% of the CT rating or 1200 amps, whatever is lower.

Press and hold the "UP" or "DOWN" push button as required until the correct GF Pick-Up setting is displayed.

Press the "SAVE" push button to continue.

6.11 Ground Fault (GF) Delay Setting

If the GF function is not off, then the following will be displayed:

GF DELAY	.XXS
----------	------

Where ".XX" represents the GF Delay.

The GF Delay settings are .10, .20, .30, .40 and .50 seconds.

Press and hold the "UP" or "DOWN" push button as required until the correct GF Delay setting is displayed.

Press the "SAVE" push button to continue.

6.12 Ground Fault (GF) I²T

The I²T function adds a ramp to the GF delay if required for coordination purposes as shown in the Ground Fault TCC in Figure 15.3.

If the GF function is not off, then the following will be displayed:

GF I ² T	XXX
---------------------	-----

Where "XXX" represents ON or OFF.

If the GF I²T ramp **is** desired, press the "UP" push button. If the GF I²T ramp **is not** desired, press the "DOWN" push button.

Press the "SAVE" push button to continue.

****** NOTE ******

On a 4-wire system, a neutral CT must be installed to avoid nuisance GF trips.

www.ElectricalPartManuals.com

6.13 Phase Unbalance (U/B) Pick-Up

The following will be displayed:

U/B PICK-UP OFF

If the U/B function is **not** desired, then press the "SAVE" push button and go to Step 6.15.

If the U/B function **is** desired, press the "UP" push button and the following will be displayed:

UB PICK-UP XX%

Where "XX" represents the U/B Pick-Up setting in percentage. The minimum and maximum UB Pick-Up setting is 20% and 50% in steps of 5 percentage points.

Press and hold the "UP" or "DOWN" push button as required until the correct U/B Pick-Up setting is displayed.

Press the "SAVE" push button to continue.

**** NOTE ****
The U/B function should not be confused with the GF function.
The U/B function is a motor protection function and should **ONLY** be used on breakers feeding a large 3-phase motor where unbalanced currents are not normal.

6.14 Phase Unbalance (U/B) Delay

If the U/B function is not off, then the following will be displayed:

UB DELAY XXS

Where "XX" represents the U/B Delay. The U/B Delay setting ranges from 1 to 60 seconds in steps of 1 second.

Press and hold the "UP" or "DOWN" push button as required until the correct U/B Delay setting is displayed.

Press the "SAVE" push button to continue.

6.15 Exit Procedure

The following will be displayed:

SAVE IF DONE

REVIEW TO REVIEW

If it is desired to review the setting, push the "REVIEW" push button. Make any changes necessary using the "UP" or "DOWN" push buttons. As before, use the "SAVE" push button to move to each new setting.

If the settings are as desired, push the "SAVE" push button.

The following will be displayed:

REMOVE KEY TO

COMMISSION UNIT

Remove the "key" (See section 4.2). The settings will be saved in the non-volatile EEPROM memory.

If the commissioning process was performed using the internal battery, the unit will turn itself off.

If external power was used to power the trip unit during the commissioning process, the following will be displayed:

LOW CURRENT

The commissioning process is complete.

www.ElectricalPartManuals.com

7. Changing Settings

****** IMPORTANT ******
 While it is possible to make changes to the settings with the breaker in service, it is strongly recommended that THE BREAKER BE REMOVED FROM SERVICE while making these changes since the trip unit will not provide protection during part of this process.

After the trip unit is commissioned, settings can easily be changed in the following manner.

Connect the security key. See Section 4.2.

Power up the trip unit by pressing "REVIEW" or by applying external power as described in Section 6.1.

Press the "REVIEW" push button. The following will be displayed:

ENTER DATA
 SERIAL # XXXXXXXX

Press the "SAVE" push button.

Make any necessary changes using the "UP" or "DOWN" push buttons. Use the "SAVE" push button to move to each new setting.

****** IMPORTANT ******
 The CT rating entered in the trip unit must match the rating of the CT the trip unit is connected to.
 A security feature protects against accidentally changing the CT rating. See Section 6.3.

After going through all the settings, the following will be displayed.

SAVE IF DONE
 REVIEW TO REVIEW

If it is desired to review the setting, push the "REVIEW" push button. Make any changes necessary using the "UP" or "DOWN" push buttons. As before, use the "SAVE" push button to move to each new setting.

If the settings are as desired, push the "SAVE" push button. The following will be displayed:

REMOVE KEY TO
 COMMISSION UNIT

Remove the security key (See Section 4.2). The settings will be saved in the non-volatile EEPROM memory.

The Settings have been changed.

Remember, if the trip unit loses power during this process, the old settings will be retained and the process must be repeated.

8. Target Recall of Last Trip Data

The AC-PRO has an especially useful target recall and trip counter system.

After a breaker trip, the trip unit will be able to display the type of trip (i.e. LT, ST, I, GF, or U/B as applicable) and the currents at the time of trip. This information is saved in the non-volatile FLASH memory and is available immediately after a trip or anytime thereafter.

****** NOTE ******
 Only the data from the last trip is saved. The second time the breaker trips, the new trip data is written over the first trip data. The trip counter is also updated at this time.

a) Push the "Review" push button to recall the Last Trip Data and settings. The following will be displayed if there was **no** last trip:

NO LAST TRIP

www.ElectricalPartManuals.com

If there was a last trip, the following messages will alternately display showing the cause of the trip and the currents at the time of trip. The messages alternate at a 1.0 second interval rate:

LAST TRIP XX

PHASE A XXXXXA

PHASE B XXXXXA

PHASE C XXXXXA

GF XXXXXA

If GF current is greater than 2 times the CT Rating, the following will be displayed for GF:

GF>2XCT RATING

Only those phase currents greater than 10% of the CT Rating will be displayed.

U/B YY%

The U/B percentage will only be displayed if greater than 4%.

The text "XX" is the type of tripping event (i.e. LT, ST, I, GF, or U/B as applicable) and "XXXXX" is the magnitude of the current at the time of trip for each phase. The text "YY" is the percentage of unbalance at trip.

- b) Press the "REVIEW" push button again to view the following message:

HOLD <REVIEW> TO

VIEW TRIP COUNTS

- c) If the "REVIEW" key is pushed again and held down for longer than 2 seconds, each type of trip is displayed along with the number of times that trip has occurred. If the "REVIEW" is pressed, but not held for 2 seconds, the trip count is skipped and the settings are displayed.

INST TRIPS: XX

LT TRIPS: XX

ST TRIPS: XX

GF TRIPS: XX

U/B TRIPS: XX

The text "XX" is the number of trips since last commissioned or reset.

- d) By pressing the "REVIEW" push button the present settings programmed in the trip unit can be stepped through in sequence.

**** NOTE ****

Pushing the "SAVE", "UP" or "DOWN" push buttons during "target recall" has no effect because the key is not installed.

When pushing "REVIEW" after the last setting, the trip unit will turn it self off. If the "REVIEW" push button is not pressed for about 30 seconds, the trip unit will also turn off.

www.ElectricalPartManuals.com

9. Normal Operation

Breaker Current Less than about 8% of CT Rating:

With all phase currents less than about 8%, the trip unit is not receiving enough energy from the CTs to operate and the display will be blank.

Breaker Current Less than 12.5% of CT Rating:

When the currents are greater than 8% but less than 12.5% of the CT rating, the display will show the following:

LOW CURRENT

Breaker Current Greater than 12.5% of CT Rating:

If the breaker current is greater than 12.5% of the CT rating but less than the LT pick-up value, the following will be alternately displayed on the LCD at 1-second intervals:

PHASE A	XXXXA
PHASE B	XXXXA
PHASE C	XXXXA
GF	XXXXA

Where "XXXX" is the current in amps for that phase or ground fault current.

Only those currents above 12.5% will be displayed. The GF current will only be displayed if the GF function is on.

Breaker Current Greater than the LT pick-up:

When the trip unit detects a phase overload situation, the "PICK-UP" LED on the front of the trip unit will go on, and the following will alternately be displayed on the LCD at 1-second intervals:

OVERLOAD	
PHASE A	XXXXA
PHASE B	XXXXA
PHASE C	XXXXA
GF	XXXXA

Where "XXXX" is the current in amps for that phase or ground fault current.

Only those currents above 12.5% will be displayed. The GF current will only be displayed if the GF function is on.

www.ElectricalPartManuals.com

10. Testing

A "primary injection" test is recommended as the final test of the AC-PRO retrofit.

It is not necessary to turn off the Unbalance (U/B) function when doing a single-phase primary injection test.

If used, GF must be temporarily turned OFF when testing the other trip functions.

10.1 Commission the Trip Unit

Before proceeding with the normal primary injection tests, the trip unit must be commissioned to make it functional. See Section 6.0 for the commissioning procedure.

It is best to use the final pick-up and time delay settings if they are known. If not, use typical settings for the primary injection test.

Make sure GF is temporarily set to "OFF". U/B can be left "ON".

10.2 LT Trip Test

Make sure GF is temporarily set to "OFF". The U/B function can be left "ON".

To test the LT Pick-Up, increase the current until the "Pick-Up" LED illuminates.

The injected current should correspond to the programmed LT Pick-Up setting. Verify that the correct phase is indicated on the LCD display.

To test the LT trip time, first calculate the trip time based on the value of the test current that will be applied. Use the formula in Section 13.1.

****** NOTE ******

A simple shortcut is to note that the trip time (center of the curve) at 3 times the LT pick-up current is 4 times the LT Delay setting.

For example:

If LT Pick-Up is 1600A and Delay is 10.0S, then the trip time at 4800A (3 times 1600A) is 40 sec. (4 times 10 sec).

10.3 ST Trip Test

Make sure GF is temporarily set to "OFF". The U/B function can be left "ON".

To test the ST Pick-Up, temporarily set ST I²T to OFF and apply a short pulse of current that is 10% or 20% less than the ST Pick-Up setting. Continue applying short pulses of current while increasing the current for each pulse until a ST trip occurs. The first current where a ST trip occurred is the ST Pick-Up.

To test the ST Delay, turn ST I²T on again (if applicable) and apply a current that is at least 10% greater than the ST Pick-Up current.

The trip time should fall within the time band shown on the Time-Current curves.

10.4 I Trip Test

Make sure GF is temporarily set to "OFF". The U/B function can be left "ON".

Test the Instantaneous Pick-Up and trip time in the same manner as ST.

10.5 GF Trip Test

With GF Pick-Up and Delay set to the required values, testing any one of the three poles will provide a GF trip.

Test the GF Pick-Up and trip time in the same manner as ST.

www.ElectricalPartManuals.com

10.6 U/B Trip Test

The U/B trip function is not easy to test with a single phase, high current test set.

Figure 10.1 illustrates a method to test the U/B trip function. It requires using cable or bus to jumper the breaker poles as shown. This generates an unbalanced current of 50% or slightly more depending on how equally the current is split between the two poles.

It is only necessary to inject a current equal to 20% or 30% of the CT rating for this test. It is only possible to test the U/B trip time and not the U/B Pick-Up with this method.

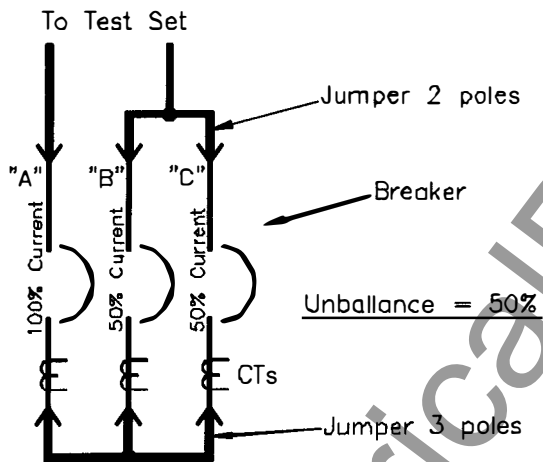

Figure 10.1 U/B Test

10.7 Erase Last Trip Data

After completing the primary injection test, it is important to erase the last trip data from the memory of the trip unit.

**** IMPORTANT ****

Erase the last trip data from the memory of the trip unit after completing the primary injection tests.

To erase the memory in the trip unit after completing the primary injection tests, use one of the following methods:

Method 1:

- 1) The trip unit can be either off or powered-up.
- 2) Push the "REVIEW" button to display the last trip data.
- 3) While the last trip data is flashing, push and hold both the "UP" and "DOWN" push buttons.
- 4) Continue to hold the "UP" and "DOWN" buttons and push the "SAVE" button. Release all buttons. The following will be displayed:

NO LAST TRIP

www.ElectricalPartManuals.com

Method 2:

- 1) The trip unit should not be powered-up (i.e. the display should be OFF).
- 2) Connect the security key. See section 4.2.
- 3) Press and hold in both the "UP" and "DOWN" push buttons simultaneously.
- 4) While continuing to depress the "UP" and "DOWN" push buttons, press the "REVIEW" push button to turn the trip unit on.
- 2) Release all push buttons. The following will be displayed:

DECOMMISSION?

- 5) Pressing the "UP" push button will **ERASE** the pick-up and delay settings. Pressing the "DOWN" push button will **NOT** erase the pick-up and delay settings.
- 6) The following will be displayed next:

ERASE TRIP DATA?

- 7) If the last trip data is to be erased, press the "UP" push button. If the data is **not** to be erased, push the "DOWN" push button.
- 8) Remove the security key. Press the "REVIEW" push button to confirm any changes.

**** IMPORTANT ****

If the last trip data is not erased after the primary injection test, the operating personnel may later assume that the breaker interrupted a fault at some time in the past when they use the "TARGET RECALL" feature. The trip counter will also have misleading data.

11. Ratings

Ambient Temperature:

Trip Unit:
-4°F (-20°C) to 150°F (65°C)

LCD Display:
Standard Temp, Super Twist
32°F (0°C) to 122°F (50°C)

Humidity:

95% non-condensing

Conformal Coating:

Acrylic conformal coating,
HumiSeal type 1B15H
or Konform type AR2000

Enclosure:

Extruded aluminum housing
Nominal overall dimensions:
6.76 X 3.84 X 2.28 inches
172 X 100 X 58 millimeters

Battery:

Ultralife Model U9VL-FP
1200 mAh Lithium/Manganese Dioxide
Ten-year rated shelf life
Non-Rechargeable

12. Warranty

A conditional 2-year warranty is offered with each AC-PRO trip unit.

Contact Utility Relay Company for full details.

www.ElectricalPartManuals.com

13. Time-Current Curves

The Time-Current curves are shown in Section 15.

For all the functions except U/B, the curves are shown on log-log graph with seconds in the vertical direction and current in the horizontal direction.

Overload and fault currents are shown as multiples of the LT pick-up setting. Ground fault current is shown as a percentage of the CT rating.

Tolerances for the Pick-Up bands are ± 10% in the current direction. Tolerance for LT, ST I²T and GF I²T trip times are + 23% and -17% in the time direction.

The curves for the following time bands:

- LT
- ST I²T
- GF I²T

are based on the following equation:

$$I^2T = \text{Constant}$$

Where: I is current in amps
 T is time to trip in seconds (center of the band)

The curves for the U/B function are shown on a semi-log graph with seconds in the vertical direction and unbalance in percent in the horizontal direction.

Tolerance for U/B function is given in Section 13.4.

When performing trip-timing tests using a primary injection test set, the trip time at various test currents can be determined by calculation as explained in Sections 13.1, 13.2 and 13.3.

13.1 LT Trip Time

For overload currents, the "I²T = Constant" equation can be restated as follows:

$$T = \frac{TBC_{LT}}{X^2}$$

Where: T = time to trip in seconds (center of the band)

X = current in multiples of the LT pick-up setting

TBC_{LT} = the LT Time Band Constant
 = 36 X LT time band setting

**** NOTE ****
 The LT Time Band Constant (TBC_{LT}) is by definition 36 times the LT Time Band Setting in seconds.

EXAMPLE #1:

CT Rating	1600A
LT pick-up	1200A
LT time band	20.0S
Overload Current	3600A

$$TBC_{LT} = 36 \times \text{LT Time Band Setting} \\ = 36 \times 20.0 \\ = 720$$

$$\text{and } X = \frac{\text{overload current}}{\text{LT Pick-Up}} = \frac{3600A}{1200A} = 3$$

therefore:

$$\text{trip time} = T = \frac{TBC_{LT}}{X^2} \text{ or } \frac{720}{3^2} = \frac{720}{9} \\ = 80 \text{ seconds}$$

**** IN SUMMARY ****

To calculate the LT trip time:

- 1) Calculate the LT Time Band Constant (TBC_{LT})
- 2) Calculate "X" where
 $X = \frac{\text{overload current}}{\text{LT Pick-Up Setting}}$
- 3) Solve the equation:
 $\text{trip time(sec)} = \frac{TBC_{LT}}{X^2}$

www.ElectricalPartManuals.com

13.2 ST Trip Time

With I²T **OFF** or for currents greater than 10 X LT Pick-Up Setting, the ST trip time is a constant equal to the ST Time Band setting.

With I²T **ON** and for currents less than 10 X LT Pick-Up Setting, the ST trip time is determined by the following equation:

$$T = \frac{TBC_{ST}}{X^2}$$

Where: T = time to trip in seconds (center of the band)

X = current in multiples of the LT pick-up

TBC_{ST} = the ST Time Band Constant

****** NOTE ******

The ST Time Band Constant (TBC_{ST}) =
 40 for the .40S Time Band
 30 for the .30S Time Band
 20 for the .20S Time Band
 15 for the .15S Time Band
 10 for the .10S Time Band
 7 for the .07S Time Band

EXAMPLE #2:

CT Rating	1600A
LT pick-up	1200A
ST pick-up	6000A
ST time band	.20S I ² T ON
Overload Current	7200A

TBC_{ST} = 20

and X = $\frac{\text{overload current}}{\text{LT Pick-Up}} = \frac{7200A}{1200A} = 6$

therefore:
 trip time = T = $\frac{TBC_{ST}}{X^2}$ or $\frac{20}{6^2} = \frac{20}{36}$
 = .556 seconds

****** IN SUMMARY ******

To calculate the ST I²T trip time:

- 1) Determine the ST Time Band Constant (TBC_{ST})
- 2) Calculate "X" where
 $X = \frac{\text{overload current}}{\text{LT Pick-Up}}$
- 3) Solve the equation:
 trip time(sec) = $\frac{TBC_{ST}}{X^2}$

www.ElectricalPartManuals.com

13.3 GF Trip Time

With I²T **OFF** or for ground fault currents greater than 2 times the CT rating, the GF trip time is a constant equal to the GF Time Band setting.

With I²T **ON** and for currents less than 2 times the CT rating, the GF trip time is determined by the following equation:

$$T = \frac{TBC_{GF}}{X_{GF}^2}$$

Where: T = time to trip in seconds (center of the band)

X_{GF} = $\frac{\text{ground fault current}}{\text{CT rating}}$

TBC_{GF} = the GF Time Band Constant

**** NOTE ****

The GF Time Band Constant (TBC_{GF}) =

- 2.0 for the .50S Time Band
- 1.6 for the .40S Time Band
- 1.2 for the .30S Time Band
- 0.8 for the .20S Time Band
- 0.4 for the .10S Time Band

EXAMPLE #3:

CT Rating	1600A
LT pick-up	1200A
GF pick-up	640A
GF time band	.20S I ² T ON
Ground Fault Current	800A

TBC_{GF} = 0.8

and $X_{GF} = \frac{\text{ground fault current}}{\text{CT Rating}} = \frac{800A}{1600A} = 0.5$

therefore:

trip time = T = $\frac{TBC_{GF}}{X_{GF}^2}$ or $\frac{0.8}{(0.5)^2} = \frac{0.8}{.25} = 3.20 \text{ sec}$

**** IN SUMMARY ****

To calculate the GF I²T trip time:

- 1) Determine the GF Time Band Constant (TBC_{GF})
- 2) Calculate "X_{GF}" where
X_{GF} = $\frac{\text{ground fault current}}{\text{CT Rating}}$
- 3) Solve the equation:
trip time(sec) = $\frac{TBC_{GF}}{X_{GF}^2}$

13.4 U/B Trip Time

U/B is calculated as follows:

$$U/B = \frac{(I_{NL} - I_{NS})}{I_{NL}} \times 100\%$$

Where:

I_{NL} = Largest Phase current

I_{NS} = Smallest Phase current

The U/B function is defeated if any two phase currents are less than 10% of the CT rating.

The tolerance for the U/B Pick-Up is ± 10 percentage points. An U/B Pick-Up of 20% would have a tolerance of 10% to 30% unbalance. An U/B Pick-Up of 50% would have a tolerance of 40% to 60% unbalance.

The U/B trip time is a definite time as shown on the U/B TCC in Section 15.

The tolerance for the U/B trip time is ± 10% of the setting.

www.ElectricalPartManuals.com

14. Error Message Summary

The following is a summary of the possible error messages and what action is necessary to correct the problem.

14.1 Actuator Not Connected

When the actuator is not connected or is open circuited, the following message will be displayed:

NO ACTUATOR

All push buttons are disabled. To return to normal operation, a functioning actuator must be connected.

14.2 Memory Error

The micro-controller continuously monitors its memory. When a discrepancy occurs, the following message will be displayed:

MEMORY ERROR

All push buttons are disabled. The micro-controller must be replaced. Contact Utility Relay Company for more information.

www.ElectricalPartManuals.com

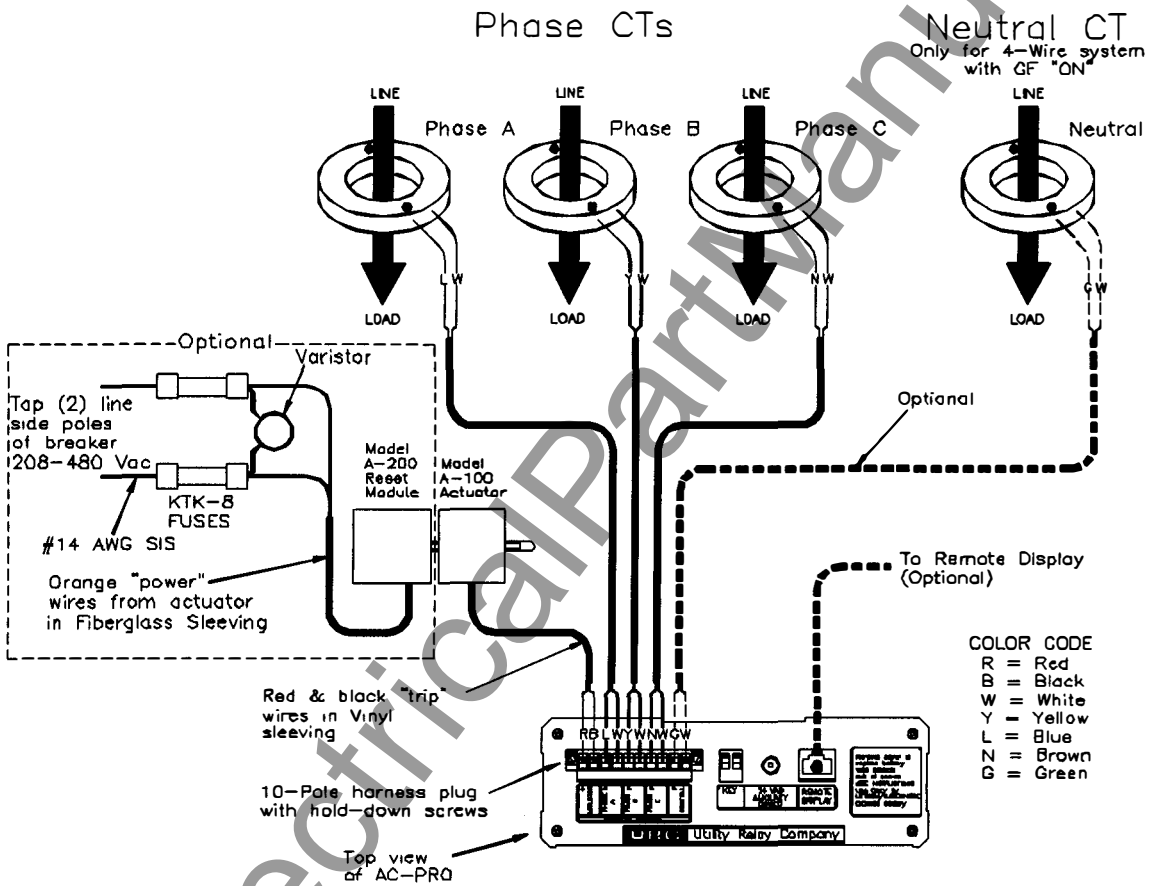

Figure 15.1, Wiring Diagram

www.ElectricalPartManuals.com

INTENTIONALLY LEFT BLANK

www.ElectricalPartManuals.com

www.ElectricalPartManuals.com

AC-PRO Trip Unit
Overload Time Current Curve

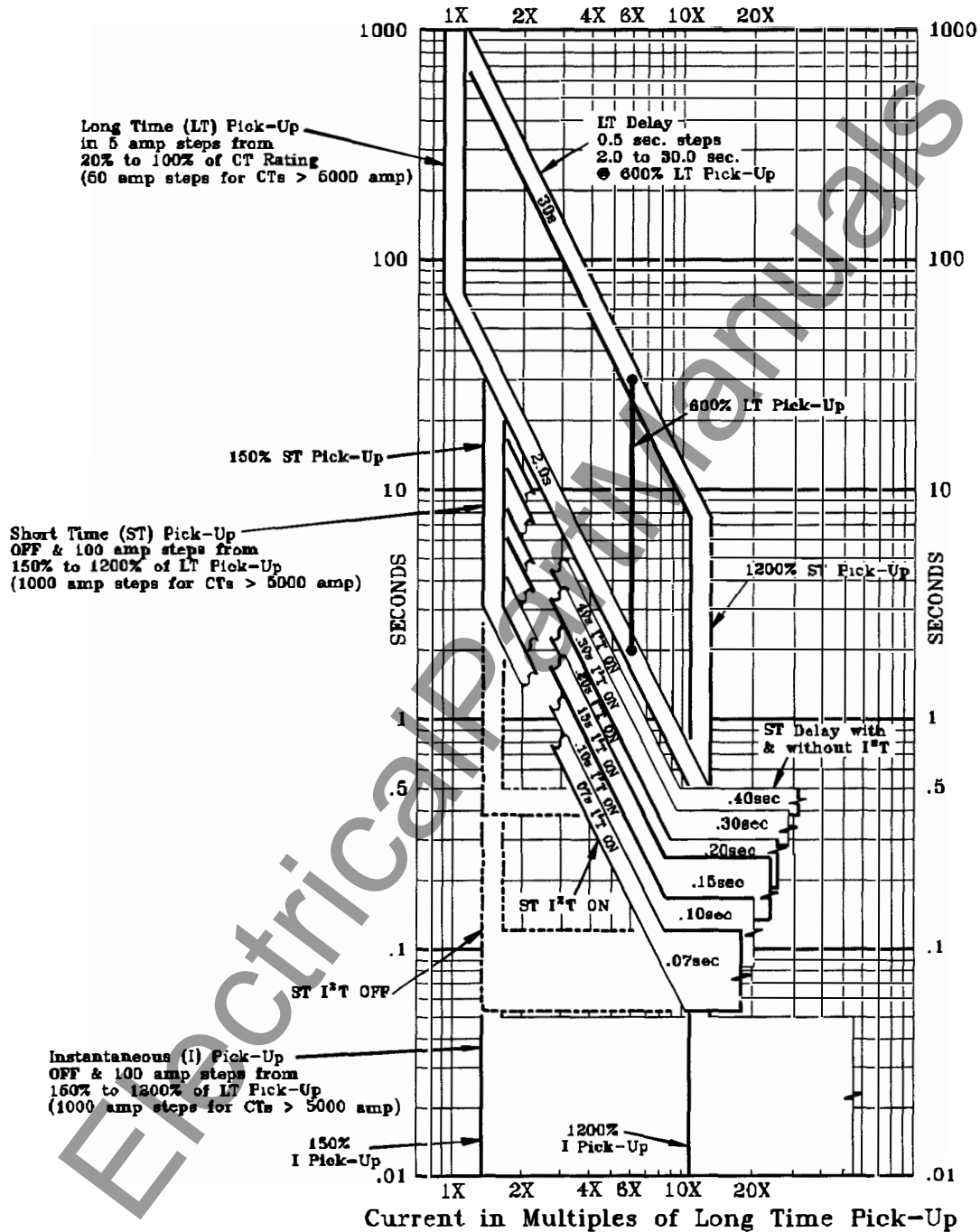

Utility Relay Company

Chagrin Falls, Ohio 44023

888-289-2864 www.utilityrelay.com

Rev. 0302

Figure 15.2 Overload TCC

www.ElectricalPartManuals.com

INTENTIONALLY LEFT BLANK

www.ElectricalPartManuals.com

www.ElectricalPartManuals.com

AC-PRO Trip Unit

Unbalance Time Current Curve

Ground Fault Time Current Curve

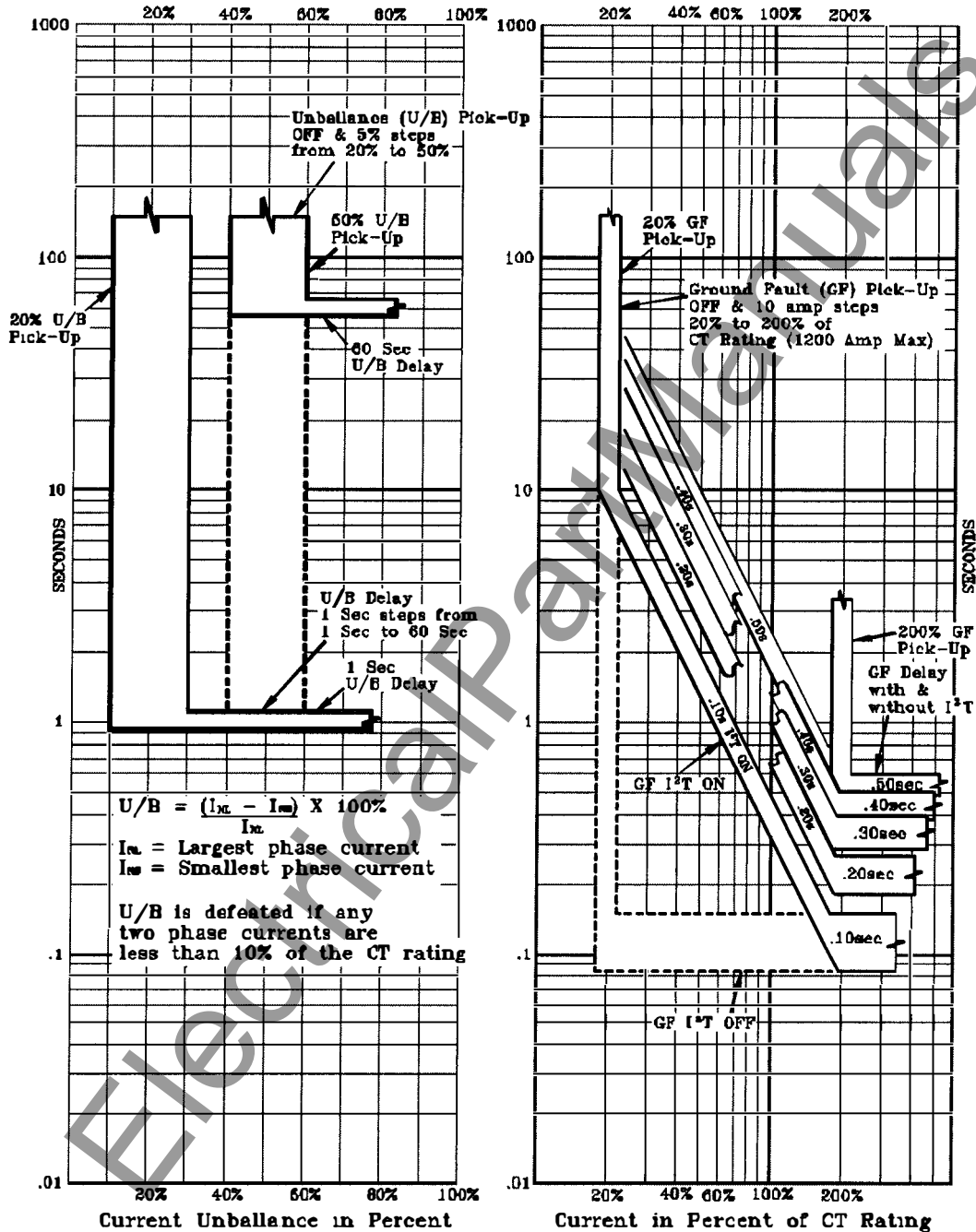

Utility Relay Company

Chagrin Falls, Ohio 44023

Rev. 0302

888-289-2864 www.utilityrelay.com

Figure 15.3, U/B & GF TCC

www.ElectricalPartManuals.com