

991 674A

installation
instructions

molded case
circuit breaker
CJ 400
CJ 600

www.ElectricalParts.com

cable connection

cable range

■ rating 400A :

- 1 cable 2/0 AWG - 600 MCM Cu
- 1 cable 4/0 AWG - 500 MCM Al

■ rating 600A :

- 1 cable 2/0 AWG to 500 MCM Cu
- 1 to 2 cables 2/0 AWG to 350 MCM Cu
- 1 to 2 cables 4/0 AWG to 500 MCM Al.

strip length

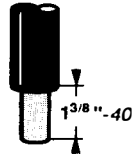

1 remove front terminal cover (line side only)

2 connect first cable to pressure terminals and tighten it

3 connect second cable if any and tighten it to 375 lb.in. Replace front terminal cover.

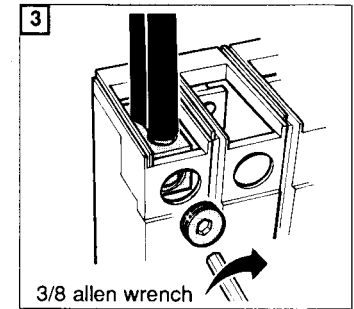
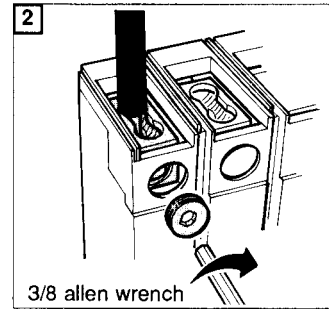
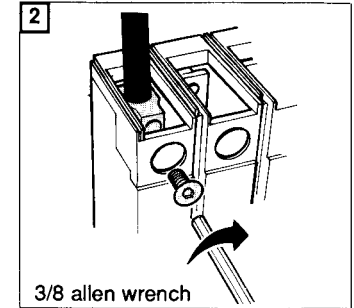
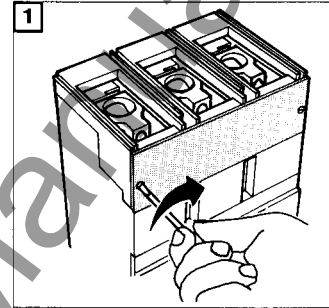
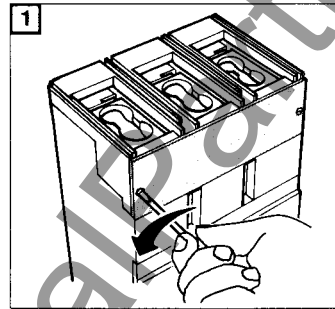

bus bar connection

1 remove front terminal cover

2 connect bars to terminals and tighten to 275 lb.in and replace front terminal cover (line side only 9 lb.in).

drilling of the bars

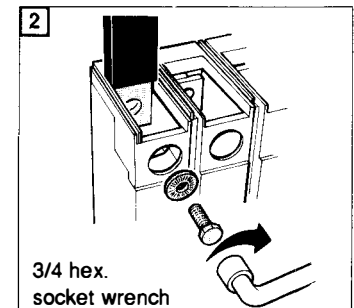
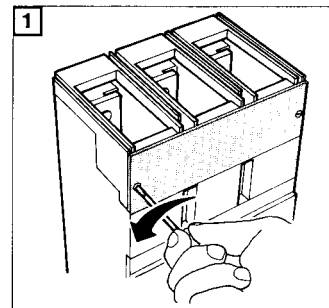
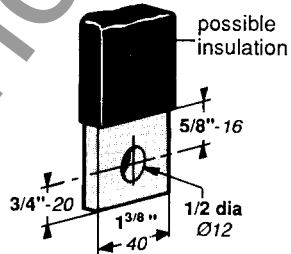

modification from bus bar to cable termination

1 remove front cover (line side only)

2 slide the brown U-shaped shield down into the cavity (line side only)

3 place terminals in breaker.
caution: place the terminal as indicated with the chamfered edge facing the outer side of the breaker

4 tighten flat head mounting screws to 275 lb.in

5 install the two binding screws

6 replace front cover (line side only).

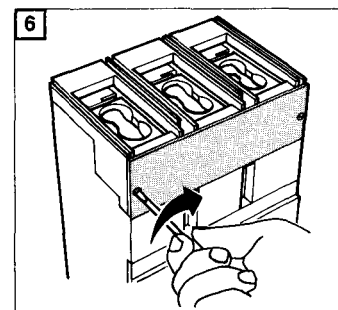
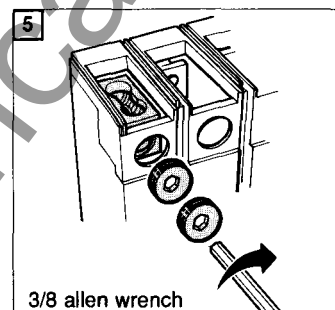
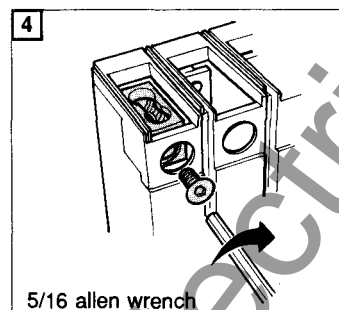
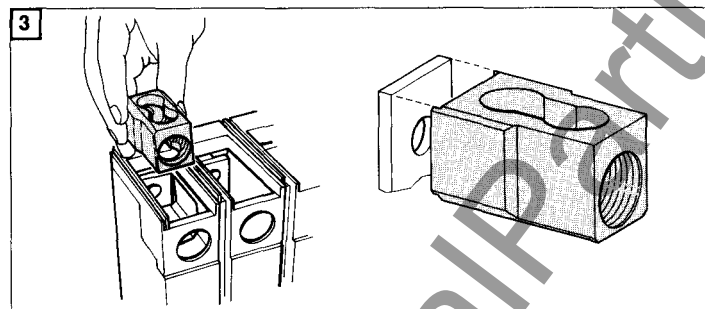
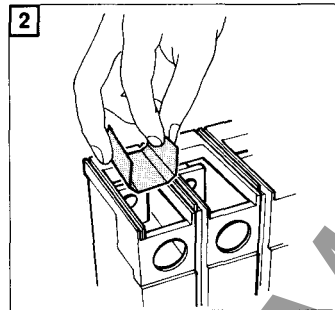
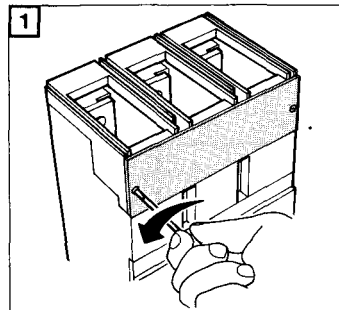

accessories

▒ internal gutters

→ possible wire exits

▬ knock outs
break only those required
depending on the desired
direction of wiring

location of electrical accessories on fixed mounting circuit breakers

shunt trip
terminal C1-C2
undervoltage trip
terminal D1-D2

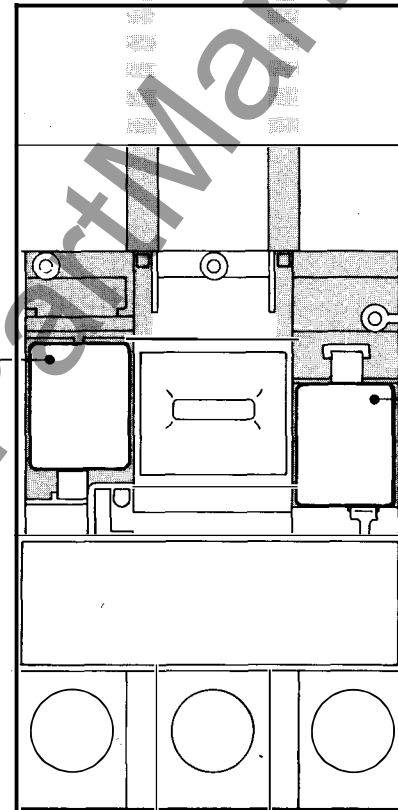

3 auxiliary +
1 alarm switch
cat. no - 36402
3 auxiliary switches :
11-12-14, 21-22-24,
31-32-34
1 alarm switch
91-92-94
2 auxiliary switches
cat. no - 36404
11-12-14, 31-32-34
1 auxiliary +
1 alarm switch
cat. no - 36405
auxiliary switch
31-32-34
alarm switch
91-92-94

accessories
(cont'd)

location of terminal number on secondary disconnects of plug-in circuit breakers

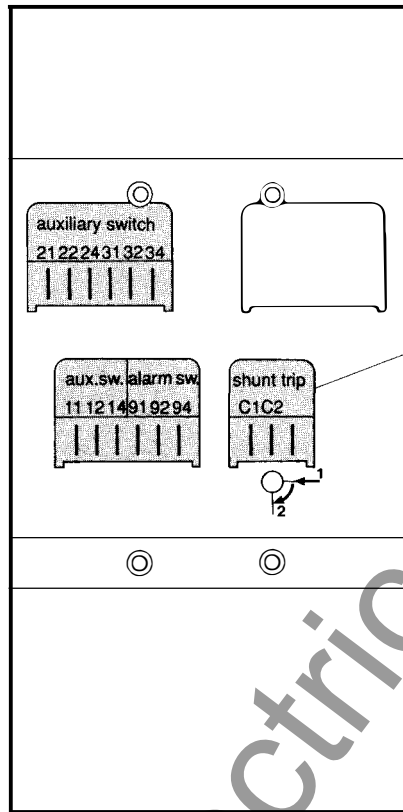

under-voltage
D1D4

shunt trip - undervoltage trip device

1 ensure that breaker is discharged or trip it by pushing the red trip button **A**.
Remove the screws **B** and open front cover

2 shunt trip and undervoltage trip must be installed in left side ONLY

3 slide the upper side of the accessory below the plastic hook in such a position that you have the wire fixing screws facing you.
Push down the lower side straight down until it is latched by the leaf spring.

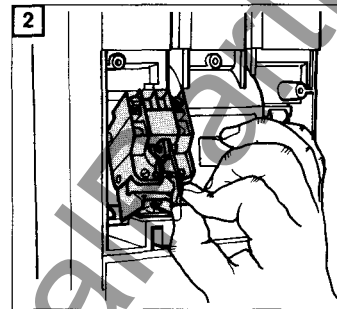
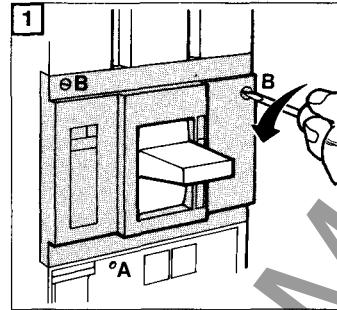

electrical data shunt trip

catalog number	voltage	inrush current
36437	60Hz 120V	2.5A
36446	240V	0.3A
36446	480V	0.5A
36447	600V	1A
36434	DC 12V	3.8A
36435	24V	11A
36436	48V	5.5A
36437	125V	2.5A

undervoltage trip

catalog number	voltage	sealed-in current
36418	60Hz 120V	0.050A
36419	240V	0.020A
36420	480V	0.014A
36421	600V	0.010A
36410	DC 24V	0.037A
36411	48V	0.022A
36412	125V	0.014A

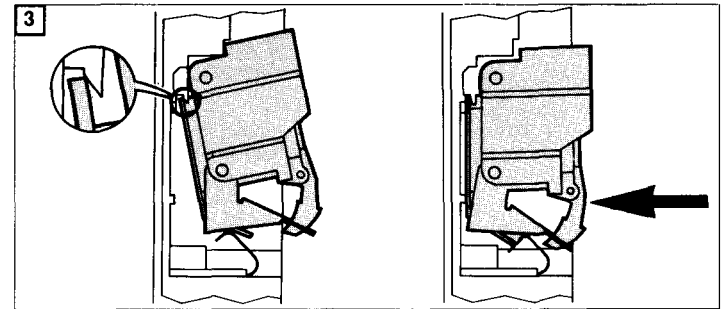

4 electrical check

note: if the breaker is not to be connected jump to step 7

5 connect wire leads to auxiliary terminals

6 knock out one of the precut grooves depending on the desired direction of wiring

7 replace the front cover, making sure the wire leads are properly installed in the grooves and will not be pinched by the cover

8 add accessory identification and wiring label to left side of the circuit breaker.

5 shunt trip

- a - reset and turn circuit breaker ON
- b - attach test circuit to C1 and C2 terminals
- c - energize shunt trip device at 55% (AC) or 75% (DC) of the rated name plate voltage. The circuit breaker should trip

undervoltage trip

- a - breaker in TRIPPED position
- b - attach test circuit to D1 and D4 terminals
- c - energize undervoltage trip device at 85% of the marked rated voltage
- d - reset and turn circuit breaker ON
- e - turn test voltage OFF. The circuit breaker should trip

5 shunt trip

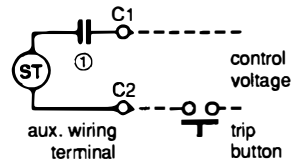

undervoltage trip

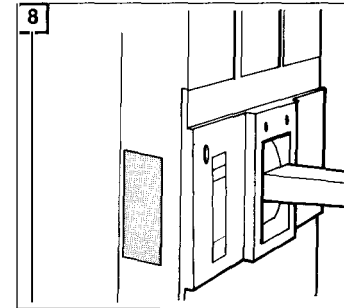
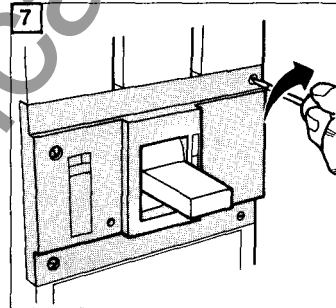
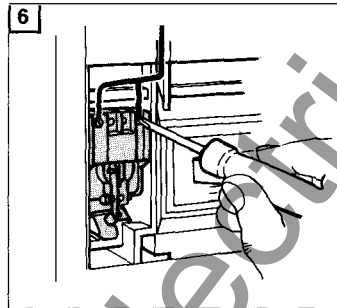
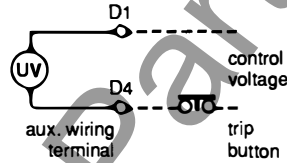

motor operator

1 connect wire leads to terminals according to the schematic diagram below :

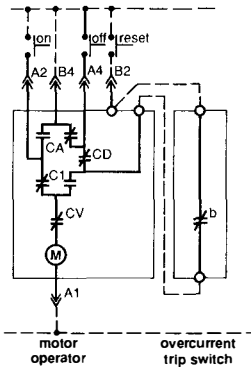

note : schematic diagram using resetting push-button for remote resetting. For other diagrams refer to technical manual.

caution : control diagram shall be designed to interlock remote on and off orders.

2 shunt trip, undervoltage trip and auxiliary switches can be field installed afterwards. Installation requires to remove the motor operator from the breaker :

- ① - unscrew the fixing screw
- ② - rock the mechanism
- ③ - unscrew the 2 fixing screws
- ④ - see page 6 for installing internal accessories.

3 replace the motor operator.
caution : operate up and down the manual operating handle to engage the fork around the toggle.

4 route the accessory wire leads through the window.

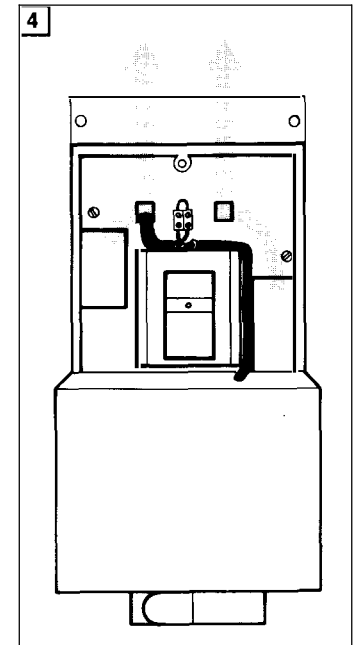
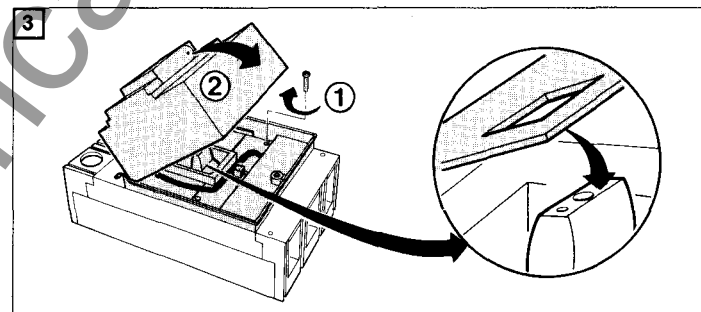
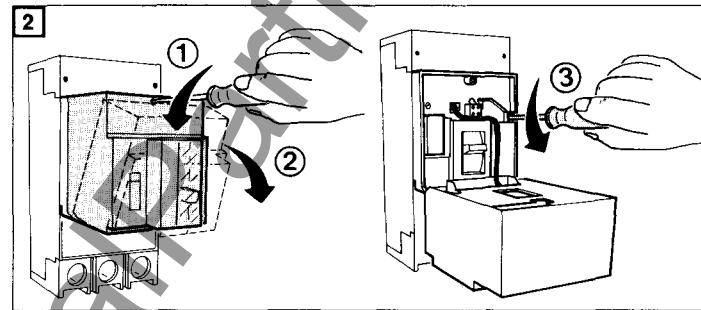
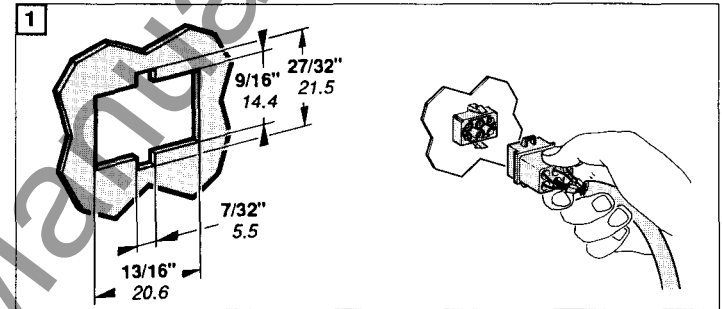

settings

The values of settings of current and time delay shall be determined after analysis of the power system.

After trip unit rotary switches have been adjusted to the proper settings, make sure to replace the trip unit transparent cover keeping an access to RESET push button. Refer to main technical manual for characteristics and time-current curves.

resetting

caution : in case of tripping due to overcurrent or ground fault, the fault must be cleared before any attempt of resetting.

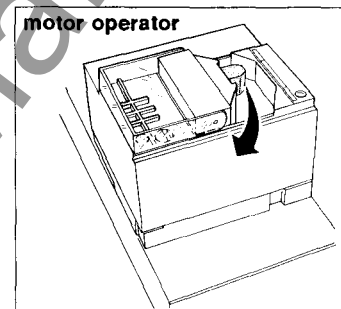
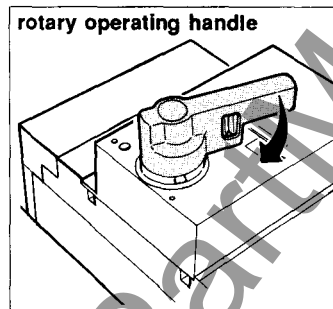
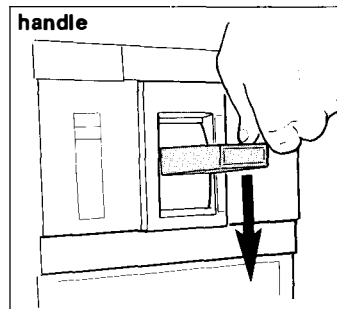

padlocking

padlocking of :	cat. no.
handle	44936
motor operator	standard

accommodates up to four padlocks
shackle diameter : 1/4 to 5/16" dia.

handle

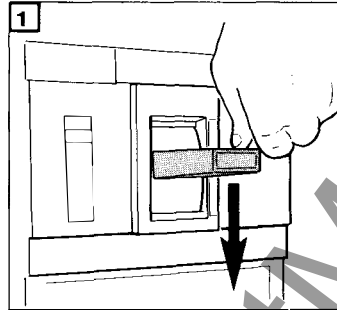

1 open the circuit breaker and insert the adaptor into the slot

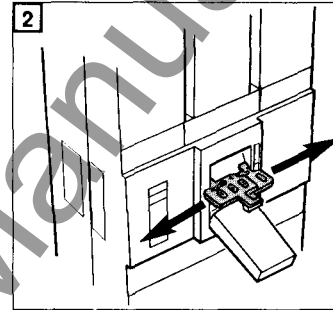

2 extend the two parts making sure that the circuit breaker is properly locked

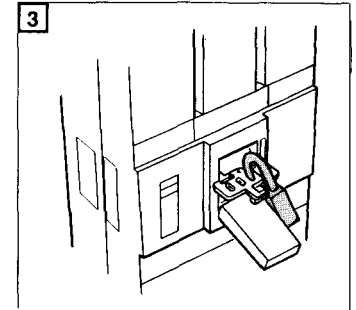

3 insert one to four padlocks

motor operator

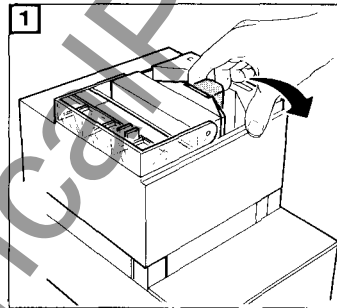

1 open the front transparent cover and turn the breaker OFF

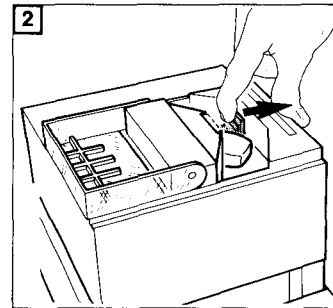

2 pull the built-in padlocking device

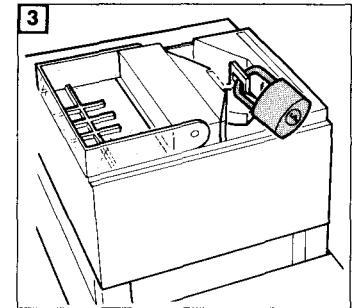

3 insert one to four padlocks

padlocking (cont'd)

Mounted on the breaker or on a door, it accommodates as standard up to three padlocks to lock the handle in the OFF position. However, a knockout tab can be removed to allow the locking of the handle in the ON position (3 to 6)

note : due to the trip free mechanism padlocking in such a position will not prevent the circuit breaker from tripping under overcurrent conditions. The handle will continue to indicate ON.

In the third position (6) of padlocking the handle passes beyond the possible door cutout enabling to padlock in the same time the door and the breaker.

rotary operating handle

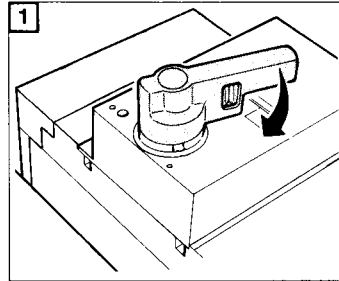

1 open the circuit breaker and push the padlocking device

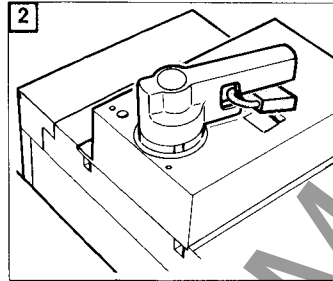

2 insert one to three padlocks
skackle diameter : 1/4 to 5/16

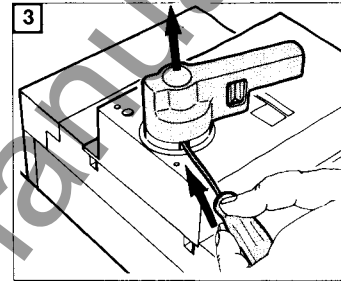

3 modification of the way of padlocking (ON or OFF) requires to remove the handle

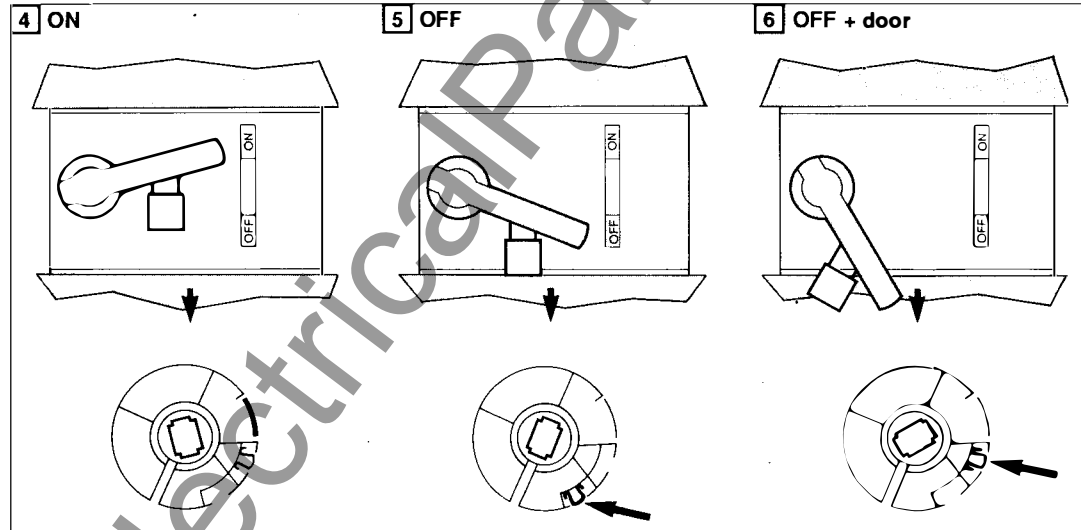

www . ElectricalPartManuals . com