

RMS CURRENT MEASUREMENT

with

SURE TRIP RETRO KITS

Circuit Breaker

Solid State Controls

with

RMS-2002 LOGIC

The **SURE TRIP** Solid State Tripping Systems Have Been Designed, Tested
And Produced To all Applicable NEMA and UL Standards.

PATENT NO. 4,866,557

“ANSI C37.59”

SURE TRIP, INC
24048 North Carolina Highway 73
Albemarle, North Carolina 28001

TOLL FREE: (877) 382-5864
(800) 382-5864

FAX: ♦ (905) 315-8892
(704) 983-6128

E MAIL: RMS2002@suretrip.com

www.ElectricalPartManuals.com

RMS-2002 SOLID STATE BREAKER RETRO-KITS

RMS-2002 RETRO-KITS

The modern alternative for circuit breaker upgrading instead of replacement, at a fraction of the cost. **RMS-2002 RETRO-KITS** are comprised of the highest quality engineered components to easily retrofit circuit breakers regardless of the original quality or manufacturer.

RMS-2002 RETRO-KITS OFFER THESE EXCLUSIVE FEATURES

1. Circuit design provides universality of time-current settings to allow one model for the full range of current settings required by normal applications.
2. Rotary switch adjustments provide precise, repeatable settings.
3. Each printed circuit board is specially treated to prevent contamination and signal leakage.
4. Metal enclosure, as standard, to shield against noise, magnetic interference and contamination.
5. Target diagnostic circuitry is designed to provide maximum protection capability to reduce system downtime by analyzing any over current fault and visually identifying it's cause as an overload, short circuit or ground fault. Additionally, no batteries are required to maintain trip indication.
6. A Long Time pickup timing indicator, as standard, to aid in identifying an over current condition in process.
7. Circuit design allows both local and remote fault indication.
8. An I squared T Short Time switch, as standard, to provide maximum coordination with the inrush currents of motors and transformers.
9. Design circuitry built for protection against RF radiation, transient voltage, and harmonic problems.
10. Current sensors are epoxy encapsulated as standard.
11. Current sensors are designed to mount on the rear of the breaker for maximum ease of retrofitting circuit breakers.
12. All Actuators are manufactured to meet a set of stringent design criteria. This allows the actuators to be mounted on a wide range of circuit breakers with minimal expense.
13. Actuators are manufactured with metals that help eliminate corrosion to prevent inoperable mechanisms.
14. Portable test set to facilitate in-house secondary testing of in service **SURE TRIP** units at full current rating 0-60 amps.

The **RMS-2002 Product Line** allows our customers to retro-fit any circuit breaker with the features required for all the various applications demanded with both cost and feature benefits which are unprecedented in the marketplace.

RMS MEASUREMENT OF SINUSOIDAL AND NON-SINUSOIDAL CURRENT

The **RMS-2002 LOGIC CONTROL** monitors current overloads accurately for electrical distribution systems including AC & DC variable speed drives, induction heating, and other loads that cause Non-Sinusoidal wave distortion.

CURRENT SENSORS

The current sensors are designed to be mounted on the rear bus-bar stabs of the circuit breaker. They produce a current output proportional to the load current of the breaker. Since the **RMS-2002 LOGIC CONTROL** requires a nominal signal of 5A per breaker frame, the logic is universal to any breaker frame in the industry by simply changing the sensors. The following current sensor ratings are available as standard. Other tap ratings are available as a special order.

| FRAME SIZE AMPERES | SENSOR TAP | AMPERE RANGE |
|--------------------|------------|--------------|
| 225 | 225/100 | 40-225 |
| 600 | 600/225 | 90-600 |
| 1600 | 1600/800 | 320-1600 |
| 3200 | 3200/1600 | 640-3200 |
| 4000 | 4000/1600 | 640-4000 |

The **RMS-2002 CONTROLS** are universally adjustable and are compatible with any 5 amp secondary current sensor.

ACTUATORS

Actuators are manufactured to mount on all standard breaker frames with minimal time and expense. With a minimum of 6 lbs. latching and tripping, they will trip the breaker when required and at the same time, eliminate nuisance tripping.

OEM REPLACEMENT TRIP UNIT

The **RMS-2002** can be adapted to work with existing current sensors that may already be located on the circuit breaker. This replacement trip unit is supplied with various full load pick up characteristics to enable the replacement of obsolete OEM trip devices. By utilizing the existing current sensors and/or magnetic latch, the circuit breaker can be upgraded to modern technology with minimal cost and downtime. Unit requires a nominal current of 1 amp or greater to function.

www.ElectricalPartManuals.com

TEST SET

A full function test set has been developed for testing any of the **SURE TRIP LOGICS**. It will check the time current characteristics of the logic programmer at an infinite number of points along its curves, test the programmer diagnostic circuitry, and actuator operation. The test set is a rugged, lightweight, and portable device designed specifically with the service man in mind.

*The Test Set operates, at full load, at more than 60 amps when attached to the RMS 85 or **RMS-2002** Logics. The Test Set is designed to handle current amplitudes according to the Long Time trip curves. Repetitive high current testing may cause excessive heating.

RMS-2002 SOLID STATE PROGRAMMER

The **RMS-2002** solid state programmer is a static trip device designed to provide more precise tripping characteristics, when retrofitted on low voltage air circuit breakers, than the thermal magnetic trip units, which it replaces.

The **RMS-2002** programmer comes in a single box configuration, which is illustrated in Drawing 2 on page 8. The unit has Long Time, Short Time, and Instantaneous tripping functions as standard equipment. 1 square T function, 12x Discriminator, Long Time pick up light, Trip indicators, and a trip indicator reset button are also standard.

The following optional equipment is available on the trip unit at an additional cost as shown on the price list. These include a Ground Fault function, Amp Tap, and Functions Active selector. The following drawings are available on the respective pages.

Drawings Legend

| | | |
|-----------|----------|---|
| Drawing 1 | -Page 6 | -Function Block Diagram |
| Drawing 2 | -Page 7 | -Front Panel Layout |
| Drawing 3 | -Page 12 | -Wiring Diagram for Systems without Ground Fault Protection |
| Drawing 4 | -Page 12 | -Wiring Diagram for 3 Wire Systems with Ground Fault Protection |
| Drawing 5 | -Page 12 | -Wiring Diagram for 4 Wire Systems with Ground Fault Protection |
| TCC | -Page 15 | -Time vs. Current Characteristic Curves |

Specific pickup points for each function are shown in drawing 2, while the basic functions are described in the following table. Examples are given in each description.

LEGEND TO DRAWINGS 2

| | |
|--------------------------|--|
| 1. Long Time Pick-Up | 8. Trip Indicating Targets and Reset |
| 2. Long Time Pick-Up LED | 9. Option-Functions Active Selector |
| 3. Long Time Delay Band | 10. Option-Amp Tap |
| 4. Short Time Pick-Up | 11. Option-Ground Fault Burden Setting |
| 5. Short Time Delay Band | 12. Option-Ground Fault Pick-Up |
| 6. 1 Square T Position | 13. Option-Ground Fault Delay |
| 7. Instantaneous Pick-Up | |

#1 LONG TIME PICKUP

The Long Time Pick-up switch provides an additional current adjustment capability for the breaker with six steps from 40% to 100%. Changing this setting does not affect any other function.

Example: 1600 amp current sensor, with Long Time Pick-up set at .4, the current rating on long time is now at 640 amps.

#2 LONG TIME DELAY

This three-step time adjustment varies the time that the breaker will operate under sustained overload without tripping.

#3 LONG TIME TIMING LIGHT

This feature provides visual indication of an overload condition and pick-up of the long time timing function.

#4 SHORT TIME PICK-UP

This function adjustment controls the amount of high current the breaker will carry for short periods of time without tripping. This function can be set at 2 to 10 times current sensor rating.

Example: 1600 amp current sensor, Short Time Pick-up switch set at 6 times provides a 9,600-amp short time trip setting.

#5 SHORT TIME DELAY

This three-step delay adjustment provides a further coordination between circuit breakers. It allows the breaker a time interval before responding to the selected short circuit current levels.

www.ElectricalPartManuals.com

#6 SHORT TIME I SQUARE T FUNCTION

The Short Time I Square T switch provides the ability of introducing an additional energy ramp into the short time function delay. This function provides maximum coordination benefits, especially for motor start applications. This allows the short time function to be set at lower levels so tripping will not occur on motor start.

#7 INSTANTANEOUS PICK-UP

This function determines the level at which the breaker will trip without intentional time delay. This instantaneous interruption occurs only as a result of a severe short circuit.

Example: 1600-amp current sensor, Logic Control set as above, with the 'INSTANTANEOUS' Pick-up switch set at '10' provides a 16,000-amp trip setting.

#8 FAULT TRIP INDICATORS with RESET SWITCH

These fault indicators identify the cause of an over-current trip and help to reduce system down time. Electronic flip-flag indicators analyze the fault and provide a memory of the trip. As an option, fault indicators can be remote mounted and wired to the breaker. The "Indicator Reset" switch can be used to reset the trip indicators after a fault condition.

#9 FUNCTION ACTIVE SELECTOR-OPTION

Provides the installer and the end user the ability to configure the unit according to the specific needs of the power system that it has been installed on. Also allows the unit to be adapted to the changing requirements of the system, thus eliminating the need to special order a unit without either the 'Instantaneous' or 'Short Time' function.

Example: 1600-amp current sensor, Logic Control set as above, with the 'FUNCTIONS ACTIVE' switch set at 'LI', the logic will not trip due to a 'Short Circuit' condition until the current level exceeds 16,000-amp.

#10 AMP TAP SWITCH -OPTION

This three-step adjustable ampere setting from 50% to 100% varies the level of current the logic receives from the current sensor. Changing this setting has the same effect as changing the value of the current sensor. Note when testing single phase you must maintain 30% of the sensor tap rating to maintain tolerance.

Example: 1600-amp current sensor, Amp Tap switch set at .5, the logic control monitors 800-amp maximum continuous current. Long time, short time, and instantaneous pick-ups are coordinated to 800-amp. The Logic must have 240 amp to remain in tolerance. The .4 and .52 Long Time Pick-Up will be out of the +/- 10% tolerance at the optional .5 Amp Tap setting when testing on single phase.

#11 GROUND BURDEN SETTING -OPTION

This six-step adjustable setting allows the ground function to be coordinated to the current sensor rating. The amp tap switch does not affect the Ground Fault settings of the logic.

#12 GROUND FAULT PICK-UP-OPTION

This six-step adjustable function controls the level of ground fault current (100 to 1200 amp) at which circuit interruption will occur, regardless of current sensor rating. This complies with the 1978 National Electric Code that no trip point exceeds 1200 amps.

#13 GROUND FAULT DELAY-OPTION

This three-step adjustment allows a predetermined time delay to the trip point once the ground fault pick-up has been reached.

#14 SENSOR TERMINAL BLOCK

Seven-position terminal block that allows the 'Logic Control' to be interfaced with the Sensors and Actuator.

TEST PROCEDURE FOR PROGRAMMABLE LOGIC CONTROLLER USING THE SURE TRIP SECONDARY TEST SET

1. Using the test set wiring harness, connect to the test set and to the logic box to be tested.
2. Verify all control settings are on the minimum settings and turn on the "Test Set".
3. Reset the "Trip Timer".
4. If an external ammeter is to be used, connect it to the "Test Set" at this time.
5. After testing a selected pick-up current or delay function, it is advised that the "Variac" control be returned to zero before proceeding to the next test.
6. When testing pick-up currents, start by selecting the lower range on the output. With the "Variac" at zero turn clockwise until the unit trips or the pick-up light turns on. If the logic controller does not trip at this setting, return the "Variac" to zero and select a higher range on the output and proceed with the test.
7. Testing of each function is described in more detail on the following pages.

The "Sample Test Chart" on page 11 gives a basic layout for recording the results of the test performed on a Logic Control. The form can be used when testing on secondary or primary.

www.ElectricalPartManuals.com

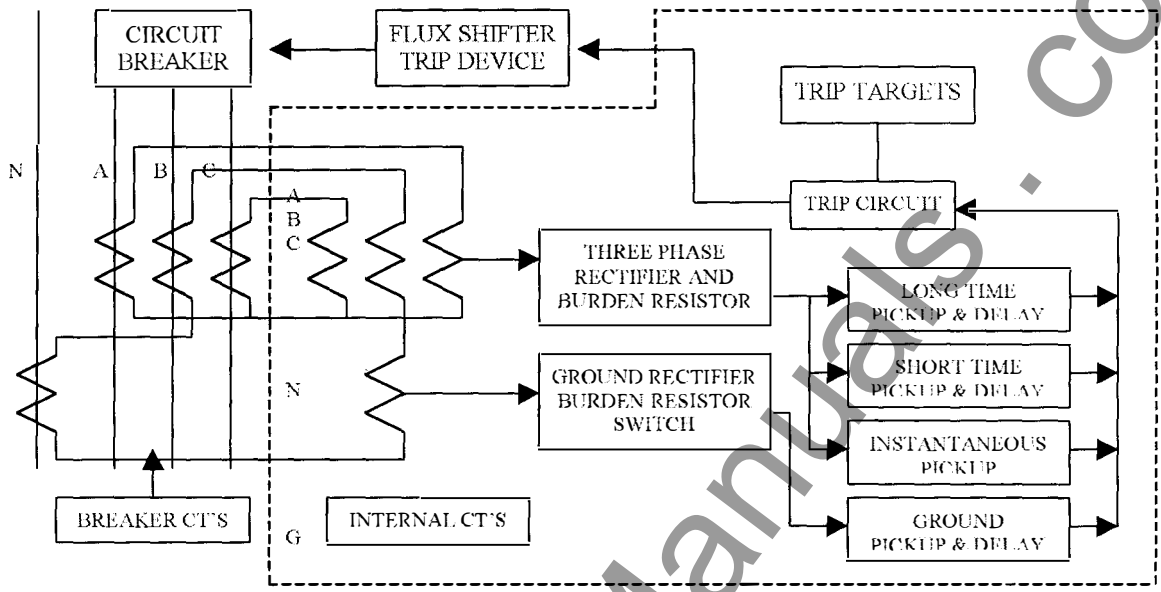

FUNCTION BLOCK DIAGRAM
DRAWING 1

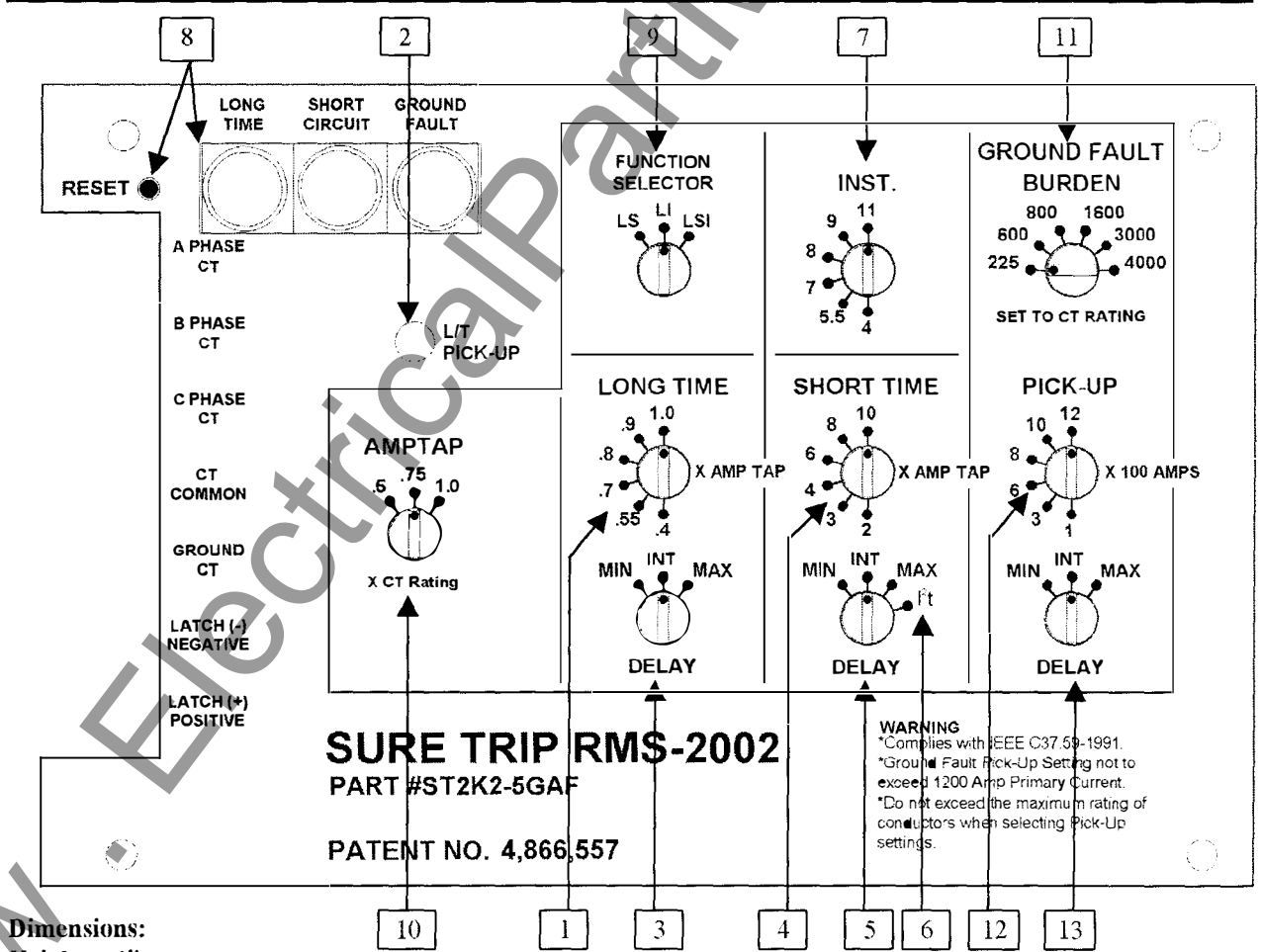

Dimensions:
Height = 4"
Width = 6", 7" with Mounting Tabs
Depth = 2-1/4"

Front Panel Layout For Control Box
Drawing 2

www.ElectricalPartManuals.com

LONG TIME FUNCTION

PICK-UP TEST

1. Test Set> Set the "Phase Selector" switch to the desired phase, the "Logic Selector" switch to "RMS-85", and the "Ground Fault" switch to the "Defeat" position.
2. Logic Box> Set the "Long Time Delay" switch to "MIN".
3. Test Set> "Reset" the Test Set, then "Test", slowly increase the "Variac" from "0" until the Long Time Pick-Up LED on the logic lights.
4. Observe the reading on the "Ammeter" just as the pick-up LED lights. Compare the reading to that of Chart 2A. Return "Variac" control to zero. Repeat for other phases or pick-up settings if desired.

LONG TIME DELAY

1. Test Set> Set the "Phase Selector" switch to the desired phase, the "Logic Selector" switch to "RMS-85", and the "Ground Fault" switch to the "Defeat" position.
2. Logic Box> Set the "Long Time Delay" to the desired setting, "MIN", "INT", or "MAX".
3. Test Set> "Reset" the Test Set, then "Test", adjust the "Variac" control to 300% of the long time pick-up. "Stop" the Test Set, "Reset", then "Test".
4. Test Set> When the logic trips, the "Open" lamp will light and the timer will quit timing. The "Trip Timer" will indicate the elapsed time. Compare this time to that of Chart 1A or the trip curves. Repeat for other phases or switch settings if desired.
5. Return the "Variac" to "0" and "Reset" the test set.

Chart 1A – Long Time Delay

| | | |
|---|-----|-----------|
| Set Secondary Current to 300% of Chart 2A. | Min | 8-12 Sec |
| | Int | 20-30 Sec |
| | Max | 60-90 Sec |

Chart 2A – Long Time Pick-up Currents

| Amp Tap | Test Current | .4 | .55 | .7 | .8 | .9 | 1.0 |
|---------|--------------|------|------|------|------|------|------|
| .5 | 2.50 | 1.00 | 1.38 | 1.75 | 2.00 | 2.25 | 2.50 |
| .75 | 3.75 | 1.50 | 2.06 | 2.63 | 3.00 | 3.38 | 3.75 |
| 1.0 | 5.00 | 2.00 | 2.75 | 3.50 | 4.00 | 4.50 | 5.00 |

SHORT TIME FUNCTION

PICK-UP TEST

1. Logic Box> Set Short Time Delay to "min" and long time delay switch to "MAX".
2. Test Set> Set the "Phase Selector" switch to the desired phase, the "Logic Selector" switch to "RMS-85", and the "Ground Fault" switch to the "Defeat" position.
3. Test Set> "Reset" the Test Set, then "Test", slowly increase the "Variac" from "0" until the logic trips and the "Open" lamp lights. Observe the reading on the "Ammeter" at the moment the breaker trips and compare this to the value in Chart 2B. Return the "Variac" to "0". Repeat for other phases or pick-up settings if desired.

SHORT TIME DELAY

1. Logic Box> Set long time delay to "MAX" and set the Short Time Delay to the desired setting, "MIN", "INT", or "MAX".
2. Test Set> Set the "Phase Selector" switch to the desired phase, the "Logic Selector" switch to "RMS-85", and the "Ground Fault" switch to the "Defeat" position.
3. Test Set> "Reset" the Test Set, then "Test", hold the "Calibrate", adjust the "Variac" to a current that is 150% of the short time pick-up current. Release the "Calibrate" switch, "Stop" the Test Set if necessary.
4. Logic Box> Reset the trip indicators and the actuator if desired.
5. Test Set> "Reset", then "Test". When the logic trips, the "Open" lamp will light and the timer will quit timing. The "Trip Timer" will indicate the elapsed time. Compare this time to that of Chart 1B or the trip curves. Repeat for other phases or switch settings if desired.
6. Test Set> Return the "Variac" to "0" and "Reset" the test set.

Chart 1B – Short Time Delay

| | | |
|--|-----|-------------|
| Set Secondary Current to 150% of Chart 2B | Min | .08-.17 Sec |
| | Int | .20-.32 Sec |
| | Max | .35-.50 Sec |

Chart 2B – Short Time Pick-up Currents

| Amp Tap | Test Current | 2 | 3 | 4 | 6 | 8 | 10 |
|---------|--------------|------|-------|------|------|------|------|
| .5 | 2.50 | 5.00 | 7.50 | 10.0 | 15.0 | 20.0 | 25.0 |
| .75 | 3.75 | 7.50 | 11.25 | 15.0 | 22.5 | 30.0 | 37.5 |
| 1.0 | 5.00 | 10.0 | 15.0 | 20.0 | 30.0 | 40.0 | 50.0 |

www.ElectricalPartManuals.com

INSTANTANEOUS FUNCTION

PICK-UP TEST

1. Logic Box> Set long time delay switch to "MAX".
2. Test Set> Set the "Phase Selector" switch to the desired phase, the "Logic Selector" switch to "RMS-85", and the "Ground Fault" switch to the "Defeat" position.
3. Test Set> "Reset" the Test Set, then "Test", slowly increase the "Variac" from "0" until the logic trips and the "Open" lamp lights. Observe the reading on the "Ammeter" at the moment the breaker trips and compare this to the value in Chart 2C. Return the "Variac" to "0". Repeat for other phases or pick-up settings if desired.

INSTANTANEOUS DELAY

1. Logic Box> Set long time delay to "MAX".
2. Test Set> Set the "Phase Selector" switch to the desired phase, the "Logic Selector" switch to "RMS-85", and the "Ground Fault" switch to the "Defeat" position.
3. Test Set> "Reset" the Test Set, then "Test", hold the "Calibrate", adjust the "Variac" to a current that is 150% of the instantaneous pick-up current. Release the "Calibrate" switch, "Stop" the Test Set if necessary.
4. Logic Box> Reset the trip indicators and the actuator if desired.
5. Test Set> "Reset", then "Test". When the logic trips, the "Open" lamp will light and the timer will quit timing. The "Trip Timer" will indicate the elapsed time. Compare this time to that of Chart 1C or the trip curves. Repeat for other phases or switch settings if desired.
6. Test Set> Return the "Variac" to "0" and "Reset" the test set.

Chart 1C – Instantaneous Delay

Set Secondary Current
To 150% of Chart 2C

No More Than
.06 Sec

Chart 2C – Instantaneous Pick-up Currents

| Amp Tap | Test Current | 4 | 5.5 | 7 | 8 | 9 | 11 |
|---------|--------------|------|------|------|------|------|-------|
| .5 | 2.50 | 10.0 | 13.8 | 17.5 | 20.0 | 22.5 | 27.50 |
| .75 | 3.75 | 15.0 | 20.6 | 26.3 | 30.0 | 33.8 | 41.25 |
| 1.0 | 5.00 | 20.0 | 27.5 | 35.0 | 40.0 | 45.0 | 55.00 |

GROUND FUNCTION-OPTION

PICK-UP

1. Logic Box> Set Ground Fault Delay to "min" and long time delay switch to "MAX".
2. Test Set> Set the "Phase Selector" switch to the desired phase, the "Logic Selector" switch to "RMS-85", and the "Ground Fault" switch to the "Test" position.
3. Test Set> "Reset" the Test Set, then "Test", slowly increase the "Variac" from "0" until the logic trips and the "Open" lamp lights. Observe the reading on the "Ammeter" at the moment the breaker trips and compare this to the value in Chart 2D. Return the "Variac" to "0". Repeat for other phases or pick-up settings if desired.

GROUND DELAY

1. Logic Box> Set long time delay to "MAX", set the Ground Fault Delay to the desired setting, "MIN", "INT", or "MAX".
2. Test Set> Set the "Phase Selector" switch to the desired phase, the "Logic Selector" switch to "RMS-85", and the "Ground Fault" switch to the "Test" position.
3. Test Set> "Reset" the Test Set, then "Test", hold the "Calibrate", adjust the "Variac" to a current that is 200% of the Ground Fault pick-up current. Release the "Calibrate" switch, "Stop" the Test Set if necessary.
4. Logic Box> Reset the trip indicators and the actuator if desired.
5. Test Set> "Reset", then "Test". When the logic trips, the "Open" lamp will light and the timer will quit timing. The "Trip Timer" will indicate the elapsed time. Compare this time to that of Chart 1D or the trip curves. Repeat for other phases or switch settings if desired.
6. Test Set> Return the "Variac" to "0" and "Reset" the test set.

Chart 1D – Ground Delay

Set Secondary Current
to 200% of Chart 2D.

Min .08-.17 Sec
Int .20-.32 Sec
Max .35-.50 Sec

Chart 2D – Ground Pick-up Currents

| Ground Burden | 1 | 3 | 6 | 8 | 10 | 12 |
|---------------|------|------|-------|-------|-------|-------|
| 225 | 2.22 | 6.67 | 13.33 | 17.77 | 22.22 | 26.67 |
| 600 | | 2.50 | 5.00 | 6.67 | 8.33 | 10.00 |
| 800 | | 1.87 | 3.75 | 5.00 | 6.25 | 7.50 |
| 1600 | | | 1.87 | 2.50 | 3.12 | 3.75 |
| 3000 | | | | 1.33 | 1.67 | 2.00 |
| 4000 | | | | 1.00 | 1.25 | 1.50 |

www.ElectricalPartManuals.com

Chart 1 – Time Delay Function

| | | |
|----------------------------|---|---|
| Long Time Delay | Set Secondary Current to 300% of Chart 2A | Min 8-12 Sec Int 20-30 Sec Max 60-90 Sec |
| Short Time Delay | Set Secondary Current to 150% of Chart 2B | Min .08-.17 Sec Int .20-.32 Sec Max .35-.50 Sec |
| Instantaneous Delay | Set Secondary Current to 150% of Chart 2C | No More Than .06 Sec |
| Ground Delay | Set Secondary Current to 200% of Chart 2D | Min .08-.17 Sec Int .20-.32 Sec Max .35-.50 Sec |

Chart 2A – Long Time Pick-up Currents

| | | | | | | | |
|---------|--------------|------|------|------|------|------|------|
| Amp Tap | Test Current | .4 | .55 | .7 | .8 | .9 | 1.0 |
| .5 | 2.50 | 1.00 | 1.38 | 1.75 | 2.00 | 2.25 | 2.50 |
| .75 | 3.75 | 1.50 | 2.06 | 2.63 | 3.00 | 3.38 | 3.75 |
| 1.0 | 5.00 | 2.00 | 2.75 | 3.50 | 4.00 | 4.50 | 5.00 |

Chart 2B – Short Time Pick-up Currents

| | | | | | | | |
|---------|--------------|------|-------|------|------|------|------|
| Amp Tap | Test Current | 2 | 3 | 4 | 6 | 8 | 10 |
| .5 | 2.50 | 5.0 | 7.50 | 10.0 | 15.0 | 20.0 | 25.0 |
| .75 | 3.75 | 7.50 | 11.25 | 15.0 | 22.5 | 30.0 | 37.5 |
| 1.0 | 5.00 | 10.0 | 15.0 | 20.0 | 30.0 | 40.0 | 50.0 |

Chart 2C – Instantaneous Pick-up Currents

| | | | | | | | |
|---------|--------------|------|------|------|------|------|-------|
| Amp Tap | Test Current | 4 | 5.5 | 7 | 8 | 9 | 11 |
| .5 | 2.50 | 10.0 | 13.8 | 17.5 | 20.0 | 22.5 | 27.50 |
| .75 | 3.75 | 15.0 | 20.6 | 26.3 | 30.0 | 33.8 | 41.25 |
| 1.0 | 5.00 | 20.0 | 27.5 | 35.0 | 40.0 | 45.0 | 55.00 |

Chart 2D – Ground Pick-up Currents

| | | | | | | |
|---------------|------|------|-------|-------|-------|-------|
| Ground Burden | 1 | 3 | 6 | 8 | 10 | 12 |
| 225 | 2.22 | 6.67 | 13.33 | 17.77 | 22.22 | 26.67 |
| 600 | | 2.50 | 5.00 | 6.67 | 8.33 | 10.00 |
| 800 | | 1.87 | 3.75 | 5.00 | 6.25 | 7.50 |
| 1600 | | | 1.87 | 2.50 | 3.12 | 3.75 |
| 3000 | | | | 1.33 | 1.67 | 2.00 |
| 4000 | | | | 1.00 | 1.25 | 1.50 |

*The test current values listed are secondary amperes. All pick up values may vary +/- 10%.

SAMPLE TEST CHART

LONG TIME FUNCTION: SWITCH SETTING _____ AMP TAP _____ PICKUP CURRENT _____
 DELAY SETTING _____ ELAPSED TIME A _____ B _____ C _____

SHORT TIME FUNCTION: SWITCH SETTING _____ AMP TAP _____ PICKUP CURRENT _____
 DELAY SETTING _____ ELAPSED TIME A _____ B _____ C _____ I Square T IN ___ or Out _____

INSTANTANEOUS FUNCTION: SWITCH SETTING _____ AMP TAP _____ PICKUP CURRENT _____
 ELAPSED TIME A _____ B _____ C _____

GROUND FAULT FUNCTION: PICKUP SWITCH SETTING _____ BURDEN SWITCH SETTING _____
 PICKUP CURRENT _____ DELAY SETTING _____ ELAPSED TIME A _____ B _____ C _____

www.ElectricalPartManuals.com

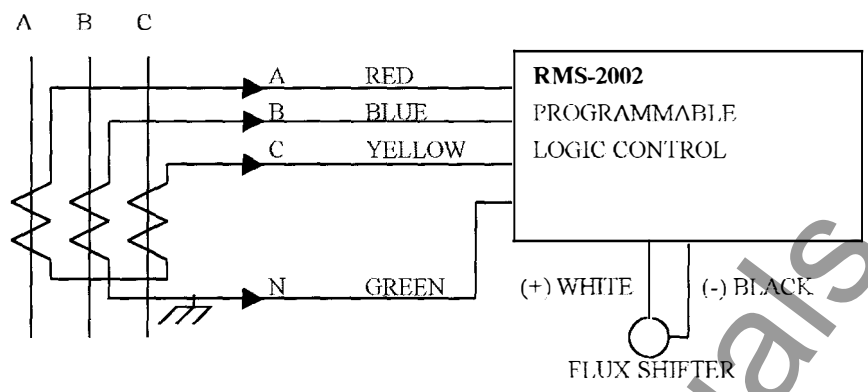

WIRING DIAGRAM FOR SYSTEMS WITHOUT
GROUND FAULT PROTECTION
DRAWING 3

TESTING GROUND FAULT SYSTEMS

Connect the green wire from the wiring harness (COMMON) to the CT's while testing all trip functions, except the ground fault. To test the ground fault function, disconnect the green wire and connect the orange wire and perform the test.

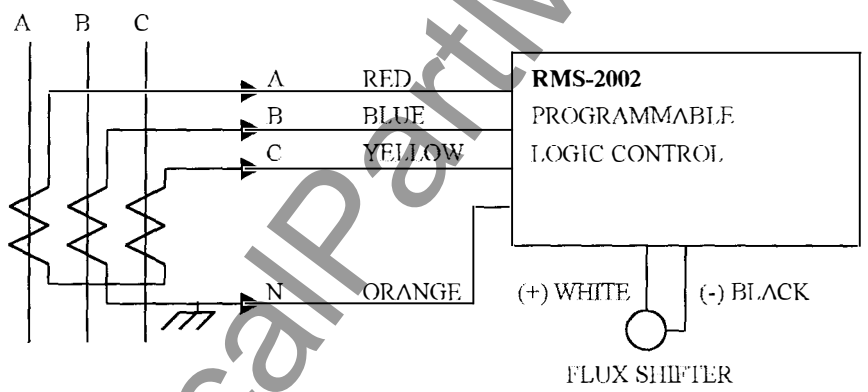

WIRING DIAGRAM FOR 3-WIRE SYSTEMS
WITH GROUND FAULT PROTECTION
DRAWING 4

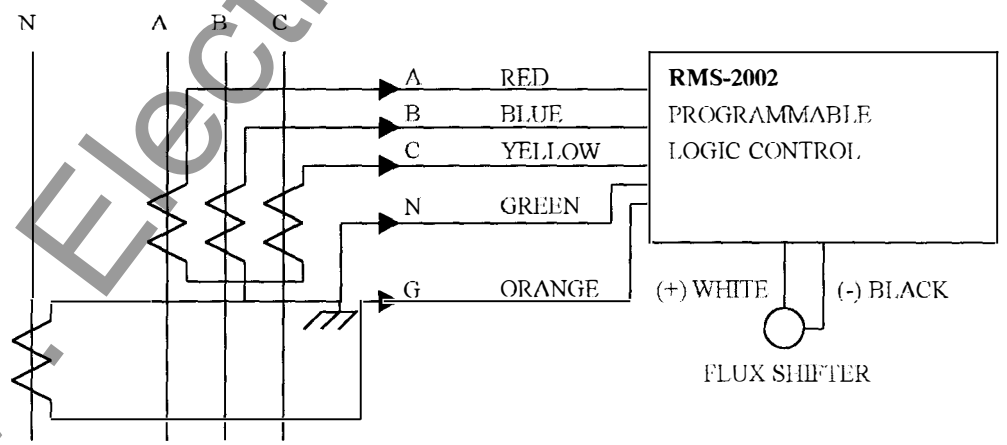

WIRING DIAGRAM FOR 4-WIRE SYSTEMS
WITH GROUND FAULT PROTECTION
DRAWING 5

www.ElectricalPartManuals.com

www.ElectricalPartManuals.com

RMS-2002

OEM REPLACEMENT TRIP UNIT

THE **RMS-2002** IS SPECIFICALLY DESIGNED TO ALLOW THE USER THE FLEXIBILITY OF **UTILIZING THE EXISTING CURRENT SENSORS AND ACTUATORS** WHEN AVAILABLE. THE OEM REPLACEMENT TRIP UNIT IS THE STANDARD **RMS-2002**, BUT IS BUILT TO WORK WITH THE SPECIFIC RATIO OF THE CURRENT SENSORS THAT HAVE ALREADY BEEN INSTALLED ON THE BREAKER.

MODELS AVAILABLE

| | |
|--------------------|--------------|
| RMS-2002-1A | 1 AMP PICKUP |
| RMS-2002-2A | 2 AMP PICKUP |
| RMS-2002-5A | 5 AMP PICKUP |

THE **RMS-2002-X**'A CAN BE CALIBRATED TO MEET OEM CURRENT TRANSFORMER OUTPUTS, NOT LESS THAN 1 AMP.

THE **RMS-2002** CAN REPLACE ALL THE TRIP UNITS LISTED BELOW AND MORE. If you do not see your specific unit listed, please contact sales:

Toll-Free (877) 382-5864 or (800) 382-5864

ABB-BBC POWERSHIELD SS1-SS6

SIEMENS-ALLIS STATIC TRIP 1 and 2

SIEMENS-ALLIS LIMIT TRIP

WESTINGHOUSE ITEKTOR-RK-SPCB

WESTINGHOUSE AMPTECTOR IA and IIA

WESTINGHOUSE DIGI-TRIP

GENERAL ELECTRIC ECS-SST-Versa Trip

GENERAL ELECTRIC RMS9 MicroVersa Trip

www.ElectricalPartManuals.com

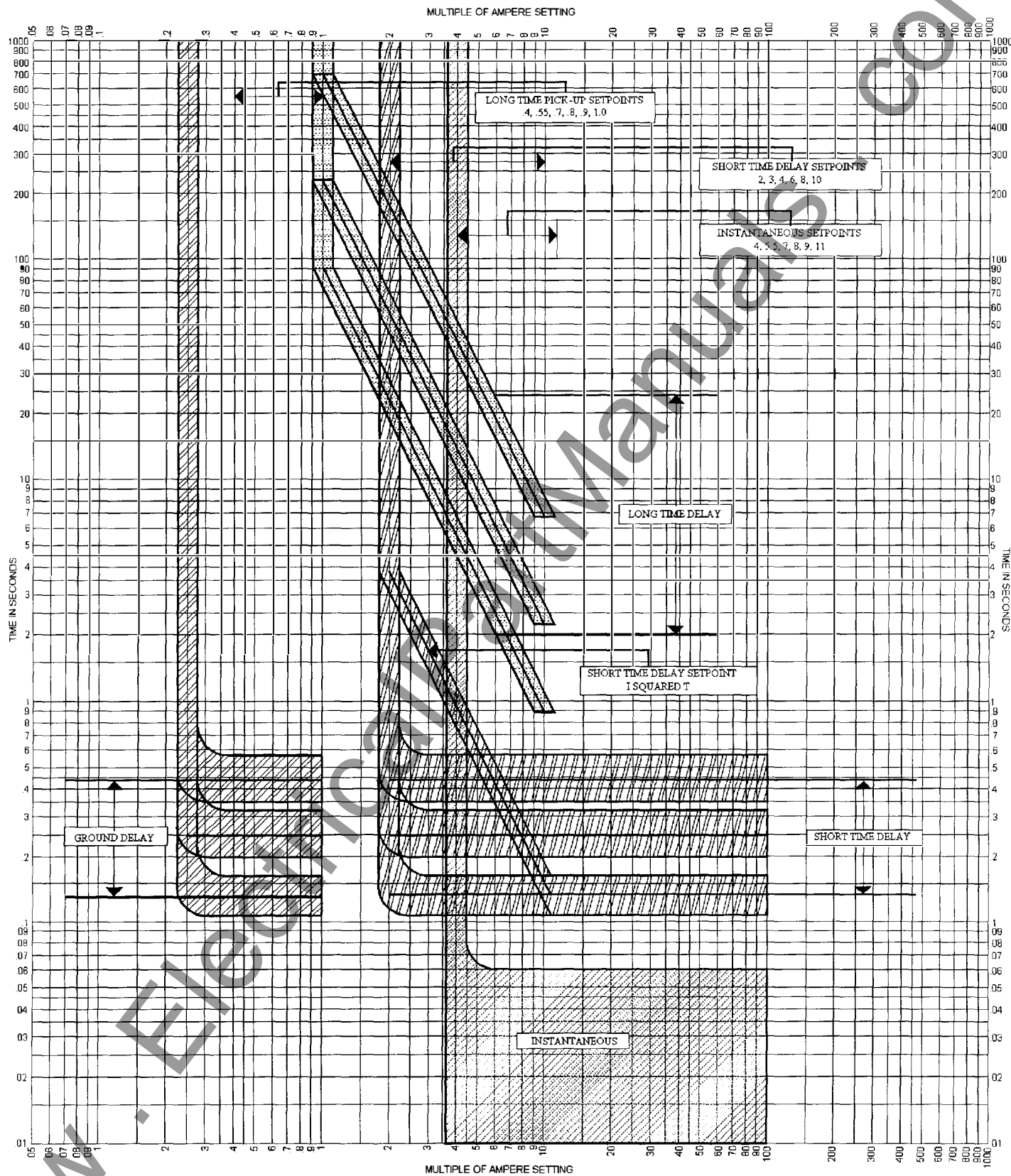

RMS-2002 PROGRAMMABLE LOGIC CONTROL Rev.01
 TIME-CURRENT CHARACTERISTIC CURVES
 FOR SURE TRIP, INC. DATED January 1, 2003
 STANDARD DEVIATION FOR AMPERE SETTING IS +/- 10%

www.ElectricalPartManuals.com

1 AMP SYSTEM CHART

Chart 3 – Time Delay Function

| | | |
|---------------------|---|---|
| Long Time Delay | Set Secondary Current to 300% of Chart 3A | Min 8-12 Sec Int 20-30 Sec Max 60-90 Sec |
| Short Time Delay | Set Secondary Current to 150% of Chart 3B | Min .08-.17 Sec Int .20-.32 Sec Max .35-.50 Sec |
| Instantaneous Delay | Set Secondary Current to 150% of Chart 3C | No More Than .06 Sec |
| Ground Delay | Set Secondary Current to 200% of Chart 3D | Min .08-.17 Sec Int .20-.32 Sec Max .35-.50 Sec |

Chart 3A – Long Time Pick-up Currents

| | | | | | | |
|--------------|------|------|------|------|------|------|
| Test Current | .4 | .55 | .7 | .8 | .9 | 1.0 |
| 1.00 | .400 | .550 | .700 | .800 | .900 | 1.00 |

Chart 3B –Short Time Pick-up Currents

| | | | | | | |
|--------------|------|------|------|------|------|-------|
| Test Current | 2 | 3 | 4 | 6 | 8 | 10 |
| 1.00 | 2.00 | 3.00 | 4.00 | 6.00 | 8.00 | 10.00 |

Chart 3C – Instantaneous Pick-up Currents

| | | | | | | |
|--------------|------|------|------|------|------|-------|
| Test Current | 4 | 5.5 | 7 | 8 | 9 | 11 |
| 1.00 | 4.00 | 5.50 | 7.00 | 8.00 | 9.00 | 11.00 |

Chart 3D – Ground Pick-up Currents

| | | | | | | |
|---------------|------|-------|-------|-------|-------|-------|
| Ground Burden | 1 | 3 | 6 | 8 | 10 | 12 |
| 225 | .444 | 1.334 | 2.666 | 3.554 | 4.444 | 5.334 |
| 600 | | .500 | 1.000 | 1.334 | 1.666 | 2.000 |
| 800 | | .374 | .750 | 1.000 | 1.125 | 1.500 |
| 1600 | | | .374 | .500 | .624 | .750 |
| 3000 | | | | .267 | .333 | .400 |
| 4000 | | | | .200 | .250 | .300 |

The test current values listed are secondary amperes. All pick up values may vary +/- 10%.

SAMPLE TEST CHART

LONG TIME FUNCTION: SWITCH SETTING _____ PICKUP CURRENT _____
 DELAY SETTING _____ ELAPSED TIME A _____ B _____ C _____

SHORT TIME FUNCTION: SWITCH SETTING _____ PICKUP CURRENT _____
 DELAY SETTING _____ ELAPSED TIME A _____ B _____ C _____ I Square T IN ___ or Out ___

INSTANTANEOUS FUNCTION: SWITCH SETTING _____ PICKUP CURRENT _____
 ELAPSED TIME A _____ B _____ C _____

GROUND FAULT FUNCTION: PICKUP SWITCH SETTING _____ BURDEN SWITCH SETTING _____
 PICKUP CURRENT _____ DELAY SETTING _____ ELAPSED TIME A _____ B _____ C _____

www.ElectricalPartManuals.com

SURE TRIP Inc.

US FUNDS

February 2, 2003

COMPLETE KITS : Include Logic, Actuator, Sensors, Copper (if specified) and mounting hardware

ORDERING : If Ground is required change the I to G and add \$50.00

AMP TAP SWITCH Option add \$80.00

FUNCTION ACTIVE SELECTOR Option add \$80.0

40 Year Aging Upgrade add \$100.00

THE RMS 2002 LOGIC is a direct replacement for AMPTECTOR, DIGI TRIP and ITEKTOR

| 1 YEAR WARRANTY | | | FREIGHT COLLECT | MULTIPLIER | TERMS NET 20 days | | |
|-----------------|--------------|-----|-----------------|------------|-------------------|----------|-----------|
| COMPANY NAME | | | LOCATION | 0.5 | LIST YOUR COST | | |
| MAKE | TYPE | AMP | STYLE | PART # | COPPER | LSI | LSI |
| WEST | DS LOGIC KIT | ALL | ALL | STI-900 | | \$850.00 | \$ 425.00 |
| CH | DS LOGIC KIT | ALL | ALL | STI-900 | | \$850.00 | \$ 425.00 |

| | | | | | | | |
|--|-------------|--|--|-----------|--|----------|-----------|
| | 5 AMP LOGIC | | | ST-LSI-5A | | \$780.00 | \$ 390.00 |
| | 1 AMP LOGIC | | | ST-LSI-1A | | \$980.00 | \$ 490.00 |
| | 2 AMP LOGIC | | | ST-LSI-2A | | \$980.00 | \$ 490.00 |

| | | | | | | | |
|----|----------|------|-------------|---------|----------|-------|-----------|
| AC | LA-25 | 600 | DO/MO-EO | STI-240 | INCLUDED | ##### | \$ 650.00 |
| AC | LA600 | 600 | All | STI-245 | N/A | ##### | \$ 650.00 |
| AC | LA-25A | 600 | DO/MO-EO | STI-250 | INCLUDED | ##### | \$ 650.00 |
| AC | LA600A/B | 600 | All | STI-260 | N/A | ##### | \$ 650.00 |
| AC | LA600AF | 600 | All (fused) | STI-265 | N/A | ##### | \$ 650.00 |
| AC | LA-50 | 1600 | DO/MO-EO | STI-490 | N/A | ##### | \$ 700.00 |
| AC | LA-50A | 1600 | DO/MO-EO | STI-500 | N/A | ##### | \$ 700.00 |
| AC | LA1600 | 1600 | DO/MO | STI-510 | N/A | ##### | \$ 700.00 |

| | | | | | | | |
|-----|--------------|------|-----------|---------|-----------|-------|-----------|
| FPE | 100HF-1 | 600 | DO/MO-EO | STI-080 | INCLUDED | ##### | \$ 710.00 |
| FPE | 25,50H-1 | 600 | DO/MO-EO | STI-100 | N/A | ##### | \$ 710.00 |
| FPE | 25,50H-2 | 600 | DO/MO-EO | STI-110 | N/A | ##### | \$ 710.00 |
| FPE | 25H | 600 | DO/MO | STI-120 | INCLUDED | ##### | \$ 710.00 |
| FPE | 30H-3 | 600 | DO/MO/EO | STI-140 | N/A | ##### | \$ 710.00 |
| FPE | 100HF-1 | 1600 | DO/MO-EO | STI-320 | N/A | ##### | \$ 760.00 |
| FPE | 25/50/65H2&3 | 1600 | DO/MO-EO | STI-330 | N/A | ##### | \$ 760.00 |
| FPE | 25,50H-1 | 1600 | ALL | STI-340 | N/A | ##### | \$ 760.00 |
| FPE | 25H | 1600 | FXD/MO-EO | STI-350 | N/A | ##### | \$ 760.00 |
| FPE | 50H | 1600 | DO/MO | STI-370 | N/A | ##### | \$ 760.00 |
| FPE | 50H-2 | 1600 | FXD/MO | STI-380 | N/A | ##### | \$ 760.00 |
| FPE | 25/50/65H-2 | 2000 | DO/MO-EO | STI-520 | NOT REQ'D | ##### | \$ 785.00 |
| FPE | 50/75/100H2 | 3000 | DO/MO-EO | STI-590 | NOT REQ'D | ##### | \$ 785.00 |
| FPE | 50,75H-1 | 3000 | DO/MO-EO | STI-600 | NOT REQ'D | ##### | \$ 785.00 |
| FPE | 75H | 3000 | DO/MO | STI-620 | NOT REQ'D | ##### | \$ 785.00 |
| FPE | 75,100H-1 | 4000 | DO/MO/EO | STI-780 | NOT REQ'D | QUOTE | |
| FPE | 75-100H2 | 4000 | DO/MO/EO | STI-781 | NOT REQ'D | QUOTE | |

| | | | | | | | |
|----|------------|-----|-----------|---------|----------|-------|-----------|
| GE | AK1-15 | 225 | FXD-DO/MO | STI-010 | INCLUDED | ##### | \$ 650.00 |
| GE | AK1-15 | 225 | FXD-DO/EO | STI-011 | INCLUDED | ##### | \$ 650.00 |
| GE | AK-2,2A-15 | 225 | FXD-DO/MO | STI-020 | INCLUDED | ##### | \$ 650.00 |
| GE | AK-2,2A-15 | 225 | FXD-DO/EO | STI-021 | INCLUDED | ##### | \$ 650.00 |
| GE | AK1-25 | 600 | DO/MO | STI-024 | INCLUDED | ##### | \$ 650.00 |

www.ElectricalPartManuals.com

| | | | | | | | |
|-------------|-------------|------|--------------|---------|-----------|-------|-----------|
| GE | AK1-25 | 600 | DO/EO | STI-025 | INCLUDED | ##### | \$ 650.00 |
| GE | AK1-25 | 600 | Bucket Style | STI-026 | INCLUDED | ##### | \$ 650.00 |
| GE | AK-2-25 | 600 | DO/MO | STI-150 | INCLUDED | ##### | \$ 650.00 |
| GE | AK-2-25 | 600 | DO/EO | STI-151 | INCLUDED | ##### | \$ 650.00 |
| GE | AKU-2/3-25 | 600 | DO/MO | STI-160 | INCLUDED | ##### | \$ 650.00 |
| GE | AK-1-50 | 1600 | ALL | STI-400 | INCLUDED | ##### | \$ 700.00 |
| GE | AK-2-50 | 1600 | ALL | STI-401 | INCLUDED | ##### | \$ 700.00 |
| GE | AK-3-50 | 1600 | ALL | STI-402 | INCLUDED | ##### | \$ 700.00 |
| GE | AK-1,2,3-75 | 3000 | DO/MO-EO | STI-630 | NOT REQ'D | ##### | \$ 725.00 |
| GE | AK-1,2,3-75 | 3000 | FXD/MO-EO | STI-632 | NOT REQ'D | ##### | \$ 725.00 |
| GE | AK-3A-75 | 3000 | DO/MO | STI-640 | NOT REQ'D | ##### | \$ 725.00 |
| GE | AK-1,2-100 | 4000 | DO/MO-EO | STI-790 | NOT REQ'D | ##### | \$ 750.00 |
| ITE | | | | | | | |
| ITE | KA | 225 | FXD-DO/MO | STI-070 | INCLUDED | ##### | \$ 650.00 |
| ITE | K225 | 225 | DO/MO/EO | STI-200 | INCLUDED | ##### | \$ 650.00 |
| ITE | KB-Metal | 600 | ALL | STI-090 | NOT REQ'D | ##### | \$ 650.00 |
| ITE | KB-Slate | 600 | All | STI-092 | NOT REQ'D | ##### | \$ 650.00 |
| ITE | K600 | 600 | DO-MO-EO | STI-211 | INCLUDED | ##### | \$ 650.00 |
| ITE | KDON600 | 600 | DO/MO/EO | STI-230 | INCLUDED | ##### | \$ 650.00 |
| ITE | K800 | 800 | | STI-270 | N/A | ##### | \$ 700.00 |
| ITE | KC,KC3 | 800 | ALL | STI-305 | N/A | ##### | \$ 700.00 |
| ITE | KC,KC3 | 1600 | ALL | STI-310 | N/A | ##### | \$ 700.00 |
| ITE | K1600 RED | 1600 | ALL | STI-470 | INCLUDED | ##### | \$ 700.00 |
| ITE | K1600 BLK | 1600 | ALL | STI-480 | INCLUDED | ##### | \$ 700.00 |
| ITE | K2000 | 2000 | ALL | STI-580 | NOT REQ'D | ##### | \$ 725.00 |
| ITE | KD | 3000 | DO/MO-EO | STI-720 | NOT REQ'D | ##### | \$ 725.00 |
| ITE | KD | 3000 | FXD/MO-EO | STI-722 | NOT REQ'D | ##### | \$ 725.00 |
| ITE | K3000 | 3000 | DO/MO/EO | STI-740 | NOT REQ'D | ##### | \$ 725.00 |
| ITE | K4000 | 4000 | | | | QUOTE | |
| WEST | | | | | | | |
| WEST | DB-15 | 225 | DO/MO-EO | STI-030 | N/A | ##### | \$ 650.00 |
| WEST | DB-15 | 225 | FXD/EO | STI-032 | N/A | ##### | \$ 650.00 |
| WEST | DB,DBL-25 | 600 | DO/MO-EO | STI-170 | INCLUDED | ##### | \$ 650.00 |
| WEST | DB,DBL-25 | 600 | FXD/MO-EO | STI-172 | INCLUDED | ##### | \$ 650.00 |
| WEST | DB-50 | 1600 | DO/MO-EO | STI-430 | INCLUDED | ##### | \$ 700.00 |
| WEST | DB-50 | 1600 | FXD/MO-EO | STI-432 | INCLUDED | ##### | \$ 700.00 |
| WEST | DBL-50 | 1600 | ALL | STI-440 | INCLUDED | ##### | \$ 700.00 |
| WEST | DB-75 | 3000 | DO/MO-EO | STI-700 | NOT REQ'D | ##### | \$ 725.00 |
| WEST | DB-75 | 3000 | FXD/MO-EO | STI-702 | NOT REQ'D | ##### | \$ 725.00 |
| WEST | DB-75 Cast | 3000 | DO/MO-EO | STI-705 | NOT REQ'D | ##### | \$ 725.00 |
| WEST | DB-100 | 4000 | DO/MO-EO | STI-820 | NOT REQ'D | ##### | \$ 750.00 |
| WEST | DB-100 | 4000 | FXD/MO-EO | STI-830 | NOT REQ'D | ##### | \$ 750.00 |

www.ElectricalPartManuals.com