

POWER-ZONE® III

Low Voltage Metal-Enclosed Drawout Switchgear

CONTENTS

Description	Class	Pages
General Description.....	6035.....	2
Enclosures.....	6035.....	3
Circuit Breaker Trip Unit Descriptions.....	6035.....	4-5
Circuit Breaker Description - DS/DSL.....	6035.....	6-7
Options.....	6035.....	8
Ratings - Layout - Dimensions.....	6035.....	9-14
Suggested Specifications.....	6035.....	15-16



SQUARE D
 GROUPE SCHNEIDER

POWER-ZONE® III

Low Voltage Metal-Enclosed Drawout Switchgear

General Description

Ratings:

Main Bus – 5000 ampere maximum

120/208 to 600 Volts, AC, 1Ø 3W, or 3Ø 4W.

Available Breakers:

DS, DSL-206, DS-206H, DS-206E	800A Frame
DS, DSL-416, DS-416H	1600A Frame
DS-420	2000A Frame
DS, DSL-632	3200A Frame
DS, DSL-840	4000A Frame
DS-850 (Forced air cooled)	5000A Frame (Not UL Listed)

Applicable Standards:

Circuit Breakers:

NEMASG3

ANSI C37.13

ANSI C37.16

UL 1066 (Optional)

(DS-850 Not Available)

Structures:

NEMASG5

ANSI C37.20.1

ANSI C37.51

UL1558 (Optional)

(DS-850 Not Available)

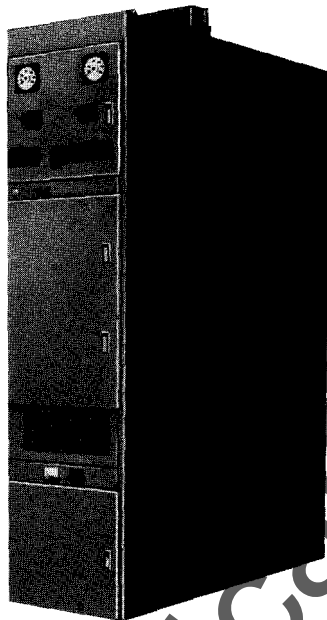

Features:

- Totally enclosed, dead front, free standing
- Front and rear alignment
- Covers installed with single tool, slotted hex-head screws
- Removable top plate, rear panel and side panel
- Corrosion-resistant finish
- Single or multiple mains
 1. Individually mounted drawout circuit breakers
 2. ANSI-rated low voltage power circuit breaker
 3. Front accessible, rear connected
 4. 100% rated, two-step stored energy circuit breakers
 5. 800-5000 ampere frame
- Feeders
 1. Individually mounted drawout circuit breakers
 2. ANSI-rated low voltage power circuit breaker
 3. Front accessible, rear connected
 4. 100% rated, two-step stored energy circuit breakers
 5. 800-4000 ampere frame
- Structures compartmentalized and barriered per ANSI C37.20.1

- Provision for future extension
- Increased mounting space within main and feeder sections
- Bolted copper bus provided as standard up to 5000 amperes max.
- Dual steel front barriers – the compartment door and the circuit breaker front panel
- Ground bus with lugs
- Shipment as separate switchgear section or up to a maximum of four sections
- Removable lifting straps
- Interrupting rating* – 30kA to 85kA at 480Vac *(200,000 AIC when fused)

General

POWER-ZONE® III Switchgear is premium distribution equipment designed to offer the user many operational security features: minimum down-time, system selectivity, ease of maintenance, and large functional capacity.

The types DS (not fusible) and DSL (fused) low voltage power circuit breakers are the primary components of POWER-ZONE III switchgear. These circuit breakers employ a solid state tripping device offering the latest in circuit protection.

Functional and operational advantages are:

Operational Security Features – Compartmentalized and barriered construction per ANSI C37.20.1.

Dual steel front barriers: one as the full cell door covering the circuit breaker manual operation controls and one as the front of the circuit breaker element covering the circuit breaker mechanism.

Minimum Down-Time – Drawout construction allows quick and simple replacement of breaker elements. If an emergency occurs, breakers may be removed from low priority circuits and re-installed to serve high priority circuits.

Ease of Maintenance – Circuit breakers are simple to inspect, adjust, and replace. They can be withdrawn from their compartments for convenient maintenance or inspection.

Functional Capacity – Large frame sizes and high withstand ratings make the DS and DSL low voltage power circuit breakers ideal for application on today's high capacity distribution systems.

System Selectivity – The solid state trip devices provided on each DS and DSL low voltage power breaker are field adjustable, enabling the user to attain optimum selectivity and coordination.

UL Listing – POWER-ZONE III switchgear can be designed and engineered to comply with UL requirements. DS and DSL power circuit breakers (except the DS-850) are optionally available with a UL listing. Where UL coverage exists for all component materials, parts and devices in a switchgear section, a UL label can be affixed.

For Additional Information – POWER-ZONE III Switchgear is described in general but brief terms here. More detailed and comprehensive data is also available from your local Square D sales office.



POWER-ZONE® III Low Voltage Metal-Enclosed Drawout Switchgear Enclosures

Indoor Enclosures

Compartmentalized Construction:

POWER-ZONE III Switchgear offers high reliability through compartmentalized construction.

The three compartments are:

1. Circuit breaker or instrument compartment.
2. Bus compartment.
3. Cable compartment.

Isolation between the bus and cable compartments and/or between adjacent bays is available through optional vertical barriers.

NOTE: If incoming conductors are considered to be "Service Conductors," then barriers per N.E.C. Article 384-3 must be specified.

The optional neutral bus is located on the innermost portion of the cable compartment, thereby allowing easy access to line and load connectors.

Outdoor Enclosures

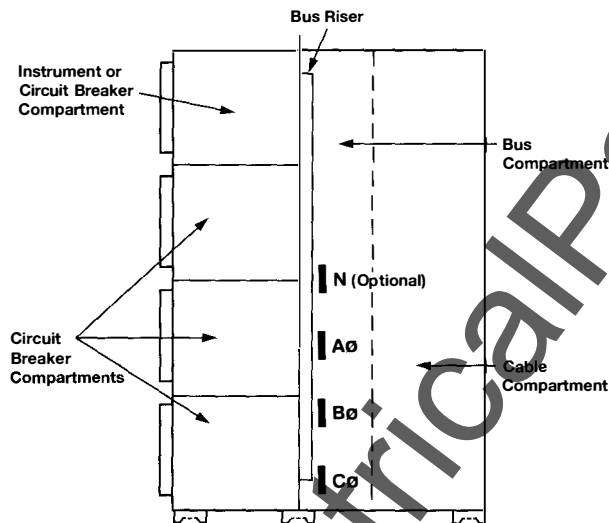

Side View Illustration of Typical Switchgear

POWER-ZONE III Switchgear is available in a walk-in POWER ZONE Center enclosure for outdoor installation. Also a non-walk-in enclosure is available. Both enclosures are NEMA Type 3R as standard.

Non-walk-in enclosures are equipped with:

- Strip heaters in breaker cells and bus compartment
- Front and rear lockable equipment doors with three point latching and filtered openings for ventilation
- Removable gasketed steel cover plates over conduit entrance
- One piece construction for ease of installation

Options Available:

- Mobile floor crane to handle breaker
- Top entry/exit for incoming and outgoing cables
- Capability for future expansion
- Interior and exterior lighting and convenience outlets



POWER ZONE® Center

POWER ZONE Center

The walk-in POWER ZONE Center is equipped with the following standard features:

- Front aisle with steel entrance door equipped with panic hardware
- Lockable rear equipment doors hinged with 3-point latching and filtered openings for air intake
- Interior fluorescent lighting
- Three-way light switch and convenience outlets located near the entrance door
- Strip heaters in breaker cells and bus compartment
- Overhead breaker lifting device
- Removable gasketed steel cover plates over conduit entrance
- One piece construction for ease of installation

Options Available:

- Extended aisle for additional work space
- Exhaust fan ventilation/Inside temperature control
- Exterior lighting
- Inside emergency lighting
- Wall mounted AC distribution panel
- Top entry/exit for incoming and outgoing cables
- Capability for future expansion
- Modified NEMA Types:
 - Types 4 and 4X
 - Types 7 and 9 for use in hazardous areas

POWER-ZONE® III Low Voltage Metal-Enclosed Drawout Switchgear Circuit Breaker Trip Unit Description

POWER-ZONE III Switchgear utilizes the Type DS Low-Voltage Power Circuit Breaker. This circuit breaker is available in six basic frame sizes which are tabulated along with their respective interrupting capacities on page 9. **The breaker overcurrent protection consists of a solid-state trip device that requires no external power source.** The complete tripping system has three basic components; the molded sensors, the trip device (with rating plug) and the trip actuator.

Each pole of the circuit breaker is equipped with a molded sensor located on the bottom rear main disconnect contacts. These sensors produce an output proportional to the load current, that is fed into the trip device which has the intelligence and energy to operate the trip actuator when required. The trip actuator receives the tripping pulse from the microprocessor based trip unit and produces a mechanical force to trip the circuit breaker.

Type DS circuit breakers are equipped with the controls shown below. All circuit breakers are fully stored energy devices with a two-step operating mechanism.

A spring charging handle charges the mechanism and the breaker contacts are closed by pushing the "Push To Close" button, which is conveniently located on the face of the breaker.

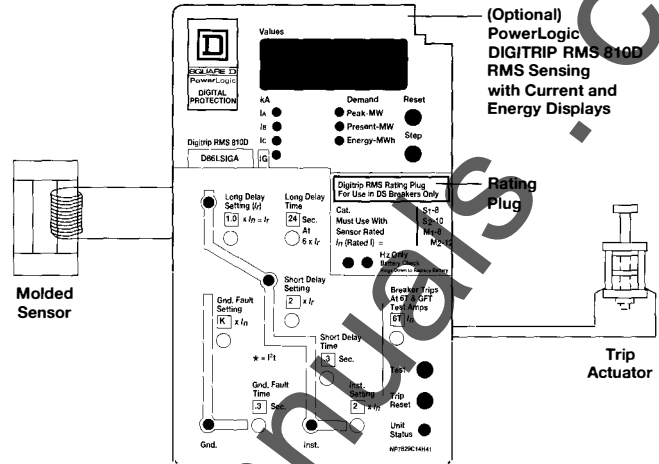

Schematic illustration of tripping system

Electrically operated breakers have a motor to charge the stored energy mechanism, electric close feature and electric open feature.

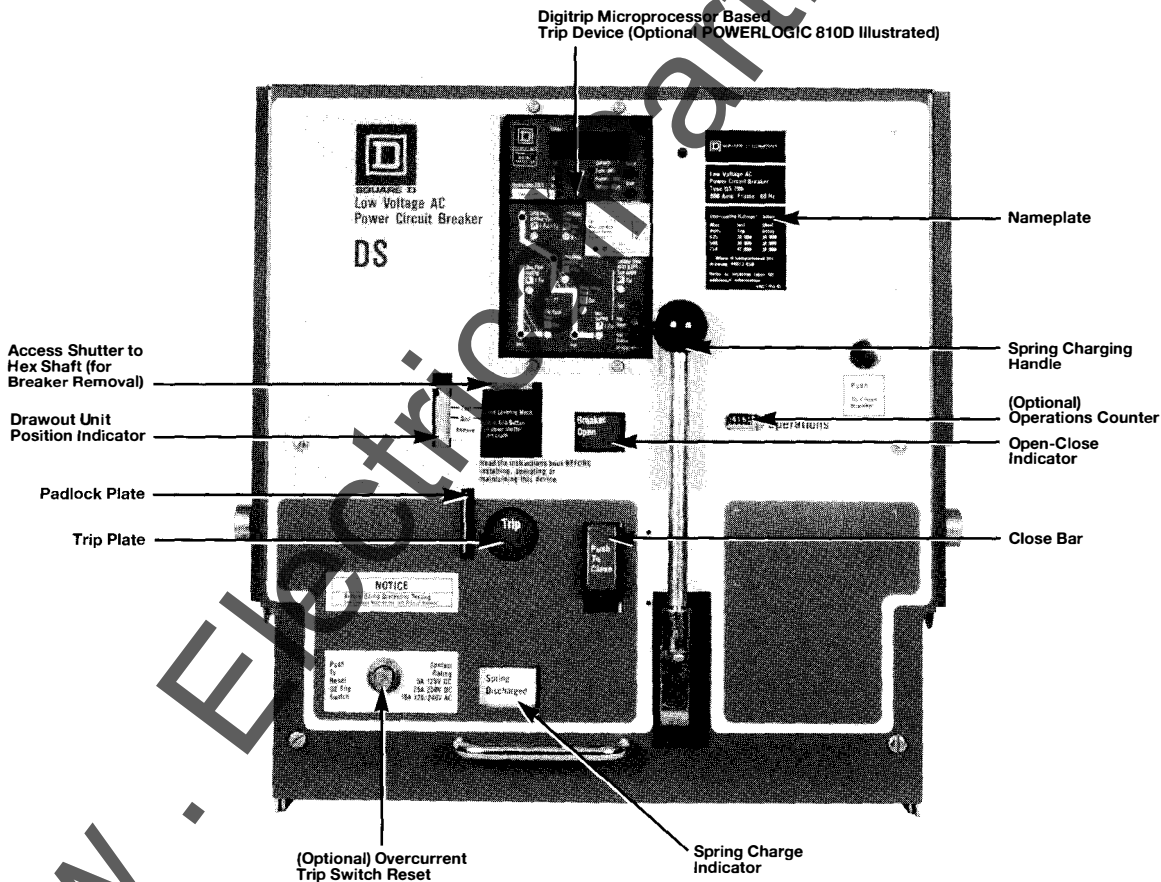

DS Circuit Breakers supplied by Square D Company are fully warranted and backed by Square D, its sales and technical service personnel.



POWER-ZONE® III Low Voltage Metal-Enclosed Drawout Switchgear Circuit Breaker Trip Unit Description

Digitrip® RMS 510 (Standard trip unit)

Standard trip features include:

- RMS sensing
- Integral trip unit testing
- Unit status indicator
- Adjustable long delay and ampere setting
- Local mode of trip indicators
- Rating plug

Optional features include:

- Adjustable short time delay and pickup
- Adjustable ground fault delay and pickup
- Selectable I_t on short time and ground fault
- Zone selective interlocking (only with other DS breakers equipped with Digitrip trip units.)

Digitrip RMS 610 and the POWERLOGIC Digitrip RMS 810D are optional.

Digitrip RMS 610 (Optional)

Standard trip features include:

- All features of the RMS 510
- Local four-digit alphanumeric display
 - Amperes
 - Mode of trip
 - Service trip messages
- Local hi-load indication
- Remote signal contacts for hi-load and mode of trip (via the auxiliary trip relay-ATR)

POWERLOGIC Digitrip RMS 810D (Optional)

Standard trip features include:

- All features of the RMS 510 and RMS 610
- Energy and power monitoring
 - Peak demand^①
 - Present demand^①
 - Energy consumption^①
- Direct communications link to the Square D POWERLOGIC Power Monitoring and Control System
 - Amperes
 - Energy and demand information
 - Remote breaker operation
 - Service and trip messages

POWER-ZONE III Low Voltage Drawout Switchgear is available with the Square D POWERLOGIC metering, data acquisition, and control system.

Basic circuit information, such as amperes and energy consumption, as well as breaker remote operation, can be accomplished using the POWERLOGIC Digitrip 810D trip unit. For more sophisticated metering, data acquisition, and control,

POWERLOGIC Circuit Monitors should also be considered. POWERLOGIC Circuit Monitors replace a variety of discrete meters, transducers and other components and perform these functions:

- Meters Amperes, Volts
- Watts
- Vars
- kVA
- Power Factor
- Frequency
- Thermal Demand
- Watthour with Demand
- Varhours
- Records data

Industry standard RS-485 data communications allow the POWERLOGIC system to replace multiple transducers, analog wires and analog-to-digital conversion equipment. Extensive information can be transmitted over a single communications cable to a POWERLOGIC System Display, a personal computer, SY/MAX Programmable Controller, or other host system.

In addition to its metering capabilities, the POWERLOGIC system is available with optional status inputs and relay outputs for monitoring discrete contacts and remote control of devices via the data communications channel. A POWERLOGIC Circuit Monitor, equipped with a "waveform capture" function, offers a new class of circuit information, not previously available using discrete devices. Comprehensive profiles of current and voltage waveforms, suitable for harmonics studies and other power quality analyses, are reported on user-command.

For additional information on POWERLOGIC Systems consult your local Square D sales office.

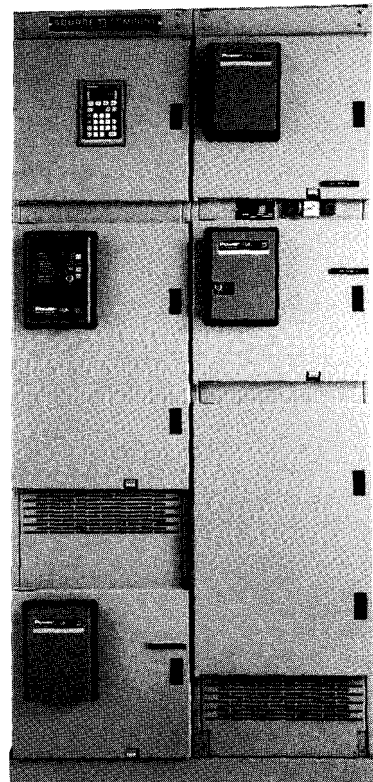

POWER-ZONE® III LV Drawout Switchgear with POWERLOGIC Circuit Monitors and System Display (upper left)

^① True energy and demand are calculated in conjunction with a built-in potential transformer module.



POWER-ZONE® III Low Voltage Metal-Enclosed Drawout Switchgear Circuit Breaker Description — DS/DSL

The main disconnecting contacts located on the rear of the breaker are spring loaded and self-aligning to ensure positive electrical contact when the breaker is in the connected position. These contacts are designed so the pressure at the point of contact on the stationary stud becomes greater under short circuit conditions.

The secondary disconnecting contacts are also located on the rear of the circuit breaker element and are used for connecting the accessories to the control power source or other control circuits. These contacts are in the “make” position when the element is in the “Connected” and “Test” positions.

Breakers of like frame sizes and interrupting ratings are interchangeable as standard.

POWER-ZONE III Switchgear is also available with fused power circuit breakers. Fused circuit breakers have a short circuit interrupting fusing of 200,000 amperes symmetrical. The breaker element including the microprocessor based tripping system is identical to that of a non-fusible circuit breaker

except for the addition of the fuses and other circuitry necessary for the proper functioning of the fuse protection system.

Current limiting fuses are available on the 800A, 1600A, 3200A, and 4000A frame power circuit breakers. The current limiting fuses are mounted integrally on the rear of the circuit breaker element for the 800A and 1600A frame sizes and are mounted on a separate drawout truck for the 3200A and 4000A frame sizes. When fuses are mounted on a separate fuse truck the drawout mechanisms are mechanically key interlocked with the circuit breaker element.

All versions of the fused circuit breaker are equipped with blown fuse indication and anti-single phasing as standard.

Fused breakers of like frame sizes are interchangeable as standard.

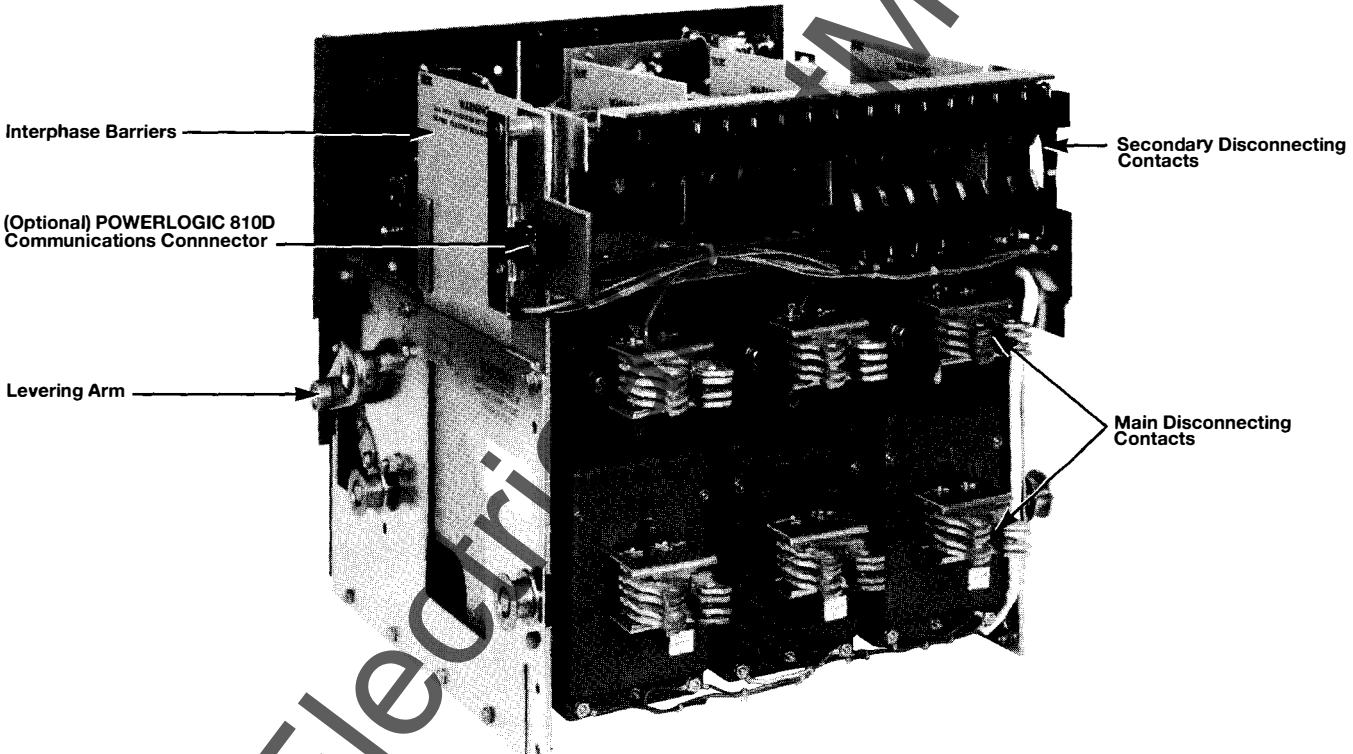

Rear View of DS-206 Circuit Breaker Element

POWER-ZONE® III
Low Voltage Metal-Enclosed Drawout Switchgear
Circuit Breaker Description — DS/DSL

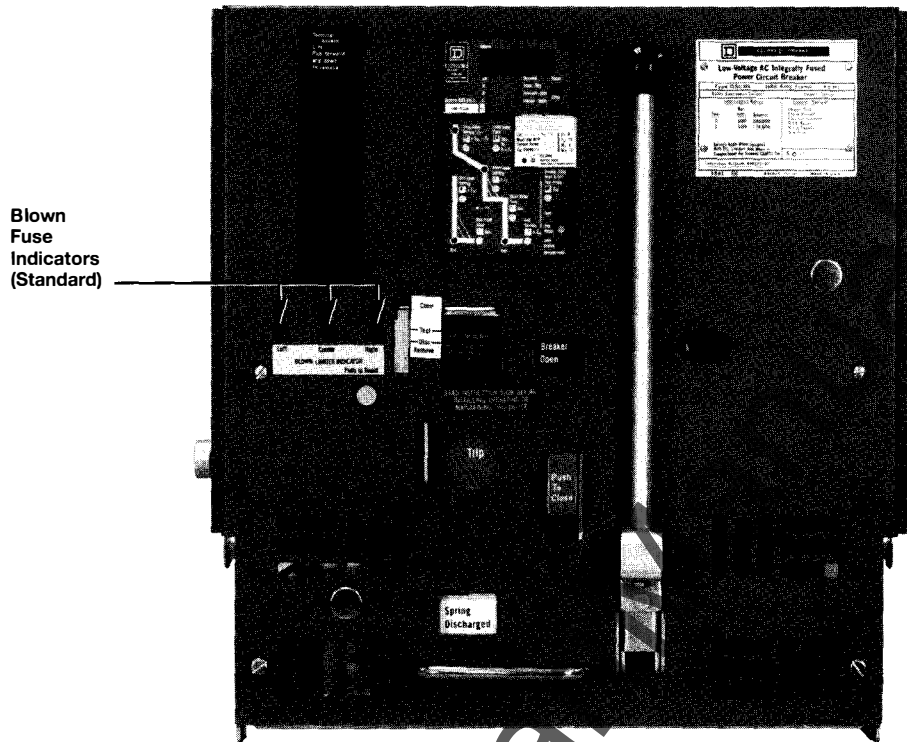

Front View of DSL-206 Circuit Breaker

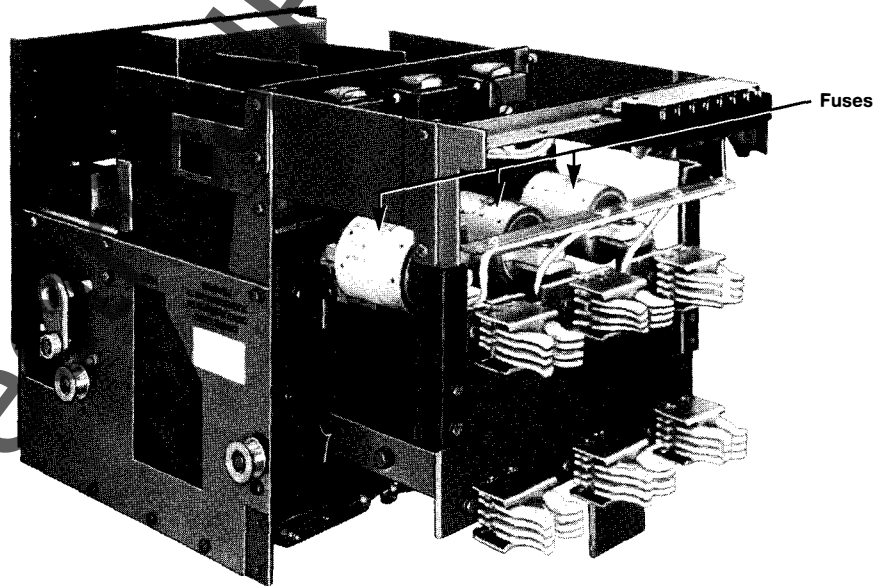

Rear View of DSL-206 Circuit Breaker Equipped With Integral Current Limiting Fuses



POWER-ZONE® III

Low Voltage Metal-Enclosed Drawout Switchgear Options

Test and Maintenance Option

All type DS and DSL power circuit breakers equipped with microprocessor based trip devices have a built-in test feature, as well as plug-in type test facilities which enable the user to test all tripping functions.

The DS circuit breaker test stand provides mobility for moving circuit breakers to the test area, a convenient height for visual inspection of breakers, contacts for testing all secondary control functions, a test equipment shelf for mounting the test kit, and power contacts for high current testing and calibration.

A rail-mounted traveling type breaker lifting device is optionally available with indoor type switchgear. It is supplied as standard with outdoor walk-in enclosures.

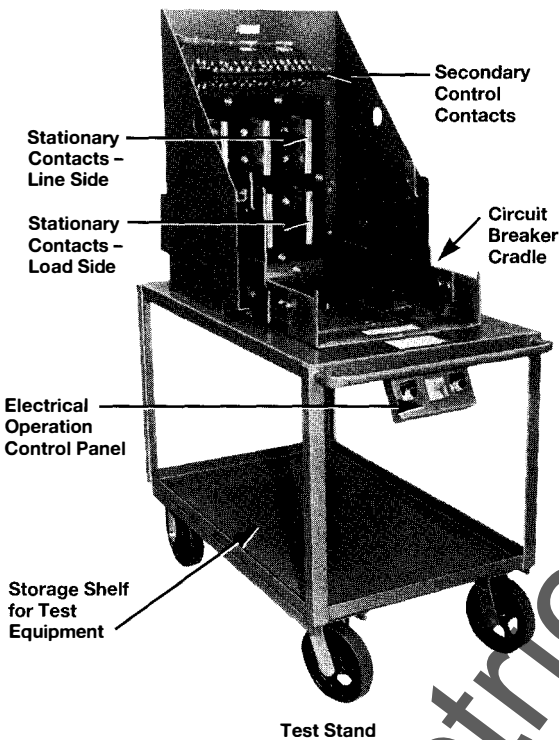

Miscellaneous Breaker Options and Accessories

- Digitrip 610 and POWERLOGIC 810D Trip Units
- Shunt trip for manually operated breakers
- Auxiliary switch with four 10 ampere contacts. A maximum of three auxiliary switches can be supplied per breaker.
- Cell switch with 12 Form "C" contacts. Operates when breaker is drawn from connected to test position.
- Undervoltage trip—instantaneous or time delay type. Trips the breaker on 30-60% undervoltage.
- Overcurrent trip switch operates and latches when breaker is automatically tripped on overload or fault conditions.
- Electric lockout for manually operated breakers
- Electric close release for manually operated breakers
- Key interlocks
- Operations counter
- AC capacitor trip
- Integral ground fault sensing
- Insulated switchgear bussing
- UL Label (except DS-850)



Breaker Lifting Device



POWER-ZONE® III
Low Voltage Metal-Enclosed Drawout Switchgear
Ratings – Layout – Dimensions

Ratings

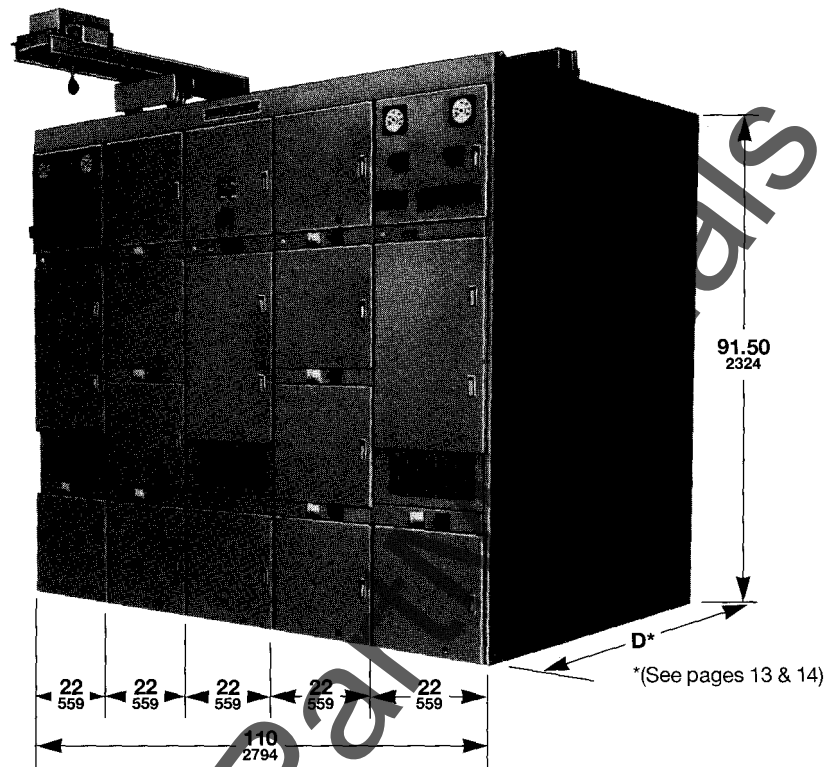

Table A
Interrupting Ratings of Type DS Circuit Breaker (RMS Symmetrical Amperes)

Trip Current Range	Breaker Type	w/Instantaneous Trip			w/Short Delay Trip		
		208-240V	480V	600V	208-240V	480V	600V
50-800	DS-206	42,000	30,000	30,000	30,000	30,000	30,000
50-800	DS-206H	50,000	42,000	42,000	42,000	42,000	42,000
50-800	DS-206E	65,000	65,000	50,000	42,000	42,000	42,000
50-1600	DS-416	65,000	50,000	42,000	50,000	50,000	42,000
50-1600	DS-416H	65,000	65,000	50,000	65,000	65,000	50,000
50-2000	DS-420	65,000	65,000	50,000	65,000	65,000	50,000
800-3200	DS-632	85,000	65,000	65,000	65,000	65,000	65,000
1000-4000	DS-840	130,000	85,000	85,000	85,000	85,000	85,000
1600-5000	DS-850①	130,000	85,000	85,000	85,000	85,000	85,000
50-800	DSL-206	All Ranges: 200,000					
50-1600	DSL-416						
800-3200	DSL-632						
1000-4000	DSL-840						

Table B
Available Sensors

Breaker Type	Sensor Rating (Amperes)
DS-206, DSL-206, DS-206H, DS-206E	200, 300, 400, 600, 800
DS-416, DSL-416, DS-416H	200, 300, 400, 600, 800, 1200, 1600
DS-420	200, 300, 400, 600, 800, 1200, 1600, 2000
DS-632	2400, 3200
DS-840	4000
DS-850①	5000

①DS-850 - Forced air cooled; not UL Listed - For applications, consult headquarters.

Table C
Available Rating Plugs

Sensor Rating Amperes	Plug Rating in Amperes
200	100, 200
300	200, 250, 300
400	200, 250, 300, 400
600	300, 400, 600
800	400, 600, 800
1200	600, 800, 1000, 1200
1600	800, 1000, 1200, 1600
2000	1000, 1200, 1600, 2000
2400	1600, 2000, 2400
3200	1600, 2000, 2400, 3200
4000	2000, 2400, 3000, 3200, 4000
5000	3200, 4000, 5000



POWER-ZONE® III

Low Voltage Metal-Enclosed Drawout Switchgear

Ratings - Layout - Dimensions

Layout

Approximate Dimensions—Not for Construction

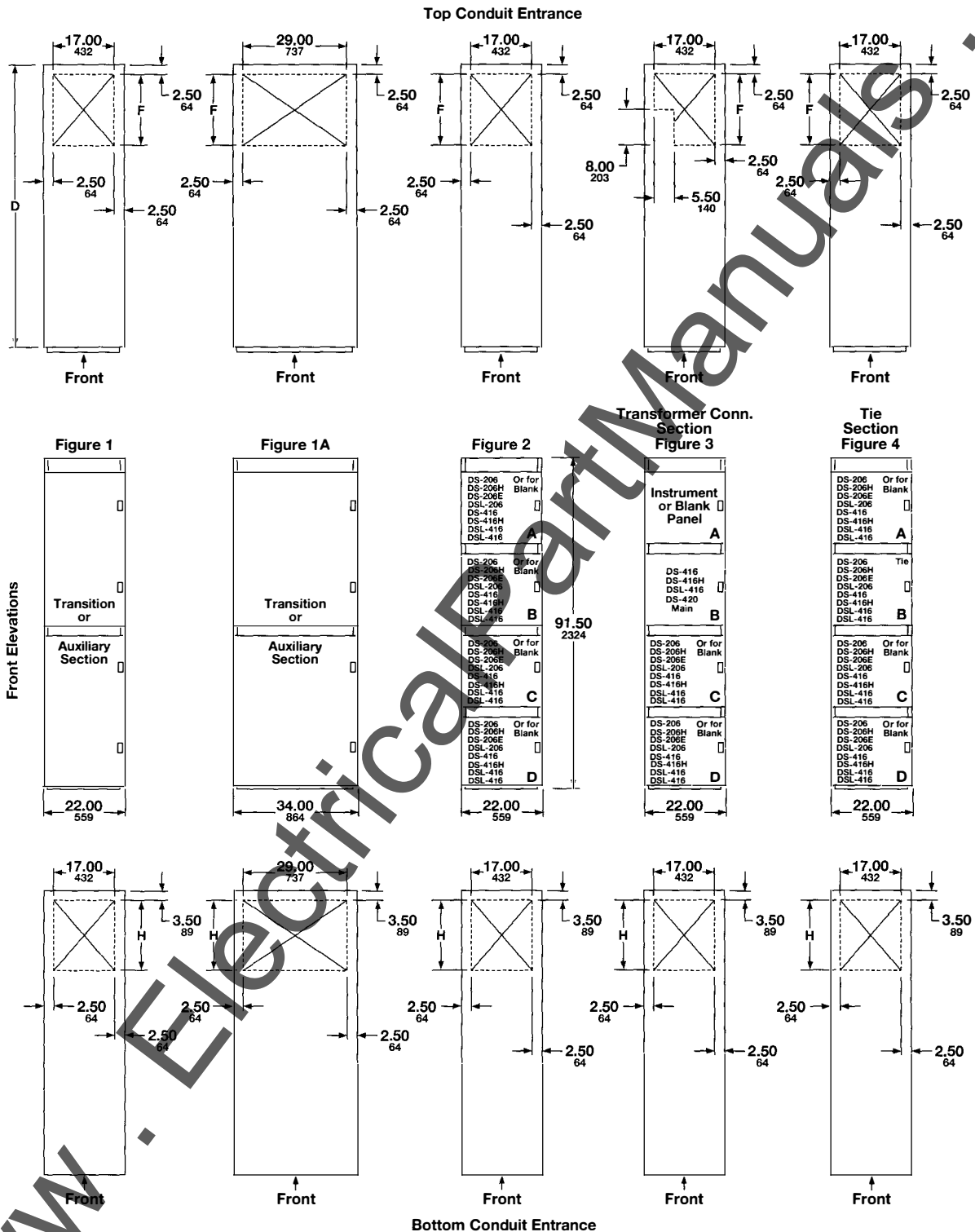

Dual Dimensions: INCHES
Millimeters



POWER-ZONE[®] III
Low Voltage Metal-Enclosed Drawout Switchgear
Ratings - Layout - Dimensions

Layout

Approximate Dimensions—Not for Construction

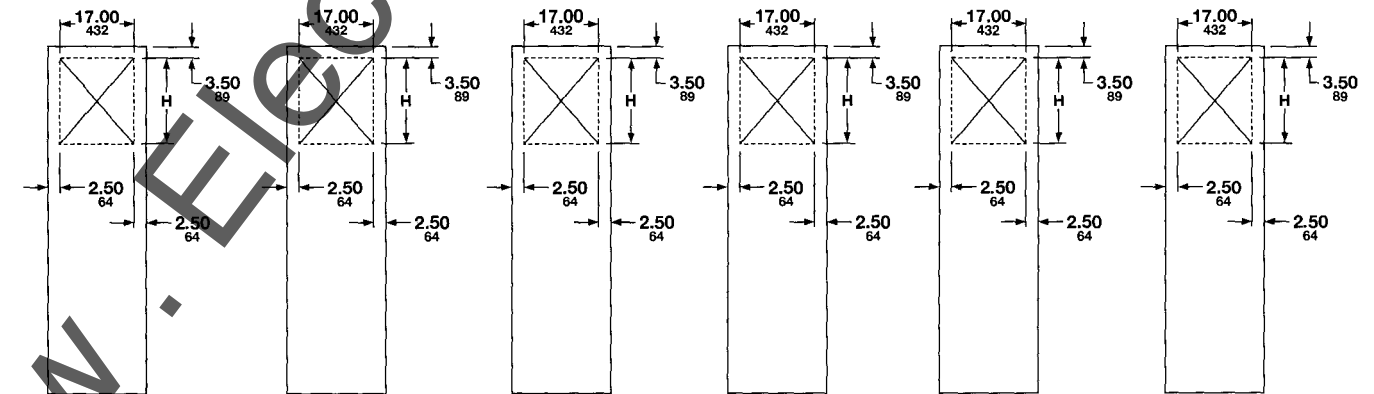
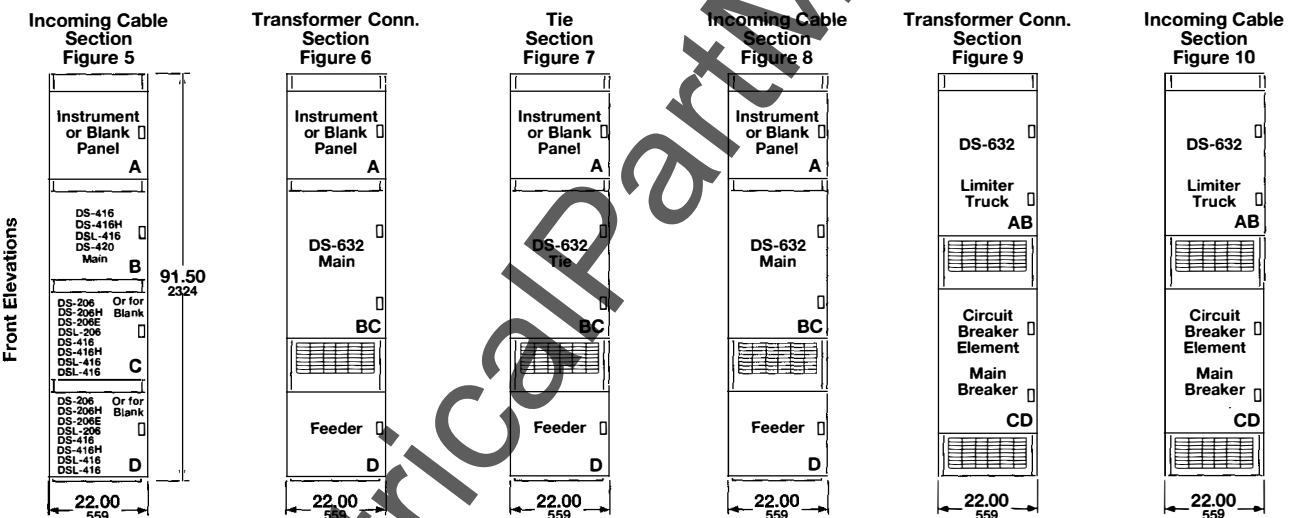
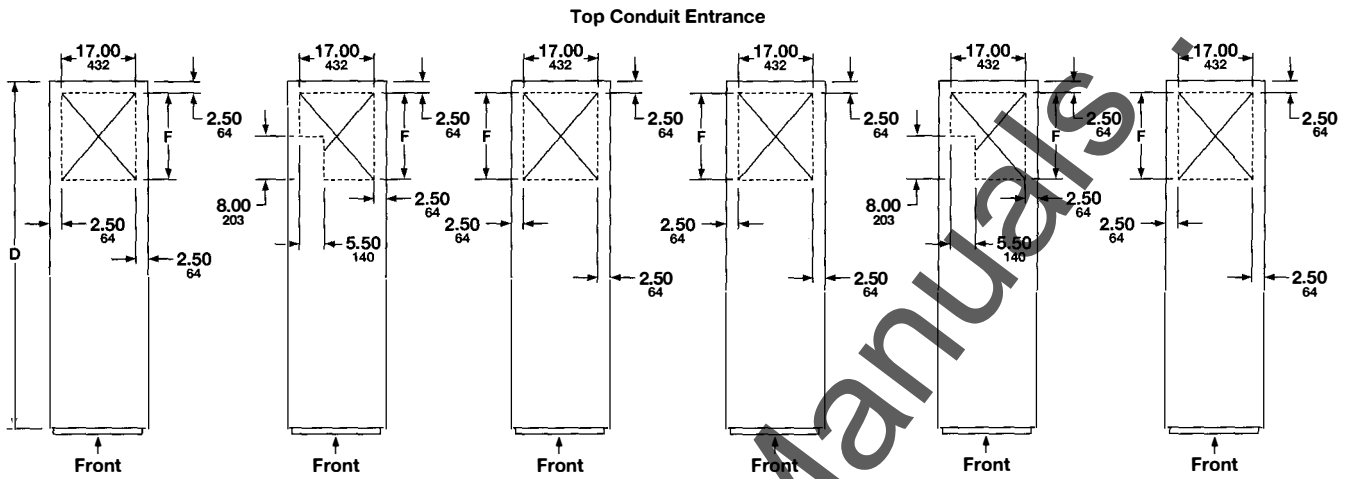

Dual Dimensions: **INCHES**
 Millimeters



SQUARE D

POWER-ZONE® III

Low Voltage Metal-Enclosed Drawout Switchgear

Ratings – Layout – Dimensions

Layout

Approximate Dimensions—Not for Construction

www.ElectricalPartManuals.com

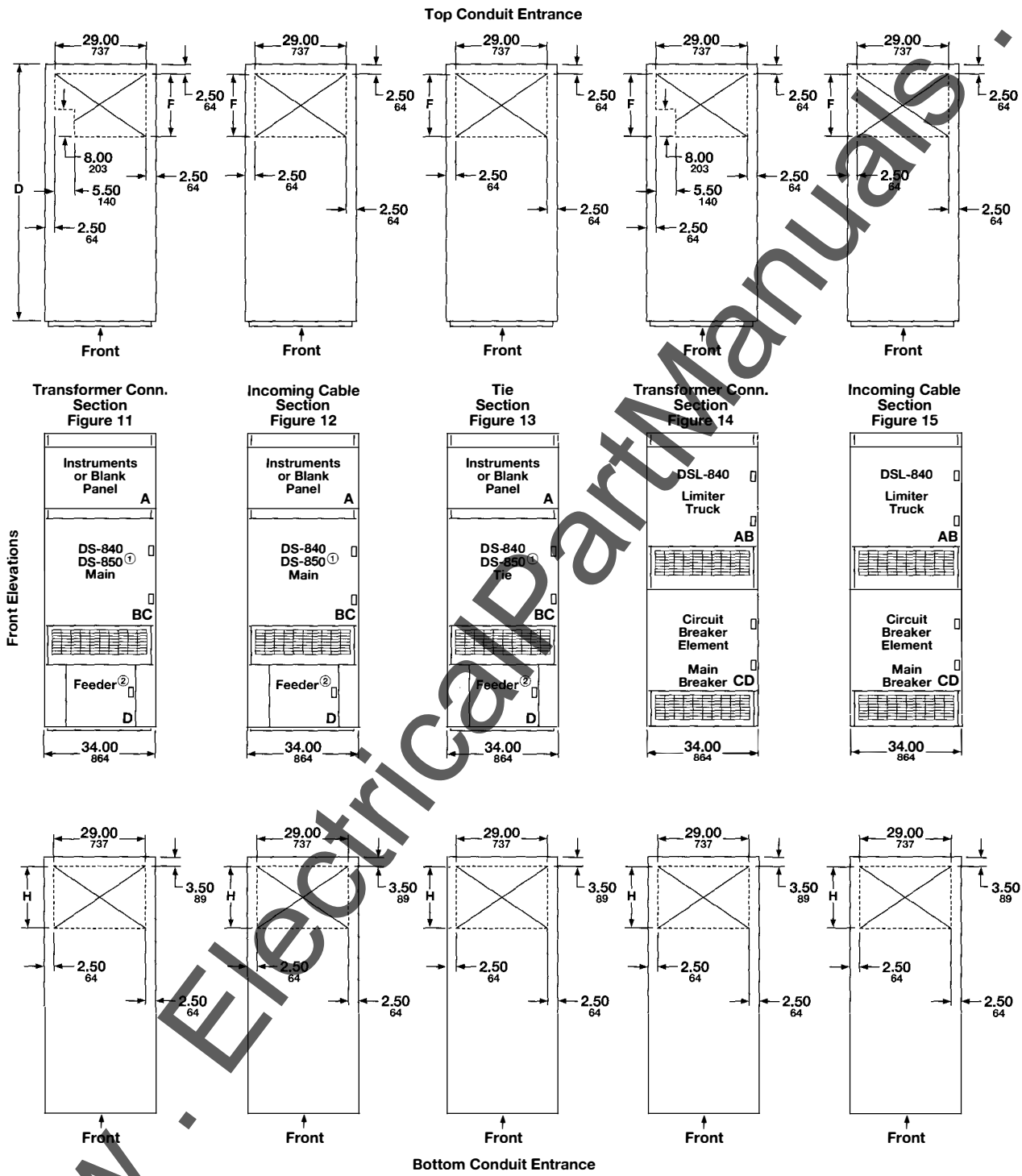

① DS-850 - Forced air cooled; not UL Listed. For applications, consult headquarters.
 ② No feeder permitted with DS-850.

Dual Dimensions: **INCHES**
 Millimeters

www.ElectricalPartManuals.com



POWER-ZONE® III
Low Voltage Metal-Enclosed Drawout Switchgear
Ratings – Layout – Dimensions

Dimensions

Indoor Construction

Approximate Dimensions–Not for Construction

Bus Size	Breaker Type	Section Depth D		Figure 1, 1A Transition Aux. Unit				Figure 2 Incoming Unit/ 4 High for Unit				Figure 3 Transformer Main Unit				Figure 4 Tie Unit			
				IN		MM		IN		MM		IN		MM		IN		MM	
		IN	MM	F	H	F	H	F	H	F	H	F	H	F	H	F	H	F	H
1600A or 2000A	DS	55.13	1400	14.5	13.5	368	343	14.5	6.5	368	165	9.0	6.5	229	165	14.5	6.5	368	165
		60.13	1527	19.5	18.5	495	470	19.5	11.5	495	292	14.0	11.5	356	292	19.5	11.5	495	292
		72.13	1832	31.5	30.5	800	775	31.5	23.5	800	597	26.0	23.5	660	597	31.5	23.5	800	597
1600A or 2000A	DSL	63.13	1604	14.5	13.5	368	343	14.5	6.5	368	165	9.0	6.5	229	165	14.5	6.5	368	165
		68.13	1731	19.5	18.5	495	470	19.5	11.5	495	292	14.0	11.5	356	292	19.5	11.5	495	292
		80.13	2035	31.5	30.5	800	775	31.5	23.5	800	597	26.0	23.5	660	597	31.5	23.5	800	597
3200A	DS	55.13	1400	14.5	13.5	368	343	14.5	6.5	368	165	14.5	6.5	368	165
		60.13	1527	19.5	18.5	495	470	19.5	11.5	495	292	19.5	11.5	495	292
		72.13	1832	31.5	30.5	800	775	31.5	23.5	800	597	31.5	23.5	800	597
3200A	DSL	63.13	1604	14.5	13.5	368	343	14.5	6.5	368	165	14.5	6.5	368	165
		68.13	1731	19.5	18.5	495	470	19.5	11.5	495	292	19.5	11.5	495	292
		80.13	2035	31.5	30.5	800	775	31.5	23.5	800	597	31.5	23.5	800	597
4000A 5000A*	DS/DSL (Except DS/DSL-840 & DS-850)	63.13	1604	14.5	13.5	368	343a	14.5	6.5	368	165
		68.13	1731	19.5	18.5	495	470a	19.5	11.5	495	292
		80.13	2035	31.5	30.5	800	775a	31.5	23.5	800	597
(See Notes) →				(b,d)				(b,c)				(b,c,d)							

Bus Size	Breaker Type	Section Depth D		Figure 5 Cable-in Main				Figure 6 Transformer Main Unit				Figure 7 Tie Unit				Figure 8 Cable-in Main			
				IN		MM		IN		MM		IN		MM		IN		MM	
		IN	MM	F	H	F	H	F	H	F	H	F	H	F	H	F	H	F	H
1600A or 2000A	DS	55.13	1400	14.5	6.5	368	165
		60.13	1527	19.5	11.5	495	292
		72.13	1832	31.5	23.5	800	597
1600A or 2000A	DSL	63.13	1604	14.5	6.5	368	165
		68.13	1731	19.5	11.5	495	292
		80.13	2035	31.5	23.5	800	597
3200A	DS	55.13	1400	9.0	6.5	229	165	14.5	6.5	368	165	...	6.5	...	165
		60.13	1527	14.0	11.5	356	292	19.5	11.5	495	292	19.5	11.5	495	292
		72.13	1832	26.0	23.5	660	597	31.5	23.5	800	597	31.5	23.5	800	597
3200A	DSL	63.13	1604	14.5	6.5	368	165
		68.13	1731	19.5	11.5	495	292
		80.13	2035	31.5	23.5	800	597
4000A 5000A*	DS/DSL (Except DS/DSL-840 & DS-850)	63.13	1604	14.5	6.5	368	165
		68.13	1731	19.5	11.5	495	292
		80.13	2035	31.5	23.5	800	597
(See Notes) →				(b,d)				(b,c)				(b,c,d)				(b,c,d)			

Note: Conduit areas are for mechanical connectors. For compression lug conduit area, consult headquarters.
a) Transformer or auxiliary Unit Fig. 1A only.
b) Conduit area for bottom (H) increases by 7 in./177.8 mm when there is no breaker in the bottom cell.
c) When a bus duct is used in this unit the top entrance (F) is decreased, consult headquarters for area.
d) Service entrance barrier and other barriers change conduit area, consult headquarters for area.
e) This unit has a through bus connection, for a 'CD' feeder-consult headquarters.
*5000A applications – consult headquarters.



POWER-ZONE® III
Low Voltage Metal-Enclosed Drawout Switchgear
Ratings – Layout – Dimensions

Dimensions

Indoor Construction

Approximate Dimensions—Not for Construction

Bus Size	Breaker Type	Section Depth D		Figure 9 Transformer Main				Figure 10 Cable-in Main				Figure 11 Transformer Main Unit				Figure 12 Cable-in Main			
				IN		MM		IN		MM		IN		MM		IN		MM	
		IN	MM	F	H	F	H	F	H	F	H	F	H	F	H	F	H	F	H
3200A	DSL	63.13	1604	9.0	8.75	229	222
		68.13	1731	14.0	13.75	356	349	19.5	13.75	495	349
		80.13	2035	26.0	25.75	660	654	19.0	25.75	483	654
4000A 5000A*	DS/DSL 840	63.13	1604	6.5	...	165	
		68.13	1731	6.5	11.5	165	292	19.5	11.5	495	292
	DS-850*	80.13	2035	18.5	23.5	470	597	31.5	23.5	800	597	
(See Notes) →		(c,e)				(c,d)				(b,c)				(b,d)					

Bus Size	Breaker Type	Section Depth D		Figure 13 Tie Unit				Figure 14 Transformer Main				Figure 15 Cable-in Main			
				IN		MM		IN		MM		IN		MM	
		IN	MM	F	H	F	H	F	H	F	H	F	H	F	H
3200A	DSL	63.13	1604
		68.13	1731
		80.13	2035
4000A 5000A*	DS/DSL 840	63.13	1604	14.5	6.5	368	165	...	8.5	...	216
		68.13	1731	19.5	11.5	495	292	6.5	12.5	165	317	19.5	13.75	495	349
	DS-850*	80.13	2035	31.5	23.5	800	597	18.5	24.5	470	622	19.0	17.75	483	451
(See Notes) →		(b,c,d)				(c)				(c,d)					

Note: Conduit areas are for mechanical connectors. For compression lug conduit area, consult headquarters.

- a) Transformer or auxiliary Unit Fig. 1A only.
- b) Conduit area for bottom (H) increases by 7 in./177.8 mm when there is no breaker in the bottom cell.
- c) When a bus duct is used in this unit the top entrance (F) is decreased, consult headquarters for area.
- d) Service entrance barrier and other barriers change conduit area, consult headquarters for area.
- e) This unit has a through bus connection, for a 'CD' feeder—consult headquarters.
- * 5000A applications – consult headquarters.

Type of Device	Lbs.	Kg.
DS-206 Breaker	175	79.4
DS-206H Breaker	180	81.7
DS-206E	180	81.7
DS-416 Breaker	180	81.7
DS-416H Breaker	185	83.9
DS-420 Breaker	180	81.7
DS-632 Breaker	300	136.0
DS-840 Breaker	405	83.7
DS-850 Breaker	405	83.7

Type of Device	Lbs.	Kg.
DSL-206 Breaker	205	93.0
DSL-416 Breaker	255	115.7
DSL-632 Limiter Truck	325	147.4
DSL-840 Limiter Truck	430	195.0
4-high unit without breakers (22")	150	725.8
Unit without breakers (34")	260	1179.3
Auxiliary unit without devices	500	226.8

Recommended Minimum Clearance:
 Front - 42" (1050mm)
 Rear - 42" (1050mm)
 Ref. See NEC Article 110-16



POWER-ZONE® III Low Voltage Metal-Enclosed Drawout Switchgear Suggested Specifications

General

The specifications and associated drawings describe the indoor low voltage metal-enclosed drawout switchgear assembly. The assembly is to be designed for use on a _____ volt, (single) (3) phase, _____ wire (50) (60) Hz. system, with _____ amperes symmetrical fault current available. Equipment is to be complete from the incoming line connections to the outgoing feeder connections. Any items not specifically mentioned but obviously necessary for proper operation are implied in this description.

The low voltage section shall be POWER-ZONE III switchgear, as manufactured by the Square D Company, or approved equal, designed, manufactured and tested in accordance with applicable standards for power circuit breakers and metal-enclosed switchgear.

Applicable Standards:

Structures:	Circuit Breakers:
NEMASG5	NEMA SG3
ANSI C37.20.1	ANSI C37.13
ANSI C37.51	ANSI C37.16
UL 1558 (Optional) ^①	UL 1066 (Optional) ^①

The enclosure shall be finished with medium gray ANSI #49 enamel applied over a rust inhibiting phosphate primer. (Equipment shall be equipped with) (Service Entrance Label) (and) (UL 1558 label for metal-enclosed low voltage power circuit breaker type switchgear assemblies when UL recognized components are specified.) (Not required for assemblies with forced air cooled 5000A breakers.)

Enclosure

The enclosure and internal barriers shall be fabricated of steel members in accordance with NEMA and ANSI standards. Steel lifting straps are to be provided with each shipping group to lift the structure from top with a crane. Supply a wooden skid to permit the use of pipe rollers for moving the switchgear to its final location in the building.

All vertical sections shall be bolted together. Ventilation openings on the front of the switchgear breaker compartments are to be located in such a way as to preclude the possibility of metal objects being inserted through them and easily contacting energized parts. To barrier operator from escaping gases during an interruption, breakers shall be supplied with a steel front plate when ventilation openings are on the front of the breaker compartment door.

The equipment shall be assembled, adjusted and tested at the factory and shall be sectionalized, if required, for shipping as requested or approved. The largest section is not to exceed _____ inches wide, _____ inches deep, and _____ high to enable installation at the job site.

The structure is to consist of three basic compartments from front to rear: the front breaker compartment, the center bus compartment, and the rear cable compartment.

Front Breaker Compartment

The front breaker compartment is to contain the drawout circuit breaker elements, each mounted in its own barriered cell. Active or future use cells shall be equipped to accept circuit ^①Not required for 5000A breaker.

breaker drawout mechanism and contain all current carrying parts. Provide each breaker cell with a hinged door equipped with a flush handle and an external trip button. When equipped with a breaker, a double steel barrier shall exist between operating personnel, the breaker mechanism and live parts. Thus, the breaker can be operated with outer steel door open.

If breaker protrudes through a hole in the circuit breaker compartment door, shutters shall be provided to shield live parts when circuit breaker is out for service. Also, a steel plate shall be provided for the opening in the circuit breaker compartment door to preclude the possibility of foreign objects entering the breaker cell when breaker is removed.

Center Bus Compartment

The bus compartment is to contain the section riser and main cross bus which is to be rated for a 65°C. temperature rise per ANSI standards. The main cross bus shall be rated for _____ continuous amperes. All main and riser bus shall be bolted copper and adequately braced so to be applied on a system capable of supplying rms symmetrical amperes of short circuit current of 50kA, (100kA), (150kA), (200kA). All contact surfaces at bolted joints shall be fully silver plated and the joint bolts are to be of high strength grade 5 steel equipped with Belleville type spring washers. Riser bus shall meet industry standard phase-to-phase clearance without the use of insulated/isolated bus. All electrical clearances are to be for 600VAC. (An isolated neutral bus is to be supplied rated at (50) (100) percent of the phase current.)

Rear Cable Compartment

Size the cable compartment to accommodate all incoming and outgoing cable required within each vertical switchgear section. Cable lugs are to be mounted on the load side (or line side as applicable) run-back bus which is extended into this compartment from the bus compartment. Run-back bus for main or feeder breakers to be insulated from the section riser and cross bus. This compartment shall also contain a copper ground bus bolted directly to the switchgear frame. (Extend a neutral run-back into the cable compartment for connecting the neutral to the ground bus with a removable isolating link.) (Clamp type cable lugs suitable for use with aluminum or copper cable are to be supplied as shown on the plans.)

(Option 1)

The center bus compartment containing the section riser bus and main cross bus shall be segregated from the rear cable compartment by means of grounded metal barriers. Using plastic covers over bus in lieu of rear barriers for this safety precaution is not acceptable.

Circuit Breakers

The circuit breakers shall be the drawout type, manually or electrically operated type DS (DSL) as shown on the associated drawings or as listed in the equipment tabulation. The breakers are to mount on a rigid self-aligning drawout mechanism with "connected", "test", "disconnected", and "removed" positions. The front door shall be capable of being closed in the "connected", "test", or "disconnected" positions. Provide interlocks to ensure the breaker is open before it can be moved from any position or when it is between positions. Include an



POWER-ZONE® III

Low Voltage Metal-Enclosed Drawout Switchgear

Suggested Specifications

interlock to discharge the stored energy spring before the breaker element can be withdrawn from its cell. In the "test" and "connected" positions, provide a positive ground contact between the breaker element and the structure.

Breakers of like frame sizes shall be interchangeable as standard. No special structural bracing will be required. All circuit breaker operating mechanisms are to be fully stored energy devices with a two-step stored energy quick-make, quick-break. Actuation of the operating handle or an operation cycle of the breaker motor is to charge the closing springs and operation of a local "close" button is to close the breaker contact. Closing of the breaker contacts shall automatically charge the opening springs to ensure quick-break operation.

Low voltage power breaker arc chutes containing asbestos will by no means be accepted.

(Breakers of 5000A frame size may be forced air cooled.)

The circuit breaker trip device is to be of a microprocessor design which requires no external power connections and is provided with an adjustable long-time delay, instantaneous (and short-time delay) over-current/short circuit protection. (Include ground fault tripping as an integral part of the microprocessor trip device.) Internal self-testing of the unit shall be provided. Indicators for overload, short circuit and ground trip shall be provided. (Breakers are to have UL label.) (UL label not required for 5000A forced air cooled breakers.)

(The trip unit shall be capable of measuring AC phase currents, power, energy, trip level, and show cause of trip. The trip unit shall be able to communicate this information, as well as permit remote operation of the breaker, via the Square D POWERLOGIC and/or SY/NET communications network.)

Padlocking provisions shall be furnished to receive up to three padlocks when breaker is in the open position, positively preventing unauthorized closing of the breaker contacts. A manual trip button and position indicator shall be furnished on all breakers. "Push to Close" button shall be conveniently located on face of breaker for easy access, thereby avoiding the need to reach behind or around other devices located on the face of the breaker.

(Include the following only when type DSL breakers are specified:) (Circuit breakers shall be equipped with current limiters. Current limiters shall be integrally mounted on 800A and 1600A frame sizes and separately mounted on 3200A and 4000A frame sizes. Equip each breaker with a blown limiter indicator visible from the front of the breaker, and with an anti-single phase device which will trip the breaker when any limiter blows, and which will prevent reclosing the breaker on a single phase condition resulting from blown or missing limiters.)

The following equipment shall be provided:

(1)(2) _____ Type DS- _____ main breaker(s), _____ ampere frame, 3-pole, (manually) (electrically) operated.

Tripping sensors rated _____ amperes.

_____ Type DS- _____ tie breaker, _____ ampere frame, 3-pole, (manually) (electrically) operated. Tripping sensors rated _____ amperes.

_____ Type DS- _____ feeder breaker(s), _____ ampere frame, 3-pole, (manually) (electrically) operated. Tripping sensors rated _____ amperes.

_____ Type DS- _____ feeder breaker(s), _____ ampere frame, 3-pole, (manually) (electrically) operated. Tripping sensors rated _____ amperes.

Metering Components

Main Bus

(1)(2) _____ POWERLOGIC circuit monitor model _____*

(1)(2) _____ (2%) (1%) voltmeter and 3-phase selector switch with OFF position.

(1)(2) _____ (2%) (1%) ammeter and 3-phase selector switch with OFF position.

(1)(2) _____ Watthour meter, (2) (2½) (3) element type, (with) (without) demand register.

_____ Current transformer, suitable ratio.

_____ Potential transformer, suitable ratio.

Feeder Circuits

_____ POWERLOGIC circuit monitor model _____*

_____ 2% ammeter and 3-phase selector switch with OFF position.

_____ Current transformer, suitable ratio.

(Option 2)

A portable testing device shall be provided.

(Option 3)

A top mounted traveling breaker lifting device shall be provided.

* _____ () Indicates a selection is to be made for quantity or applicability.

*(A complete line of POWERLOGIC circuit monitors and control systems is available for POWER-ZONE III switchgear. Consult your local Square D sales office.)

For further information about POWER-ZONE III Switchgear, contact your local Square D sales office. They're conveniently located in over 160 cities throughout the U.S. and abroad to serve you: or, write to PZIII Marketing Section, Square D Company, 330 Weakley Rd., Smyrna, TN 37167.

POWER-ZONE, POWER ZONE, POWERLOGIC, SQUARE D, and  are Registered Trademarks of Square D Company.

Digitrip is a Registered Trademark of Cutler-Hammer/Eaton Corp.

