

# Type AMR Medium Voltage Replacement Circuit Breakers

ANSI 5kV at 250–350 MVA, 1200-2000 Amperes



5-AMR  
(Replacement for  
Allis-Chalmers AM)

Replacement breakers provide a cost-effective way to upgrade your system capabilities while saving you from costly maintenance and lost productivity while preserving your investment in existing cubicles and cables.

Siemens provides the experience your company needs to successfully extend the life of your equipment. Our circuit breakers are manufactured using the same fixtures as the original Allis-Chalmers breakers.

## Why Replacement Breakers?

- Increased Reliability and Performance
- Reduced Operating and Maintenance Expenditures
- Reduced Downtime, Minimal Changeover Time During Upgrade
- Preserved Investment in Existing Cubicles
- Improved Employee and Environmental Safety

## Why Siemens?

Siemens Offers the Best Vacuum Circuit Breaker in the Industry.

- Superior Performance, Longer Service Life
  - 10,000 full load operation, 10-year maintenance cycle on replacement circuit breakers with 3AH operator
- Standard Operator on All Siemens Replacement, Medium Voltage Distribution, and Outdoor Vacuum Circuit Breakers
  - Reduced part count and inventory
  - Minimized maintenance training required
- Extensive Replacement Breaker Experience – 750+ projects since 1983
  - Over 300,000 3AF/H series circuit breakers in service worldwide
  - Nuclear 1E Rated (350+ breakers)
  - Design, Production Testing per ANSI, IEEE
- Full Range of Service Capabilities by Skilled Factory-Trained Engineers

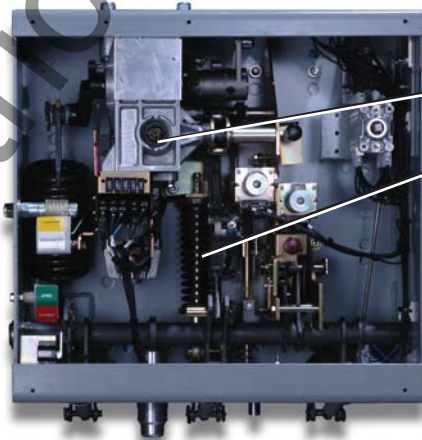

## 3AH Operator Features:

- Spring charge motor mechanism - lifetime lubricated gear box
- Operating linkage - machine parts vs. stamped metal
- Change-out of components - easily accessible
- Vacuum contact erosion indication - easily verifiable

## Siemens Type AMR Medium Voltage Vacuum Circuit Breakers For Allis-Chalmers Type AM

The following circuit breakers are available as pre-engineered designs.

Replacement Circuit Breaker	Nominal Voltage Class	Nominal 3-Phase MVA Class	Maximum Voltage	Voltage Range Factor	Interrupting Time	Full Wave Withstand Test Voltage	Continuous Current (60 Hz)	Short Circuit Current (at max. kV)	Close and Latch Capability	Nominal Weights
			E	K				I	1.6 x KI	
	kV	MVA	kV rms		Cycles	kV Peak	Amperes	kA rms	kA rms	lbs.
5 AMR-250	4.16	250	4.76	1.24	5	60	1200, 2000	29	58	750
5 AMR-350	4.16	350	4.76	1.19	5	95	1200, 2000	41	78	800

Dimensions (Inches)	
	5 AMR 250/350
A	65.47
B	21.32
C	11.00
D	19.85
E	25.37

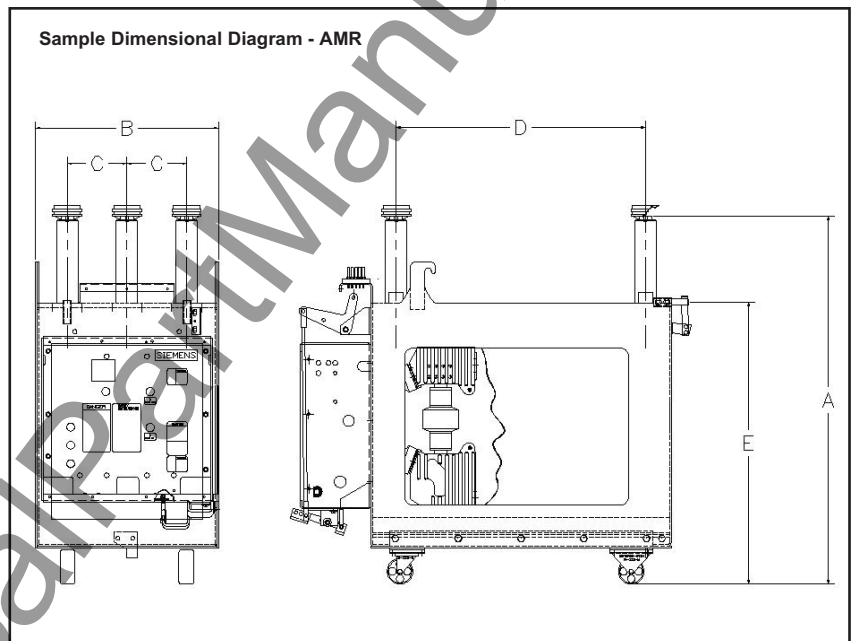

### Contact Us

To find out more about Siemens replacement breakers, please contact your local Siemens representative or (800) 347-6659 regarding your site specific application.

Siemens Power Transmission & Distribution, Inc.  
Service Solutions Division  
7000 Siemens Road  
Wendell, NC 27591  
[www.usa.siemens.com/energy](http://www.usa.siemens.com/energy)

© 2007 Siemens Power Transmission & Distribution, Inc.  
All rights reserved.  
E 5601-U610-A134-X-US00  
Subject to change without notice.

All statements, technical information and recommendations contained herein are based on information and tests we believe to be reliable. The accuracy or completeness hereof is not guaranteed. Since conditions of use are outside our control, the user should determine the suitability of the product for its intended use and assumes all risk and liability whatsoever in connection herewith.