

SIEMENS-ALLIS

Phil

Installation • Operation • Maintenance

Instructions

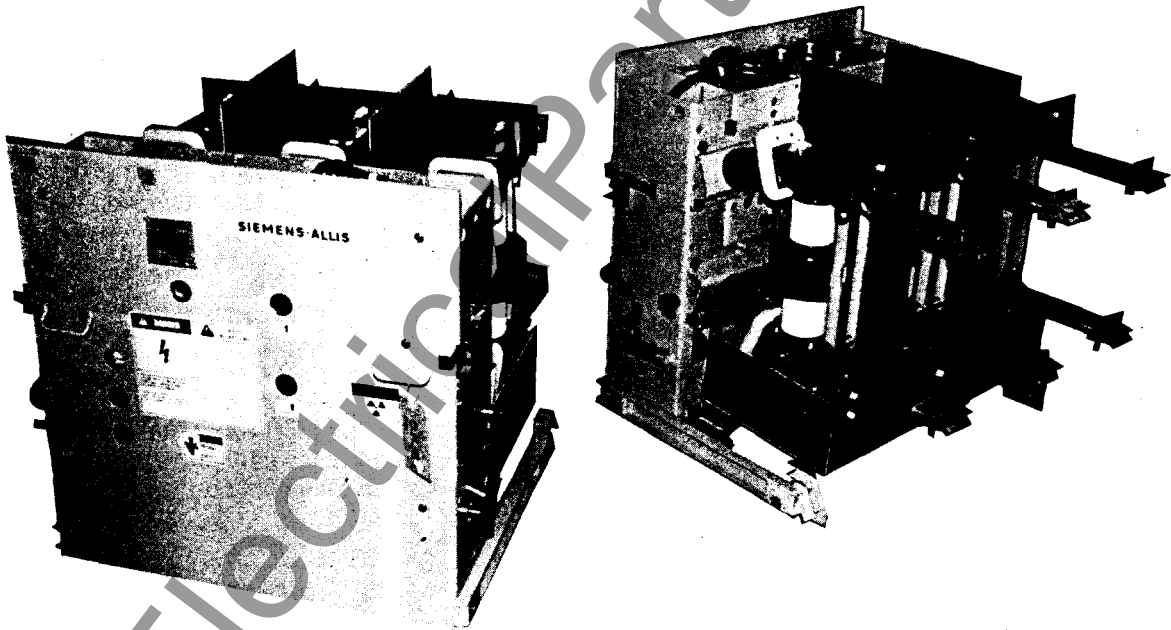

Type -3AF- Vacuum Circuit Breakers
5-3AF-250, 5-3AF-350, 7-3AF-500
15-3AF-500, 15-3AF-750, 15-3AF-1000
SG-3158

www.ElectricalPartManuals.com

INTRODUCTION

THIS EQUIPMENT CONTAINS HAZARDOUS VOLTAGES AND MECHANICAL PARTS WHICH MOVE AT HIGH SPEED AND MAY BE CONTROLLED REMOTELY. SEVERE PERSONAL INJURY OR PROPERTY DAMAGE CAN RESULT IF SAFETY INSTRUCTIONS ARE NOT FOLLOWED. ONLY QUALIFIED PERSONNEL SHOULD WORK ON OR AROUND THIS EQUIPMENT AFTER BECOMING THOROUGHLY FAMILIAR WITH ALL WARNINGS, SAFETY NOTICES, AND MAINTENANCE PROCEDURES CONTAINED HEREIN. THE SUCCESSFUL AND SAFE OPERATION OF THIS EQUIPMENT IS DEPENDENT UPON PROPER HANDLING, INSTALLATION, OPERATION AND MAINTENANCE.

Qualified Person

For the purpose of this manual and on product labels, a qualified person is one who is familiar with the installation, construction and operation of the equipment, and the hazards involved. In addition, he has the following qualifications:

- (a) Is trained and authorized to energize, de-energize, clear, ground, and tag circuits and equipment in accordance with established safety practices.
- (b) Is trained in the proper care and use of protective equipment such as rubber gloves, hard hat, safety glasses or face shields, flash clothing, etc., in accordance with established safety practices.



Signal Words

Distinctive signal words (DANGER, WARNING, CAUTION) are used in this instruction book to indicate degrees of hazard that may be encountered by the user. These signal words are defined below.

Danger Indicates death, severe personal injury or substantial property damage will result if proper precautions are not taken.

Warning Indicates death, severe personal injury or substantial property damage can result if proper precautions are not taken.

Caution Indicates minor personal injury or property damage can result if proper precautions are not taken.

	 Danger
	<p>Power circuit breakers are applied at high voltages and have mechanical parts which move at high speeds and will cause death, personal injury and property damage.</p> <p>To avoid injuries due to electrical shock, burns, and entanglement in moving parts, this equipment must be installed, operated, and maintained only by qualified persons thoroughly familiar with the equipment, instruction manual and drawings.</p>

Field Service Operation

Siemens-Allis can provide competent, well-trained Field Service Representatives to provide technical guidance and advisory assistance for the installation, overhaul, repair and maintenance of Siemens-Allis equipment, processes and systems. Contact regional service centers, sales offices or factory for details.

www.ElectricalPartManuals.com

TABLE OF CONTENTS

Introduction		
Introduction	IFC	
Table of Contents	i	
Table of Illustrations	ii	
General		
Introduction	4	
Receiving	4	
"As Found" Tests	5	
Storage	5	
Installation Checkout	6	
Technical Data		
Rating Plate Content	8	
Rating Summary	9	
Breaker Type	9	
Service Conditions	9	
General Performance Data	10	
Interrupter/Operator - Description		
Description—General	11	
Description and Operation	11	
Construction	11	
Breaker Pole	13	
Current-Path Assembly	13	
Vacuum Interrupter	13	
The Arc-Quenching Principle	13	
Switching Operation	13	
Operating Mechanism	15	
Construction	15	
Indirect Releases	15	
Motor Operating Mechanism	15	
Auxiliary Switch	15	
Mode of Operation	15	
Charging	15	
Closing	16	
Trip Free Operation	16	
Opening	16	
Rapid Auto-Reclosing	16	
Interrupter/Operator (con't)		
Manual Operation	17	
Manually Charging The Closing Spring	17	
Manual Closing	21	
Manual Opening	21	
Elementary Diagram	21	
Indirect Releases	22	
Shunt Release	22	
Undervoltage Release	22	
Construction and Mode of Operation	23	
Interrupter/Operator - Maintenance		
General	24	
Inspection Checklist	24	
Hand Tools Recommended	24	
General	24	
Metric	24	
English	24	
Minimum Maintenance Schedule	25	
Lubrication of the Operating Mechanism	25	
Hydraulic Shock Absorber	27	
Vacuum Interrupters		
Life Expectancy	27	
Contact Erosion	27	
Interrupter Vacuum Check-Mechanical	28	
High Potential Testing and Electrical		
Interrupter Vacuum Check	29	
Vacuum Tube Replacement	30	
Solenoid Replacement	33	
Operational Check	33	
Vehicle - Description		
Description	34	
Alignment	34	
Interlocks	34	
Closed Breaker Racking Interlock	36	
Trip-Free Interlock	37	
Automatic Closing Spring Release	38	
Breaker Rating Interlock	38	
Connection to Secondary Disconnects	39	
Vehicle - Maintenance		
Vehicle Lubrication	40	
Warranty	IBC	

NOTE

The instructions contained within this manual are necessary for the safe installation, maintenance and operation of this equipment. If this manual is misplaced or lost, replacement manuals are available through the local Siemens-Allis sales office.

These instructions do not purport to cover all details or variations in equipment, nor to provide for every possible contingency, to be met in connection with installation, operation or maintenance. Should further information be desired or should particular problems arise which are not covered sufficiently for the purchaser's purposes, the matter should be referred to the local Siemens-Allis office.

THE CONTENTS OF THIS INSTRUCTION MANUAL SHALL NOT BECOME PART OF OR MODIFY ANY PRIOR OR EXISTING AGREEMENT, COMMITMENT OR RELATIONSHIP. THE SALES CONTRACT CONTAINS THE ENTIRE OBLIGATION OF SIEMENS-ALLIS. THE WARRANTY CONTAINED IN THE CONTRACT BETWEEN THE PARTIES IS THE SOLE WARRANTY OF SIEMENS-ALLIS. ANY STATEMENTS CONTAINED HEREIN DO NOT CREATE NEW WARRANTIES OR MODIFY THE EXISTING WARRANTY.

If drawings or other supplementary instructions for specific applications are forwarded with the manual or separately, they take precedence over any conflicting or incomplete information in this manual.

TABLE OF ILLUSTRATIONS

ii

Figure 1a.	Type 3AF Vacuum Circuit Breaker Front View	1
Figure b.	Type 3AF Vacuum Circuit Breaker Rear View.....	2
Figure c.	Type 15-3AF-500 Circuit Breaker in Test/Disconnect Position	3
Figure 2.	Rating Plate	8
Figure 3.	Typical Operator Housing	11
Figure 4.	Typical Interruptor/Operator Subassembly.....	12
Figure 5.	Section Through a Vacuum Breaker Pole.....	14
Figure 6.	Section Through a Typical Vacuum Interrupter	14
Figure 7.	Section Through the Typical Vacuum Breaker	14
Figure 8.	Operating Mechanism Closed Position - Closing Springs Discharged	15
Figure 9.	Details of Closing Spring Charging Components - Closing Springs Discharged	16
Figure 10.	Operating Mechanism Open Position - Closing Spring Charged	17
Figure 11.	Breaker Shaft in Open Position - Closing Springs Discharged.....	17
Figure 12.	Operating Mechanism Section Diagrams: a, b, c, d	18
Figure 13.	Operator Sequential Operation Diagram.....	20
Figure 14.	Front View of Mechanism Enclosure Arranged for Manual Operation	21
Figure 15.	Typical Elementary Diagram.....	22
Figure 16.	Construction of Shunt Release	23
Figure 17.a.	Latch Detail Shunt Release.....	23
Figure b.	Latch Detail Undervoltage Release	23
Figure c.	Undervoltage Blocking Feature.....	23
Figure 18.	Operator Lubrication Points	26
Figure 19.	Typical Primary Interrupter Contact Life Curves	27
Figure 20.	Contact Erosion Check	28
Figure 21.a.	Lower Pole Support with Insulated Coupler.....	28
Figure b.	Primary Contact Closed - Free Position.....	29
Figure c.	Primary Contact Forced Open by Manual Pressure	29
Figure 22.	Vacuum Tube Replacement Illustration	31
Figure 23.	Illustration Showing Required Technique for Fastening Terminal Clamp Hardware	32
Figure 24.	Drawout Truck Subassembly	35
Figure 25.	Closed Breaker Racking Interlock Plate Assembly	36
Figure 26.	Trip-Free Interlock Assembly	37
Figure 27.	Breaker Rating Interference Plate and Angle	38
Figure 28.	Secondary Disconnect Wiring	39
Table 1.	Rating Summary & Weights	9
Table 2.	Altitude Correction Factors.....	9
Table 3.	Operating Times	10
Table 4.	Closing and Tripping Solenoid Characteristics.....	10
Table 5.	Spring Charging Motor Characteristics.....	10
Table 6.	Auxiliary Switch Ratings	10
Table 7.	Maintenance Intervals	25
Table 8.	Rating Interlock Combination for Various Circuit Breaker Ratings	38

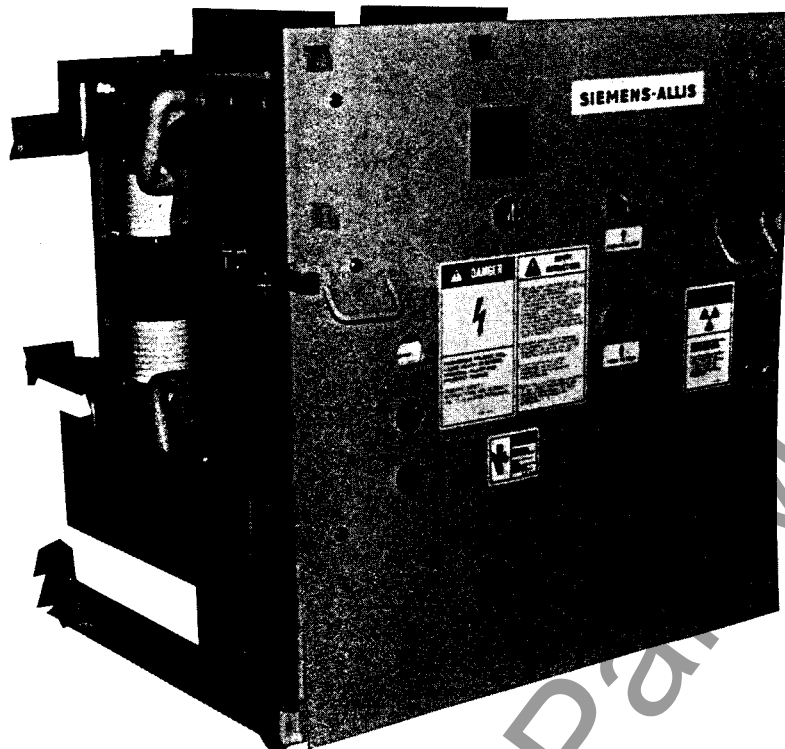

1a.1
15-3AF-500
1200A

1a.2
5-3AF-350
1200A
With Manual
Spring Charging Crank

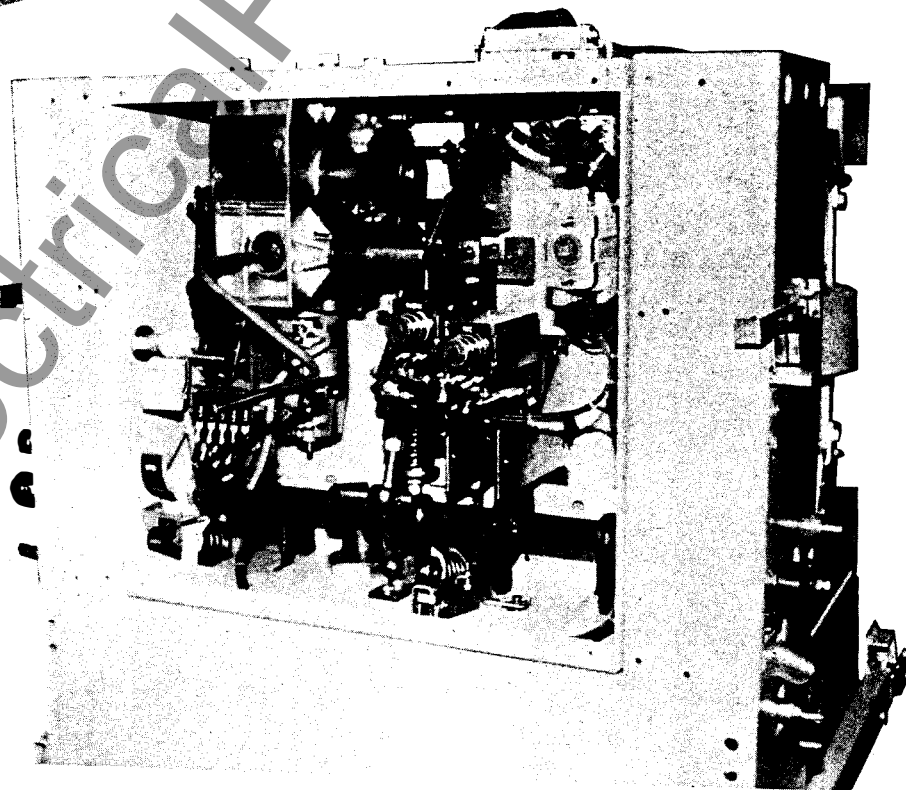

Figure 1a
Type 3AF Vacuum Circuit Breaker
Front View

GENERAL

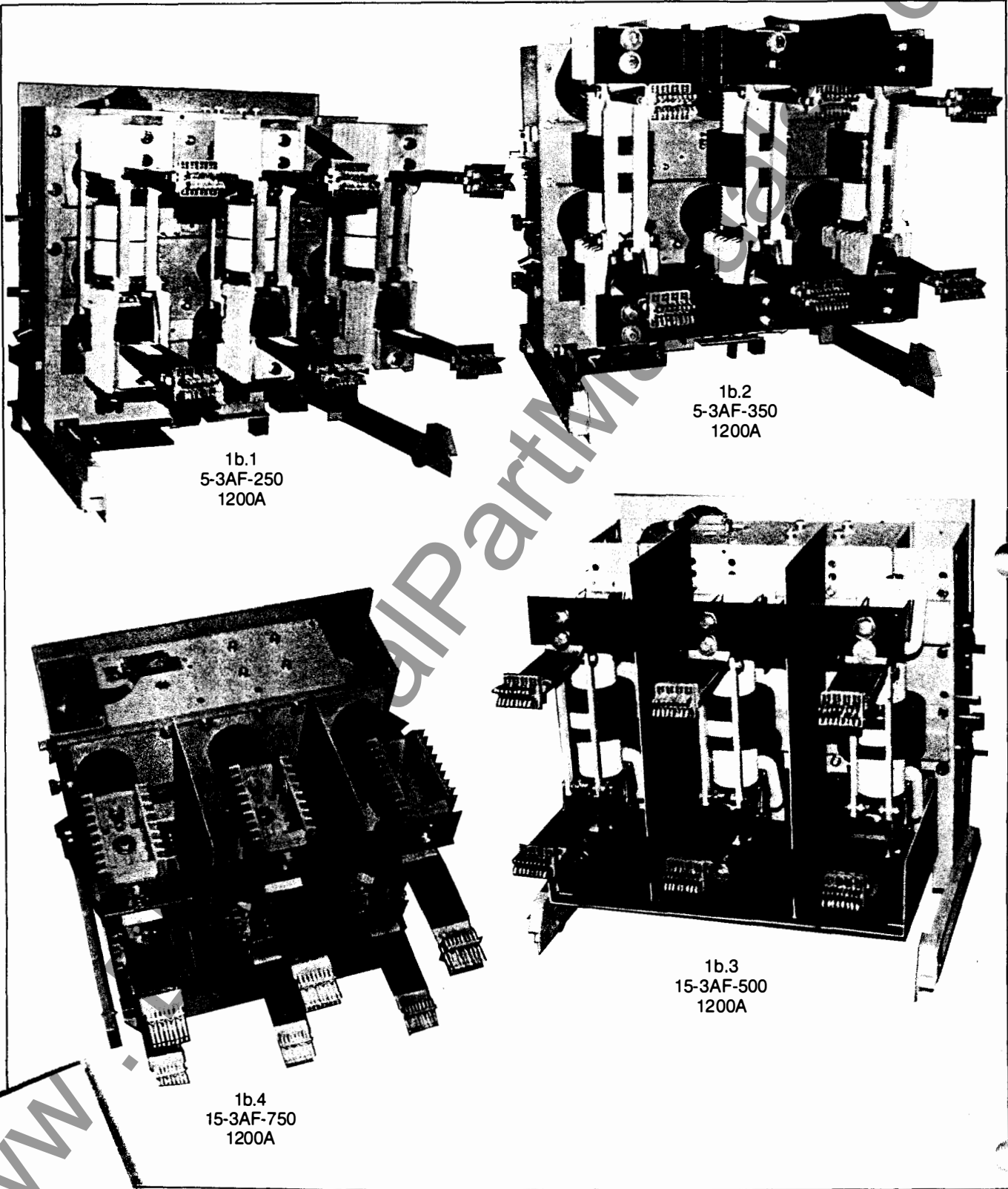

Figure 1b
Type 3AF Vacuum Circuit Breaker
Rear View



1c.1 Right Side of Cell

Screw Racking Mechanism Assembly

Racking Interlock Assembly

Trip-Free Interlock Assembly

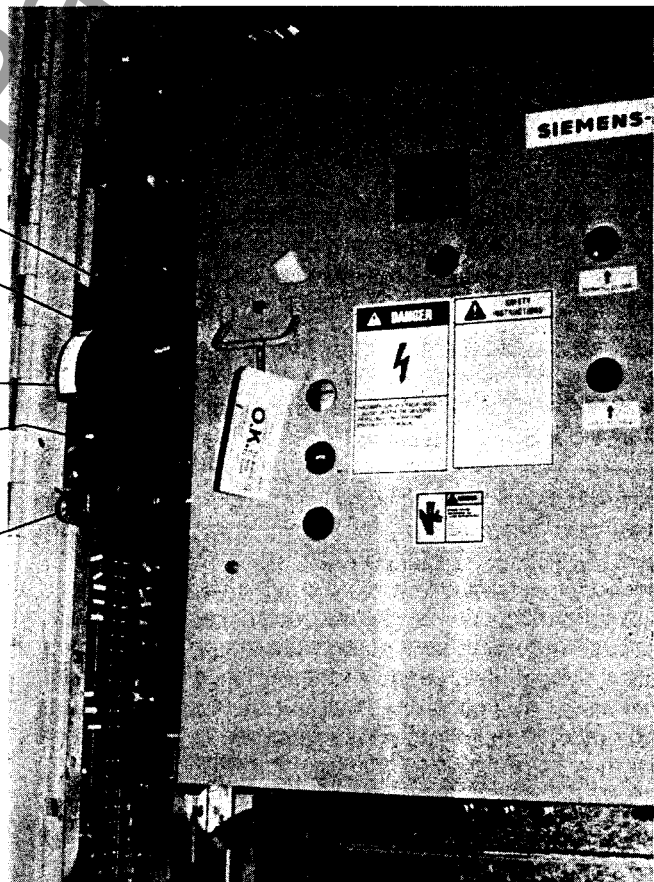

T3 Latch Disconnect

Racking Latch

Position Indicator

T2.1 Roller

Alignment Hole for Transfer Truck Guide Pin

1c.2 Left side of Cell

Figure 1c
Type 15-3AF-500 Circuit Breaker
in Test/Disconnect Position

GENERAL

Page 4

Introduction

The 3AF series of vacuum circuit breakers are precision built devices designed to function efficiently under normal operating conditions. They are designed and manufactured to operate within the ANSI C37 standards for "Indoor" oilless circuit breakers. Performance requirements of these standards are met or exceeded by these designs.

Specific Standards which apply include:

- C37.04 IEEE Standard Rating Structure
- C37.06 Preferred Ratings and Related Required Capabilities
- C37.09 IEEE Standard Test Procedures
- C37.010 IEEE Standard Application Guide

The successful performance and application of these vacuum circuit breakers depends as much on proper installation and maintenance as it does on good design and careful manufacture.

The instructions included in this book are necessary for safe installation, maintenance and operation and are provided to aid you in obtaining longer and economical service from your Siemens-Allis circuit breakers. For proper installation and operation—resulting in better service and lower maintenance costs—this information should be distributed to your operators and engineers.

By carefully following these instructions, difficulties should be avoided. However, they are not intended to cover all details or variations that may be encountered in connection with the installation, operation and maintenance of this equipment.

Should additional information be desired, including replacement instruction books, contact your Siemens-Allis representative.

Receiving

Type -3AF- vacuum circuit breakers are normally shipped from the factory completely assembled, inspected, tested and mounted in their respective switchgear cubicles. Immediately upon receipt of the switchgear and circuit breakers, check each item with the shipping manifest and make an examination for evidence of any damage that may have occurred during shipment.

If any shortage, damage or indication of rough handling is found, immediately call it to the attention of the local freight agent handling the shipment. Proper notation should be made by him on the freight bill. This prevents any controversy when claim is made and facilitates adjustment. Also, immediately file a damage claim with the transportation company and notify the nearest Siemens-Allis sales representative.

NOTE Damage claims must be processed within the time period specified by the carrier. Siemens-Allis cannot be held responsible for shipping damage, either external or internal, if the inspection is not made and claim forwarded within the set time limit.

In some cases, Type -3AF- vacuum circuit breakers are shipped separate from their cubicles. In those cases, check and examine upon receipt and report any problems as indicated above. Carefully remove the packaging using the correct tools. The circuit breakers may be carefully lifted using the lift holes on the upper rear side of the operator housing. See table 1 for weights. Care should be taken not to damage the insulators or circuit breaker during any lifting or moving operations.

"As Found" Tests

When the circuit breakers are received perform and record "As Found" insulation tests using megger or Doble tests to give an initial value for future comparative indication of insulation change. Contact resistance tests can also be made using a ductor. This is recommended for all new circuit breakers especially if they are to be stored for extended periods as they may absorb moisture and contaminants. This should also be done after storage and prior to placing breakers into service. Changes in values between subsequent tests should be evaluated and corrective action taken where needed.

Since wide variations can occur in insulation values and contact resistance because of atmospheric conditions, contamination and type of test equipment, discrete values cannot be given. However, making and recording these tests on new equipment, and again at regular intervals, will give a comparative indication of insulation and/or contact resistance change. Maintaining a permanent record of these values for each circuit breaker should be part of the Maintenance Program.

NOTE: Before testing, review the procedures and safety precautions indicated in the section 'High Potential Testing and Electrical Interrupter Vacuum Check', page 29.

- a. Insulation resistance test should be made to verify the insulation integrity. These can include megger or Doble tests. If possible, a high-potential test should be made for one minute at:

RATED VOLTS (MAX.)	TEST VOLTAGE	
	A.C.	D.C.
4.76 kV	14,000	20,000
8.25 kV	27,000	38,000
15.10 kV	27,000	38,000

With the breaker open, check each phase across the open contacts by connecting from the upper (27) to the lower (29) primary disconnect. With the circuit breaker closed, check phase-to-phase and each phase-to-ground.

- b. A 60HZ dielectric test on secondary and control circuits should be made at 1125 volts (1500 x 75%) for one minute.

NOTE: Certain control devices such as, charging motors, pushbuttons, bell alarms, etc., may have only a 900 volt rating. 75% of 900V would allow a field Hi-POT of only 675 volts AC.

- c. If desired, contact resistance tests can be made using a ductor.
d. Make a permanent record of all tests performed.

Storage

The circuit breakers should be reinstalled in their cubicles as soon as possible. If storage is necessary, "As Found" tests are recommended prior to and after storage for comparison. **For storage, the circuit breakers should be kept indoors in a clean dry location** where they will not be exposed to such items as dirt, construction dust, corrosive atmospheric mechanical abuse or rapid temperature variation. If stored in their cubicles, space heaters or similar heat source should be used to prevent condensation.

Outdoor storage of circuit breakers is not recommended. If breakers must be stored outdoors, they must be completely covered and protected from the elements. A heat source must be provided to prevent condensation and subsequent corrosion. Often 500 watts heat per breaker is used. Covering should allow for ventilation.

It is recommended that periodic inspections of the breakers be made during storage and if necessary, procedures adjusted to keep the breakers in proper condition.

GENERAL

Page 6

Installation Checkout

The following agenda provides a convenient check list of activities to be performed while withdrawing and preparing the circuit breaker for use prior to reinsertion into the cubicle.



The agenda may also be used for circuit breakers shipped separately from the cubicles.

	⚠ Danger
	Hazardous voltages and high speed mechanical parts will cause death or severe personal injury and property damage. Read instruction manual, observe safety instructions and use qualified personnel.

Refer to cubicle Instruction Book SG-3148 for important additional information about the cubicle.



- 1A. If breaker is shipped in the switchgear withdraw the circuit breaker from its cubicle as follows:
 - a) Confirm control power is de-energized by opening disconnect device.
 - b) Confirm the vacuum circuit breakers primary contacts are open and the stored energy closing springs are discharged, by pressing the trip (54) (red), then the close (53) (black) and then the trip pushbuttons. See Fig 3 Typical Operator Housing.
 - c) Operate screw racking mechanism to withdraw circuit breaker from "connected" to "test/disconnect" position.
 - d) Push the two thumb levers on the latch disconnects (T3) while pulling forward on the handles T1.4.1 on breaker front panel. This releases the breaker from the racking mechanism and moves it forward to the withdrawal position.
 - e) Position accessory transfer truck (or lift truck) in front of breaker cell with transfer truck's guide pins inserted into round alignment hole on each side of breaker cell and then turn handles on transfer truck to lock it to the cubicle. The guide pin insertion releases the breaker withdrawal interlock.
 - f) Pull the circuit breaker forward onto the transfer truck. Rotate the transfer truck handles into position to release it from the cubicle and lock the breaker on the transfer truck.
- 1B. If the breaker is shipped separately from the switchgear carefully remove the packaging using proper tools. Vacuum breakers are normally supplied with their primary contacts open and stored energy springs discharged. Press trip (54), close (53), and again trip push buttons to confirm this is true. See Fig 3 Front Elevation. Breaker may now be carefully moved onto the transfer truck (or lift device).
Refer to "Receiving" section for lifting alternatives.
2. Carefully note and check rating plate (51) per figure 2 to ensure maximum voltage, continuous current, interruption rating, and control voltages are compatible with the system and the cubicle into which the breaker is to be inserted.
3. Perform a careful visual inspection noting any damage which may have occurred in shipment. Clean all dust, dirt and foreign materials accumulated in shipment.
4. Using procedures described in the maintenance section of this manual, carry out a vacuum check.
5. Complete a manual spring charge, close and trip operation.
6. Reinstall any barriers removed during inspection.
7. Check primary contact assemblies. Fingers should be fully engaged, spring loaded and arranged with symmetry about the primary stud.
8. De-energize cubicle control power, and install plug jumper between cubicle secondary disconnects and those of the breaker. Upon re-energizing control power, closing springs should automatically charge. Then close and trip the circuit breaker with the local control switch.
9. Note that with the breaker closed, the racking interlock blocking arm (T5 Fig. 24) on the right side of the truck housing is raised. This interfaces with the cubicle and prevents the movement of a closed circuit breaker.
10. Perform and record results of the "As Found" tests. Compare with pre-storage "As Found" test values if stored.
11. De-energize control power and remove plug jumper. Press trip (red), then close (black) and then trip pushbuttons to confirm breaker is open and springs discharged.

12. Coat movable primary and secondary disconnects with a light film of Siemens-Allis contact lubricant, 15-171-370-002.
13. Observe location of secondary disconnect handle in cubicle (lower right side of breaker cell). Slide toward front of cell and back. Note spring detent in forward position.

	 Danger
	<p>Hazardous Voltages Associated with the application of this breaker will cause death, personal injury, and property damage.</p> <p>Before proceeding with the initial circuit breaker insertion and racking to the bus, be certain the bus is de-energized.</p>

14. Circuit breakers should be properly located and locked on transfer truck (or lift truck). Move transfer truck into position in front of breaker cell with guide pins inserted into cubicle alignment holes. Rotate handles on transfer truck to lock it to the cell. This action also rotates blocking cam and allows breakers to be rolled from transfer truck into the cell. After the breaker has been rolled into the cell, turn transfer truck handle to unlock it from the cell and move it out of the way.
15. Breaker should be inserted into cell to the Test/Disconnect position. The screw racking latches on each side of the breaker should latch over the breaker racking block (T3.7 Fig. 14) and securely hold the breaker in place.
16. Locate secondary disconnect handle just below the right side of breaker front panel. Slide handle forward until secondary disconnects are fully engaged and detents are moved over the forward angle edge.

17. Re-energize control power. Stored energy springs should automatically charge. Close and trip the breaker electrically. Observe that the breaker operates properly and the stored energy motor recharges after the close operation.

	 Warning
	<p>A fully connected breaker controls high voltage and currents. Improper use can cause death, personal injury or property damage.</p> <p>Perform initial racking to connect position on de-energized bus. If an energized bus is unavoidable obtain appropriate clearances before beginning the next two steps.</p>

18. Move breaker to fully connected position on a de-energized bus. Close and trip breaker from main control position.
19. If a lock-out key interlock position has been provided in the cubicle (5 Fig. 26) place this interlock in the breaker "Trip-Free" position, key removed, and perform a close operation. Check that the breaker has gone trip free. Open the interlock, "key held" position and repeat the closing trial. The breaker now should successfully close.
20. If a racking prevention key interlock position has been provided in the cubicle (17 Fig. 25), place this interlock in the 'Racking Blocked' position, key removed, and try to rack between positions. Open the interlock, 'key held' position, and the racking crank should slide the shield back allowing the breaker to be racked.
21. The breaker should now be ready for service.

TECHNICAL DATA

Rating Plate Content

Type	Designates circuit breaker model number and broadly identifies application in terms of maximum voltage and interruption capability.
Amps	Rated continuous current is the designated limit of current in RMS amperes at rated frequency which the breaker may be expected to carry without exceeding temperature limitations.
Rated Max Volts kV	The highest RMS voltage above nominal system voltage for which the circuit breaker is designed, and is the upper limit for operation.
Volt Range Factor (K)	The ratio of rated maximum voltage to the lower limit of the range of operating voltage in which the required symmetrical and asymmetrical interrupting capabilities vary in inverse proportion to operating voltage.
BIL kV	The rated full wave impulse withstand voltage. The crest value of a standard 1.2 x 50 impulse voltage wave which a new circuit breaker must be capable of withstanding without flashover or puncture during design tests.
Rated Short Circuit kA	The symmetrical component of short-circuit current in RMS amperes which the breaker may be expected to interrupt.
Close & Latch kA	The maximum making current into which the circuit breaker may be expected to close and latch.
Inter Time Cyc.	The maximum permissible interval between energizing the trip circuit at rated control voltage and the interruption of the main circuit in all poles.
Hz	Rated frequency is the sinusoidal periodicity at which the circuit breaker is designed to operate.

Rating Plate Content

Wiring Diagram	An elementary diagram providing detailed information regarding electrical function and wiring within the circuit breaker.
Motor (Spring Charging) Volt Range	Range of control voltages required to serve the motor which stores energy in the closing springs.
Amps Nominal	Effective value of current required at nominal control voltage when applied to the serve the motor which stores energy in the closing springs.
Close (Solenoid) Volt Range	Required range of control voltage applied to the closing solenoid which will ensure successful release of the closing springs.
Amps Nominal	The effective value of current required at nominal control voltage when applied to the spring release solenoid.
Trip (Solenoid) Volt Range	Required range of control voltage applied to the tripping (opening) solenoid which will ensure a successful tripping operation.
Amps Nominal	Effective value of current required at nominal control voltage when applied to the tripping (opening) solenoid.
Manual	Reference to the instruction manual applicable to the circuit breaker by publication number.
LBS	Weight in pounds of the complete circuit breaker assembly.
Serial No.	Specifically identifies an individual breaker and affords traceability to test records and manufacturing dates.
Date Mfg.	The month and year within which the circuit breaker was manufactured.

SIEMENS-ALLIS		Raleigh, NC
A.C. High Voltage Circuit Breaker		
TYPE _____		AMPS _____
RATED MAX VOLTS kV _____	VOLT RANGE FACTOR K _____	BIL kV _____
RATED SHORT CIRCUIT kA _____	CLOSE & LATCH kA _____	INTER TIME CYC _____
WIRING DIAGRAM _____		
Hz _____		
MOTOR _____	VOLTS RANGE _____	AMPS NOMINAL _____
CLOSE _____	VOLTS RANGE _____	AMPS NOMINAL _____
TRIP _____	VOLTS RANGE _____	AMPS NOMINAL _____
MANUAL _____		LBS. _____
SERIAL NO. _____		DATE MFG. _____
Made in USA		19-458-024-331

Figure 2
Rating Plate

TECHNICAL DATA

Rating Summary

1. Breaker Type
2. Maximum Voltage, kV
3. Continuous Current, AMPS
4. Power System Frequency, Hz
5. Rated Short Circuit Current, kA
6. Voltage Range Factor K
7. Interruption Time, Cycles 60 Hz
8. Rated Withstand Test Voltage—Low Frequency kV rms
9. Rated Withstand Test Voltage—Impulse kV crest
10. Closing and Latching Capability (C&L), kA

Breaker Type

Type -3AF- circuit breaker designations are normally arranged in the following format, with significance of each element indicated:

VV-3AF-MMMM-AAAA-CC (ex: 15-3AF-1000-1200-77)

- VV — General voltage class
- 3AF — Circuit Breaker Design
- MMMM — Nominal mVA rating
- AAAA — Continuous Current Rating
- CC — Close and Latch Capability

Table 1
Rating Summary and Weights

Type	Vmax kV	I AMPS	Freq Hz	Isc kA	K	Int T. Cycles	Withstand -kV		C&L Rating	Weights, Approximate	
							Low Freq	Impulse		Pounds	Kilograms
Number 1	2	3	4	5	6	7	8	9	10		
5-3AF-250	4.76	1200	60	29	1.24	3	19	60	58	530	240
5-3AF-250	4.76	2000	60	29	1.24	3	19	60	58	640	290
5-3AF-350	4.76	1200	60	41	1.19	3	19	60	78	530	240
5-3AF-350	4.76	2000	60	41	1.19	3	19	60	78	640	290
5-3AF-350	4.76	3000	60	41	1.19	3	19	60	78	750	340
7-3AF-500	8.25	1200	60	33	1.25	3	36	95	66	530	240
7-3AF-500	8.25	2000	60	33	1.25	3	36	95	66	640	290
7-3AF-500	8.25	3000	60	33	1.25	3	36	95	66	750	340
15-3AF-500	15.0	1200	60	18	1.30	3	36	95	37	530	240
15-3AF-500	15.0	2000	60	18	1.30	3	36	95	37	640	290
15-3AF-750	15.0	1200	60	28	1.30	3	36	95	58	530	240
15-3AF-750	15.0	2000	60	28	1.30	3	36	95	58	640	290
15-3AF-750	15.0	3000	60	28	1.30	3	36	95	58	750	340
15-3AF-1000	15.0	1200	60	37	1.30	3	36	95	77	530	240
15-3AF-1000	15.0	2000	60	37	1.30	3	36	95	77	640	290
15-3AF-1000	15.0	3000	60	37	1.30	3	36	95	77	750	340

Service Conditions

The following parameters define the usual service conditions under which the circuit breakers shall be considered suitable for operating at their standard ratings. Conditions of use beyond these limits must be given special consideration, consultation with the factory or reference to the IEEE Application Guide, ANSI C37.010.

Maximum Ambient Temperature = 40 C (104 F)

Minimum Ambient Temperature = -30 C (-22 F)

Altitude = 3300 Feet (1000 meters)

Unusual service conditions which expose the equipment to dust, steam, salt spray, corrosive gases, dripping water, vibration, shocks, high and low temperatures, high altitude and the like may require special construction. Refer concerns to the factory.

The values of insulation level compiled in Table 1 are referred to sea level in accordance with ANSI C37.04-1979 consolidated standards. The higher the site altitude, the lower the insulating capacity of the air. The decrease in insulating capacity is neglected by standards for altitudes of up to 3300ft. (1000m) above sea level. For higher altitudes, the values of low-frequency withstand voltage, impulse withstand voltage and rated continuous current must be corrected in accordance with table 1.

Table 2
Altitude Correction Factors, k

Altitude		Rated Maximum Voltage and Insulation Level	Rated Continuous Current
ft.	(m)		
3300	(1000)	1.00	1.00
5000	(1500)	0.95	0.99
10000	(3000)	0.80	0.96

NOTE: Interpolated correction factors shall be used in determining factors for intermediate altitudes.

TECHNICAL DATA

Page 10

General Performance Data

Table 3
Operating Times - Typical Values

Characteristic	Cycles 60 Hz	ms
Closing Time	4.5	75
Opening Time	2.0	33
Arcing Time at 60Hz	1	15
Interrupting Time	3	50

Table 4
Typical Closing and Tripping Solenoid Characteristics

Control Voltages ANSI C37.06 Tbl. 10	Close Coil		Trip Coil	
	Ohms	Amps	Ohms	Amps
48 VDC	23	2.1	2.4	20.0
125 VDC	121	1.0	23	5.4
250 VDC	487	0.5	121	2.1
120 VAC 60Hz	121	0.9	23	4.7
240 VAC 60 Hz	487	0.4	121	1.8

Table 5
Typical Spring Charging Motor Characteristics

Control Voltages ANSI C37.06 Tbl. 10	Current Amps	Charge Time Seconds
48 VDC	8	10
125 VDC	6	8
250 VDC	3	8
120 VAC 60Hz	6	8
240 VAC 60Hz	3	8

Table 6
Auxiliary Switch Ratings

Characteristic	Rating
Maximum Operating Voltage	500 V
Continuous Current, Max.	10 A
Making Current, Max.	30 A
Breaking Capacity	
Resistive Load DC or AC	1200 VA
Inductive Load at 220VDC (L/R = 20ms)	750 VA

www.ElectricalPart.com

INTERRUPTER/OPERATOR

Description

Page 11

Description—General

The type 3AF breakers are of drawout construction, and conform to the requirements of ANSI C37.20 for breakers to be applied in metal clad switchgear. The three vacuum interrupters, primary insulators, and operating mechanism comprise a unitized "interrupter/operator" sub-assembly (Figure 4) fitted to a supporting drawout "Truck" sub-assembly, (Figure 24). This drawout truck provides: secondary disconnects; closed breaker racking interlocks, closing spring discharge feature, and other requirements needed to ensure safe and reliable use during racking and fully connected operations.

The ensuing descriptive material will discuss the vacuum **interrupter/operator** mechanism sub-assembly in detail and then go on to treat the drawout 'Truck' sub-assembly and its important interlocking features.

Description and Operation

The interrupter/operator mechanism sub-assembly consists of the three breaker poles, each with its vacuum interrupter, mounted on the common motor or hand charged spring stored energy operating mechanism housing. This sub-assembly is shown in figures 3 & 4.

Construction

The construction characteristic of all vacuum circuit breakers can be seen in Figs. 3 thru 7. The circuit breaker poles are each fixed to the rear of the operating mechanism housing, (60), by two cast-resin insulators (16). The insulators also connect to the upper (20) and lower (40) pole supports which in turn support the ends of the vacuum interrupter (30). Where required by dielectric requirements, assemblies are fitted with phase barriers (80).

The pole supports are aluminum castings on all circuit breaker ratings, except for 3000A continuous current where copper castings are used and on the 15-3AF-500, 1200A where formed steel pole supports are used.

The pole support terminals, (27) and (29) each receive primary stud extensions.

Legend Figure 3

- 50.1 Opening For Hand Crank
- 51 Rating Plate
- 53 Close Pushbutton
- 54 Trip Pushbutton
- 55 'Spring Charged' Indicator
- 58 'Open-Close' Indicator
- 59 Operation Counter
- 60 Mechanism Housing
- T1.4.1 Cover Handle
- T3 Latch Disconnect

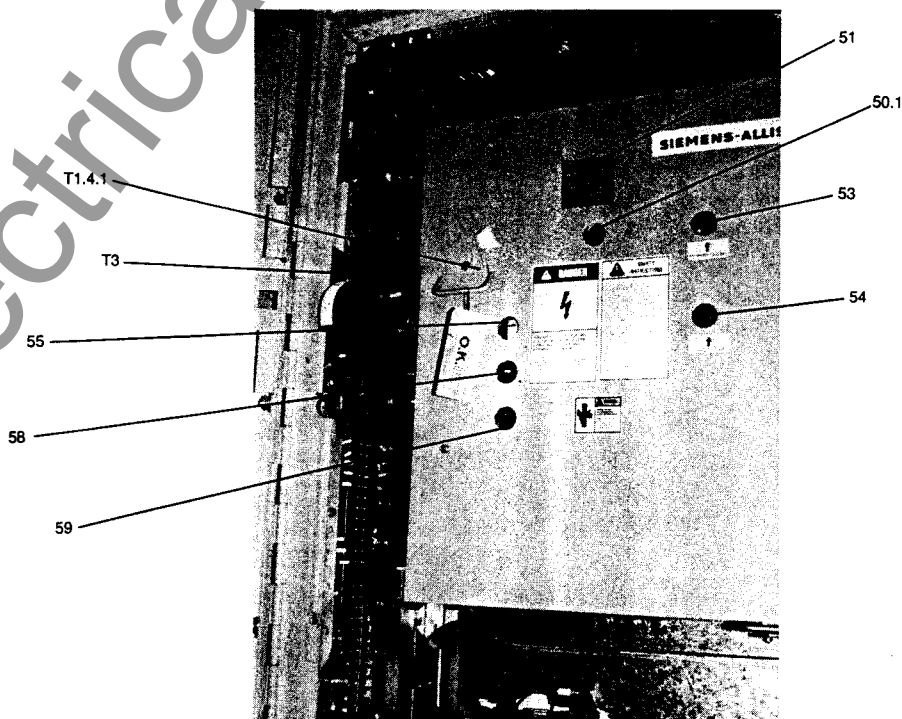

Typical Operator Housing
Figure 3

INTERRUPTER/OPERATOR

Description

Page 12

The energy-storing mechanism and all the control and actuating devices are installed in the mechanism housing. The mechanism is of the spring charged stored energy type and is mechanically and electrically trip free.

The close-open indicator (58) closing spring charge indicator 55, and the operation counter (59) are fitted on the front of the mechanism housing. (Fig. 8)

The control connector (68.7) for the control and signaling cables is a 64 contact plug or 24 point terminal block applied internally to the drawout unit. (Fig. 8)

Legend Figure 4

14	Cross-Arm	30	Vacuum Interrupter
16	Post Insulator	40	Lower Pole Support
20	Upper Pole Support	48	Insulated Coupler
27	Upper Terminal	49	Contact Pressure Spring
28	Strut	50.1	Opening for Hand Crank
29	Lower Terminal	60	Mechanism Housing

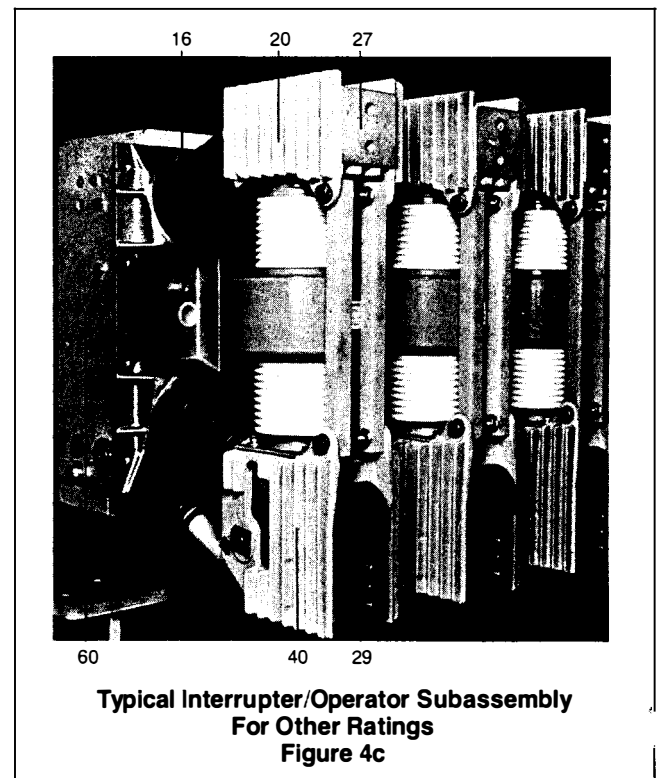
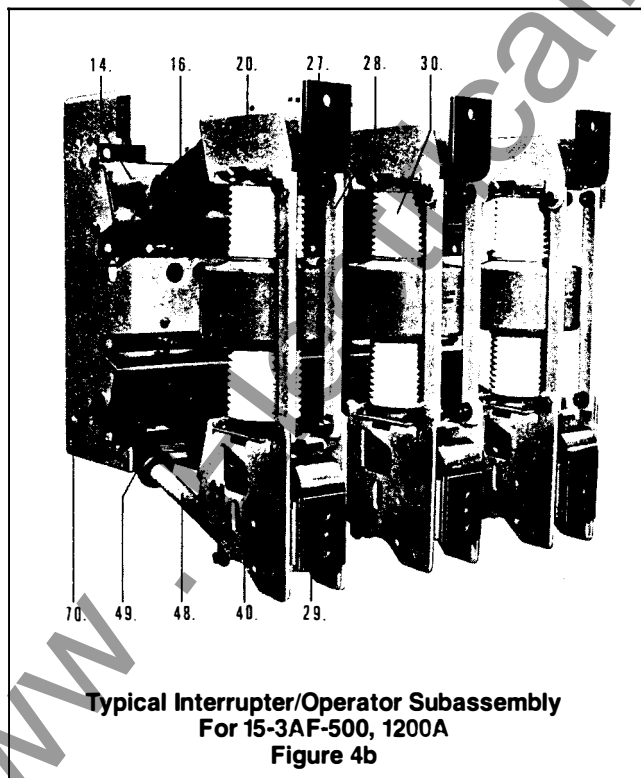
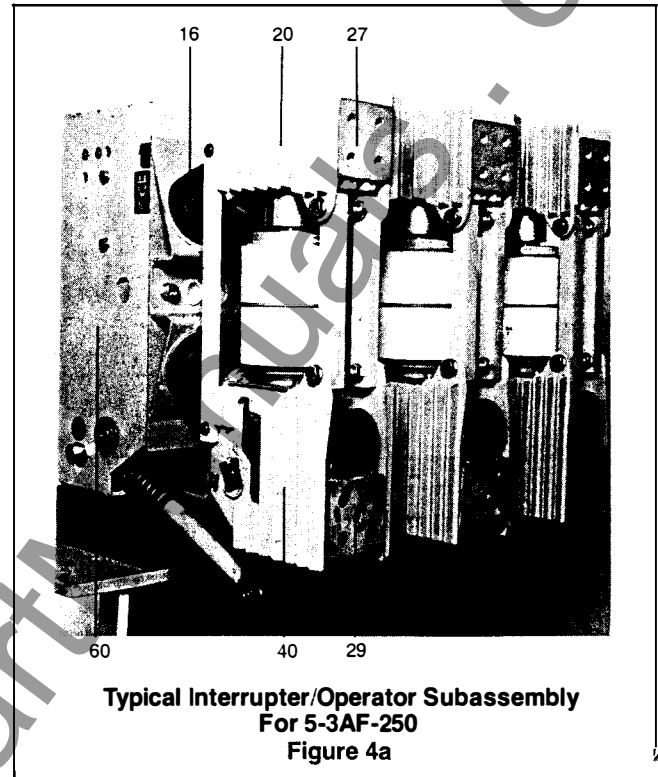

INTERRUPTER/OPERATOR

Description

Descriptions Cont.

Breaker Pole

The vacuum interrupter (30) is rigidly connected to the upper pole support (20) by its terminal post (31.2). The lower part of the interrupter is stabilized against lateral forces by a centering ring (28.1) on pole support (40). The external forces due to switching operations and the contact pressure are absorbed by the struts (28).

Current-Path Assembly

The current-path assembly consists of the upper terminal angle, (27.1) and pole support, (20), the stationary contact, (31) and the moving contact, (36), which is connected with the lower terminal, (29), by terminal clamp, (29.2), and a flexible shunt, (29.1).

Vacuum Interrupter

The moving contacts, (36), motion is aligned and stabilized by guide bushing, (35). The metal bellows, (34), follows the travel of contact, (36), and seals the interrupter against the surrounding atmosphere.

Arc-Quenching Principle

When the contacts separate, the current to be interrupted initiates an ionized metal vapor arc discharge and flows through this plasma until the next current zero. The arc is then extinguished and the conductive metal vapor condenses on the metal surfaces of the arcing chamber, (33), (Fig. 7) within a matter of microseconds. As a result, the dielectric strength in the increasing contact gap builds up very rapidly.

Below a limit of about 10,000 amperes, the arc is distributed across the contacts and the arc is easily interrupted. At currents larger than about 10,000 amperes the arcs own electromagnetic forces cause the arc to contract to essentially a point arc. If the contracted arc is allowed to remain stationary, it overheats the contacts at the arc roots to the point where the molten metal vapor does not allow the dielectric to rebuild during the current zero and large magnitude currents could not be interrupted.

The contacts are designed so that a self-generated field causes the arc to travel around the contacts. This prevents local overheating while interrupting large magnitudes of short circuit current.

The ionized metal vapor arc discharge can only be maintained if a certain minimum current flows. A current that does not maintain this level may be extinguished abruptly prior to current zero. This chopping current

must be kept to a minimum in order to prevent unduly high overvoltages building up when inductive circuits are switched. The use of a special contact material ensures that current chopping is limited to 4-5 Amp.

The rapid build-up of the dielectric strength in the break enables the arc to be safely extinguished even if contact separation occurs immediately prior to current zero.

The arc drawn in the vacuum breaker is not cooled. The metal vapor plasma is highly conductive and the resulting arc voltage only attains values between 20-200 V. For this reason and because of the short arcing times, the arc energy developed in the break is very small. This also accounts for the long electrical life expectancy of the vacuum interrupter.

Owing to the high vacuum (less than 10^{-9} bar) in the interrupter, contact clearances in the range of 6 to 11 mm (0.25 to 0.43 inches) are adequate to attain a high dielectric strength.

Switching Operation

When a closing command is initiated the closing spring, which was previously charged by hand or by the motor, actuates the moving contact, (36), through breaker shaft, (63), lever, (63.7), insulated coupler, (48), and lever, (48.6).

The forces that occur when the action of the insulated coupler is converted into the vertical action of the moving contact are absorbed by guide link, (48.9), which pivots on pole support, (40), and eyebolt, (36.3).

During closing, the tripping spring and the contact pressure springs, (49), are charged and latched by pawl, (64.2).

The closing spring of motor-operated breaker is recharged immediately after closing.

In the closed state, the necessary contact pressure is maintained by the contact pressure spring and the atmospheric pressure. The contact pressure spring automatically compensates for arc erosion, which is very small.

When a tripping command is given, the energy stored in the tripping and contact pressure springs is released by pawl, (64.2). The opening sequence is similar to the closing sequence. The residual force of the tripping spring arrests the moving contact, (36), in the open position.

INTERRUPTER/OPERATOR Description

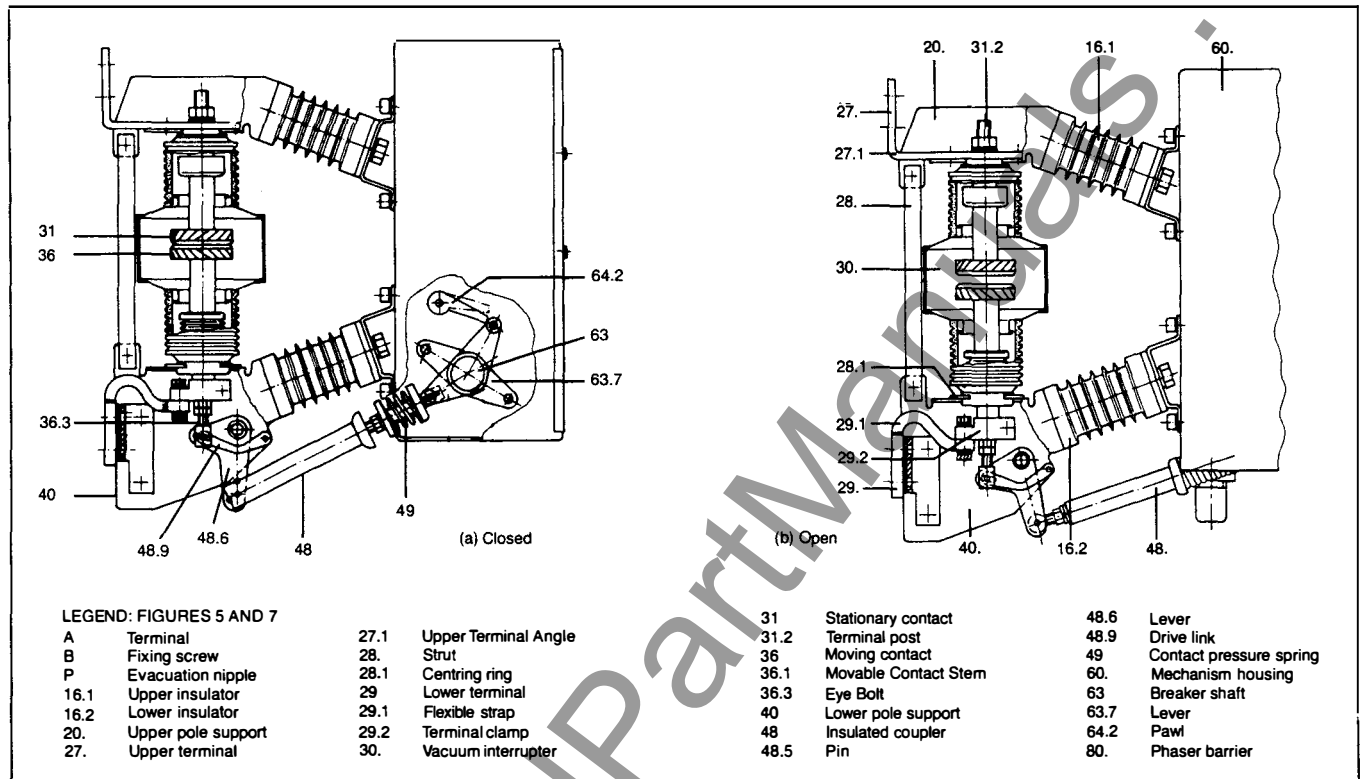

Figure 5
Section Through A Vacuum Breaker Pole

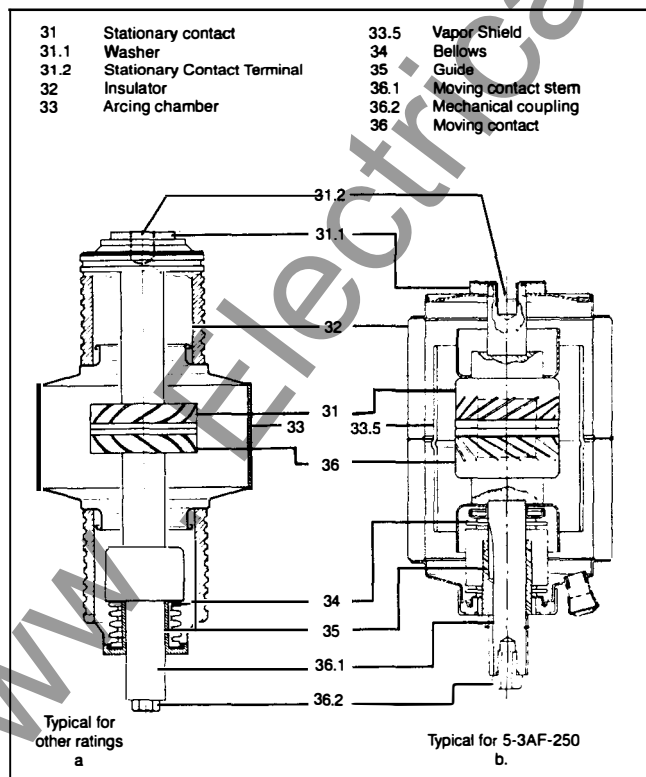

Figure 6
Section Through A Typical Vacuum Interrupter

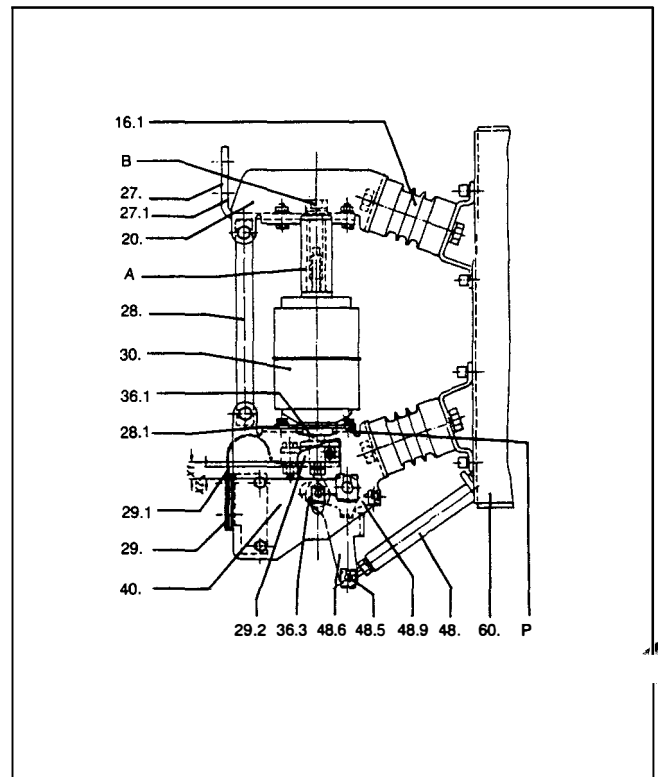

Figure 7
Section Through the Typical Vacuum Breakers

INTERRUPTER/OPERATOR

Description

Operating Mechanism (Figures 8 thru 12)

The operating mechanism is comprised of the mechanical and electrical components required to:

Charge the closing springs with sufficient potential energy to close the breaker and to store opening energy in the tripping and contact pressure springs.

Mechanisms to release closing and tripping actions.

Means of transmitting force and motion to each of three pole positions.

Operate all these functions automatically thru electrical charging motor, cutout switches, anti-pumping relay, release solenoids, and auxiliary switches.

Signal thru indicators the breaker status, (open, closed), spring condition (charged or discharged)

and number of operations.

Construction

The essential parts of the operating mechanism are shown in Fig. 8. Its actuation is described under "Flow Chart of Operating Mechanism" on page

Indirect Releases (Tripping Coils)

The shunt releases convert the electrical tripping pulse into mechanical energy, it's function being to release the tripping spring. The undervoltage release may be manually actuated by a make or a break contact. In the make contact case, its coil is shorted out, built-in series resistors limiting the current.

Motor Operating Mechanism

The spring charging motor (50.4) is bolted to the charging mechanism gear box installed in the mechanism housing. Neither the charging mechanism nor the motor require any servicing.

Auxiliary Switch

The auxiliary switch (68) is actuated by the breaker shaft.

Mode of Operation

The operating mechanism is of the stored-energy trip free type, i.e. the charging of the spring is not automatically followed by the contacts changing position, and the closing function may be overridden by a trip command at any time.

When the stored-energy mechanism has been charged, the instant of operation can be chosen as desired.

The mechanical energy for carrying out an "open-close-open" sequence for auto-reclosing duty is stored in the closing and tripping springs.

Charging

The details of the closing spring charging mechanism are shown in figures 8, 9, 10, & 12. The charging shaft, (62.1), is supported in the charging mechanism, (50.2), but is not coupled mechanically with the charging mechanism. Fitted to it are the crank, (62.2), at one end and the cam, (62.3), together with lever, (62.5), at the other.

When the charging mechanism is actuated by hand or by a motor, (50.4) the flange, (50.3), turns until the driver, (50.3.1), locates in the cutaway part of cam disc, (62.3), thus causing the charging shaft to follow. The crank, 62.2, charges the closing spring (62). When this has been fully charged the crank actuates the linkage, (55.1), via control lever (55.2) for the "closing spring charged" indicator, (55), and the limit switches, (50.4.1), for interrupting the motor supply. At the same time, the lever (62.5) at the other end of the charging shaft is securely locked by the latching pawl. When the closing

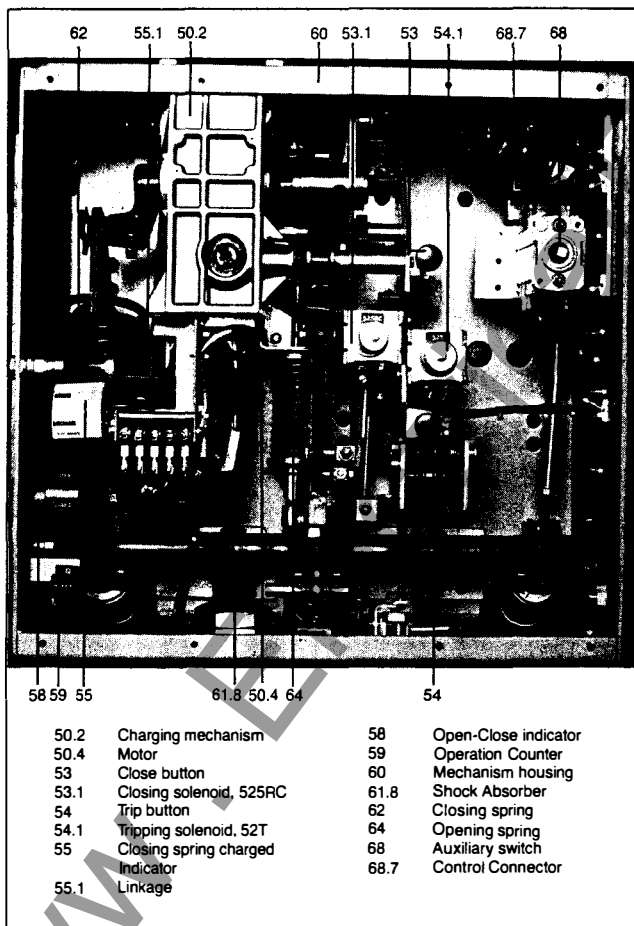

Figure 8
Operating Mechanism
Closed Position—Closing Spring Discharged

INTERRUPTER/OPERATOR

Description

Page 16

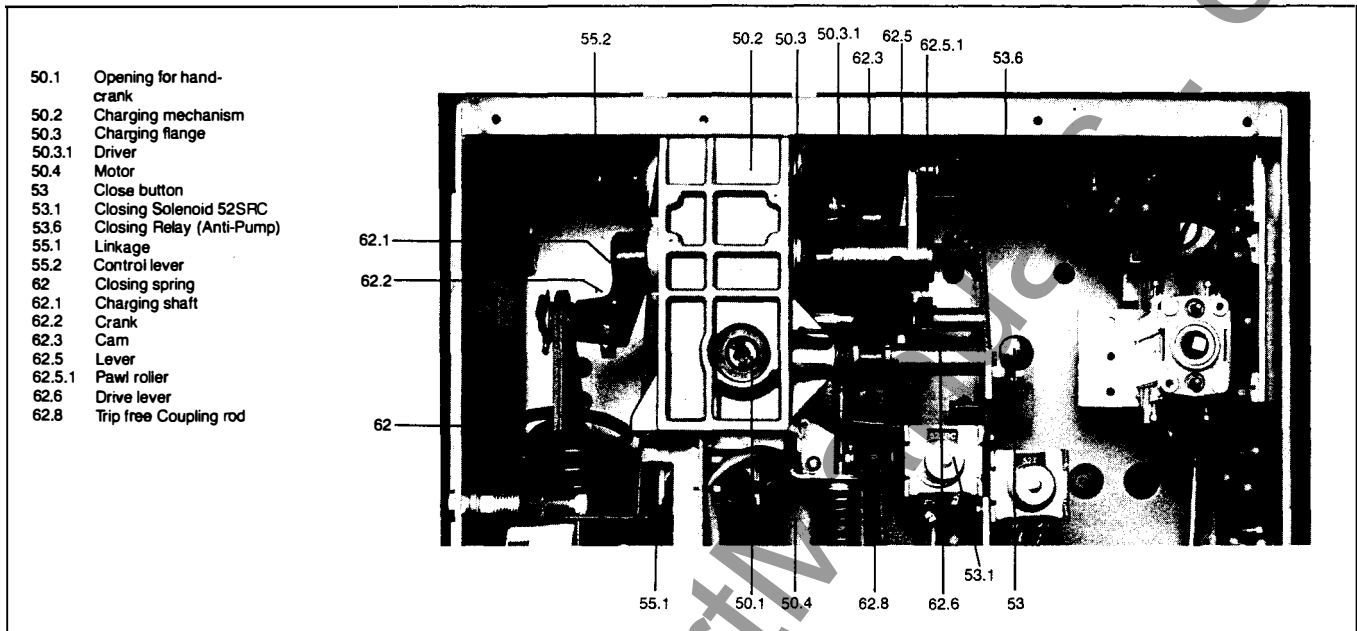

Figure 9
Details of Closing Spring Charging Components—Closing Spring Discharged

spring is being charged, cam disc, (62.3), follows idly, i.e. it is brought into position for closing.

Closing (See Fig. 8, 9, 10 and 12).

If the breaker is to be closed locally, the spring is released by pressing Close button, (53). In the case of remote control the closing solenoid 52SRC, (53.1), unlatches the closing spring.

As the closing spring discharges, the charging shaft, (62.1), is turned by crank, (62.2). The cam disc, (62.3), at the other end of the charging shaft actuates the drive lever, (62.6), with the result that breaker shaft, (63), is turned by lever, (63.5), via the trip free coupling rod, (62.8). At the same time, the lever, (63.1), (63.5) and (63.7) fixed on the breaker shaft operate the three insulated couplers for the breaker poles. Lever, (63.7), changes the open-close indicator over to open. Lever, (63.5), charges the tripping spring, (64), during closing, and the breaker is latched in the closed position by lever, (64.3), with pawl roller, (64.3.1), and by pawl, (64.2) Lever, (63.1), actuates the auxiliary switch, (68), through the linkage, (68.1).

The crank, (62.2), on the charging shaft moves the linkage, (55.1), by acting on the control lever, (55.2). The "Closing spring charged" indication is thus cancelled and, the limit switches, (50.4.1), switch in the control supply to cause the closing spring to recharge immediately.

Trip Free Operation

The trip free coupling rod, (62.8) permits the immediate decoupling of the drive lever (62.6) and breaker shaft,

(63) to override closing action by trip command or by means of the racking interlocks.

The trip free coupling rod (62.8) forms a link between the drive lever (62.6) and breaker shaft (63). The rigidity of this link depends upon a spring return latch (62.8.1) carried within the coupling rod. The spring return latch is pivotable within the coupling rod and is normally positioned to ensure the couplers rigidity. Link (62.8.2) and trip free coupling lever (62.8.3) cause the spring return latch position to be dependent upon the breaker's normal tripping components and the breaker's racking interlock. Thus, whenever a trip command is applied or the breaker is not in the fully "connected" or test position, the trip free coupling rod is no longer rigid, effectively decoupling the drive lever and breaker shaft. Under these conditions the breaker main contacts can not be closed.

Opening

If the breaker is to be tripped locally, the tripping spring (64) is released by pressing the trip button, (54). In the case of an electrical command being given, the tripping solenoid 52T, (54.1) unlatches the tripping spring (64).

The tripping spring turns the breaker shaft, (63), via lever, (63.5), the sequence being similar to that for closing.

Rapid Auto-Reclosing

Since the closing spring is automatically recharged by the motor operating mechanism when the breaker has closed the operating mechanism is capable of an open-close-open duty cycle as required for rapid auto-reclosing.

INTERRUPTER/OPERATOR

Description

Manual Operation

Electrically operated vacuum breakers can be operated manually if the control supply should fail.

Manually Charging the Closing Spring (Fig. 12)

Insert the hand-crank, (50), in hole, 50.1, and turn it clockwise until the indicator, (55), shows Closing spring "CHARGED".

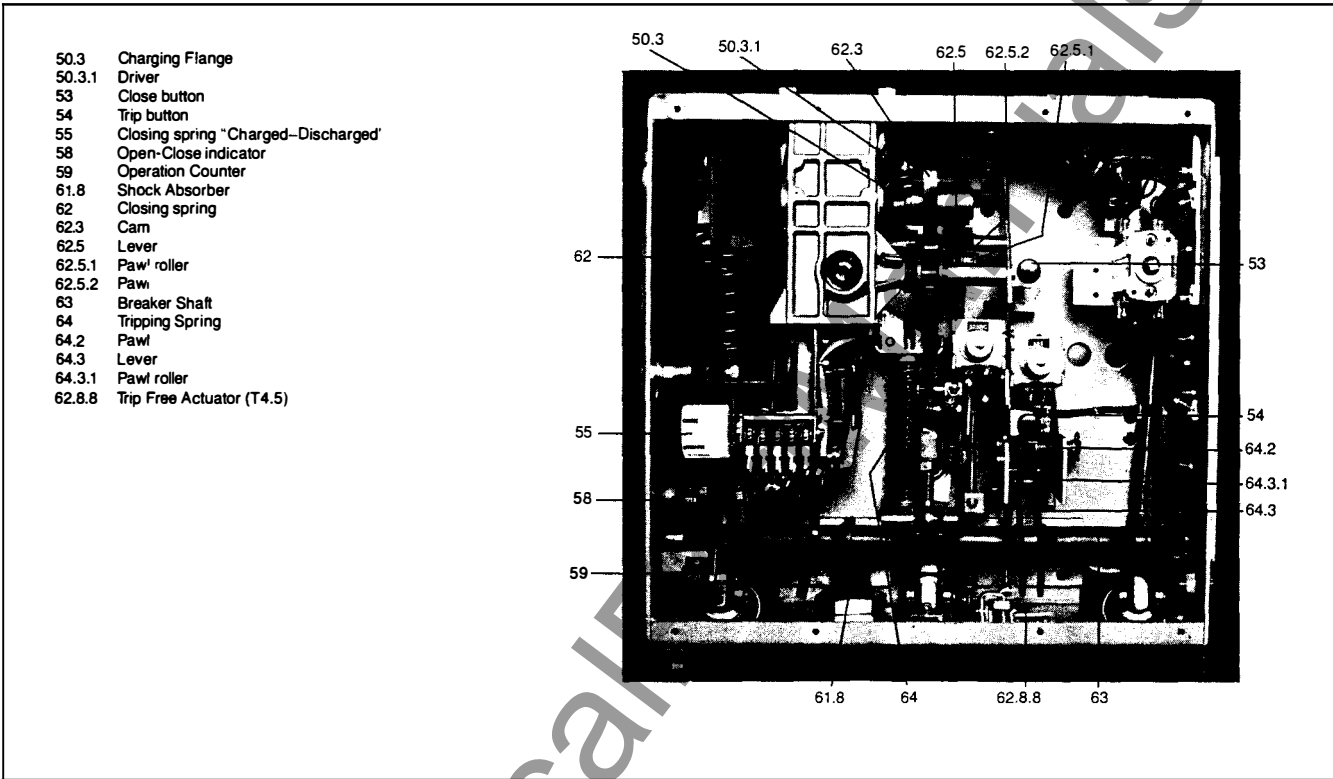

Figure 10
Operating Mechanism Open Position—Closing Spring Charged

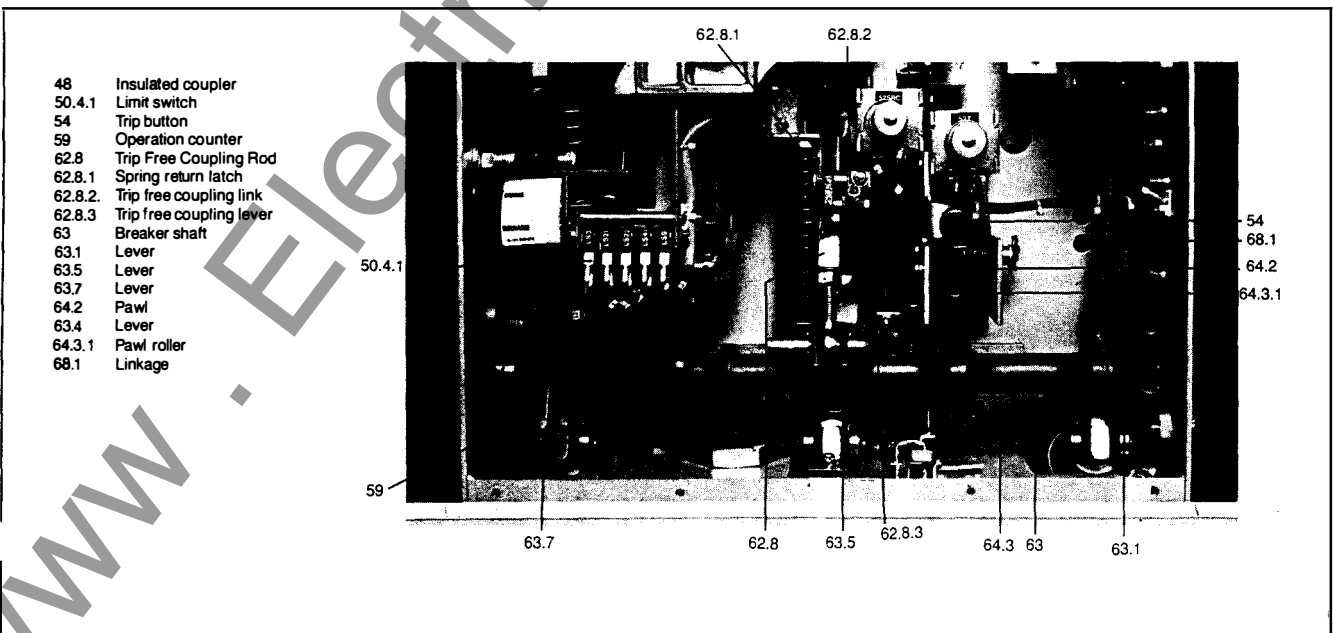

Figure 11
Breaker Shaft in Open Position—Closing Springs Discharged

INTERRUPTER/OPERATOR

Description

Page 18

Legend Figures 12A-D
 48 Insulated coupler
 53 Close pushbutton
 53.1 Closing solenoid, 52SRC
 53.2 Spring release latch
 54 Trip pushbutton
 54.1 Tripping Solenoid, 52T

62 Closing spring
 62.1 Charging shaft
 62.2 Crank
 62.2.2 Spring mounting
 62.3 Cam
 62.5 Lever
 62.6 Drive Lever

62.8 Trip free coupling
 62.8.1 Spring return latch
 62.8.2 Trip free link
 62.8.3 Trip free lever
 62.8.5 Push rod and cam assembly
 62.8.6 Interlock lever-push rod
 62.8.7 Interlock lever-actuator
 62.8.8 Trip free actuator (T4.5)

63 Breaker Shaft
 63.1 Lever-phase C
 63.5 Lever-phase B
 63.7 Lever-phase A
 64 Tripping spring
 64.2 Pawl
 64.2.1 Trip latch pin
 64.3 Lever
 64.5 Shaft

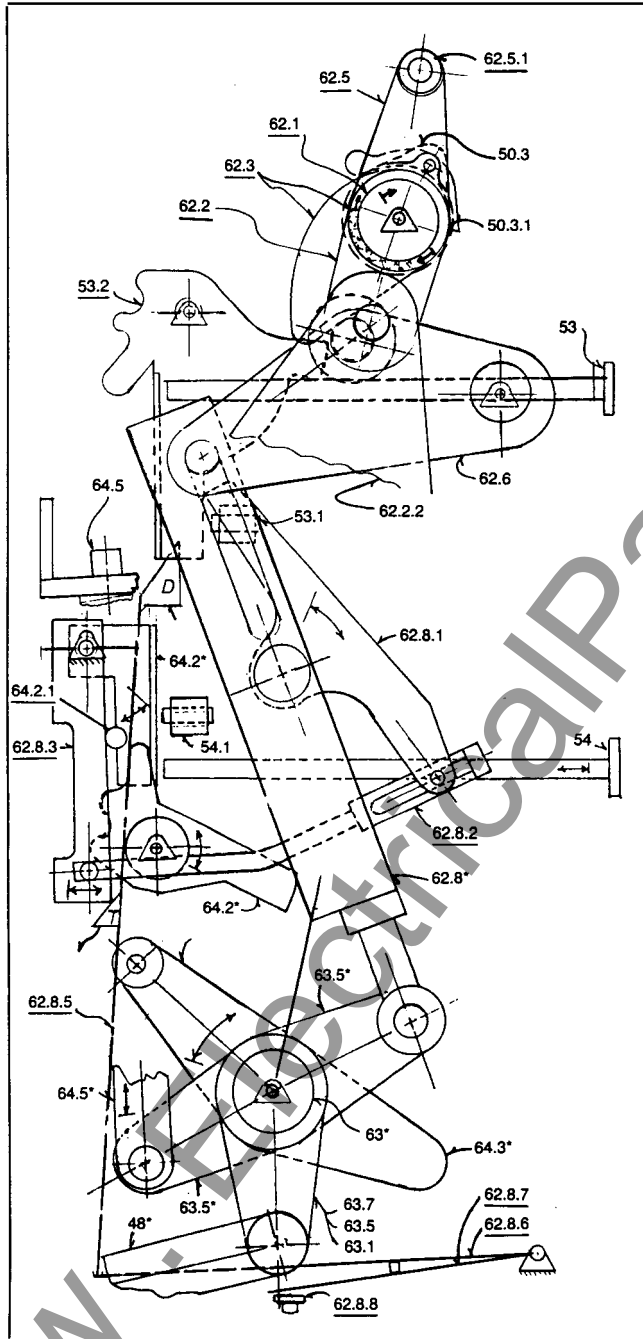

Figure 12a

Operating Mechanism Section Diagram
 Operating Mechanism Open, Closing Springs Discharged

(Starred items changed from
 12c on 'Trip' Operation) (Underlined items changed
 from 12b on 'Closing Spring Discharge' Operation)

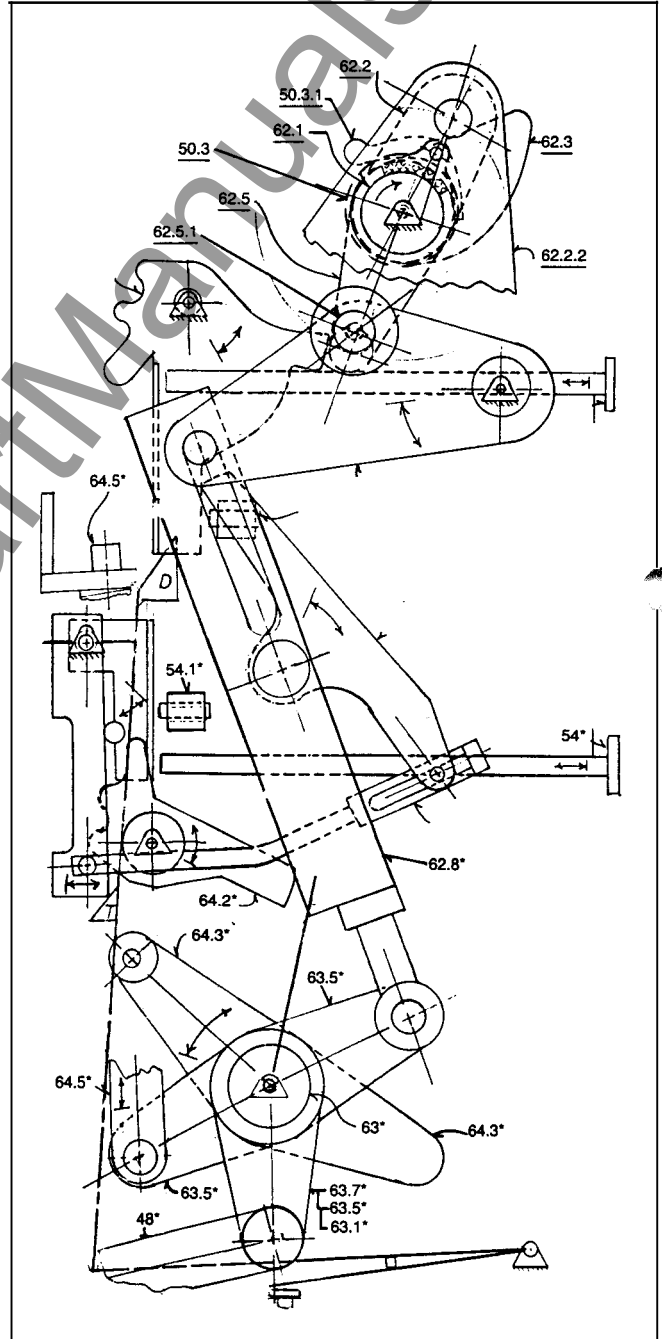

Figure 12b

Operating Mechanism Section Diagram
 Operating Mechanism Open, Closing Springs Charged

(Starred Items Changed From
 12d on 'Trip' Operation) (Underlined items changed
 from 12a on 'Closing Spring Charge' Operation)

INTERRUPTER/OPERATOR

Description

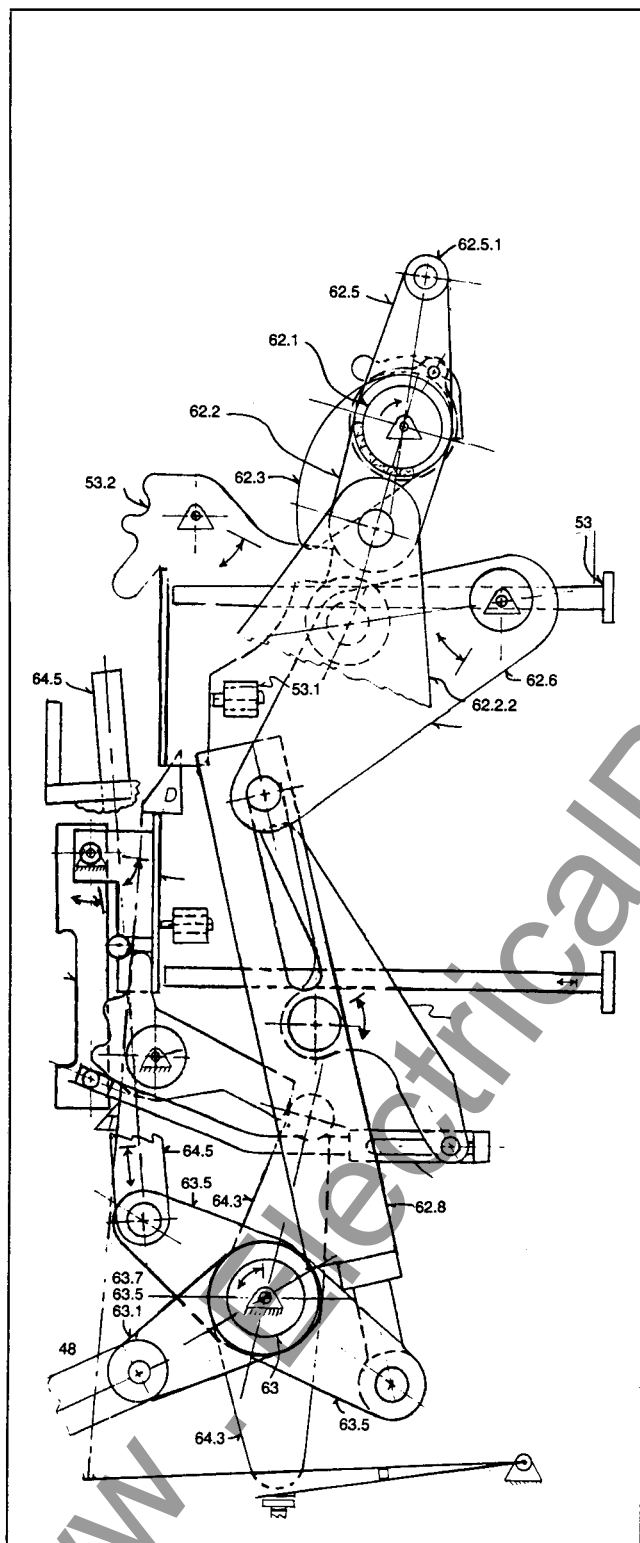

Figure 12c

Operating Mechanism Section Diagram
Mechanism Closed, Closing Springs Discharged

Callout items changed from 12b on
'Breaker Close' Operation

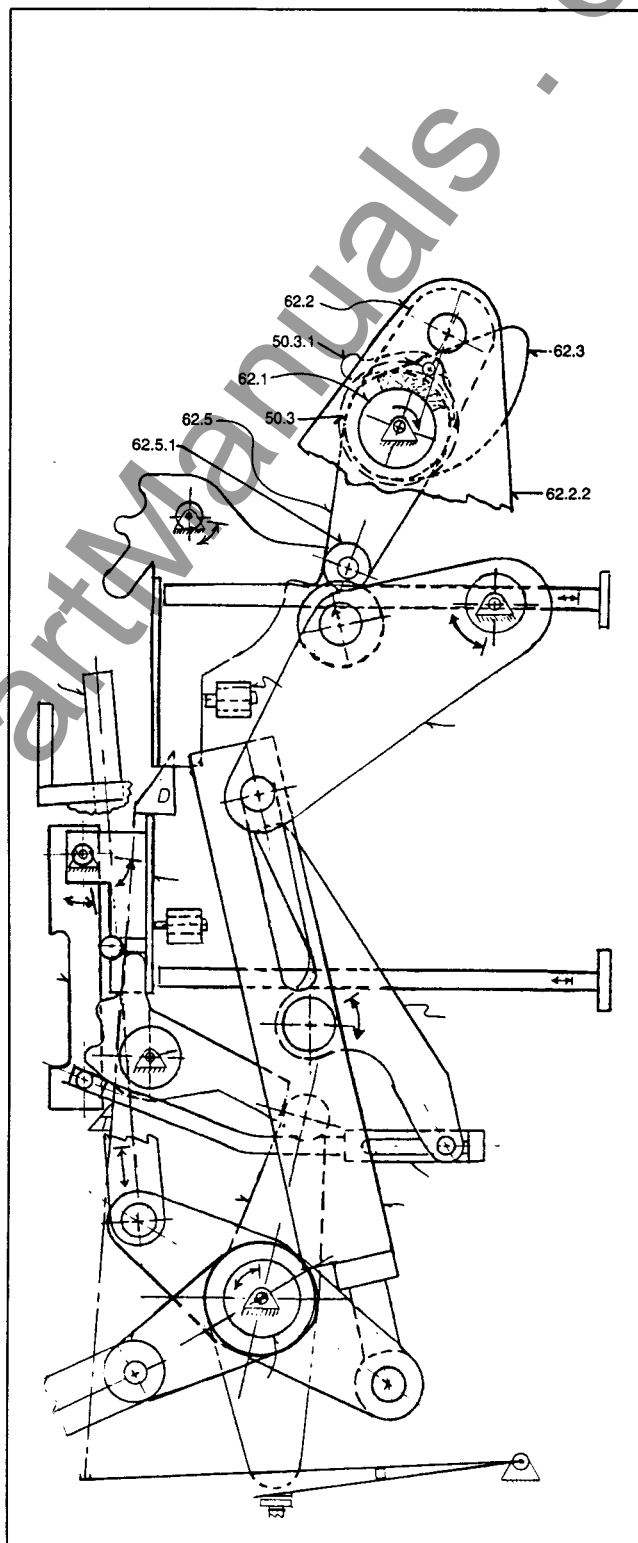

Figure 12d

Operating Mechanism Section Diagram
Operating Mechanism Closed, Closing Springs Charged

Callout items changed from 12c on
'Closing Spring Charge' Operation

INTERRUPTER/OPERATOR Description

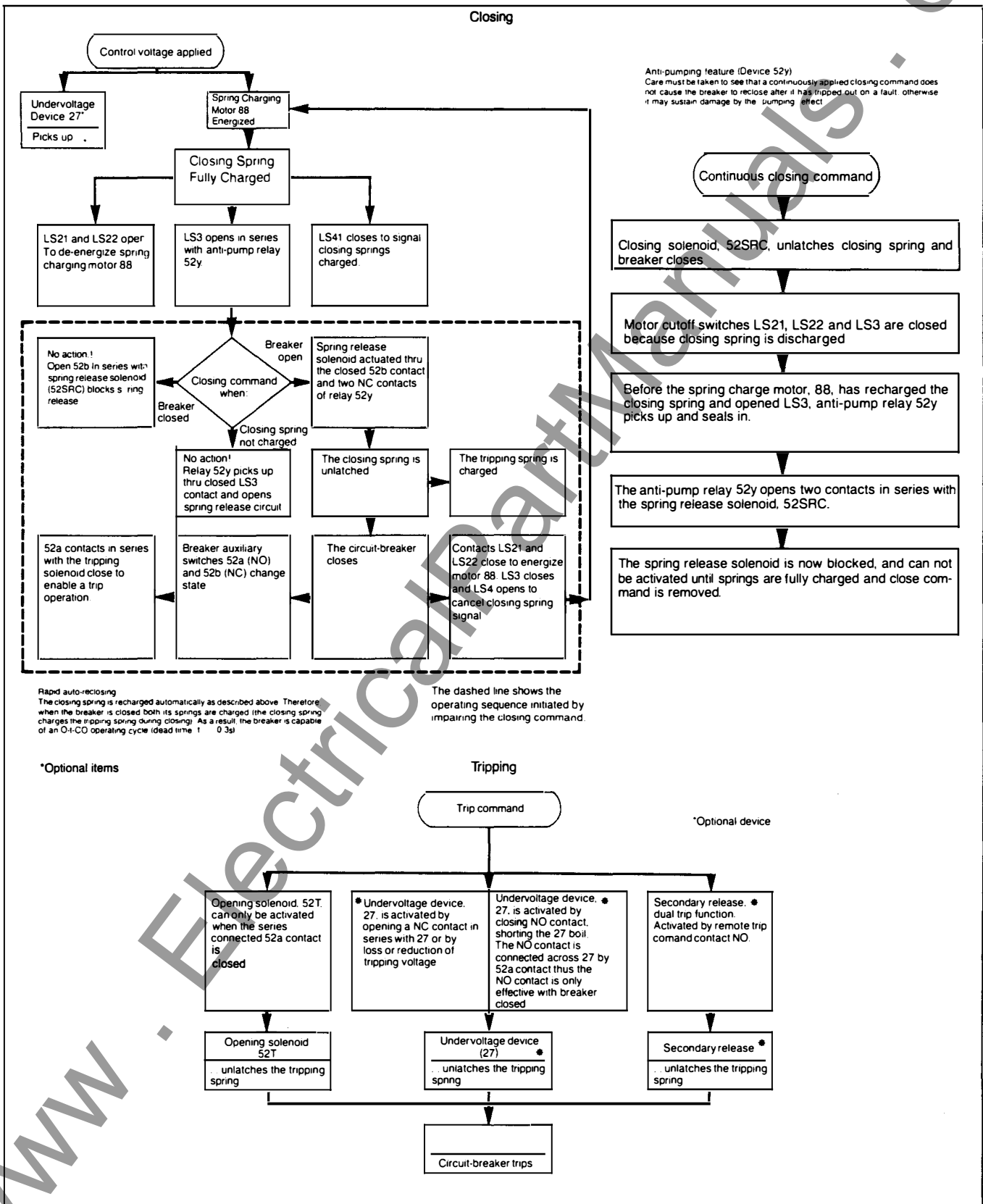

Figure 13 Operator Sequential Operation Diagram

INTERRUPTER/OPERATOR

Description

Manual Closing

Press the close button, (53), or energize the electrical closing circuit until the circuit breaker has closed. The closed-open indicator, (58), will then display the symbol "CLOSED" and the closing spring condition indicator will now read "DISCHARGED".

The closing spring is normally automatically recharged by the motor mechanism immediately after the breaker has closed.

Manual Opening

The tripping spring is charged during closing. To open the breaker, press the trip button, (54), or energize the electrical tripping circuit until the vacuum breaker has tripped and "open" is displayed by indicator, (58).

Elementary Diagram

A typical elementary diagram is shown in Figure 15 for DC close and trip control power. Optional auxiliary switches are shown.

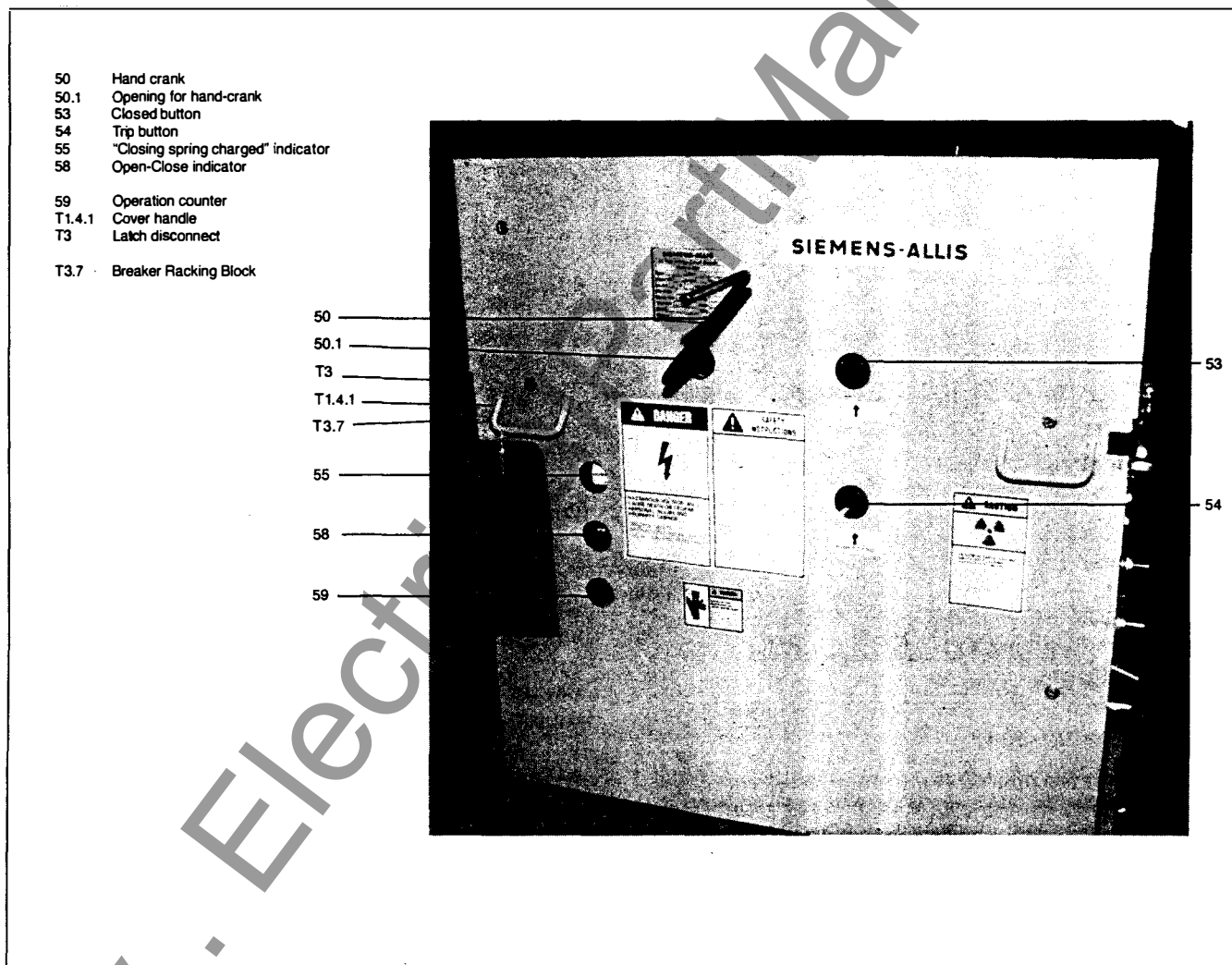

Figure 14
Front View of Mechanism Enclosure Arranged for Manual Operation

INTERRUPTER/OPERATOR

Description

Page 22

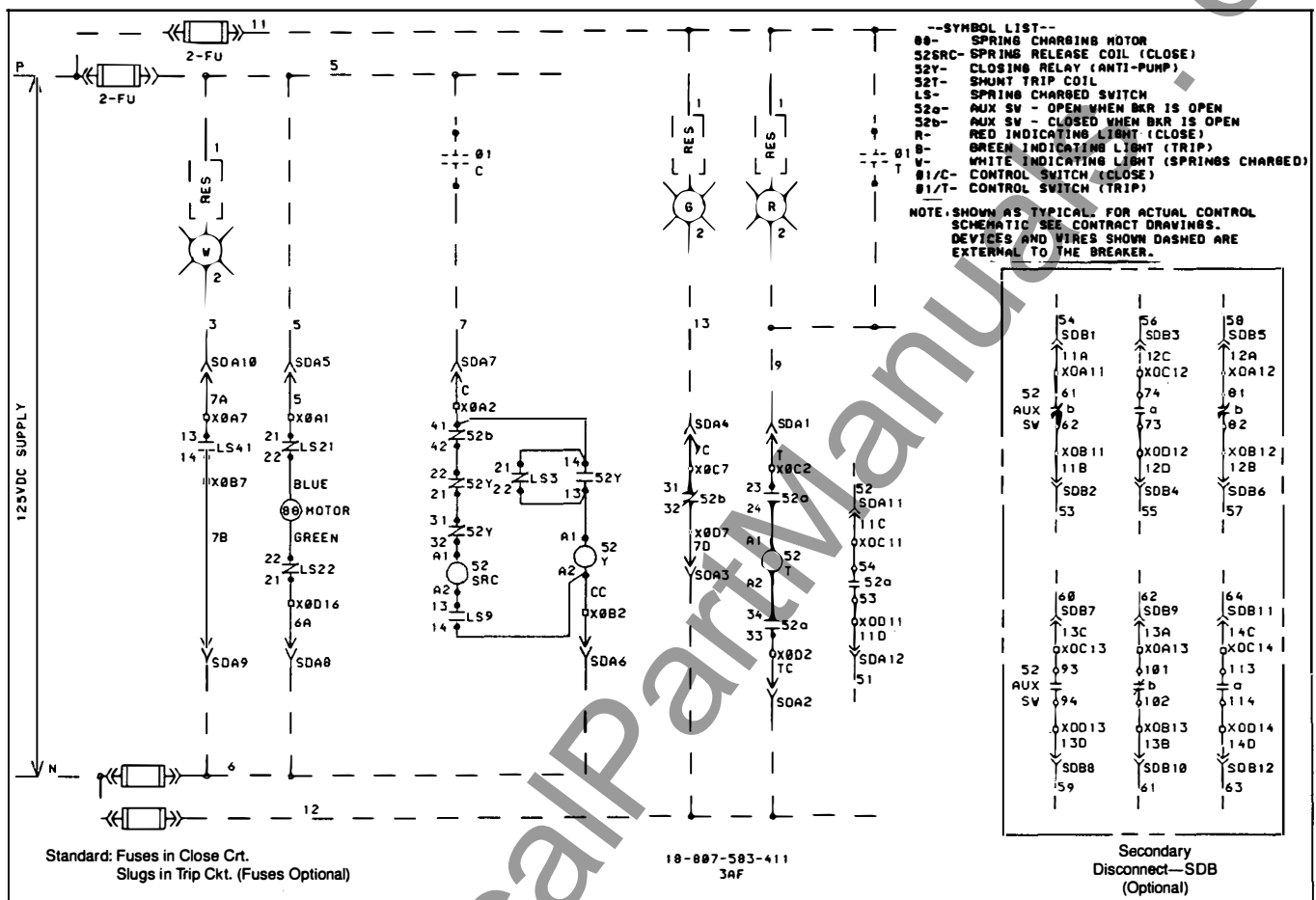

Figure 15
Typical Elementary Diagram

Indirect Releases (Dual Trip and Undervoltage)

Refer to Figures 16 and 17

The indirect release provides for the conversion of modest control signals into powerful mechanical energy impulses. It is primarily used to trip high voltage circuit breakers while functioning as a secondary (dual trip) release or undervoltage release device.

These releases are mechanical energy storage devices. Their internal springs are charged as a consequence of the breakers mechanism operating, and are released upon application or removal of applicable control voltages.

Shunt Release

Shunt releases of type 3AX1101 are used for the automatic or manual tripping of the circuit breaker by suitable protective relays or manual control devices when more than one is required. They are generally intended for connection to a separate auxiliary supply (DC or AC).

Undervoltage Release

The undervoltage release is used for continuous monitoring of the tripping supply voltage. If this supply voltage falls excessively, the undervoltage release will provide for automatic tripping of the breaker.

The undervoltage device may be used for manual or relay tripping by employing a contact in series with undervoltage device holding coil. Relay tripping may also be achieved by employing a normally open contact in parallel with the holding coil. A resistor must be provided to limit current when the normally open contact is closed.

INTERRUPTER/OPERATOR

Description

Construction and Mode of Operation

The release consists of a spring-power storing mechanism, a latching device and an electromagnet. These elements are accommodated side by side in a housing, (3) (fig. 16) with a detachable cover and three through holes, (5), for mounting screws. The supply leads for the trip coil are connected to a terminal block, (33). Two lugs, (17), are fitted beside the tripping pin, (15), for the attachment of a manual tripping lever.

The energy-storing mechanism consists of the striker pin, (23), and its operating spring, (31), which is mostly located inside the striker pin (23). When the spring is compressed, the striker pin is held by a latch, (25), whose sloping face is forced against the appropriately shaped striker pin, (23), by spring, (27). The other end of the latch, (25), is supported by a partly milled locking pin, (21) (fig. 17a), pivoted in the cover sheets of the magnet armature, (9). The armature, (9), is pivoted in front of the poles of the U-shaped magnet core, (1), and is pulled away from it by the tension spring, (11).

If the magnet coil of the shunt release is energized by the tripping impulses or if the tripping pin, (15), is mechanically actuated, magnet armature, (9), is swung against the pole faces. When this happens, the latch, (25), loses its support and releases the striker pin, (23), which is forced out by the spring, (31).

On the undervoltage release the latch, (25), is held by the locking pin, (21), as long as the armature, (9), is attracted, (Fig. 17b). If the circuit of the trip coil, (7), is

interrupted, the armature, 9, drops off, thus causing the latch, (25), to lose its support and release the striker pin, (23).

Following every tripping operation the striker pin, (23), must be reset to its normal position by loading the spring, (31). This takes place automatically via the operating mechanism of the circuit breaker.

Since the striker pin of the undervoltage release is latched only when the armature is attracted, this trip is fitted with a screw, (29) (Fig. 17c), for locking the striker pin, (23), in the normal position for adjusting purposes or for carrying out trial operations during breaker servicing.

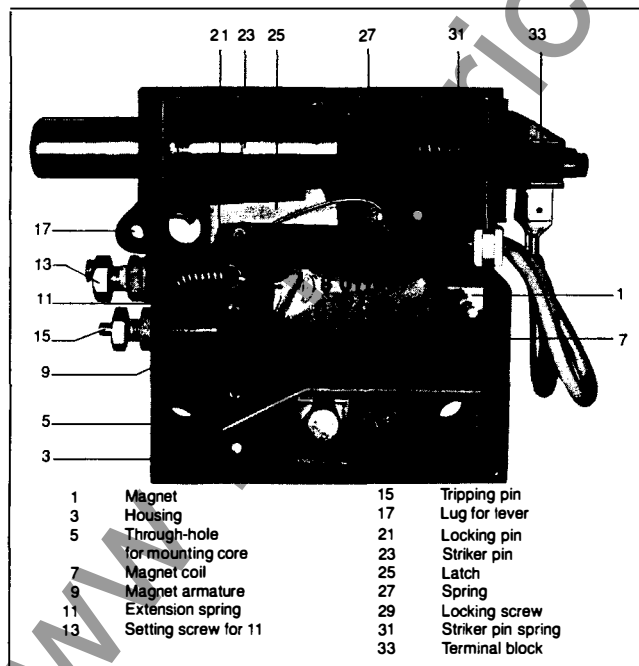

Figure 16
Construction of Shunt Release
(Shown Released)

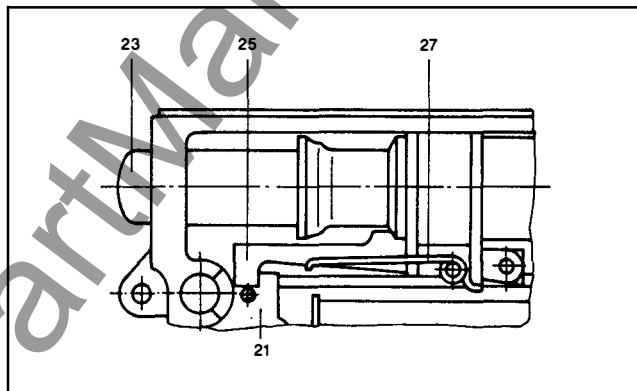

Figure 17a Latch Detail Shunt Release
(Shown Charged)

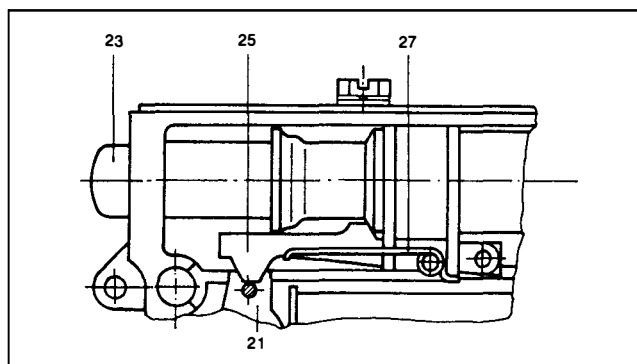

Figure 17b Latch Detail Undervoltage Release
(Shown Charged)

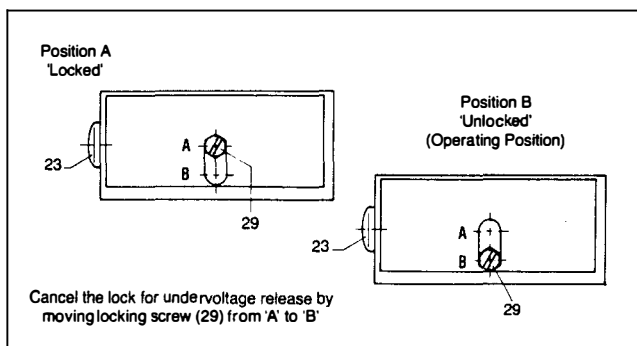

Figure 17c Undervoltage Blocking Feature

INTERRUPTER/OPERATOR Maintenance

Page 24

General

Thorough, periodic inspection is important to satisfactory operation. Inspection and maintenance frequency depends on installation, site, weather and atmospheric conditions, experience of operating personnel and special operation requirements. Because of this, a well-planned and effective maintenance program depends largely on experience and practice.

FAILURE TO PROPERLY MAINTAIN THE EQUIPMENT CAN RESULT IN SEVERE PERSONAL INJURY AND PRODUCT FAILURE. THE INSTRUCTIONS CONTAINED HEREIN SHOULD BE CAREFULLY REVIEWED, UNDERSTOOD AND FOLLOWED. THE FOLLOWING MAINTENANCE PROCEDURES SHOULD BE PERFORMED REGULARLY:

- General visual inspection of de-energized circuit breaker.
- Keep mechanism clean and adequately lubricated.
- Keep insulation materials dry and clean.
- Keep connectors in place and properly adjusted.
- Repair or replace any items functioning improperly.
- Check circuit breaker for smooth and correct operation before returning to service.

Annually, a general visual inspection should be performed on de-energized breakers. Where the application imposes dusty or other severe ambient conditions and/or frequent switching operations the following inspection checks should be more frequently applied than for normal maintenance.

THESE INSTRUCTIONS DO NOT REPRESENT AN EXHAUSTIVE SURVEY OF MAINTENANCE STEPS NECESSARY TO ENSURE SAFE OPERATION OF THE EQUIPMENT. PARTICULAR APPLICATIONS MAY REQUIRE FURTHER PROCEDURES. SHOULD FURTHER INFORMATION BE DESIRED OR SHOULD PARTICULAR PROBLEMS ARISE WHICH ARE NOT COVERED SUFFICIENTLY FOR THE PURCHASER'S PURPOSES, THE MATTER SHOULD BE REFERRED TO THE LOCAL SIEMENS-ALLIS SALES OFFICE.

THE USE OF UNAUTHORIZED PARTS IN THE REPAIR OF THE EQUIPMENT OR TAMPERING BY UNQUALIFIED PERSONNEL, WILL RESULT IN DANGEROUS CONDITIONS WHICH CAN CAUSE SEVERE PERSONAL INJURY OR EQUIPMENT DAMAGE. FOLLOW ALL SAFETY INSTRUCTIONS CONTAINED HEREIN.

	Warning
	Hazardous voltages and high speed mechanical parts can cause death or severe personal injury, and property damage. Read instruction manual, observe safety instructions and limit use to qualified personnel.

Inspection Check List

1. Check vacuum, procedure follows.
2. Check contact erosion, procedure follows.
3. Clean circuit breaker, especially post insulators and insulating couplers.
4. Lubricate all bearings and sliding surfaces, procedure and materials follow.
5. Check all terminal screws.
6. Check all screw connections and locking devices on mechanism parts.
7. Check all control cables and connections.
8. Perform functional test of circuit breaker.

Hand Tools Recommended

The 3AF breakers employ both English and Metric fasteners. Metric fasteners are confined to the circuit breaker subassembly. The supporting drawout vehicle uses English sizes. The following tool list has been prepared primarily to identify the tool requirements normally expected.

General

- Screw Drivers, 0.032 x 1/4 and 0.055 x 7/16
- Pliers
- Light Hammer
- Drift Pin, 1/8, 3/16, 1/4
- Retaining Ring Plier; External Type Tip Diameter 0.040"

Metric

- Sockets and Open-end Wrenches:
7mm, 8mm, 9.5mm, 10mm, 11mm, 13mm, 17mm, 19mm, 24mm
- Hex Key:
2mm, 5mm, 6mm, 8mm, 10mm
- Torque Wrench, 0-150Nm (0-100Lb. Ft.)

INTERRUPTER/OPERATOR Maintenance

English

- Sockets and Open-End Wrenches:
5/16, 3/8, 7/16, 1/2, 9/16, 3/4, 7/8
- Hex Key:
3/16, 1/4

Minimum Maintenance Schedule

The Maintenance intervals indicated in Table 7 are for equipment installed in accordance with "Usual" operating conditions as defined by ANSI. If 'Unusual' operating conditions are experienced by the equipment, the operating intervals between maintenance should be reduced as required for those conditions.

Lubrication:

The operating mechanism should be oiled and lubricated at least every 10 years or within the operations interval indicated in Table 7, whichever occurs first.

Overhaul:

Within the operations interval indicated in Table 7, the circuit breaker should be maintained in accordance with the following recommendations and the following components replaced:



- Vacuum Interrupters
- Closing Solenoid, 52SRC
- Opening Solenoid, 52T
- Trip Free Drive Bar Mechanism

When these parts are changed, locking devices must also be removed and replaced. These include lock-washers, retaining rings, retaining clips, spring pins, cotter pins, etc.

Table 7
Maintenance Intervals
Under 'Usual' Operating Conditions per ANSI C37.04
Minimum Maintenance Interval Close Operations

Type Breaker	Close Operation	
	Lubrication	Overhaul
5-3AF-250	10000	30000
5-3AF-350	3000	10000
7-3AF-500	10000	30000
15-3AF-500	10000	30000
15-3AF-750	10000	30000
15-3AF-1000	3000	10000

Lubrication of the Operating Mechanism

 Warning	
	<p>Hazardous voltages and high speed mechanical parts can cause death, personal injury and property damage.</p> <p>Before starting any work, breaker should be isolated, short circuited and grounded. Control power should be disconnected and breaker closed and opened by hand until both springs have been discharged.</p>

The main points to be lubricated with grease (bearings and sliding surfaces) are indicated in Fig. 18. All the points not marked (bearings, articulated joints and auxiliary switch) should be treated with light machine oil with rust inhibitor.

www.ElectricalBooks.com

INTERRUPTER/OPERATOR Maintenance

Page 26

To relubricate the mechanism remove the cover. Lubricate all the appropriate points starting at the top left and working through systematically. Parts that are not rigidly fixed (e.g. articulated joints) should be moved slightly to and fro to let the oil penetrate. Following this, operate the breaker several times to test it.

Articulated joints and bearings that cannot be dismantled should not be cleaned with a cleaning agent prior to being oiled.

See Vehicle Lubrication section for additional information.

Lubricating Materials:

Bearings and Sliding Surfaces

Beacon 325, Humble Oil and Refining Co., Or
15-337-131 -001

Centoplex 24.DL, Klueber Lubrication Corp.
Greiner Industrial Park, Manchester, N.H. 03103

Pivots and Articulated Joints, Auxiliary Switches, etc.

Tectyl 910 Valvoline Oil Co., Division of Ashland
Oil Inc.

Ashland Dr., Ashland, Ky. 41101

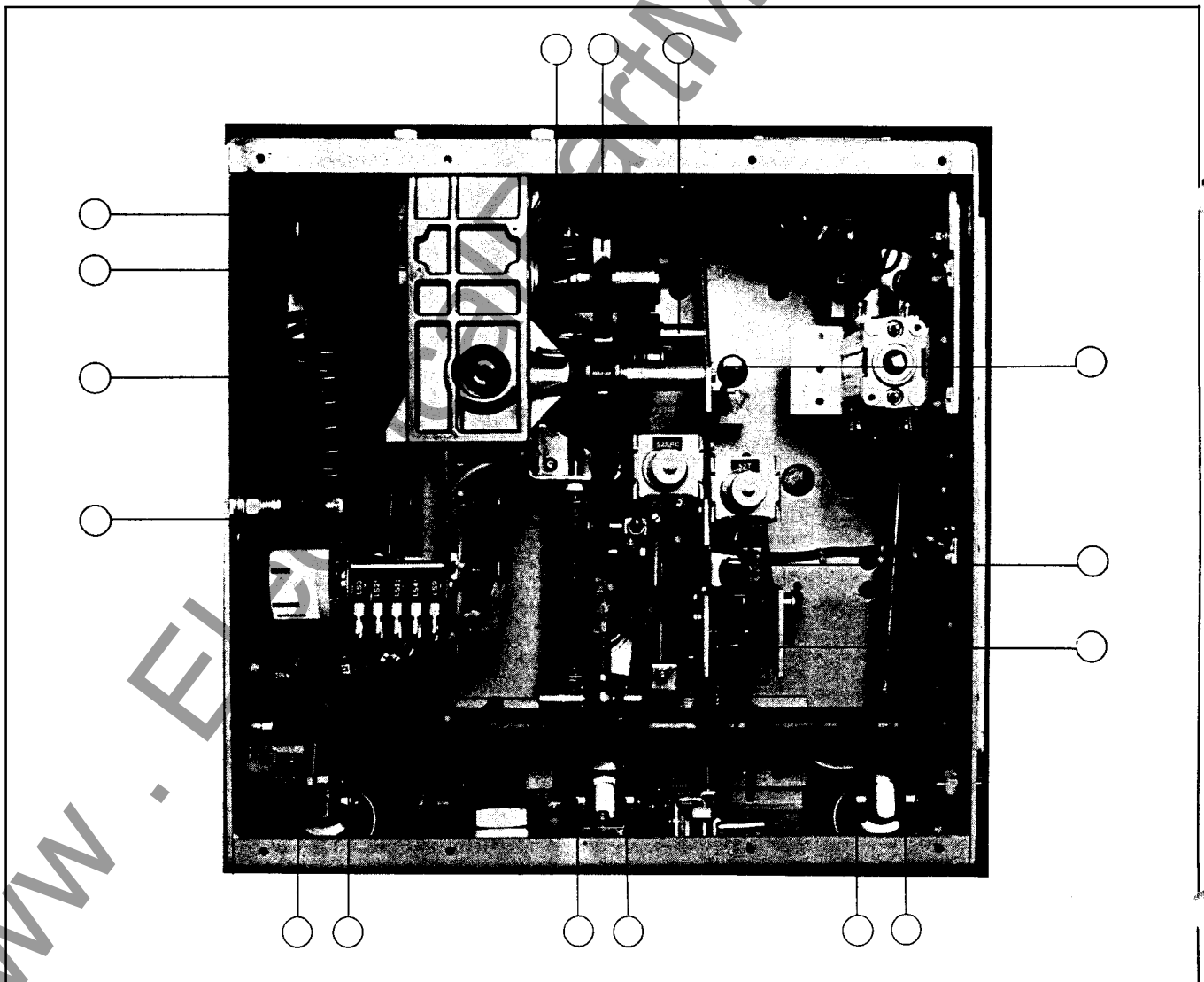

Figure 18
Operator Lubrication Points

INTERRUPTER/OPERATOR Maintenance

Hydraulic Shock Absorber

The 3AF mechanism is equipped with a hydraulic shock absorber and a stop bar that functions when the breaker opens. See item 61.8 Figure 11. The shock absorber should require no adjustment. However, at maintenance checks, the shock absorber should be examined for evidence of leaking. If evidence of fluid leakage is found, the shock absorber must be replaced to prevent damage to the vacuum interrupter bellows.

Vacuum Interrupters

Life Expectancy

The life expectancy of vacuum interrupters is a function of the number of interruptions and magnitude of current interrupted.

$$\text{Life} = \text{Interruptions} \times \text{Current}$$

They must also be replaced before 30,000 mechanical operations or when the contacts have been eroded beyond allowed limits. Vacuum tube replacement procedures are detailed in the following maintenance instructions.

As a guide to life expectancy the curves in Figure 19 are offered.

3AF Breaker Designation	Volts kV	5-250	5-350	7-500	15-500	15-750	15-1000
	Nom.mVA						
	Rated Max. Volts, kV	4.76		8.25		15.0	
	Rated Short-Circuit Current, kA	29	41	33	18	28	37
	Rated Continuous Current, A						
	1200	a	b	c	d	e	f
	2000	a	b	c	d	e	f
	3000	-	b	c	-	e	f

Applicable Curve a Function of Breaker Rating

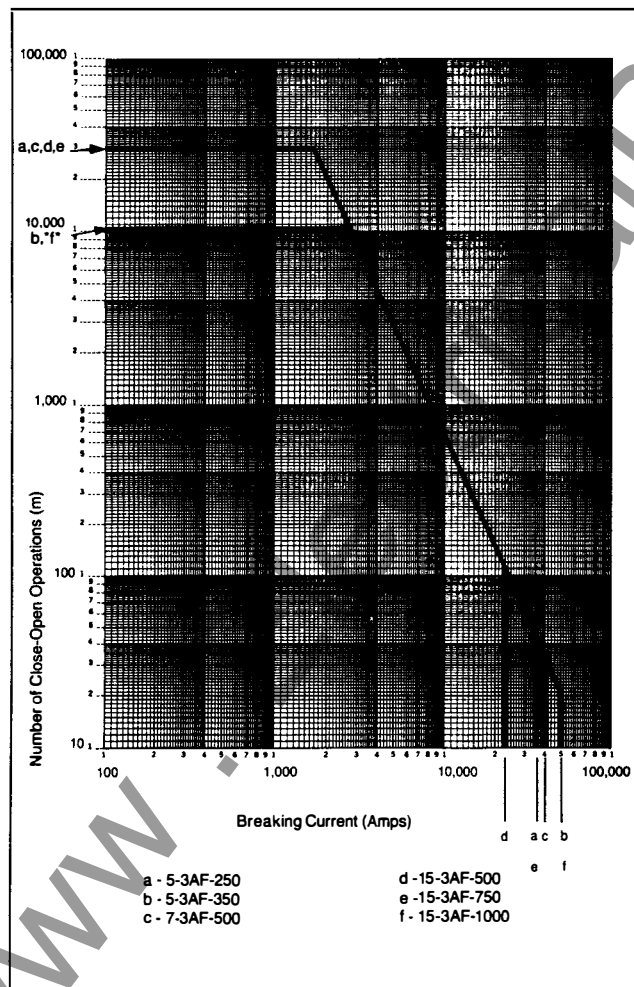

Figure 19

Typical Primary Interrupter Contact Life Curves

Contact Erosion

Vacuum interrupters should be checked periodically for contact shortening, which is normally associated with erosion of contact material during high fault current interruptions. Contact shortening or erosion is normally not expected to be significant until the number of operations indicated for contact life is approached. When the number of operations reaches the indicated contact life or excessive contact shortening or erosion is indicated, the interrupter tubes should be replaced. Contact erosion or shortening normally is checked by the visibility of the erosion mark. Alternately it may be checked by measuring the contact stroke.

Contact erosion is checked on a closed breaker by visually observing a white dot erosion mark (A) on the exposed movable contact stem of the interrupter, see Figure 20. NOTE: the tripping springs are charged and the circuit breaker could open unexpectedly.

The mark (A) may be seen above the lower primary connection, and just above the terminal clamp which fastens the flexible connector (29.1) to the movable stem of the vacuum tube.

The criteria of acceptance is that as long as the white erosion mark or any part of it can be seen with the breaker closed, contact wear is within permissible limits.

INTERRUPTER/OPERATOR

Maintenance

Page 28

Contact stroke measurement may be made by the procedures described in paragraph 3.0. 'Checking the Contact Stroke' under 'Vacuum Tube Replacement' later in this section.

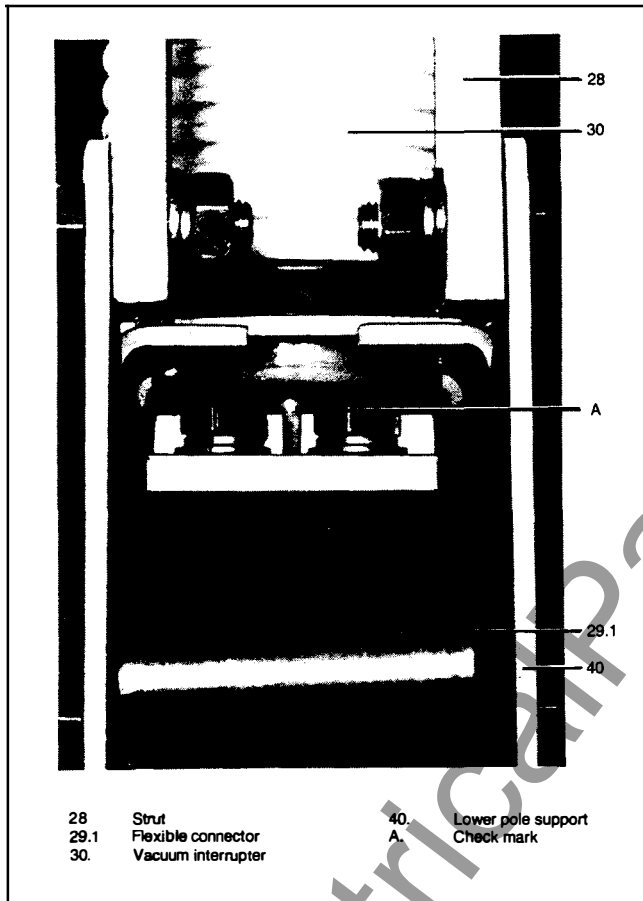

Figure 20
Contact Erosion Check

Adjustment of the contact gap may be necessary on higher interrupting capacity circuit breakers which are subjected to repeated high fault current interruptions. These procedures should be used at least each time a high interrupting capability circuit breaker, interrupter experiences about 25% of expected life under full high fault current interruptions. The type 5-3AF-350 and type 15-3AF-1000 circuit breakers should be checked at approximately 4 full fault interruptions, for example. If the stroke is not in the proper range it should be brought back into proper adjustment using the procedures described in paragraph 3.0.

Interrupter Vacuum Check—Mechanical (Ref. figs. 21a, 21b, & 21c)

Checking the Vacuum

Before putting the breaker into service, or if an interrupter is suspected of leaking as a result of mechanical damage, check the vacuum as follows:

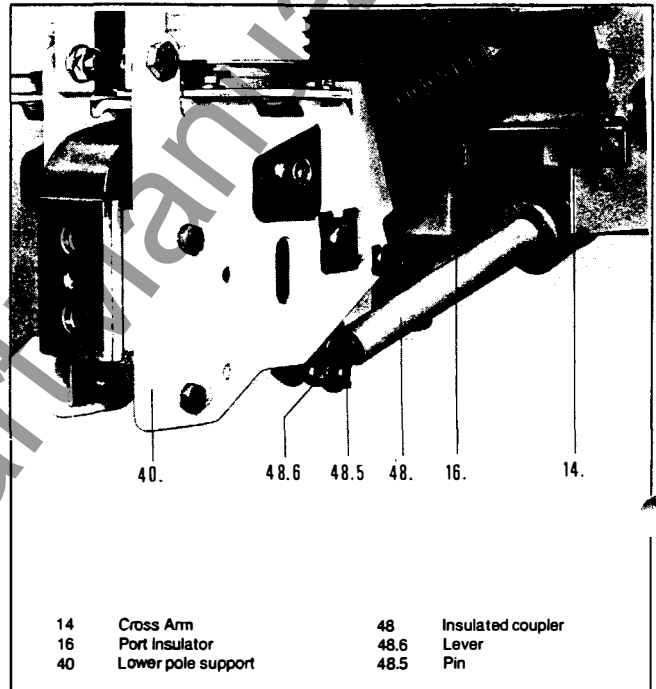

Figure 21a. Lower Pole Support With Insulated Coupler

Open and isolate the breaker and detach the insulated coupler, 48, from lever, 48.6, Fig. 21a.

The atmospheric pressure will force the moving contact of a hermetically sealed interrupter into the "Closed" position, causing lever, 48.6, to move into the position shown in Fig. 21b.

A vacuum interrupter may be assumed to be intact if it shows the following characteristics:

An appreciable closing force has to be overcome when lever, 48.6, is moved to the "Open" position by hand, Fig. 21c. When the lever is released, it must automatically return to the "Closed" position with an audible sound as the contacts touch.

After checking the vacuum, reconnect the lever, 48.6, to the insulated coupler 48.

INTERRUPTER/OPERATOR Maintenance

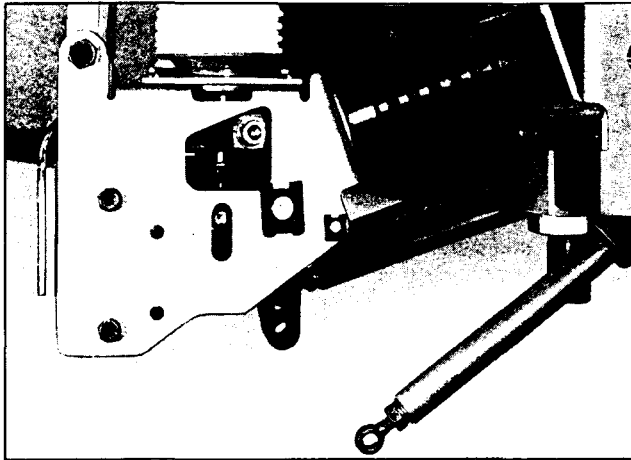

Fig. 21b Primary Contact Closed - Free Position

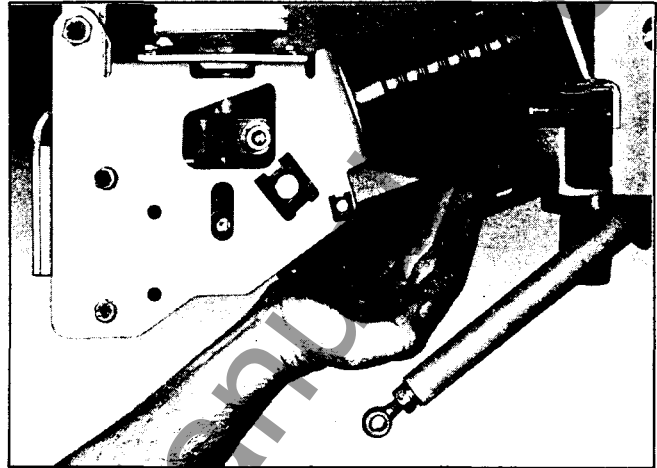



Fig. 21c Primary Contact Forced Open by Manual Pressure

High Potential Testing and Electrical Interrupter Vacuum Check

High Potential tests are performed to affirm the breakers dielectric integrity, and to establish by alternate means of checking the interrupters vacuum.

Prior to applying the test voltage, each pole not under test shall be grounded. Apply test voltage for one minute. If no disruptive discharge occurs which permanently reduces the test voltage to zero, the primary insulation system is acceptable.

	⚠ Danger
	<p>High Potential Tests employ extremely hazardous voltages which will cause severe personal injury and death.</p> <p>Follow safe procedure, exclude unnecessary personnel, barrier test vehicle and keep well away from breaker during test voltage application. After test, ground ends and middle of vacuum tube to remove static charge.</p>

Interrupter vacuum may be checked by applying the test voltages listed across each interrupter with the breaker open. Test voltage should be raised gradually, and the contact gap must sustain the voltages listed below, appropriate the breakers rating, for one minute. If it does not, the interrupter is faulty and must be replaced.

	⚠ Caution
	<p>Vacuum Interrupters can emit X-Radiation causing personal injury.</p> <p>Do not apply test voltages to the interrupters which exceed the values listed below. Test personnel must remain a minimum of six feet away from interrupter under test.</p>

	Caution
	<p>Erroneous test results may occur. Vacuum interrupters can emit X-Radiation causing personal injury.</p> <p>Many DC high potential machines are halfwave rectifiers. This type of HiPot tester must not be used to test vacuum interrupters. The capacitance of the interrupter is very low and the leakage in the rectifier and its DC voltage measuring equipment is such that the pulse from the half wave rectifier may be approximately 120k V when the meter is actually reading 40k V. In this case, good interrupters may show a relatively high leakage current since it is the peak voltage of 120k V that is producing erroneous leakage current. In addition, abnormal X-Radiation may be produced.</p>

The primary insulation system of the circuit breaker may be checked by closing the breaker, and applying the voltages listed below between a primary conductor of each pole and ground.

Breaker Max. KV	A.C. Potential	D.C. Potential
5 KV	14 KV	20
7 & 15 KV	27 KV	38

INTERRUPTER/OPERATOR

Vacuum Interrupter

Page 30

Vacuum Tube Replacement

Replacement interrupters are furnished as a complete assembly. They have been completely tested and dielectrically and mechanically conditioned. The interrupters, when installed, do not require that they be operated no-load a set number of times or voltage tested to condition the contacts.

It is recommended that one interrupter be removed and replaced completely rather than removing two or more interrupters at a time. The following procedure in check list format describes the procedure for removing and replacing a vacuum interrupter. Components may be identified by reference to figures 5, 6, 22 & 23.

1. Removing The Interrupter

- 1.1 Before starting work, the circuit breaker should be isolated from all primary and control power sources and all stored energy discharged by tripping, closing, and tripping the breaker by hand. Discharge any static charge by grounding all end and center metal sections of the vacuum interrupter. Carefully remove inter-phase barriers.

	Warning
	<p>Hazardous voltages and high speed mechanical parts can cause death, personal injury and property damage.</p> <p>Before starting any work, breaker should be isolated, short circuited and grounded. Control power should be disconnected and breaker closed and opened by hand until both springs have been discharged.</p>

- 1.2 Loosen the lateral bolt(s) on terminal clamp, 29.2. Refer to figure 23 and employ the illustrated procedure to loosen clamp hardware. (8mm hex allen and 17mm socket)
- 1.3 Withdraw pin, 48.5, from insulating coupler, 48, and levers, 48.6.
- 1.4 Remove coupling pin from the eye bolt, 36.3.
- 1.5 Free struts, 28, from the upper pole support, 20. Loosen the strut hardware on the lower support, 40, and swing the struts forward and downward. (17mm open end and 17mm socket)
NOTE: Some breakers may employ four struts. The additional struts should also be freed from the upper pole support, loosened at the lower pole support and swing the struts rearward and downward.

- 1.6 Loosen screws fastening the centering ring, 28.1. (10mm open end)
- 1.7 Remove bolt "B", lockwasher and large washer at stationary contact of the vacuum interrupter. (24mm socket). Carefully note location of conductive spacers between interrupter and pole support.
- 1.8 Using a deep 24 mm socket loosen and remove hex capscrew fastening the upper pole support to the post insulator. Completely remove the upper pole support and set aside.
- 1.9 Grasp the vacuum interrupter and withdraw vertically. Assistance may be required to work the terminal clamp off the movable stem of the tube. **FORCIBLE TWISTING EFFORT IS NOT ALLOWED.** If the terminal clamp cannot be easily removed, **STOP!**, check to be certain hardware is loose and the clamp is not bound.

2. Installing the Interrupter

NOTE Replacement interrupter, 30, will be received from the factory with an eyebolt, 36.3, in place adjusted and torqued to specific requirements. **DO NOT ALTER THE EYEBOLT SETTING.**

- 2.1 Inspect all silver plated connection surfaces for cleanliness. Clean only with a cloth and solvent. Do not abraid.
- 2.2 Insert interrupter, 30, in the lower pole support, 40, with the evacuation nipple 'P' facing the mechanism housing. Slip terminal clamp, 29.2, into position on the movable stem.
- 2.3 Restore any conductive spacers which may have been provided to span the space between tube and pole support. Locate the upper pole support and fasten "finger tight" using heavy flat washer, lockwasher and bolt, 'B'.
- 2.4 Fasten the upper pole support to the post insulator using finger pressure only using hex head bolt, lockwasher and flat washer.
- 2.5 Attach struts, 28, to the upper pole support, 20, replace hardware, but do not tighten at this time.
- 2.6 Couple lever, 48.6, and drive link, 48.9 to the eye bolt, 36.3, using the pin supplied. Apply retention clips. Appropriate pin is modestly chamfered, not to be confused with pin for the insulated coupler.

INTERRUPTER/OPERATOR

Vacuum Interrupter

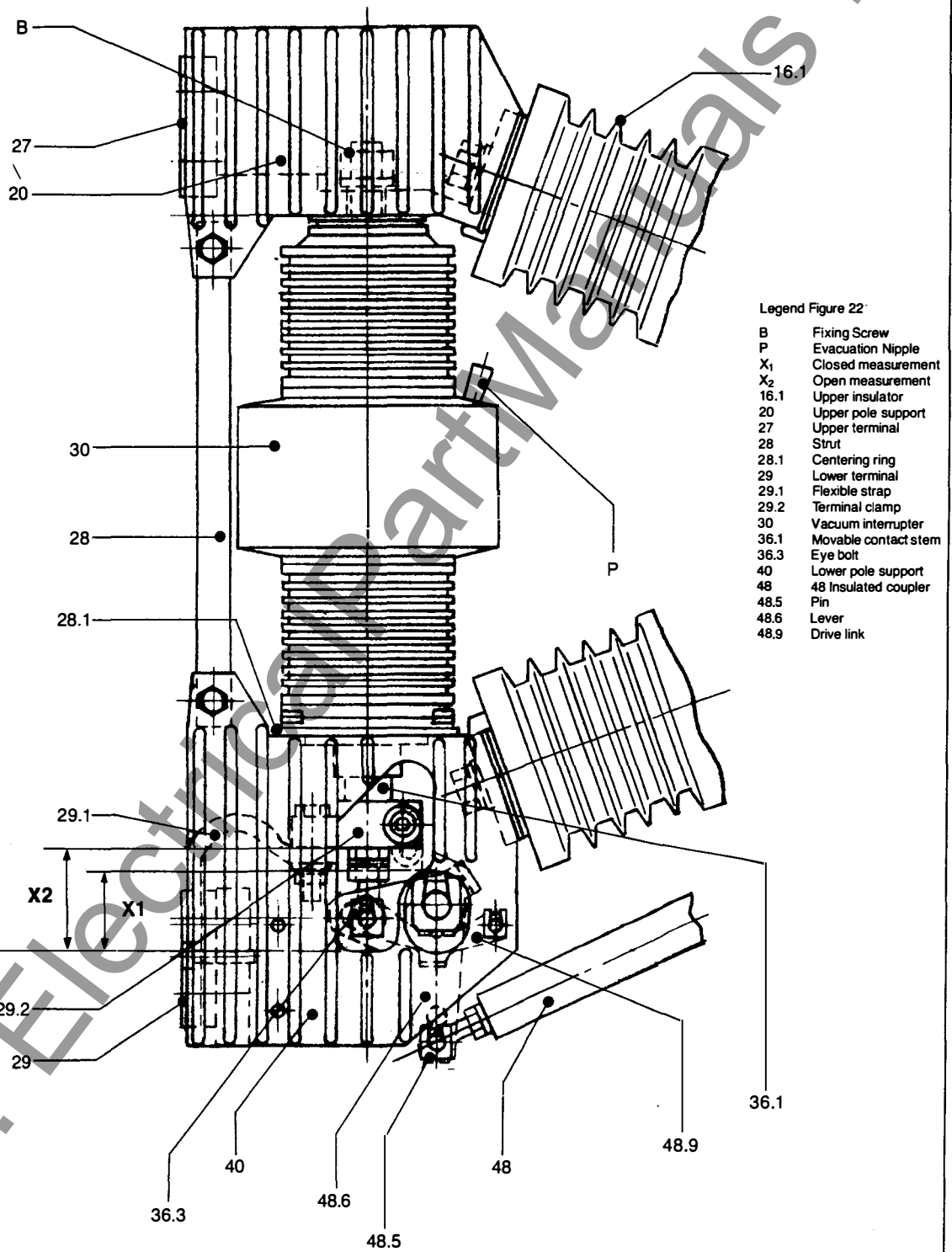

Figure 22
Vacuum Tube Replacement Illustration

INTERRUPTER/OPERATOR

Vacuum Interrupter

Page 32

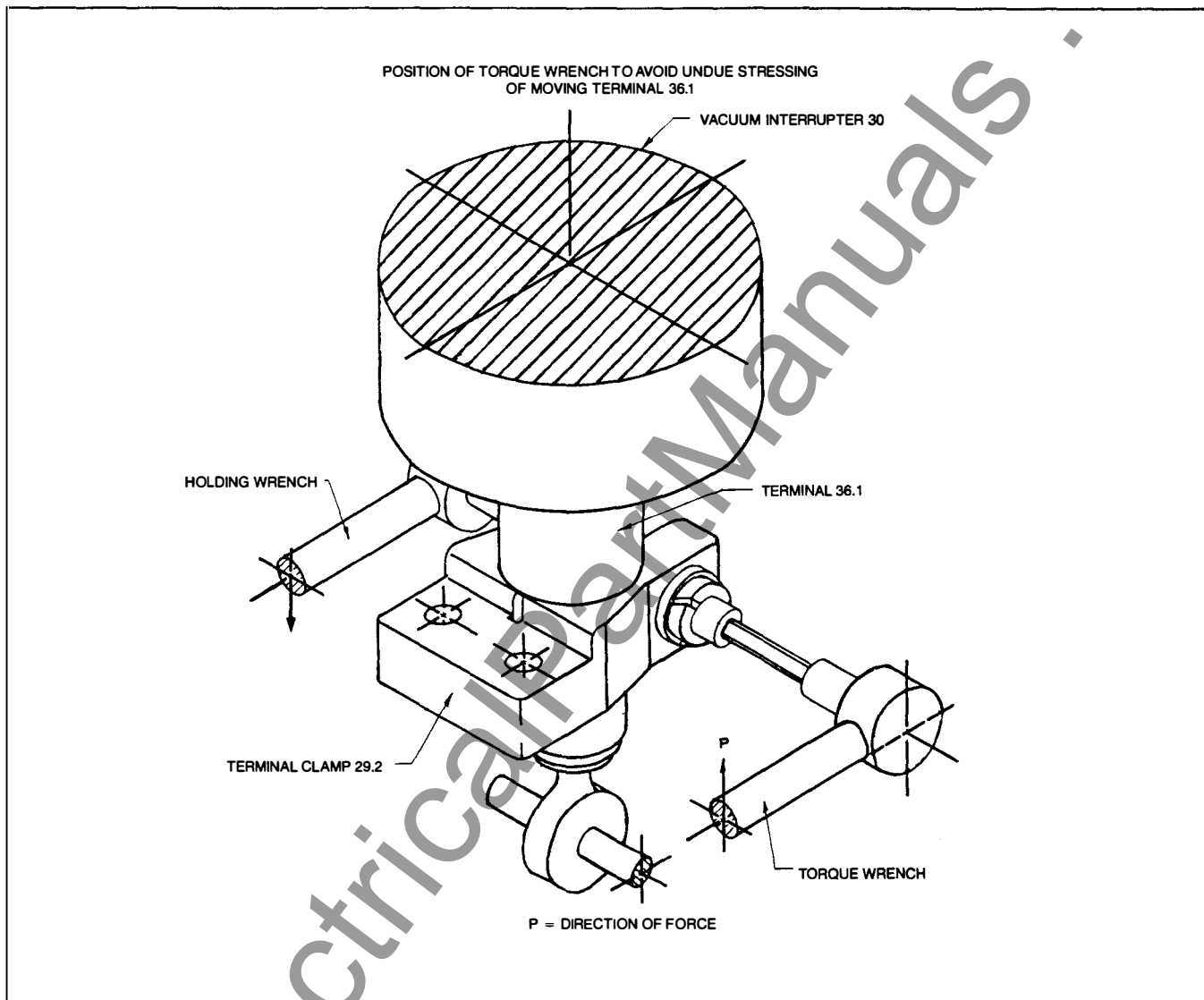

Figure 23
Illustration Showing Required Technique
For Fastening Terminal Clamp Hardware

2.7 Elevate terminal clamp, 29.2, against the locking ring on the movable terminal of the vacuum tube, 36.1 and position the interrupter 30, so that its groove faces the connecting surface of flexible strap 29.1. Refer to Figure 23 and employ technique illustrated to fasten terminal clamp. Note opposing wrenches. Tighten the bolt(s) of the terminal clamp to a torque of 30 Lb. Ft. (40 Nm), taking care to see that the copper terminal of the interrupter is not subjected to excessive bending moments.

NOTE Excessive bending movement exerted while fastening the terminal clamp will damage the vacuum interrupter.

- 2.8 Align pole support, 20, correctly and tighten bolt fastening it to the post insulator. Fasten securely all bolts associated with struts, 2.8.
- 2.9 Tighten interrupter fastening bolt 'B' on the upper pole support, 20, holding the interrupter firmly by its upper insulator, and operate levers, 48.6, by hand to see whether the movable contact moves freely. If any binding or lack of freedom is noted, loosen bolt 'B' and adjust the interrupter in pole support by turning and moving it slightly.

INTERRUPTER/OPERATOR

Vacuum Interrupter

Page 33

- 2.10 Press centering ring segments firmly against base of tube, and fasten securely. On some breaker a one piece ring is used, and this is simply fastened in place.
- 2.11 Attach insulating coupler, 48, and lever, 48.6 together using pin 48.5. Apply retaining clips. Correct pin has ends which have been generously chamfered.
- 2.12 Open and close breaker several times, and then check to see that all bolted joints and devices are tight.
3. Checking the Contact Stroke
- 3.1 Open the circuit breaker.
- 3.2 Free insulating coupler, 48, by removing pin 48.5. The interrupter contacts most now close automatically as a consequence of atmospheric pressure.
- 3.3 Observe the terminal clamp, 29.2 thru the openings on each side of the lower pole support, 40. Using vernier calipers measure the distance "X", from the bottom surface of the terminal clamp to the bottom edge of the cutout opening. Measure carefully, and record your result.
- 3.4 Connect the insulating coupler, 48, using pin, 48.5, and the retaining clips provided.
- 3.5 Repeat the measurement described in item 3.3 again with care to maximize accuracy, record your result, "X₂".
- 3.6 Determine difference ($X_1 - X_2$) between the measurements made under items 3.3 (X_1) and 3.5 (X_2). Your result should be:
- Type 5-3AF-250 Breakers 5 to 7mm (0.20 to 0.27 inches)
 - Type 7-3AF-300, 15-3AF-500 and 15-3AF-750 Breakers 10 to 12mm (0.40 to 0.47 inches)
 - Type 5-3AF-350, 15-3AF-1000A and all 3000A breakers 7.5 - 8.5mm (0.30 - 0.33 inches).
- 3.7 If you fail to achieve the listed results carefully repeat the entire procedure making certain of your measurements.
- 3.8 If after confirming your measurements, you find the stroke not in agreement with the values given above, an adjustment can be made by adjusting the eyebolt, (48.6) at the end of the insulated coupler 48. (**Note: do not adjust eyebolt 36.3 on interrupter**).
- Excessive stroke is corrected by turning the eyebolt out.
 - Insufficient stroke is corrected by turning the eyebolt in.
- 3.9 Loosen locking nut on eyebolt on insulated coupler (48), and retain position of the eye. Make adjustments in one-half turn increments. After adjustment is completed, tighten eyebolt locking nut to 3014 Lb. Ft. (40 ± 5 Nm).
4. After eyebolt is tightened to proper torque, repeated all measurement procedures making certain they are in agreement with values indicated in 3.6.
- 4.1 Complete all other maintenance procedures completely reassembled breaker should pass high potential test before it is ready for service.

Solenoid Replacement

Replace closing solenoid, 52SRC, and opening solenoid, 52T.

- Remove two "push on" terminal connections.
- Remove two M4 hex head screws and dismount solenoid drawing it towards you.
- Install replacement solenoids with two M4 hex head screws and replace "push on" terminals.

Operational Check

When work is finished operate circuit breaker, close open, several times, and check that all screw connections are tight.

VEHICLE Description

Page 34

Description

The Siemens-Allis 3AF vacuum circuit breaker is comprised mainly of the interrupter/operator sub-assembly fitted to a drawout truck sub-assembly. This interrupter/operator sub-assembly is an integral arrangement of operating mechanism, dielectric system, vacuum interrupters, and means of connecting the primary circuit. The drawout truck sub-assembly supports the interrupter/operator sub-assembly, providing mobility and fully coordinated application in Siemens-Allis type H2 switchgear.

Successful coordinated application of the fully assembled 3AF vacuum breaker is achieved thru precise fixtured alignment and important functional interlocking.

Alignment

Elements of the vehicle structure, which are assembled under fixture control and then are secured, include the following (no adjustments are required):

- Cam roller guide wheels on truck assembly.
- The primary circuit conductors are fixtured to appropriate elevation, phase spacing and alignment to the racking block and guide wheels.
- Secondary disconnects are fixtured and secured in place.
- Shutter cam which raises and lowers protective primary bushing barriers, is fixtured.
- Breaker grounding bar is aligned and securely bolted in place.
- "TOC" switch actuator is located and secured.

Thus, all those features which must align with elements of the switchgear "drawout" enclosure, are precisely set and, firmly secured while the complete breaker is located in a rigid fixture.

Interlocks

	Warning
	<p>Inoperative or by-passed interlocks can cause death, serious personal injury and property damage.</p> <p>Mechanical and electrical interlocks are provided as integral components of this equipment to ensure safe use. Interlocks must be in operation at all times.</p> <p>Read this instruction manual. Know and understand correct interlock function.</p> <p>Check interlock function prior to inserting breaker into switchgear cubicle.</p>

Type H2 switchgear is designed for open or closed door screw racking of type - 3AF - vacuum circuit breakers between the 'connect' and 'test/disconnect' positions, only when the circuit breaker is open. It is also designed to ensure that the closing springs are discharged upon insertion or 'withdrawal of the circuit breaker from its cubicle if the proper procedures were not followed. A system with racking and the trip-free movement interlocks is employed to perform these functions.

The circuit breaker primary circuit is closed by means of the vacuum interrupter contacts. The circuit breaker primary circuit is open (released) by means of the electrical or mechanical releases. These conditions are caused by the rotation of the circuit breaker shaft (63).

VEHICLE Description

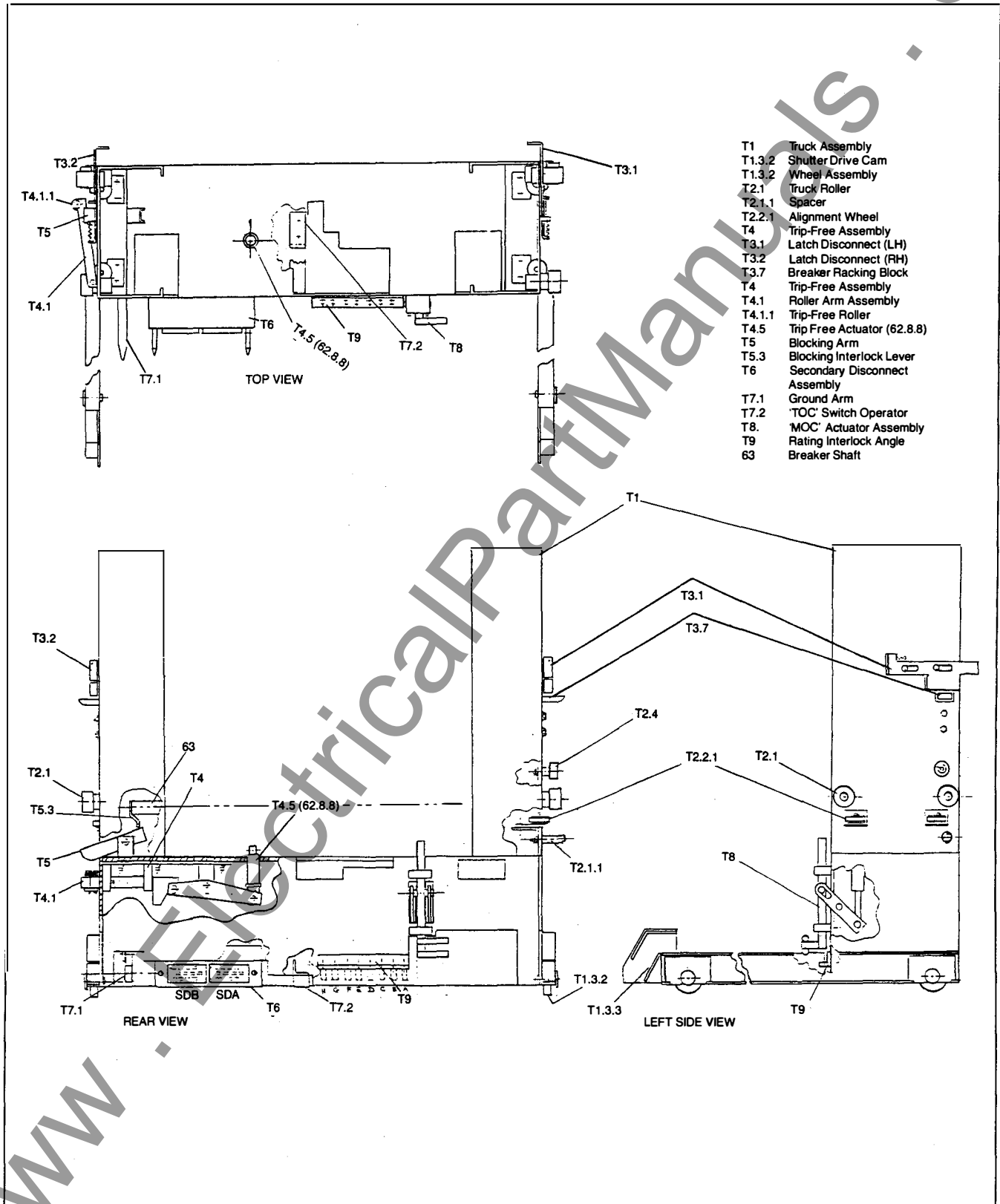

Figure 24
Drawout Truck Subassembly
Showing Major Cubicle Interface Items

VEHICLE Description

Page 36

Closed Breaker Racking Interlock

The racking interlock is the combination of a block arm (T5) on the right side of the circuit breaker and an interlock plate assembly (55 Fig. 25) mounted on the right side of the cubicle. This combination blocks engagement of the racking screw drive mechanism unless the circuit breaker is open and prevents movement of a closed circuit breaker in its cubicle.

When the circuit breaker closes, a lever (T5.3) on the breaker shaft (63) causes the blocking arm (T5) to be raised, where it remains until the circuit breaker is opened. If the circuit breaker is closed outside of its cubicle, the raised blocking arm allows only partial insertion into the cubicle.

Inside the cubicle, the raised blocking arm is held by the rectangular slot of the interlock plate assembly and the closed circuit breaker cannot be moved out of either the 'connect' or 'test/disconnect' positions. With the circuit breaker closed, the interlock plate assembly holds a shield (42 Fig. 26) over the hex-head drive nut (43 Fig. 26) on the shaft of the screw racking mechanism. When held in place, the shield prevents the racking crank from being engaged and the breaker can not be moved.

Three holes (44 Fig. 26) for padlocks are included on the racking interlock assembly, which can keep the shield over the hex-head drive nut on the shaft of the screw racking mechanism. With a padlock in place, racking of the circuit breaker will be prevented. This may be desired during maintenance or other operations.

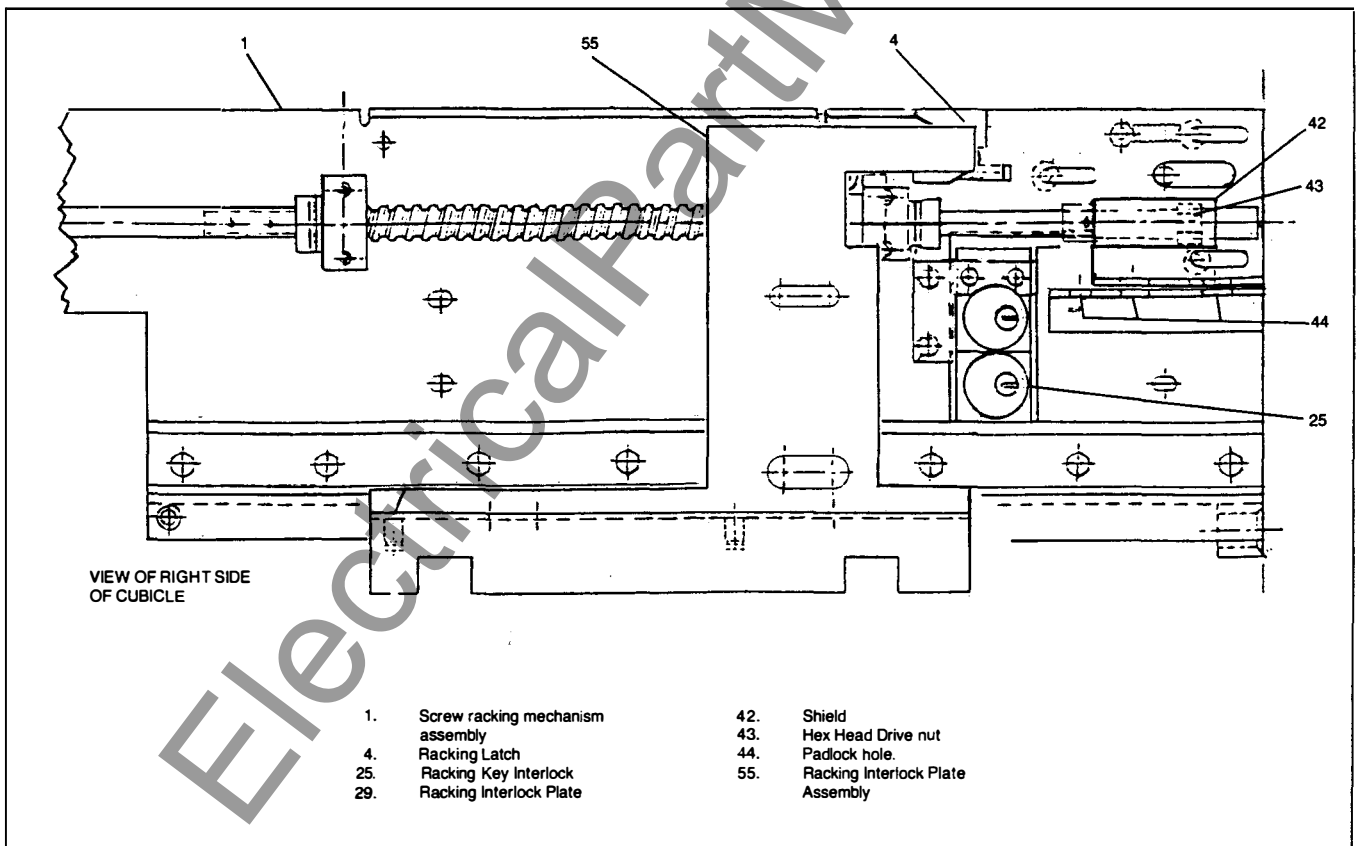

Figure 25 Closed Breaker Racking Interlock Plate Assembly
(Superimposed over screw racking mechanism)