

# METAL-CLAD SWITCHGEAR

## **INSTRUCTIONS**

TYPE 5HK, 7.5HK, AND 15HK  
METAL-CLAD SWITCHGEAR  
5000, 7500, AND 15000 VOLT

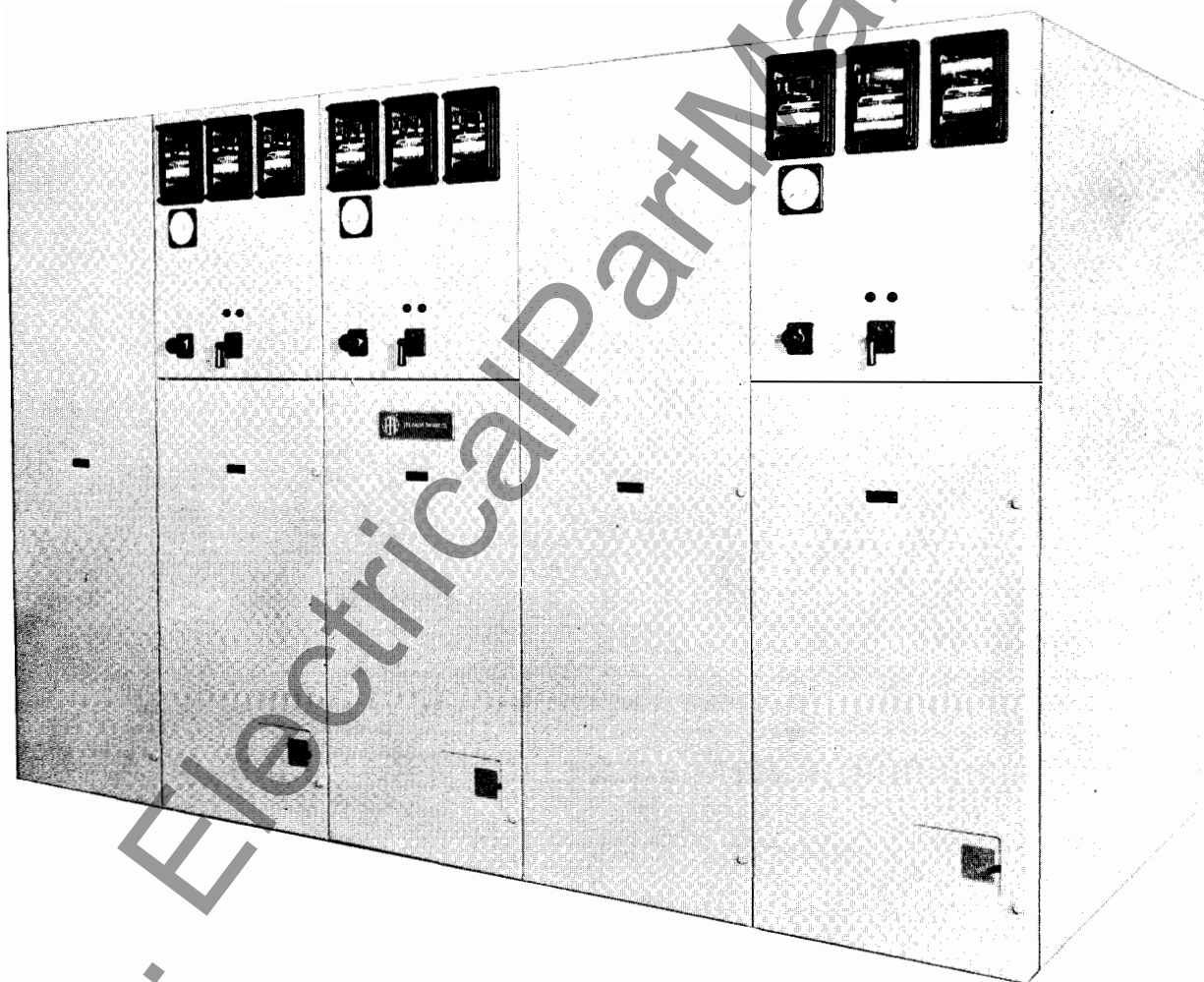

**I-T-E CIRCUIT BREAKER COMPANY**



**CONTENTS**

SECTION	PAGE
<b>INTRODUCTION</b> .....	3
<b>SCOPE OF INSTRUCTIONS</b> .....	3
<b>TRANSPORTATION</b> .....	3
<b>STORAGE</b> .....	3
<b>UNLOADING AND HANDLING</b> .....	4
INDOOR INSTALLATION .....	4
OUTDOOR INSTALLATION .....	5
<b>INSTALLATION OF HOUSINGS</b> .....	5
GENERAL .....	5
PREPARATION OF FLOOR .....	5
ASSEMBLING THE HOUSINGS .....	5
CONNECTION OF PRIMARY CABLES .....	6
ROOF BUSHINGS .....	6
CONNECTION TO GROUND BUS .....	6
CONNECTION TO CONTROL SOURCE .....	7
INSTALLATION OF BUS BAR CONNECTION BETWEEN GROUPS .....	7
TESTING AND INSPECTION .....	7
FINAL INSPECTION .....	7
<b>STANDARD CONSTRUCTION</b> .....	8
SHUTTERS .....	8
BUS INSULATION .....	8
PRIMARY DISCONNECT DEVICE .....	8
SECONDARY DISCONNECTING DEVICES .....	8
GROUND BUS AND CONTACTS .....	8
CONTROL WIRES .....	9
<b>CIRCUIT BREAKERS</b> .....	9
GENERAL .....	9
<b>HOW TO PUT THE SWITCHGEAR IN SERVICE</b> .....	9
GENERAL .....	9
SAFETY PRECAUTIONS .....	9
PROCEDURE .....	9
<b>MAINTENANCE</b> .....	10
GENERAL .....	10
SEMI-ANNUAL INSPECTION .....	10
CARE OF FINISH .....	10
<b>RENEWAL PARTS</b> .....	10



## INSTRUCTIONS FOR TYPE 5HK, 7.5HK, AND 15HK METAL-CLAD SWITCHGEAR 5000, 7500, AND 15000 VOLT

### INTRODUCTION

Instructions for installation, operation and maintenance of metal-clad switchgear are furnished with each shipment.

These instructions should be read carefully and used as a guide during installation and initial operation.

File these instructions in a readily accessible place together with drawings and descriptive data of the switchgear. The use of these instructions will facilitate proper maintenance of the equipment and prolong its life and usefulness.

### SCOPE OF INSTRUCTIONS

These instructions are general. They cover requirements for installation as applied to all metal-clad switchgear of the following classification:

5HK75	7.5HK250	15HK150
5HK150	7.5HK500	15HK250
5HK250		15HK500
5HK350		15HK750
		15HK1000

Specific information on particular applications is furnished in the form of general arrangement drawings.

1. Front view showing arrangement of relays and instruments.
2. Single line diagram showing power connections.
3. Floor plan indicating available space for power and control conduits.
4. Special construction details.

The first sheet of the Bill of Material indicates the application of the drawings.

### TRANSPORTATION

Prior to shipment, the switchgear undergoes careful factory inspection. Each section is plainly marked at convenient places with its number and position. When size or other reasons make it necessary to divide the equipment for shipment, the unit number of the particular equipment is also marked on the section, along with its weight. The circuit breakers are shipped in individual cartons or crates.

Immediately upon receipt of the switchgear, examine for any damage or loss sustained during transportation. Check the contents against the packing list before discarding any packing material.

If there is any shortage notify the nearest I-T-E Circuit Breaker Company representative at once.

The I-T-E Circuit Breaker Company is not responsible for damage after delivery of shipment to the carrier. However, if the company is notified of such claims, it will furnish forms to facilitate securing any adjustments. If damage to the shipment indicates rough handling, claim for damage should be filed at once with the carrier and the I-T-E Circuit Breaker Company promptly notified.

Indoor switchgear housings are shipped in groups of one to five units. Each group is mounted on heavy steel shipping bases. Unloading and handling at the site is usually done by placing rollers under the shipping bases. To avoid distortion to the switchgear, any force to move the structures should be applied to the shipping bases by means of crowbar, block and tackle, crane, etc.

### STORAGE

Leave each switchgear group on its shipping base for subsequent moving. Remove circuit breakers and accessories from cartons or crates.

Observe the following precautions:

1. Check for missing or damaged parts.
2. Store in clean, dry place.
3. Cover parts susceptible to rust with heavy oil or grease.
4. Cover with heavy wrapping paper to keep dirt or dripping water from entering. Dirt or moisture may foul working parts or deteriorate contacts and insulation.
5. If the switchboard is to be stored for any length of time, or in any place where dampness may be present, then heaters should be used to keep the switchboard dry until it is placed in service. When outdoor switchboards equipped with heaters are stored, the power source for the heaters should be brought to the load terminals of the thermal circuit breaker or cutout device which controls the heater circuits.



### UNLOADING AND HANDLING

The following is a recommended method for unloading and handling metal-clad switchgear housings.

### INDOOR INSTALLATION

The switchgear should be unloaded as near to the installation site as possible. The operation may be completed by raising the switchgear shipping base with track jacks to allow rollers to be placed under the shipping bases.

#### Raising by Jacks

In most locations the practical way of handling the switchgear is by jacks.

1. After switchgear housings have been moved near site, raise the units by placing jacks under the shipping bases near the front and rear corners as shown in Fig. 1.

**CAUTION: DO NOT APPLY JACKS TO THE HOUSINGS AT ANY OTHER POINTS.**

Raise units evenly and just enough to position rollers. Repeat operation at other end of units so that rollers are equally distributed under units.

2. While a crew pushes the switchgear longitudinally towards its final position, one man should insert an additional roller under the forward end of the units. He should continue this operation by moving each roller that is freed from the rear end to the forward end until the units are in the desired position.

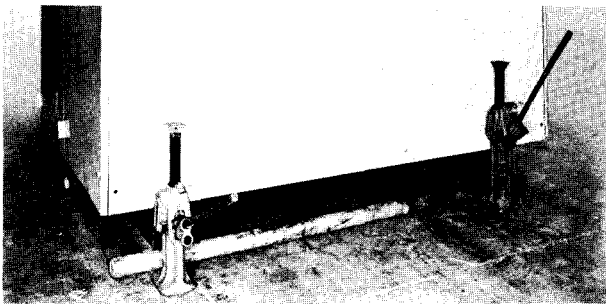

Fig. 1—Method of Raising Switchgear by Use of Jacks. Rollers in Place



Fig. 2—Longitudinal Moving of Switchgear from Shipping Skid

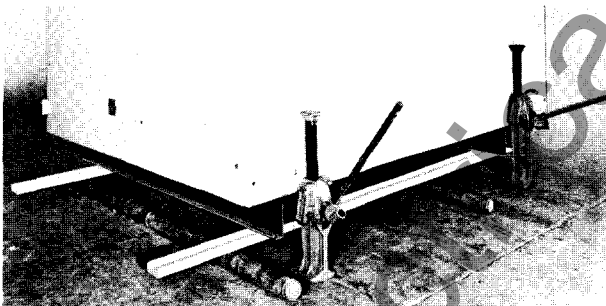

Fig. 3—Switchgear Raised, Rollers and Channels in Place Prior to Lateral Moving

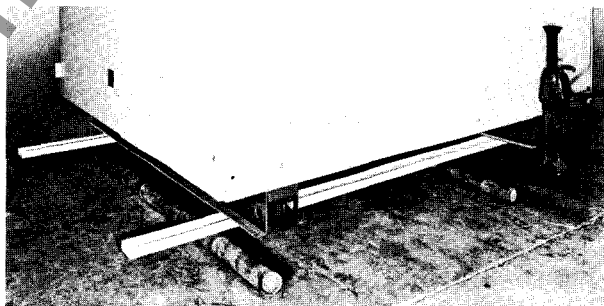

Fig. 4—Jacks Removed and Switchgear Ready for Lateral Moving

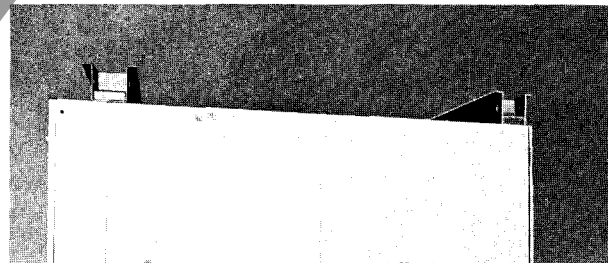

Fig. 5—Shipping Bases Bolted to Top of Switchgear

PHOTO D38337-R  
PHOTO D38335-R

PHOTO D38336-R  
PHOTO D38338-R

PHOTO D38339-R



3. For lateral moving, raise the units by jacks and remove the rollers. Place the rollers laterally with steel channels resting on the rollers as shown in Figs. 3 and 4. Move the units until they are directly over the installation site.

4. When the units are in their final place, raise the units enough to just clear the rollers and any channels resting on the rollers, by placing the jacks under the side sheets, near but not under the shipping bases. Remove the bolts inside the units which hold them to the shipping bases. Remove all the rollers, steel channels and shipping bases and lower the units by means of the jacks onto the floor. Lower the units evenly so as not to distort any of the structure.

### Raising by Slings

Where overhead lifting facilities are available, an alternate method of handling may be used for moving.

1. Holes are provided in the top of the units along the front and back which are spaced identically to those in the floor through which the shipping bases are bolted to the units.

2. Raise the units from the floor by placing the jacks under the side sheets near, but not under the shipping bases. Remove the bolts inside the units, which hold them to the shipping bases and withdraw the shipping bases. Lower the units to the floor evenly so as not to distort any of the structure.

3. Invert the shipping bases on top of the units and bolt to the top of the switchgear as shown in Fig. 5. All holes should be used to give uniform support to the housings and prevent distortion. Holes in the vertical webs of the shipping bases, equally spaced from each end, will permit the attaching of steel cable slings.

**NOTE:** Spreaders should be placed where necessary on the slings so that the cables rise vertically from the top of the units.

The switchgear should be raised high enough to clear projections above floor level, moved over the installation site and lowered into place. Then slings and shipping bases should be removed.

### OUTDOOR INSTALLATION

Outdoor installation is handled similarly to the indoor type. Outdoor switchgear is constructed with a steel base that serves as a shipping convenience as well as a permanent support for the internal housings. Jacks may be placed under the shipping bases to raise the whole structure for positioning rollers. Slings may be passed through the large holes in the vertical webs of the shipping bases. Note that the shipping bases are not removable and cannot be placed on top of the switchgear as in indoor installations.

Before assembling a Walk-In structure read the drawing "Erection Procedure", listed on the front sheet of the Bill of Material, carefully and follow procedure indicated thereon.

For proper assembly of Outdoor Non-Walk-In switchgear, consult the drawing entitled "Gasket Application" which is listed on the front sheet of the Bill of Material.

### INSTALLATION OF HOUSINGS

#### GENERAL

Before attempting any installation operations consult all drawings furnished by the I-T-E Circuit Breaker Company for the particular order. These drawings are in the form of floor plans, front views, primary and secondary wiring and a bill of material of the equipment furnished. Sections of housings for 5HK equipment consisting of five indoor units or less and four units or less in the case of 7.5 or 15HK housings, are shipped on a single base. Larger switchboards are divided in sections for shipment and each section is on its own base.

A removable angle is bolted across the front floor of each breaker housing to provide reinforcement while moving the housings on rollers. After final installation this angle should be discarded.

#### PREPARATION OF FLOOR

Floor plan drawings are supplied for each installation. Typical floor plan drawings are not enclosed since they usually vary with each installation due to length and arrangement of housings.

The design of the floor may include channel iron sills embedded in the concrete. It is important that these sills be straight and level their full length, and correctly spaced. To insure this condition, it is recommended that ties be bolted between the sills at various intervals after which the lower flange of the sill be shimmed to proper height.

Where necessary, power and secondary (control) conduits should be installed before the installation of the housings. Available space for the conduits is given on the floor plan accompanying each order. These conduits should not extend more than one inch above the station floor level. Take precautions to plug conduit openings before pouring cement.

The concrete floor in front of the housings should be smooth to facilitate the handling of the circuit breakers. The finished floor level should be flush with the top of the channel sills so that the circuit breaker will roll evenly into the housing. The cement should be prepared in accordance with instructions issued by the Portland Cement Association, available at their offices in the large cities.

#### ASSEMBLING THE HOUSINGS

When the floor has been properly prepared, assembly of the switchgear may be started. Sections of the housings may be moved on their bases adjacent to final positions. They may be moved to final location by putting rollers under the shipping bases. Before moving shipping sections together, remove projecting bus support bolts.

If the switchgear consists of a number of sections, the center sections should be installed first, and the remaining sections added at each end. When the first section is in position, it should be checked for distortion in shipment. This may be done by dropping a plumb bob from the center of the front and rear doors. If the structures are not true, they should be straightened before proceeding. As each section is added, it should be checked for distortion, otherwise considerable pressure may be required to bring the sections into alignment.



Holes are provided in the floor for plug welding the housings to the channel sills.

When shipment is made in sections, the main bus, control wiring, and inter connections are dismantled at the point where the switchgear is separated. These should now be reassembled and all bolts and screws tightened. Bus support bolts should be reinserted through both side sheets. Incoming and outgoing connections should be made for both the main power circuit and all control circuits.

### Covering Bus Joints

Bus bars are covered with a flame retardant insulation having a sufficient thickness to stand full line voltage for the rating of the switchgear. Straight joints as well as connections to usual switchgear components are covered by a molded boot. After the bus has been re-assembled at a shipping split, the boot, which is flexible, should be spread apart and slipped over the joint in the same manner as those previously applied in the factory. The flanges should then be fastened together with nylon screws. With this cover no wrapping or filling compound is required, since it fits tightly over the bus insulation.

Tape and sealer are used where bus work runs into apparatus mounted in the switchgear such as flexible connectors, or equipment with irregularly shaped connections. Sufficient quantities of tape and sealer are provided for covering connections to be made in the field. The procedure for applying is as follows:

1. Tighten up hardware. For  $\frac{1}{2}$ " hardware use a torque of 30 to 45 ft. lb.
2. Clean the area to be covered by removing grease, oil or dust.
3. Prepare the bare joint for taping by first providing a smooth, tapered surface for the tape. Use the sealer, carefully eliminating voids and covering bare parts. In no case extend the sealer more than  $\frac{3}{8}$ " onto the bus insulation.
4. Wrap the joint using the tape furnished for the purpose. On 7.5HK or 15HK switchgear wrap 13 half-lapped layers; on 5HK equipment wrap 5 half-lapped layers. Wherever possible have the tape overlap the bus insulation by at least  $1\frac{1}{2}$ ". Half-lapped layers of tape should be "pencilled". Leave no voids between sealer and tape, or between layers of tape.
5. Taping should not cover more than 10% of porcelain bushings or insulators, nor should be carried beyond the first depression or petticoat.

### CONNECTION OF PRIMARY CABLES

In general, there are three common methods of making primary cable entrance connections.

#### Synthetic Covered Cable with Clamps

For this type cable, prepare for entrance to connection lugs, and securely tighten lug clamps. The cable should be prepared as specified by the cable manufacturer. Use sealer and tape as described in previous section.

#### Lead Covered Cable with Wiping Sleeve

When cable diameters are specified on order, the

wiping sleeves are furnished cut off to fit the cables. Uncut wiping sleeves are fitted to the cables as follows:

Wrap a cord (or tape) around the cable to obtain the circumference. Then wrap the cord around the wiping sleeve cone and mark the cone slightly above the cord. Saw off cone. Ream sharp edges of cone with round file.

Wiping sleeves are furnished untinned unless tinning is specified. Sleeves should be freshly tinned by applying flux and dipping in hot solder.

When installing the wiping sleeve, the lead sheath should extend into the sleeve fitting for one inch minimum. The end of the sheath should be belled over and if required by the operating voltage, a stress relief cone applied.

To wipe the joint, scrape the lead sheath clean approximately three inches beyond the end of the cone. Apply stearine flux to the cleaned sheath and to the cone. Then make the wiped joint in the usual manner. Fill wiping sleeve with the compound supplied.

#### Lead Covered Cable with Pothead

The same method of fitting as for wiping sleeves can be used to fit the pothead wiping sleeve to the cables. In the case of the pothead with wiping sleeve, the lead sheath should extend into the pothead for one inch minimum, bell over the end of the sheath, and add a stress relief cone if required. Clean the sheath about three inches beyond the end of the cone and apply stearine flux to end of the cone and the sheath. Wipe the joint in the usual manner.

On inverted potheads, the lead sheath should be extended down into the pothead body beyond the wiping sleeve flange joint so that the sheath will terminate below the level of the compound. To vent the top end of the inverted pothead sleeve while compounding, wipe the joint with a greased wire inserted between the sleeve and the sheath. Pull out the wire to provide a small hole to vent the air. After the pothead has been filled with compound, seal the hole with solder.

#### Shielded Cable

When shielded cable is connected to any terminator, proper stress relief cones must be applied.

### ROOF BUSHINGS

Roof bushings, for cable entrance, are shipped detached from the housing, and must be mounted in place when the switchgear is installed. Each bushing is furnished with a gasket that must be properly inserted between the roof and the bushing flange, using the adhesive as a binder between each of the parts. Cement the gasket to the roof using one layer of adhesive, then spread cement on the remaining flat surface of the gasket. Now put the bushing in place and bolt to the structure. Apply a bead of sealer to the exposed edge of the gasket to provide a weathertight seal.

### CONNECTION TO GROUND BUS

Ground bus bars are bolted to the frames of the housings at the factory before shipment. When housings are shipped separately, it is necessary to bolt the ground bus to the framing. Ground bus bars should be solidly



and permanently connected to the station ground by means of a cable or bus of cross section not less than that of the housing ground bus.

Cable or bus should not be in conduit, and should take the most direct path.

### CONNECTION TO CONTROL SOURCE

The control source wiring to the switchgear should be of larger cross section than the balance of the control wiring in order to reduce the voltage drop, particularly when this source is some distance from the switchgear. Provision is made in the switchgear, in the form of heavy duty terminal blocks, for the connection of these control source leads. The leads should first be checked for proper electrical sequence before the connection is made.

### Secondary and Control Connections

All secondary and control connections on metal-clad switchgear are factory wired in accordance with the connection diagrams applying to the installation. The secondary and control connections for all outgoing connections are wired to terminal blocks accessible to the conduit connections.

Control connections between housings are provided through openings in the side sheets of the switchgear. When shipment is made in groups of several units each, the cross connections between groups are installed at the factory, one end of each of the group connectors is then disconnected and tagged. Care should be taken to insure that all these connections between groups are securely remade when the groups are placed together again.

### INSTALLATION OF BUS BAR CONNECTION BETWEEN GROUPS

The main bus in each group is assembled in the factory complete, ending at the tap connections located at either end of the group. Sections of main bus for connection between groups are provided for installation in the field.

All contact surfaces at all bolted joints in the bus are silver plated. These contact surfaces should be cleaned and then bolted together. Conductivity of a bolted or clamped joint depends upon the pressure applied. The contact surfaces may be cleaned by first rubbing lightly with fine steel wool, then wiping with cloth saturated with carbon tetrachloride. Take care not to remove silver plating.

After bolting the sections of the main bus at junction point of shipment groups, insulate the connections by taping or installing a molded boot over the joint.

For instructions on taping, see section titled "ASSEMBLING THE HOUSINGS."

### TESTING AND INSPECTION

With the housings erected, assembled, and connected, observe the following precautions:

1. Remove all extraneous matter and see that all internal parts are free of dirt, grease, and moisture. If moisture has penetrated, dry out with air or heat.

2. Remove all blocks in relays used for protection in shipment.

3. Apply potential tests to check for any damaged insulation.

60 CYCLE, RMS, WITHSTAND VOLTAGES (1 MINUTE)		
Rated	Factory Test	Field Test
60 volts	500 volts	375 volts
61 to 220 volts	1500 volts	1100 volts
221 to 600 volts	2200 volts	1650 volts
4800 volts	19,000 volts	14,600 volts
7200 volts	36,000 volts	27,000 volts
13,800 volts	36,000 volts	27,000 volts

**CAUTION: IF PHASE TO PHASE TESTS ARE MADE IN ADDITION TO PHASE TO GROUND TEST, CARE MUST BE TAKEN THAT NO SHUNT CONNECTED COILS SUCH AS POTENTIAL TRANSFORMERS ARE CONNECTED DURING THE TESTS.**

4. Check continuity of all circuits. A great deal of this work can be done after the circuit breakers are installed by energizing the control source and operating the equipment with the main circuit dead. Indicating instruments check the continuity of current transformer and potential transformer circuits after the main circuit is energized.

5. Set all relays, regulators, and other devices for proper operation of loads. No relays are set at the factory. Remove screws from short circuiting strip on terminal blocks in current transformer circuits. Screws should be stored in tapped holes in corners of the blocks.

6. If finish has been marred during shipment or installation, apply touch-up paint (which may be secured from the factory).

**IMPORTANT: PROPER PHASING OF ALL MAIN CIRCUITS SHOULD BE CHECKED ACCORDING TO DIAGRAM.**

### FINAL INSPECTION

After the switchgear together with the apparatus which it is to control has been installed and all interconnections made, it should be given a final check and test before being put into service. This is necessary to insure that the equipment has been correctly installed and that all connections are completed. Extreme care must be exercised to prevent the equipment to be controlled from being connected to the system while the preliminary tests are being conducted.

If disconnecting switches are not part of the apparatus or switchgear, the line leads should be disconnected to accomplish this. The testing equipment required will depend entirely on the type of installation. Portable voltmeters both a-c and d-c with a wide range of scales will usually be required. If the equipment to be put into service is quite extensive and complicated, both a-c and d-c ammeters should be available in case unexpected trouble develops.

Some simple portable device for ringing or lighting out circuits should be included in the testing equipment.



## STANDARD CONSTRUCTION

### SHUTTERS

Shutter arrangement shown in Fig. 6 is the means of covering the live terminals of the primary circuit of the switchgear when the circuit breaker is removed from the housing.

The shutters open when the circuit breaker is installed in the housing. The breaker going into the housing engages the arm connected to one of the shutters, and actuates it, opening the shutters as the element continues into the housing toward the "CONNECTED" position.

Check shutter operation by actuating the arm connected to the shutters to see that it does not bind.

### BUS INSULATION

All primary bus work in the housing, with the exception of the ground bus is covered either with I-T-E standard insulation or sealer and tape. The insulation with boots over the joints is used for the main bus, risers and most connections. Sealer and tape are used for joints where boots are not adaptable.

### PRIMARY DISCONNECT DEVICE

Each primary terminal of a drawout circuit breaker is equipped with a disconnect device consisting of a circle of fingers compressed by a garter spring (see Fig. 7). The

mounting of these fingers on the circuit breaker permits inspection of them when the circuit breaker is withdrawn. This is a high pressure, self-aligning device, whose parts are silver plated to reduce the resistance to a minimum. The springs are outside the current path.

The tubular stationary element is rigidly mounted in an insulating molding located in the primary housing of 5HK switchgear and in a porcelain insulator in that of the 7.5 and 15HK switchgear.

### SECONDARY DISCONNECTING DEVICES

All circuit breakers are provided with separable disconnecting devices of the self-aligning pressure-type as shown in Fig. 8. These devices are amply proportioned for carrying the required amount of current. The flexible member of the device is mounted on the breaker frame to facilitate inspection and maintenance. These devices make contact in the fully connected and test position, and no test jumper is needed.

### GROUND BUS AND CONTACTS

The extension of the ground projecting toward the front of the housing, between the floor guides, is shown in Fig. 6. The ground bus contacts are located on the bottom of the rear structure of the circuit breaker and engage the ground bus extension when the breaker is in the connected, test, and any intermediate position.

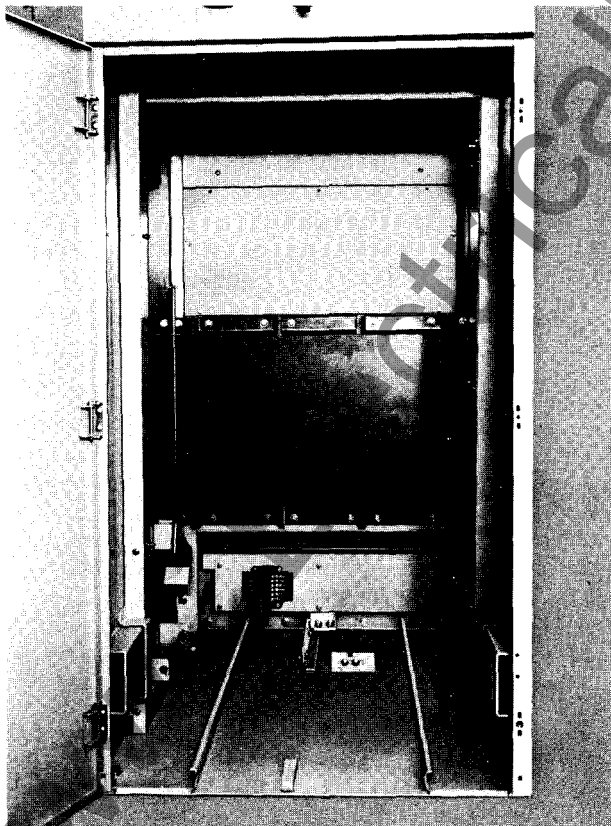

Fig. 6—Front View of Housing

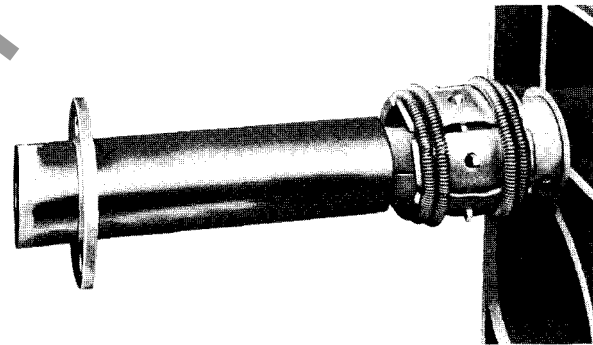

Fig. 7—Primary Disconnect Device

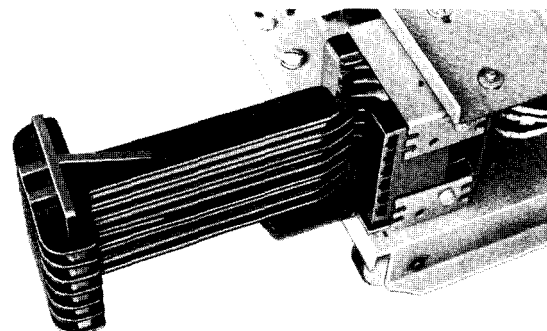

Fig. 8—Secondary Disconnecting Device





## CONTROL WIRES

The main control leads are mounted in the rear of the metering compartment. All electrically operated equipment is connected to these control wires through a suitable control circuit protective device. See Fig. 9.

## CIRCUIT BREAKERS

### GENERAL

Circuit breakers are boxed and shipped separately and without parts of the breakers being blocked or wired for shipping protection.

On each switchboard all circuit breakers of like rating are interchangeable unless the secondary (control) circuit requires otherwise. In these cases interlocking will be used to prevent interchangeability.

Circuit breakers and housing are each set in a jig at the factory.

Circuit breakers have three positions in the housing. In the "DISCONNECT" position the main disconnecting devices on the breaker are disengaged and separated a safe distance from the stationary part of the devices located on the housings. An insulating shutter covers the openings to the stationary part. In this position, all control contacts are disengaged. In the "TEST" position, also, the main disconnecting devices are disengaged and the shutters are closed, but certain of the control contacts are connected so that the circuit breaker may be operated.

In the third or "CONNECTED" position, the main disconnecting devices are engaged, the shutters are open and all control contacts, except those connected to the push buttons on the breaker, are connected.

Interlocks prevent moving a circuit breaker from one position to another unless the breaker is open, and prevent closing the breaker between positions.

For handling of circuit breakers, for the procedure of inserting them into the switchgear compartment and removing them, refer to the separate bulletin covering the breakers.

## HOW TO PUT THE SWITCHGEAR IN SERVICE

### GENERAL

Before energizing the switchgear observe that:

1. The board is completely assembled with all barriers in place, all joints taped and all extraneous material has been removed.
2. Potential tests have been made to determine that all insulation is in good condition.
3. All outgoing cables are either permanently connected or thoroughly insulated so as not to cause a fault, especially at end remote from switchboard.
4. All screws are removed from short circuiting strips on current transformer circuit terminal blocks, and relays are not blocked.
5. All circuits are properly phased.
6. There is a backup circuit breaker which is in operating condition and set so as to clear any fault that inadvertently may occur.

### SAFETY PRECAUTIONS

THE CIRCUIT BREAKERS SHOULD BE IN TEST POSITION WHEN PRACTICABLE. WHEN A THOROUGH INSPECTION OR WORK IS REQUIRED ON A BREAKER, IT MUST BE REMOVED FROM THE HOUSING. THE BUS SHOULD BE DE-ENERGIZED AND GROUNDED WHENEVER POSSIBLE WHEN WORK IS TO BE DONE ON SWITCHGEAR.

### PROCEDURE

All circuit breakers should be in the disconnect position initially. Then first energize the control circuit with the main power circuit de-energized. Rack one circuit breaker into the test position. The charging of the closing springs will indicate that the control power is connected. Then rack the remaining circuit breakers into test position, one at a time.

With the circuit breaker in the test and connected position, open and close the breaker by push buttons when provided on the breaker, or from the control switch, or any remote operating point that may be provided. The breaker may be tripped by manually manipulating all relays and protective devices. Interlocks and special controls may be checked for proper operation.

The main power may now be applied to the switchgear after all circuit breakers have been placed in the test position. Close all doors to the switchgear as a safety measure. Those breakers necessary to energize the main bus should be moved to the connected position and closed. Observe undervoltage relays or other devices that should function properly when the main bus is energized. Next move each circuit breaker in turn to the connected position and close. Observe that all relays and instruments are functioning properly. Improper readings of wattmeters, power factor meters, and watt-hour meters usually indicate improper phasing of meter wiring.

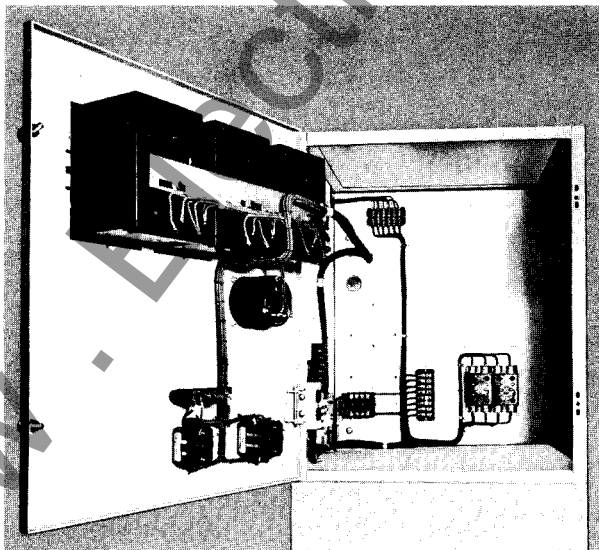

Fig. 9—Control Wires Mounted in Rear of Compartment



When a switchgear installation is fed from one or more generators, it is usual to bring each generator up to speed and connect it to the bus so as to make adjustments on it for speed and voltage. The generators are then synchronized and adjusted for load division.

When a switchgear installation controls synchronous or induction motors, there may be special adjustments of relays and control devices that must be made for the proper operation of the motors.

## MAINTENANCE

### GENERAL

All switchgear installations should be given a general inspection at frequent intervals. Perform a visual inspection, front and rear, to see that there is no evidence of loose parts, warping or undue vibration. Take steps to remedy any deficiencies of this nature that may appear. Keep the assembly dry at all times. If leaks from overhead pipes and dripping from condensation or other sources cannot be eliminated, prevent the moisture from falling on the gear.

### SEMI-ANNUAL INSPECTION

At least twice yearly, a thorough inspection of the board must be performed. Prior to this inspection, deenergize all circuits. The following checks in particular are emphasized:

1. Inspect all bolted connections, nuts and screws for tightness.
2. Inspect all cables for tight connections and ample support.
3. Inspect control wiring for signs of wear and damage. Replace wires wherever doubtful.
4. Examine resistors and other devices prone to overheating.
5. Open all hinged panels and remove all bolted panels.

6. Clean all insulation thoroughly.
7. Withdraw all drawout components and clean. (Refer to Circuit Breaker Instruction Bulletin before cleaning circuit breakers.)
8. Clean the stationary portion of the switchgear by wiping with a clean cloth. A compressed air hose will be useful in the relatively inaccessible areas.
9. Remove covers of all panel devices where practicable. Check wiring for secure connections. Clean contacts on relays and switches wherever necessary. Replace covers.
10. Replace all panels and components.

### CARE OF FINISH

The exterior finish used on I-T-E Switchgear is of the highest grade baked synthetic enamel. The interior frame work is also bonderized and finished with oven baked enamel. The switchgear should be kept clean at all times. Wiping with a clean dry cloth will usually suffice. To remove oil and grease marks, use warm water and soap, wiping dry with a soft cloth.

To touch up the interior finish after final erection, use DuPont Air Dry Gray Enamel. The color finish furnished on the exterior varies, and this information is stated on the front sheet of the Switchgear Bill of Material. To touch up the exterior, use DuPont Duco of the corresponding color.

### RENEWAL PARTS

The quantity of renewal parts to be stocked varies with the installation. Previous experience and the number of units in service are the best guides available. To order replacement parts, contact the nearest Sales Office of the I-T-E Circuit Breaker Company. Give a complete description of the parts and the nameplate data of the device requiring these parts. Specify the quantity required.

WWW.ElectricalPanels.com



[www.ElectricalPartManuals.com](http://www.ElectricalPartManuals.com)

---

## Consult Our Sales Offices

---

The I-T-E Circuit Breaker Company is represented in all principal cities of the United States and Canada. These representatives are experienced and are competent to make correct applications, as well as give complete information and prices. We suggest you consult the representative nearest you.



# I-T-E CIRCUIT BREAKER COMPANY

SWITCHGEAR DIVISION

1900 HAMILTON STREET, PHILADELPHIA, PENNSYLVANIA