

INSTRUCTIONS

GEH-1830A
SUPERSEDES GEH-1830



LOW VOLTAGE DRAWOUT SWITCHGEAR

Type AKD

SWITCHGEAR PRODUCTS DEPARTMENT

GENERAL  ELECTRIC

PHILADELPHIA, PA.

CONTENTS

	PAGE
INTRODUCTION	3
RECEIVING, HANDLING AND STORAGE	3
RECEIVING	3
HANDLING	3
STORAGE	3
DESCRIPTION	7
FRONT ENCLOSURE	7
REAR ENCLOSURE	8
REMOVABLE BREAKER ELEMENTS	9
BREAKER RACKING MECHANISM	9
PRIMARY DISCONNECTING DEVICES	9
SECONDARY DISCONNECTING DEVICES	9
BUS STRUCTURE	9
CONTROL POWER TRANSFORMERS	9
CURRENT TRANSFORMERS	9
POTENTIAL TRANSFORMERS	9
FUSES	10
KEY INTERLOCKS	10
ACCESSORIES	10
Extension Hinges	10
Breaker Lifting Device	10
Maintenance Closing Handle	11
Test Cabinet	11
INSTALLATION	11
LOCATION	11
PREPARATION OF FLOOR ANCHORING	11
Indoor Equipment	11
Outdoor Equipment	11
ASSEMBLY OF EQUIPMENT	11
COMPONENTS	13
SHIPPING SPLITS	13
Indoor Equipment	13
Outdoor Equipment	13
CONNECTIONS	13
Bus Bars	13
Control Cables	13
Ground Bus	13
Main Cables and Supports	13
BREAKER LIFTING DEVICE	14
KEY INTERLOCKS	14
REMOVABLE BREAKER ELEMENTS	14
TEST CABINET	18
ADDITION OF UNITS TO EXISTING EQUIPMENTS	18
TESTING AND INSPECTION	18
MAINTENANCE	19
Annual Maintenance Procedure	19
Fungicide Treatment	19
Outdoor Acrylic Paint Finish	19

LOW VOLTAGE DRAWOUT SWITCHGEAR

TYPE AKD

INTRODUCTION

Type AKD Low Voltage Drawout Switchgear is factory assembled indoor or outdoor equipment utilizing Type AK Drawout Air Circuit Breakers. It consists of one or more units located side by side and connected mechanically and electrically to form a complete switchgear equipment.

Type AKD switchgear provides for the protection and control of electrical apparatus and power circuits with voltage ratings not to exceed 600 volts AC or 250 volts DC.

The drawout air circuit breakers are easily removable to provide maximum accessibility for maintenance with minimum interruption of service. The switchgear is designed to provide maximum safety to the operator and is enclosed in grounded metal compartments.

When adapted to connect directly to a transformer through a transition compartment or bus duct, the combination of transformer and drawout equipment is termed a Load-Center Unit Substation. This may be either single or double ended;

that is, with a transformer at either end or at both ends, Fig. 1.

Outdoor installations are constructed of basic indoor equipments built into a weather-proof housing, Fig. 2. Space heaters are provided in all outdoor equipments in order to keep the inside temperature a few degrees higher than that outside. This helps prevent condensation and resultant corrosion which might occur. The heaters should be energized at all times. Heaters are also furnished for indoor equipments when it is known that excessive humidity exists at the installation.

RECEIVING, HANDLING AND STORAGE

RECEIVING

Every case or crate leaving the factory is plainly marked with case number, requisition number, customer's order number, front or rear, and when for size or other reasons it is necessary to divide the equipment for shipment, with the unit number of the portion of the equipment enclosed in each shipping section.

The contents of each package of the shipment are listed in the Packing Details. This list is packed in one of the cases and forwarded with the shipment. This case is especially marked and its number can also be obtained from the Memorandum of Shipment. When unpacking, to avoid the loss of small parts, the contents of each case should be carefully checked against the Packing Details before discarding the packing material. Check Memorandum of Shipment for shortages, as occasionally the main equipment may be shipped less certain devices. This arrangement enables the purchaser to proceed with installation of main equipment without delay until shortage items are delivered. Notify the nearest General Electric Company Apparatus Sales Office at once if any shortage of material is discovered other than the shortages listed on Memorandum of Shipment.

All elements before leaving the factory are carefully inspected and packed by workmen experienced in the proper handling and packing of electrical equipment. Upon receipt of any apparatus an immediate inspection should be made for any damage sustained while en route. If injury is evident or indication of rough handling is visible, a claim for damage should be filed at once with the transportation company and the General Electric Company Apparatus Sales Office notified promptly.

Information as to damaged parts, part number, case number, requisition number, etc. should accompany the claim.

HANDLING

The switchgear units when assembled and shipped in groups may be most conveniently handled by a crane. A method of handling indoor switchgear with a crane is shown in Fig. 3. The shipping supports shown are securely bolted to the framework on the top of the equipment, and are to be removed only after the equipment is permanently anchored to the station floor. When a breaker lifting device is furnished the shipping supports must be retained for use as track and lifting device members.

If crane facilities are not available, the equipment may be moved into position by means of construction rollers under the skids provided for this purpose. Caution: Rollers should be used for moving equipment into position only with skids in place, as a direct application of rollers may tear or distort the equipment. Remove all outer crating and skids after the equipment has been moved to the desired location. Fig. 3 also shows how jacks may be applied to handle the equipment when a crane is not available.

Methods of handling outdoor switchgear are shown in Fig. 4. The lifting plates should be removed or reassembled (turned in) after the equipment is permanently anchored, so that passageway at the ends of the equipment will not be obstructed.

Air circuit breaker removable elements are usually shipped separately and

with the breaker in the open position. For recommended handling refer to appropriate breaker instruction book.

STORAGE

If it is necessary to store the equipment for any length of time the following precautions should be taken to prevent breakage, corrosion, damage, or deterioration.

1. Uncrate the equipment.
2. Breakers should be prepared for storage separately. Refer to appropriate breaker instruction book.
3. Cover important parts such as rackout mechanism and moving parts with a heavy oil or grease.
4. Store in a clean, dry, rodent-free location with a moderate temperature and cover with a suitable canvas to prevent dust, dirt, water, or other foreign substances from entering the switchgear.
5. If dampness or condensation may be encountered in the storage location, heaters should be placed inside the units to prevent moisture damage. Approximately 250 watts of heaters per unit are required. On outdoor switchgear this may readily be accomplished by making a temporary power supply connection to the heaters already installed in the equipment.

Remove all cartons and other miscellaneous material packed inside units before energizing any heaters.

These instructions do not purport to cover all details or variations in equipment nor to provide for every possible contingency to be met in connection with installation, operation or maintenance. Should further information be desired or should particular problems arise which are not covered sufficiently for the purchaser's purposes, the matter should be referred to the General Electric Company.

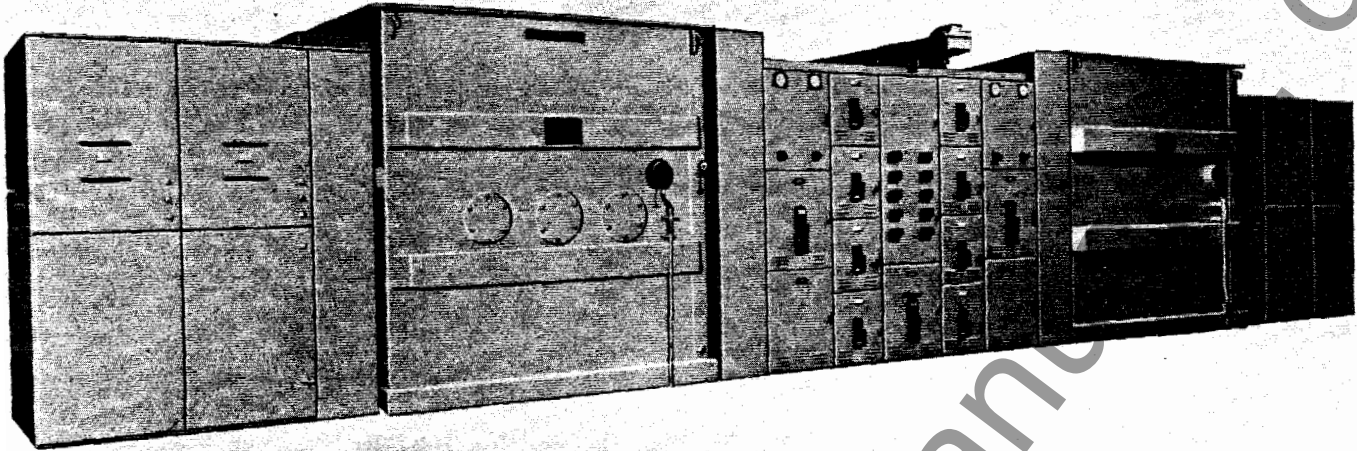

Fig. 1 (8025448)

Fig. 1 Typical Indoor Double-Ended Load-Center Unit Substation With Type AKD Low-Voltage Drawout Switchgear

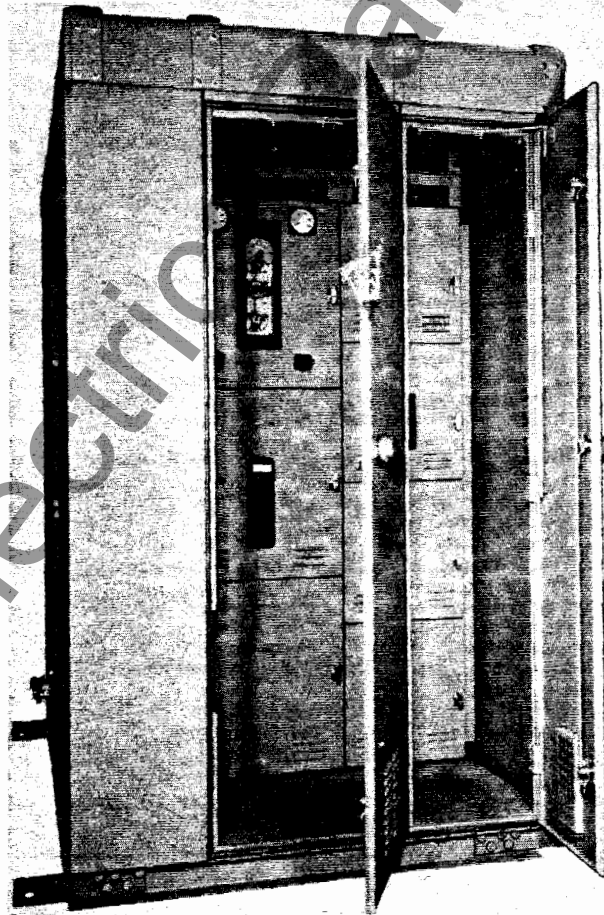
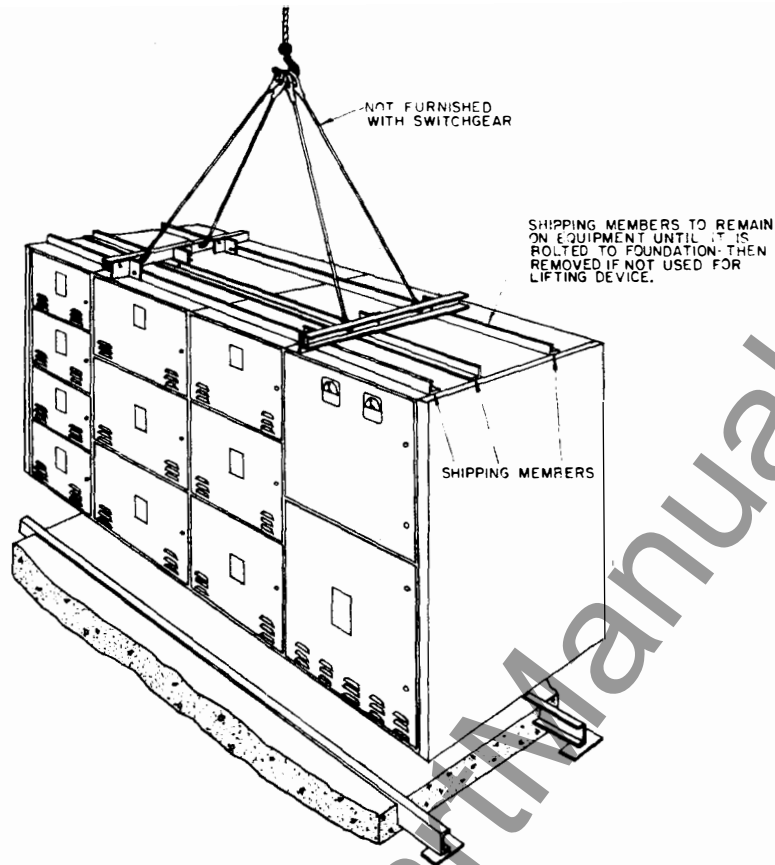

Fig. 2 (8026127)

Fig. 2 Typical Outdoor Type AKD Low-Voltage Drawout Switchgear

Fig. 3 (271B271 Sh.-1)



RECOMMENDED METHOD OF LIFTING

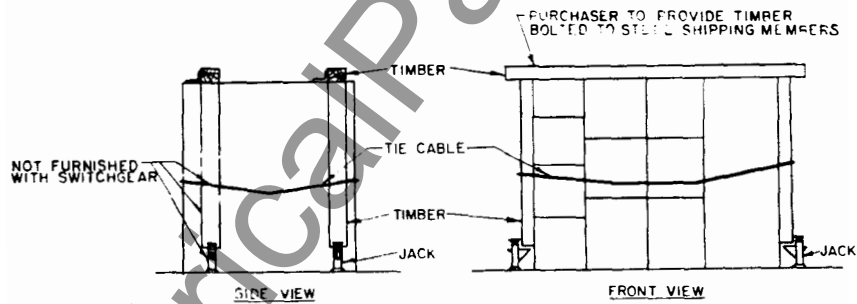

ALTERNATE METHOD OF LIFTING

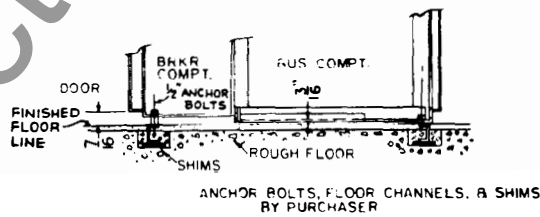

RECOMMENDED METHOD OF ANCHORING

FLOOR STEEL FURNISHED BY PURCHASER UNLESS OTHERWISE INDICATED ON FLOOR PLAN. CHANNELS SHOULD BE SET LEVEL WITH EACH OTHER AND SHOULD BE LEVEL OVER THEIR FULL LENGTH. RECOMMENDED 4 X 5.4 #/FT. CHANNELS TO BE USED FOR LEVELING PURPOSES. FINISH FLOOR SHOULD HAVE SLIGHT PITCH AWAY FROM MOUNTING CHANNELS AND IN NO CASE SHOULD THE FINISH FLOOR BE HIGHER THAN MOUNTING CHANNELS. SWITCHGEAR REQUIRES FLOOR SUPPORT OVER ENTIRE BASE THEREFORE PITCH SHOULD BE MINIMUM.

Fig. 3 Installation Details For Indoor Low-Voltage Switchgear

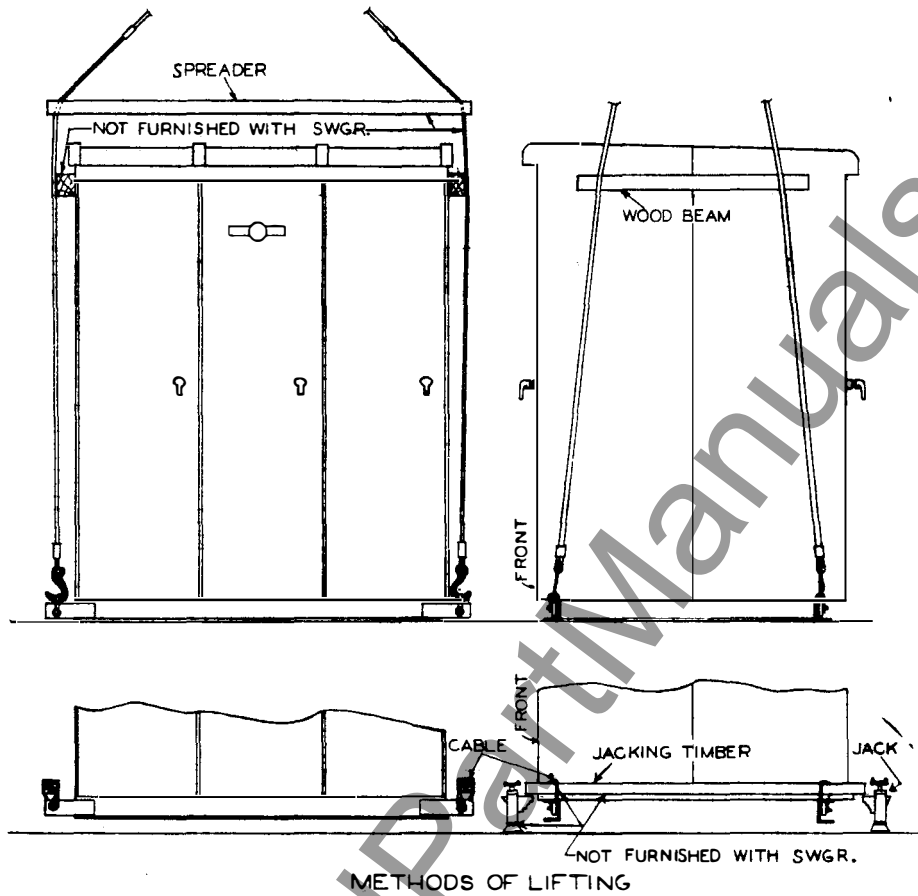

METHODS OF LIFTING

FOUNDATION DATA
 SURFACE 'B' OF CONCRETE PAD SHOULD BE LEVEL.
 IF DESIRED PURCHASER MAY FURNISH AND INSTALL
 FLOOR STEEL 'A' TO FACILITATE THE LEVELING OF THE
 SWITCHGEAR

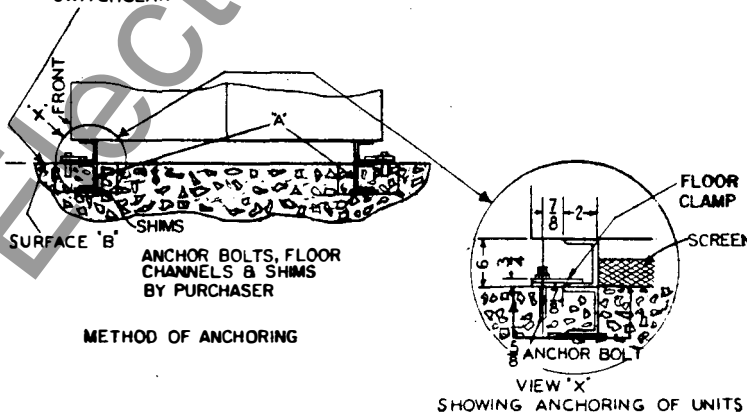

Fig. 4 Installation Details For Outdoor Low Voltage Switchgear

Fig. 4 (271B271 Sh-2)

DESCRIPTION

Each unit is made up of a front enclosure consisting of 1, 2, 3, or 4 front compartments stacked one on top of another, a rear enclosure containing the bus and auxiliaries, and when necessary to adjust the depth of a unit for matching or lining-up to other units, a rear filler enclosure. One or more of these units is combined with two end covers to form an AKD equipment, Fig. 5.

A standard front enclosure for draw-out AK-15 and 25 manual and electrical air circuit breakers will normally consist of 4 compartments stacked on top of each other to form a unit 90 inches high by 20 inches wide. For an AK-50 manual and electrical breaker unit there will usually be 3 compartments stacked to give a 90 inch high by 26 inch wide unit. The

AK-75 will be similar to the AK-50 stack but will be 30 inches wide, and will be limited to two AK-75 breakers per unit. The AK-100 unit, consisting of 2 compartments, measures 90 inches high by 38 inches wide and will be limited to one AK-100 breaker per unit.

All drawout breaker compartments contain drawout features for the breaker element. The AK-15, and -25 breakers have guides which ride a track in the compartment, Figs. 7 and 8. Units housing AK-50, -75, and -100 breakers have a drawout tray at the bottom of each compartment on which the breaker element rides, Figs. 9 and 10.

FRONT ENCLOSURE

The front enclosure, Fig. 6 consists of circuit breaker and instrument compartments of the same width and depth

Fig. 5 (8014265)

Fig. 6 (8028115)

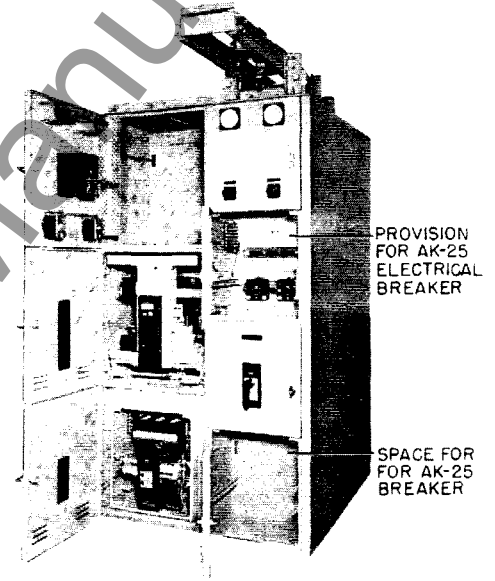
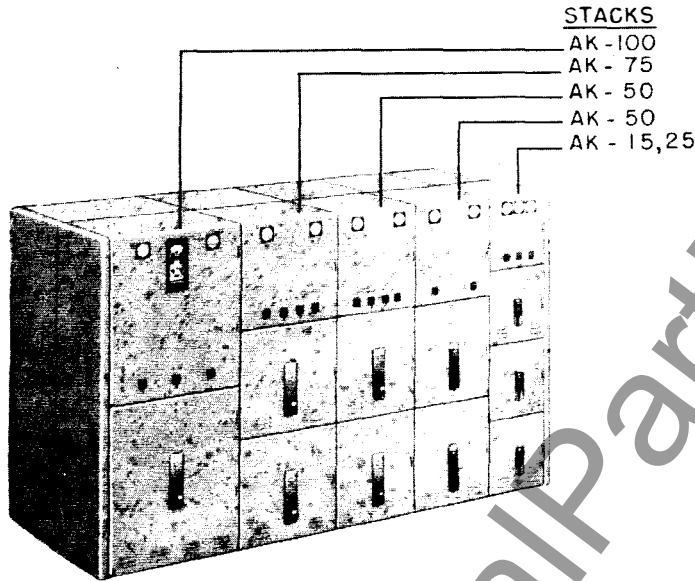

Fig. 5 Typical Indoor Type AKD Low Voltage Switchgear

Fig. 6 Type AKD Low Voltage Drawout Switchgear - Front Enclosure

Fig. 7 (8023849)

Fig. 8 (8028184)

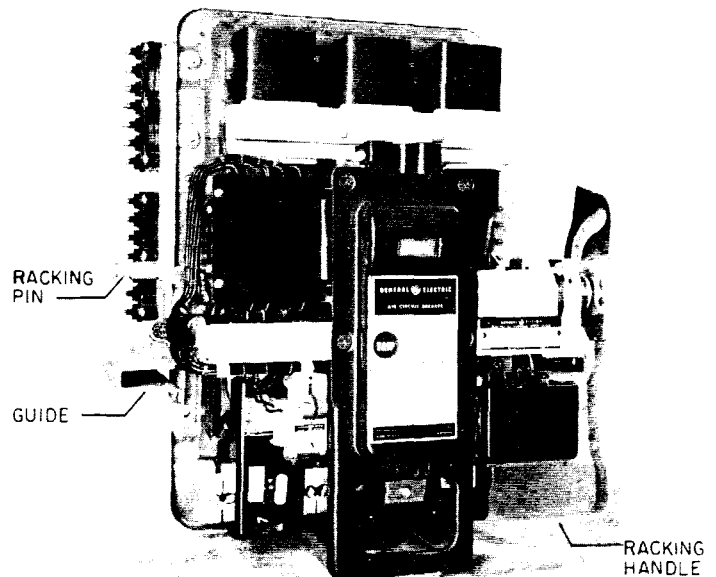
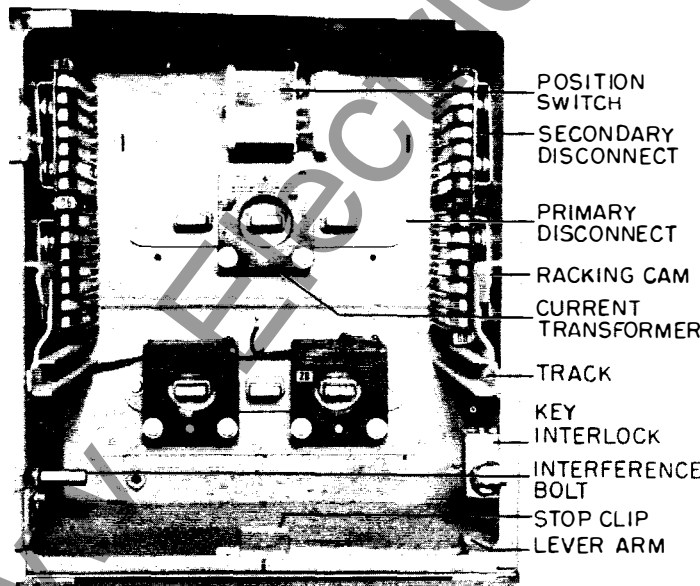

Fig. 7 Internal View of AK-25 Drawout Breaker Compartment

Fig. 8 Electrically Operated Drawout AK-25 Air Circuit Breaker

All drawout breaker compartments also have a positive stop with manual release to hold the breaker in the "Test" position and a limit stop for the "Disconnected" position. The AK-15 and -25 compartments have a stop clip, Fig. 7 with a lever arm. The clip catches on the breaker element and stops it from further movement outward until the lever arm is raised to release the clip, then the element can again move outward. The AK-50, -75, and -100 compartments use a catch mounted on the drawout carriage which engages a cam on the bottom of the housing for the "Test" position, Fig. 9.

Every drawout breaker compartment contains a means for grounding the breaker element. The AK-15 and -25 breakers are

grounded through the plated guides on the sides of the breaker element to the plated track in which the guides ride, Figs. 7 and 8. These tracks are welded to the breaker compartment. The AK-50, -75, and -100 compartments each contain a ground shoe, Fig. 9, which is mounted on the side of the breaker compartment. The breaker element contains a ground pad, Fig. 10, which makes contact with the ground shoe in the compartment.

Secondary disconnects and a position switch, as required, are provided for control and electrical interlocking of electrically operated air circuit breakers. The position switch, Figs. 7 and 9, is actuated when the breaker is racked into the "Connected" position. The switch contacts

return to normal when the breaker is in the "Test" or "Disconnected" positions.

REAR ENCLOSURE

The rear frame, Fig. 12, consists of welded sub-assemblies bolted together to form a rear frame structure. This structure contains bus and bus supports, potential and control power transformers, fuses, terminal blocks, control wiring and troughs, etc.

Rear frames are constructed similarly and are of equal depth. When smaller breaker units line up with larger breaker units a filler compartment is installed between the front enclosure and the rear frame to give the proper depth.

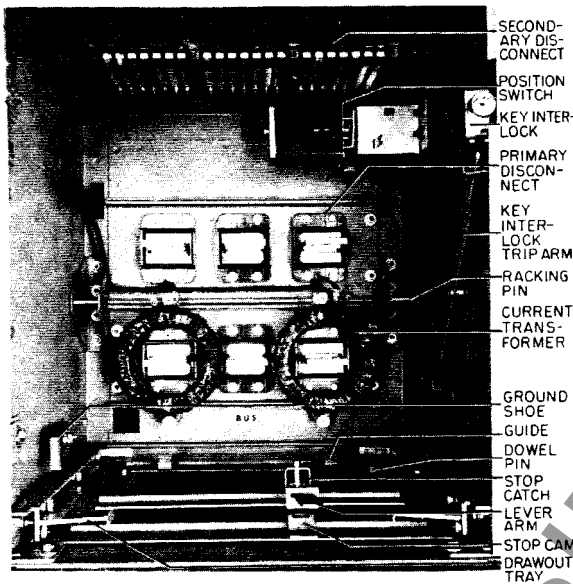

Fig. 9 Internal View of AK-50 Drawout Breaker Compartment

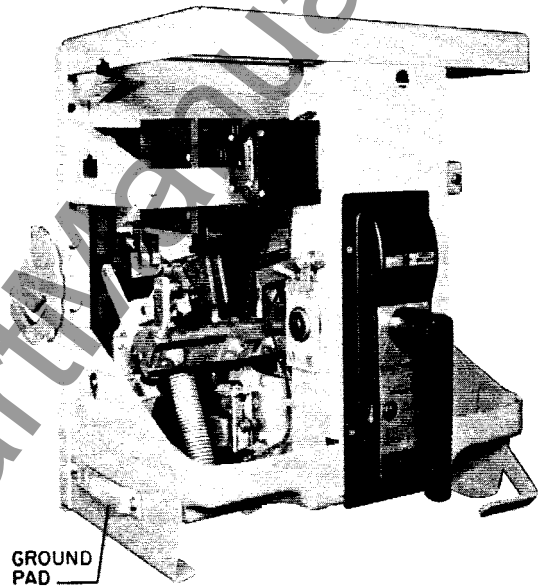

Fig. 10 Left Front Oblique View of Drawout AK-50 Manual Air Circuit Breaker

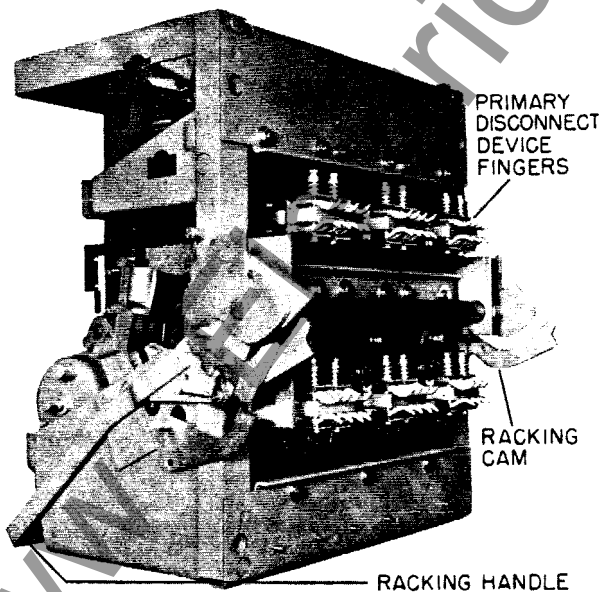

Fig. 11 Right Rear Oblique View of Drawout AK-50 Electrical Air Circuit Breaker

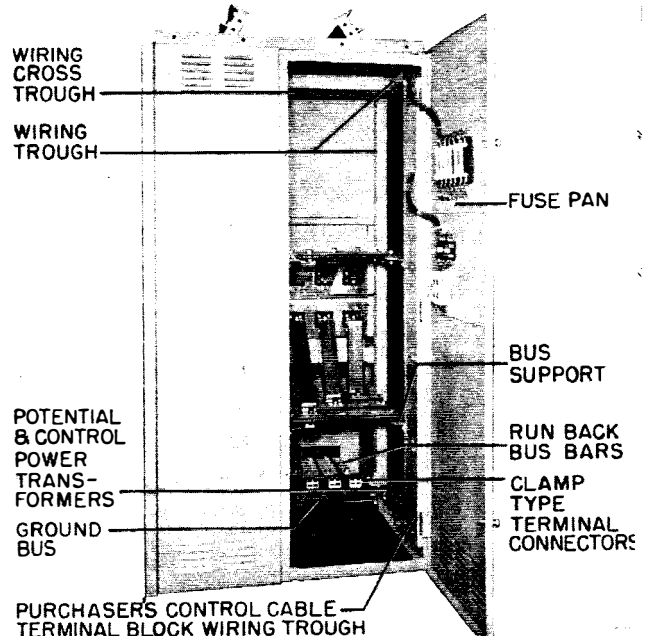

Fig. 12 Rear Enclosure of Drawout Switchgear Units

Fig. 9 (8023690)

Fig. 10 (8026807)

Fig. 11 (8028207)

Fig. 12 (8025875)

REMOVABLE BREAKER ELEMENTS

The type AK removable breaker element consists of an interlock mechanism, the movable portion of the primary and secondary disconnecting devices, the breaker closing and tripping devices, the required protective devices, and all the necessary control wiring. The breaker element is equipped with a positive mechanical interlock which prevents the breaker from being racked in or out of the "Connected" position until after the breaker is tripped open. This interlock also holds the breaker trip-free and prevents the breaker from being closed while it is being racked in or out of the "Connected" position.

Each of the type AK-15 and 25 draw-out circuit breakers is equipped with a drawout carriage, Fig. 8. The drawout carriage is a supporting frame which is equipped with primary and secondary disconnect devices, racking handle and mechanism, positive mechanical interlock, and horizontal guides for supporting the breaker element and carriage in the housing. On the bottom of the carriage are slots for engaging the breaker position stop clip and holding the breaker element in either the "Test" or "Disconnected" positions.

The type AK-50, 75, and 100 draw-out breakers fit on a drawout tray which is part of and rides within the breaker compartment Figs. 9 and 10. The draw-out features added to the breaker element are primary and secondary disconnect devices and on the rear vertical frame members of each side of the breaker element are the racking cams with the positive mechanical interlock. These cams are joined by a rod across the back and are operated by a handle on the right side of the breaker element.

All circuit breaker removable elements of the same type and rating which have duplicate wiring may be interchanged.

For complete circuit breaker details, refer to appropriate breaker instruction book.

BREAKER RACKING MECHANISM

The drawout breaker element is provided with a racking device to lock the removable element in the "Connected" position and to overcome the mechanical resistance of making and breaking the contacts

of the disconnecting devices. All racking moving parts are mounted on the removable breaker element to provide easy access for inspection and servicing. The AK-15 and -25 use one type of device. Fig. 8, and the AK-50, -75, and -100 use another type device, Fig. 11. The breaker racking mechanism for the type AK circuit breaker consists of a racking cam Figs. 7 and 11 (on the housing for the AK-15 and -25, and on the breaker for the AK-50, -75, and -100) which operates on a racking pin Figs. 8 and 9 (mounted on the breaker for the AK-15 and -25 and on the housing for the AK-50, -75, and -100).

The racking mechanism is manually operated by an integral racking handle.

PRIMARY DISCONNECTING DEVICES

The primary disconnecting devices, the stationary portions of which are shown in Fig. 13, are used to connect the circuit breaker into the primary circuit. They utilize silver to silver contacts to insure against reduction of current carrying capacity due to oxidation of the contact surfaces. For ratings of 15 to 1600 amperes, these disconnects are of the high pressure finger and bar type with the fingers backed by stiff springs. The fingers are mounted on the removable element as shown in Fig. 11 and the bars are mounted on the stationary element. For ratings of 2000 to 4000 amperes, the stud and tube type is employed, with the tube backed up by heavy garter springs to assure contact pressure. The stud, Fig. 14 is mounted on the removable element, and the tube on the stationary element.

SECONDARY DISCONNECTING DEVICES

Secondary disconnecting devices, shown in Fig. 15, are used to connect the circuit breaker closing motor or coil, trip coil, auxiliary switches, etc. to their external control circuits. These disconnects consist of two parts: (1) The fingers which mount on the removable element, and (2) the slide bar contacts which mount on the stationary element. These devices automatically make contact when the breaker is inserted into the "Test" position, and maintain contact through the "Connected" position. These devices are made in sections of 7 contacts each. All type AK breakers use the same

secondary disconnecting device. The stationary elements of the secondary disconnect device for AK-15 and -25 breakers are mounted vertically on the sides of the drawout breaker compartment, while for the AK-50, -75, and -100 breakers the devices are mounted horizontally at the top.

BUS STRUCTURE

Buses are bare and located within the rear frame structure where accessibility is obtained through full height rear doors. They are rigidly supported on polyester glass compound insulating angles which are resistant to fire and moisture, and have an excellent dielectric and mechanical strength. The bus is constructed with silver plated connection joints to give good contact. Additional current carrying capacity is obtained with a multiple bar construction, where one bar is placed on top of the other with 1/4 inch spacer to allow for ventilation, Fig. 12.

This bus arrangement provides maximum strength characteristics during short circuits. This is accomplished by placing the bus bars edge to edge with their flat surfaces in the same plane. In this way, the strongest section of the bus is used to oppose the stresses set up by short circuit currents.

CONTROL POWER TRANSFORMERS

A control power transformer is used to furnish power for electrically operated circuit breakers, lights, heaters, receptacles, etc. as required. The control power transformer is mounted on a pan support in the rear frame structure, Fig. 12.

CURRENT TRANSFORMERS

Breaker compartments will use window type current transformers which are mounted within the breaker compartment around the primary disconnecting devices, Figs. 7 and 9. Current transformers are also located in the rear enclosure as required.

POTENTIAL TRANSFORMERS

Potential transformers are mounted on a pan support in the rear frame structure, Fig. 12. All potential transformers are separately fused.

Fig. 13 (8023847)

Fig. 14 (8028117)

Fig. 15 (8028116)

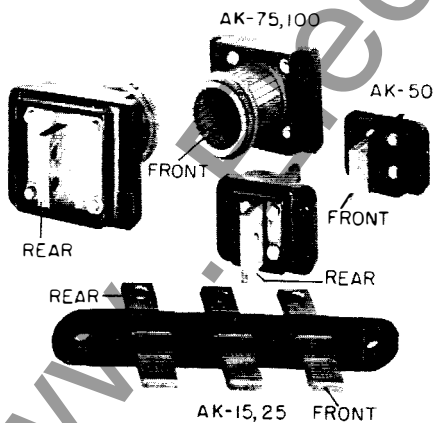

Fig. 13 Stationary Primary Disconnecting Devices For Type AKD Switchgear

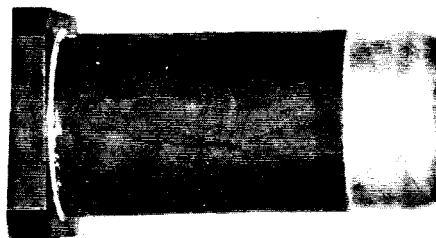

Fig. 14 Stud Type Primary Disconnecting Device Removable Element For AK-75 Breaker

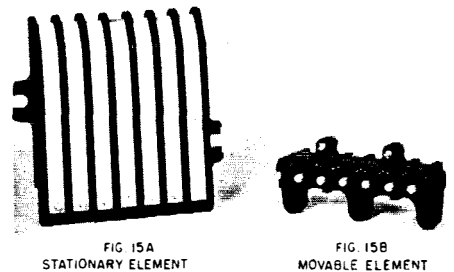

Fig. 15 Secondary Disconnecting Devices For Type AKD Switchgear

FUSES

Fuses for breaker control, potential and control power transformers, etc. are mounted on the inside of the rear door. When replacing blown fuses, refer to connection diagrams furnished with the equipment for recommended fuse ratings.

KEY INTERLOCKS

Key interlocks are generally used on AKD switchgear to provide a simple, safe, and reliable means for mechanically interlocking breakers. Key interlocks are mounted on a bracket on the right hand side of the breaker compartment Figs. 7 and 9.

ACCESSORIES

The following accessories are available to facilitate the installation, operation, and maintenance of this equipment:

Extension Hinges

Extension hinges are available as shown in Fig. 16. They make it possible to close the breaker compartment door when the breaker is in the "Test" position.

Breaker Lifting Device

It is recommended that a breaker lifting device be used for lifting and lowering the breaker removable elements to and from the breaker compartments, Figs. 17 and 18. The lifting device requires no storage

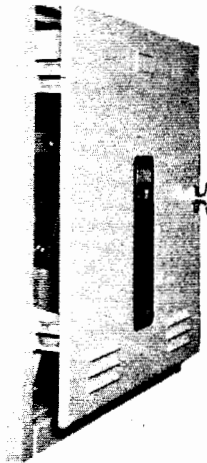

Fig. 16 AK-50 Drawout Air Circuit Breaker In "Test" Position With Door Closed and Hinges Extended

space since it is mounted in an out of the way location on the equipment and may be left in place when not in use. The lifting device travels on angle rails on the equipment structure for easy positioning over any unit.

The breaker lifting device consists of a traveling detachable track, a pair of angle rails, cable hoist, operating handle, and set of lifting spreaders.

Detachables Track has sufficient movement to permit completely withdrawing the breaker from its compartment and lowering it to the floor for inspection, or the breaker can be swung outward as it is lowered to deposit it on a truck in front of the equipment.

Angle Rails are permanently attached to the equipment.

Cable Hoist is fitted with overhanging flanged wheels running on the track. The hoist has self-locking gears and supports the load in any position without the use of a brake or ratchet.

Detachables Handle is equipped with a hook to engage the eye on the end of the worm shaft. The hook and eye attachment of the handle makes it unnecessary for the operator to hold the handle in place and he can devote his attention to guiding the breaker into position.

Lifting Spreaders for attaching to the breaker removable elements when using a breaker lifting device are furnished as required for the different frame size breakers included in the equipment. These spreaders provide a ready method of placing breaker elements in their compartments, and require a minimum of head room.

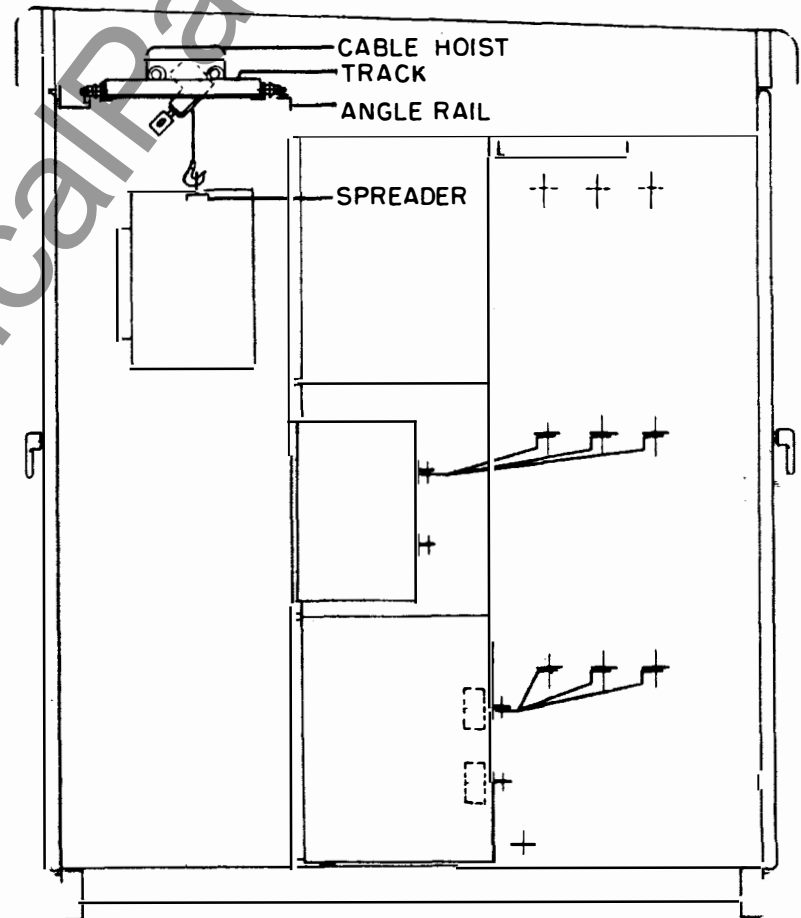

Fig. 17 Indoor Type AKD Switchgear With Breaker Lifting Device

Fig. 18 Cross Section of Outdoor Drawout Unit with Breaker Lifting Device

Fig. 16 (8022393)

Fig. 17 (8028257)

Fig. 18 (0148A2063)

Maintenance Closing Handle

A maintenance closing handle is provided for closing electrically operated type AK breakers when in the "Disconnected" position. It should not be used as a manual device to close the breaker when it is in the "Connected" position. Before this device can be used, the breaker compartment door must be open. For the AK-15 and -25

breakers this device consists of a lever, Fig. 19. For AK-50, -75, and -100 breakers, it is a ratchet type wrench, Fig. 20.

Test Cabinet

A test cabinet is available for electrically opening and closing the breaker when it is removed from its compartment. It consists of a box containing a terminal

block, fuses, control switch, and a cable terminating in a clamp-on coupler which can be quickly attached to the secondary disconnecting device on the breaker removable element. A test cabinet and coupler for electrically operated AK-50, -75, and -100 drawout breakers are shown in Fig. 21. A similar cabinet and coupler are available for electrically operated AK-15 and -25 drawout breakers.

Fig. 19 (8028111)

Fig. 20 (8028113)

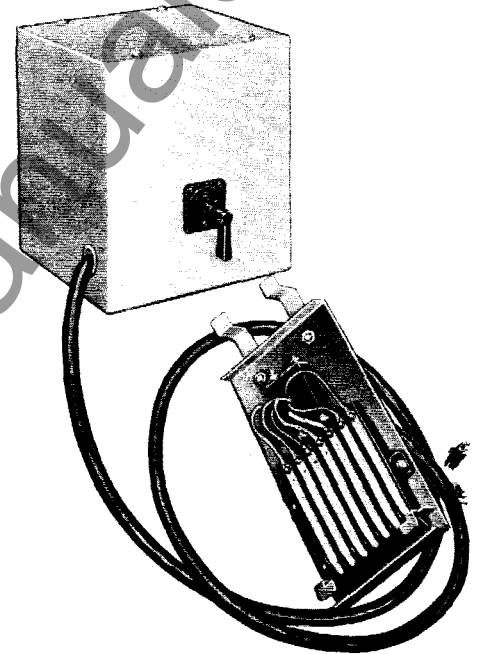
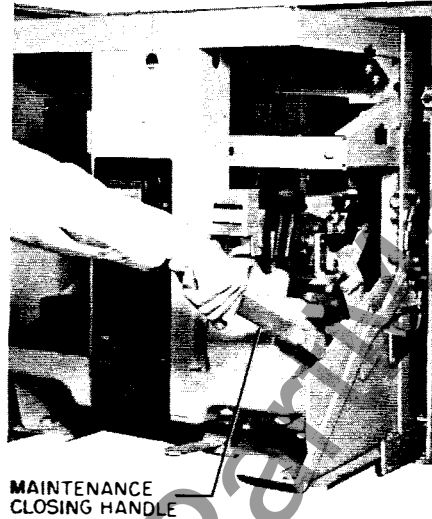
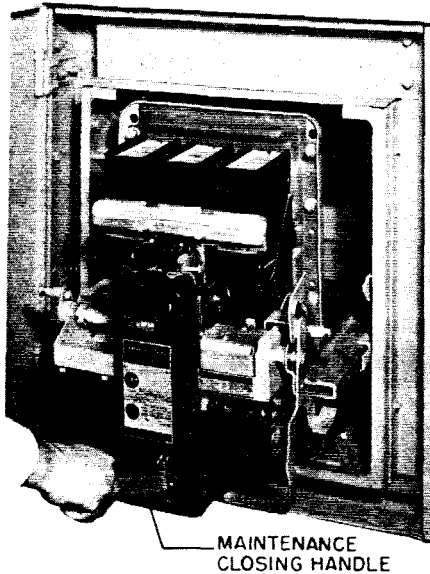

Fig. 19 Manual Closing of Electrically Operated AK-25 Breaker for Maintenance

Fig. 20 Manual Closing of Electrically Operated AK-50 Breaker for Maintenance

Fig. 21 Test Cabinet and Coupler For Electrically Operated AK-50, 75 and 100 Drawout Breakers

Fig. 21 (8019869)

INSTALLATION

Before any installation work is done, consult and study all drawings furnished by the General Electric Company for the particular requisition. These include arrangement drawings, connection and elementary diagrams, and a summary of the equipment. When requesting information from the factory on any specific item furnished with the equipment, refer to the item by summary and mark number wherever possible.

Mats, screens, railings, etc. which are external to the switchgear, but which may be required to meet any local codes, must be furnished by the purchaser.

LOCATION

The recommended aisle space required at the front and the rear of the equipment is shown on the floor plan drawing furnished for the particular requisition. The space at the front must be sufficient to permit the opening of doors, the insertion and withdrawal of the removable elements and their transfer to other compartments, the operation of breakers while in the "Test" position, and the operation of the breaker lifting device. The space at the rear must

be sufficient for opening of doors, installation of cables, inspection, and maintenance. Check local codes for special aisle space requirements.

PREPARATION OF FLOOR-ANCHORING

Indoor Equipment

The station floor must be strong enough to prevent sagging due to the weight of the switchgear structure. If the foundation is subject to vibrations, special mounting should be provided to prevent the transmittal of vibrations to the equipment.

Suitable means must be provided by the purchaser for anchoring the switchgear to the floor. It is essential that the floor be level to avoid distortion of the switchgear structure, and that the equipment be completely aligned prior to final anchoring. The recommended floor construction and method of anchoring is shown in Fig. 3. This information is also sent to the purchaser with requisition drawings. The floor channels must be level and accurately aligned. Steel shims may be used for exact leveling of the switchgear if

necessary. Anchor bolts, if used, must be located according to the floor plan drawing. If desired, tack welds can be substituted for anchor bolts.

Main and control cable conduits should be located in accordance with the available space shown on the floor plan drawing and extend not more than 4 inches above the floor. Consideration should be given to installing conduits which might be required for future connections.

Outdoor Equipment

Foundation recommendations for outdoor equipment are given in Fig. 4. Otherwise comments under **Indoor Equipment** apply.

ASSEMBLY OF EQUIPMENT

Before assembly of the equipment is begun, all components should be on hand so that the work may be completed without delay. When assembling together individually shipped sections start with the middle section. This procedure will insure minimum deviation from overall length dimension.

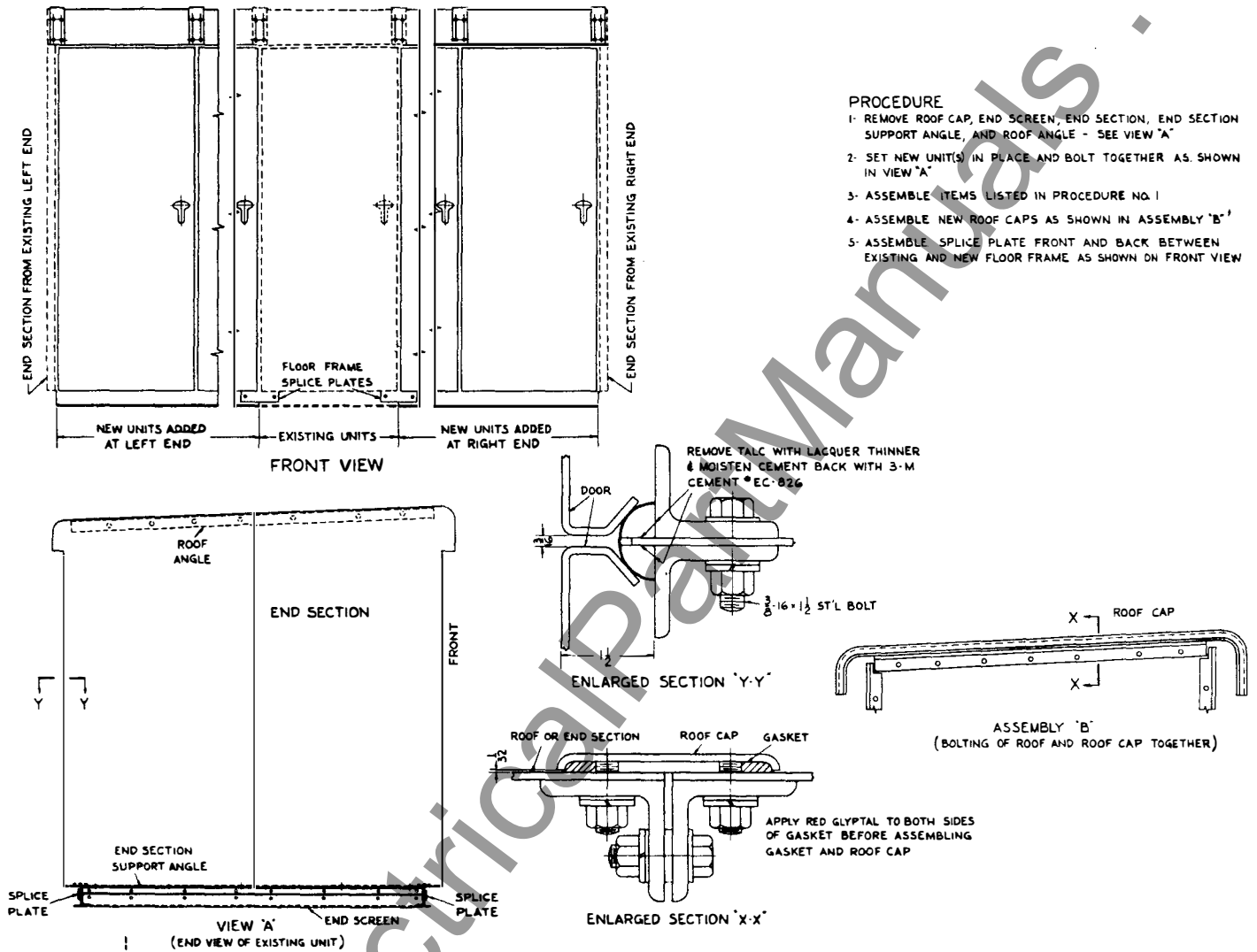

Fig. 22 Installation Details For Outdoor Drawout Shipping Splits

Fig. 22 (0245C0504)

Indoor transition compartments for connecting switchgear equipments to transformers are adapted for easy field disassembly and reassembly. On outdoor equipments the transition must be made weatherproof and therefore is of one piece construction and not adapted to disassembly in the field.

It is imperative that connection bus bars be accurately aligned. Minor adjustments may be made by loosening bars and supports, lining up connections, then retightening.

COMPONENTS

With all components available, the assembly may proceed as follows:

1. If the switchgear is part of a Load-Center Unit Substation, the transformer should be set on its pad.
2. The switchgear should be placed on its foundation with the aid of a crane or jacks as shown in Fig. 3 for indoor equipment and Fig. 4 for outdoor equipment. (Refer to HANDLING)
3. After the switchgear is in place steel shims may be used for accurate leveling.
4. If the switchgear is part of a Load-Center Unit Substation, the connections to the transformer should be made.

(NOTE- When AKD switchgear is installed in the same line-up with transformers and other equipments, it is imperative that all the equipments are level with each other.)

The connection bars in the transition compartment may be shipped turned in to reduce the size of the shipping package and to protect them from damage. These bars should be reassembled as required and connected to the transformer terminals.

The gasket for outdoor transformers is furnished with the transformer while the hardware for connecting bus bars and transformer flange to the switchgear is supplied with the switchgear.

5. The equipment should be anchored to the foundation by anchor bolts or tack welds.
6. The shipping supports should be removed from the switchgear, if not used with a breaker lifting device.
7. Bus ducts and cable conduits should be lined-up and connected to the equipment. Hardware for connecting bus duct to the switchgear is furnished with the bus duct.
8. Check to see that the breakers fit into their compartments.
9. Remove all blocking on relays and devices.
10. Check alignment of doors on outdoor equipment to see that the weatherproof seal has not been disturbed. Doors can be knocked out of alignment during shipment and might require a slight adjustment.

SHIPPING SPLITS

Additional steps are required to assemble the switchgear when it is shipped in more than one section.

Indoor Equipment

After all sections of the switchgear are placed on their foundation, they must be bolted together. In addition to bolting the compartments and rear frames of adjacent sections together, the main buses, ground buses, neutral buses, control cables, etc. must be connected. When bolting together shipping sections it is imperative that the fronts of all sections of the switchgear are lined-up.

To reduce the size of the shipping package, the bus splice bars at the shipping splits are sometimes shipped turned in. These splice bars should be reassembled as required.

Outdoor Equipment

Fig. 22 indicates the special procedures involved in the assembly of outdoor equipment. The joint in the roof between sections must be weather-proofed. Apply G. E. #1201 Glyptal* cement to the gaskets which are furnished, and assemble the gasket between the roof flanges and bolt together. Joints between transformer throat and switchgear, and between splits should be weather-proofed in the same manner. Otherwise, the installation is the same as the Indoor Equipment.

CONNECTIONS

Bus Bars

Where bus bar connections are to be made, proceed as follows:

1. Clean all silvered contacts with silver polish. Do not use sand paper or any other type of abrasive material. Be sure all polish is removed after cleaning.
2. After the contacts are cleaned they should be coated with a lubricant D50H47 furnished with each equipment.
3. Bolt bus bars together with the splice bars as furnished with the equipment, see Table A.

TABLE A

TORQUE VALUES FOR LOW VOLTAGE EQUIPMENT

Aluminum, Compound, Copper, Steel

Bolt Size	Inch-Pounds	Foot-Pounds
3/8"-16	180-240	15-20
1/2"-13	360-480	30-40
5/8"-11	420-540	35-45

Control Cables

1. When control conduits enter the unit from below, the conduit should not extend more than 4 inches above the floor. The control cables may be pulled through the conduits before or after the switchgear is installed, whichever is more convenient.
2. Connect the cables to the terminal blocks in accordance with the connection diagrams furnished for the requisition.
3. Covers on the terminal block wiring trough may be cut back as required to permit access of the control cables into this trough at various heights.

4. If the control conduits enter from above, drill the top cover within the available space indicated. The control conduit should not extend into the unit far enough to interfere with the buses. Adequate electrical and mechanical clearance must be provided between conduits and cables, and buses.

5. Where units have been split for shipment, any control or other secondary leads which must connect across the split will be provided with terminal blocks in the wiring cross trough. These shipping split terminal blocks and associated wiring are made accessible in indoor equipment by removing the top cover plates. In outdoor equipment the wiring cross trough must be unbolted. The wires are cut to length and formed before being folded back for shipment so that they can be readily reconnected.

6. Control wiring should be checked with the connection diagrams to make certain that all remote connections are made, all shortage devices and fuses installed, current transformer circuits completed, loose connections tightened, and insulation meggered before equipment is energized.

7. The cables from the control power source to the switchgear should be large enough to avoid excessive voltage drop when the circuit breakers are operated. See TESTING AND INSPECTION.

8. Control wiring for future current transformers is coiled and tagged in the area equipped with provisions for mounting the future current transformers.

Ground Bus

The ground bus is bolted to the rear of the frame near the bottom. A 4/0 ground connector will be included as standard on each equipment for connection to the station ground. It is very important that the equipment be adequately grounded for safety. Where AKD switchgear is shipped in more than one section, the sections of ground bus must be connected together by using the splice bars furnished with the equipment.

Main Cables and Supports

Before any main cable connections are made, the cables should be identified to indicate correctly their phase relationship with the equipment connections. In all cases carefully follow the cable manufacturer's recommendations for installation of cable as well as instructions contained herein. A non-oxidizing lubricant such as D50H47 furnished with each equipment should be used on the terminal connection surfaces to prevent corrosion.

Main cables can enter from the top or bottom of the rear section of the rear frame, Fig. 23. Adequate electrical and mechanical clearances must be provided between conduits and cables, and buses. If these cables are small (500 MCM and below), or if the number is not excessive, they can be racked to the side of their unit out of the way. If heavy cables are used, they can enter along the back of the unit and be lashed to cable supports at the rear. Cable terminal connectors are included as required.

The purchaser should furnish suitable cable supports and lash cables at each breaker level as required. Cable supports are not required in the bottom compartment of a unit when cables enter from below. However, it is imperative that all cables be adequately supported to take their weight off terminals and studs and to prevent movement during short circuit.

The equipment rear frame is designed to accommodate cable supports on the side frame, or across the rear of the unit, Fig. 23. Sufficient holes are provided in the rear frame to allow cable supports to be mounted in various positions. This permits the location of cable supports for various cable conditions.

BREAKER LIFTING DEVICE

The breaker lifting device, Figs. 17 and 18 runs on rails along the equipment.

All necessary parts and hardware which are not part of the switchgear equipment are shipped in a separate package with complete detailed assembly instructions.

For indoor equipment the angle rails and channels of the breaker lifting device are also used as shipping members. These members are plainly marked and it is imperative that they are not discarded.

Stop clips are also included with the lifting device furnished with indoor equipment which should be mounted by the purchaser at each end of the front rail to prevent running the track off the ends of the rails. Outdoor equipment is furnished with stops which are incorporated into the equipment design.

Indoor Equipment - To place the track on its rails, the front grooved wheels should be held approximately 6 inches above their rail and the back wheels slipped under the rear rail. The front of the track should then be lowered so that the grooved wheels straddle the front rail.

Outdoor Equipment - To place the track on its rails orient the long dimension of the track so that it is parallel with and between the rails and raise it a few inches above the rails. With the track in this position turn it 90 degrees (checking that the front of the track is toward the front of the equipment as shown in Fig. 18) and position the track so that its four wheels are resting on their respective rails.

The hoist can now be set down between the channels of the track so that the four flanged wheels ride on the upper legs of these channels. In this position it is free to roll perpendicular to the face of the switchgear.

KEY INTERLOCKS

Equipment furnished with key interlocks is shipped with the keys inserted in the lock or attached to the equipment near the lock.

After installation it is imperative that all spare keys are removed and placed in the hands of a responsible person. Refer to the key interlock schematic included in the summary furnished with the equipment to determine sequence of operation and the correct number of operating keys required. This precaution is necessary since improper use of spare keys will defeat the interlocking scheme.

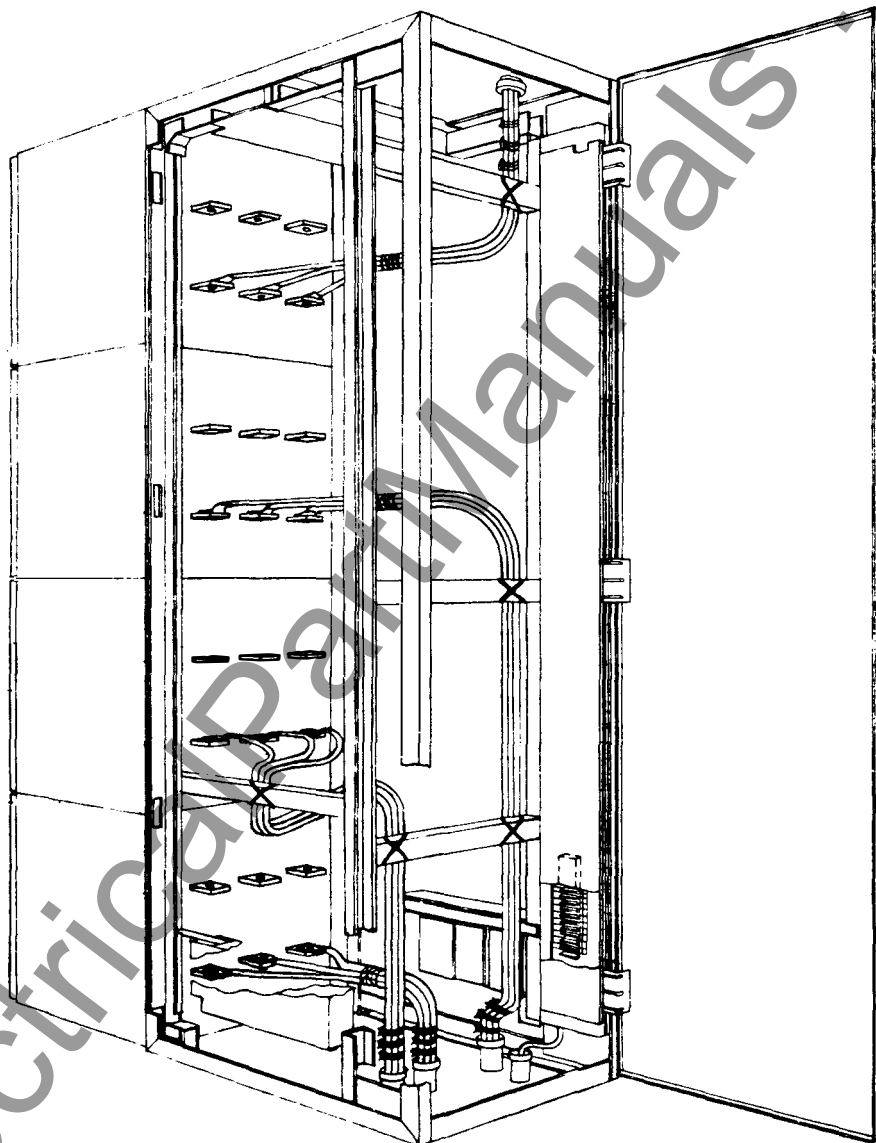

Fig. 23 Low Voltage Drawout Switchgear Bus Compartment Showing Main and Control Cable Connections, Lashings and Cable Supports

REMOVABLE BREAKER ELEMENTS

Before installing or operating the removable element, consult the circuit breaker instructions for directions on installation, adjustments, and inspection. Be sure to first check the element thoroughly for loose parts and dirt or foreign elements in the contacts or mechanism.

For proper alignment of primary and secondary devices refer to dimensions as

shown in Figs. 24, 25, 26, and 27.

An interference bolt is provided to prevent an AK-15 drawout breaker from being inserted in an AK-25 housing, Fig. 7.

Before inserting any breaker into its compartment, wipe clean existing lubricant, and apply contact lubricant, D50H47, on both primary and secondary disconnecting devices. A quantity of this grease is shipped with each equipment.

Fig. 23 (089180600)

Fig. 24 (8023817)

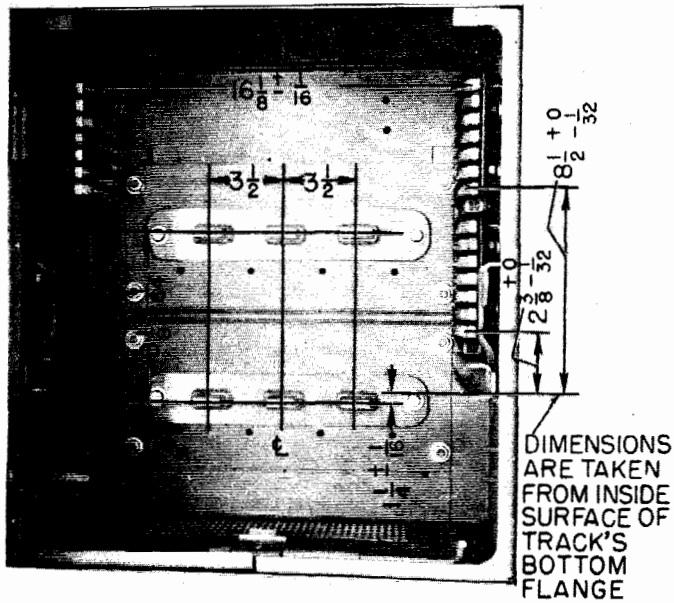

Fig. 25 (8024329)

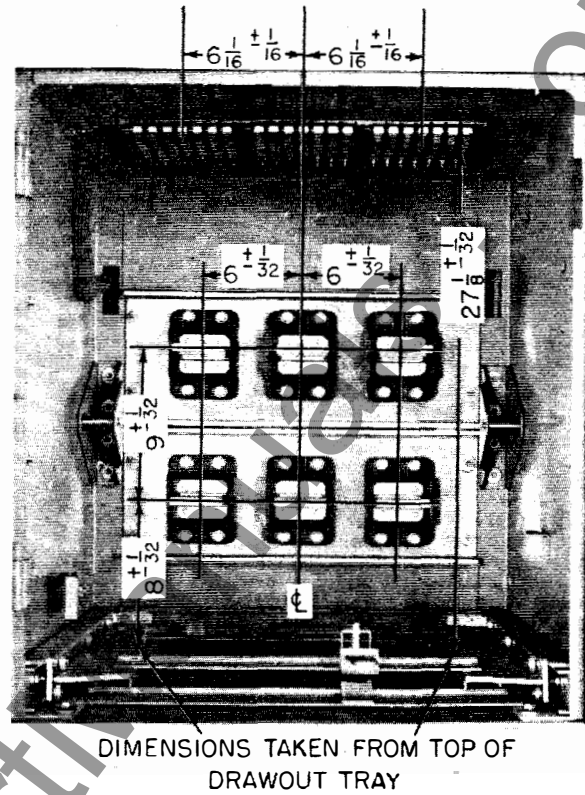

Fig. 24 Internal View of AK-15 and 25 Breaker Compartment With Stationary Primary and Secondary Disconnect Devices

Fig. 25 Internal View of AK-50 Breaker Compartment With Stationary Primary and Secondary Disconnect Devices

Fig. 26 (8028206)

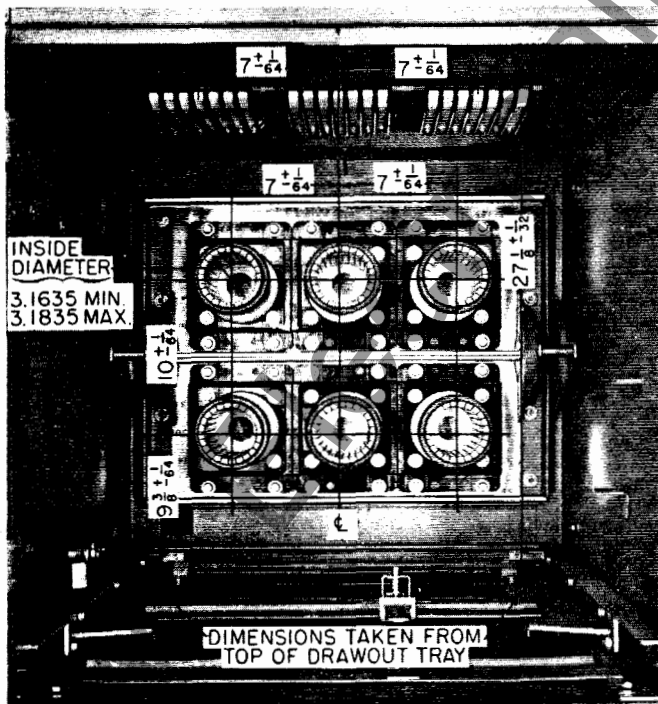

Fig. 27 (8023814)

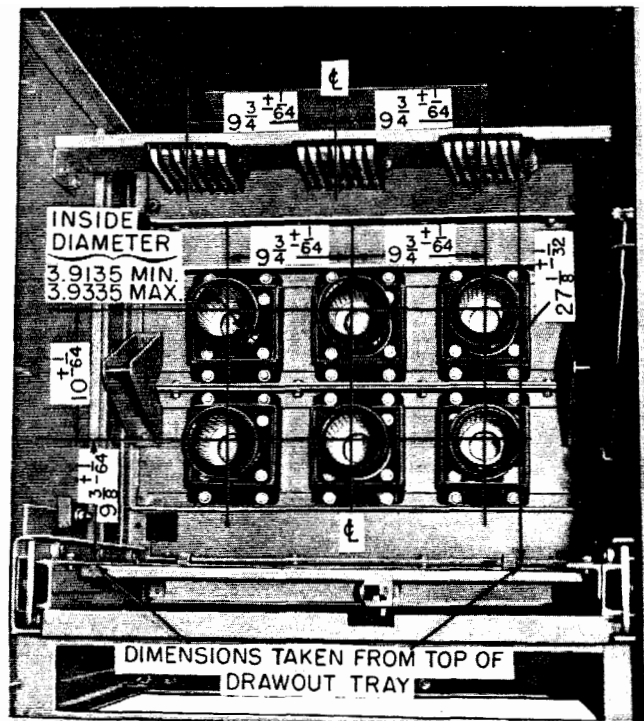

Fig. 26 Internal View of AK-75 Breaker Compartment With Stationary Primary and Secondary Disconnect Devices

Fig. 27 Internal View of AK-100 Breaker Compartment With Stationary Primary and Secondary Disconnect Devices

The procedure for inserting and withdrawing a drawout breaker from its compartment is as follows:

Inserting Breakers AK-15 and 25

1. Make sure that the breaker contacts are open.
2. Raise the breaker until the guides on the sides of the breaker are level with their mating supporting track in the compartment, Fig. 28, and slide the breaker part way into its compartment. (NOTE-The breaker will strike a position stop at the bottom of the compartment after the breaker has traveled only a short distance into the compartment. Lifting the position stop handle, located at the bottom right of the compartment, releases the position stop and allows the breaker to travel further into the compartment).
3. Raise the rackout handle forward and up as far as its travel will permit and push the breaker into the compartment, Fig. 29, until the rackout pins on the handle assembly bear against the housing rackout cams on the side of the compartment.
4. Push sharply downward on the rackout handle, Fig. 30, forcing the pins on the handle up into the slot in the stationary cam plate. This action forces the breaker through a final short portion of its movement into the compartment and allows the operator to provide the force necessary to make the primary disconnects engage the stationary studs. In performing this operation, make sure that the handle is rotated downwards as far as its free travel will permit and then pull the racking handle down to be sure that the trip interlock is released, Fig. 31-(NOTE-When the racking handle is in any

position other than completely down, the breaker cannot be operated and is held trip-free by the trip interlock. This applies to the "Connected" and "Test" positions.)

Withdrawing Breakers AK-15 and 25

1. Trip the breaker by pushing the manual trip button in the escutcheon and open the compartment door. If the breaker is not open, the interlock lever of the drawout mechanism will not permit operation of the rackout handle.
2. Pull the racking handle up and forward as far as it will travel, disengaging the primary disconnects.

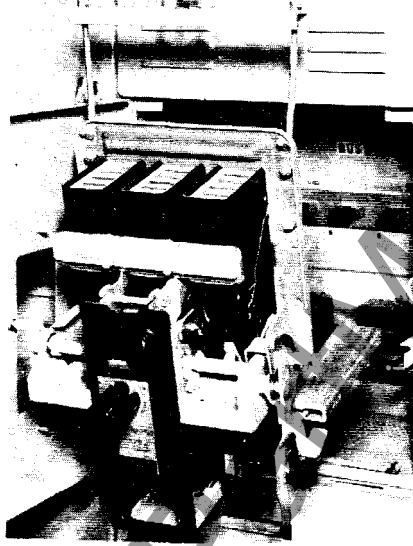

Fig. 28 AK-25 Breaker Raised To Compartment Level

3. Slide the breaker out until the position stop engages in the front slot in the bottom of the breaker carriage. The breaker has moved approximately 2-3/4 inches and is now in the "Test" position where the primary disconnects are safely disconnected from the line and load terminals of the compartment, but its secondary disconnects are still engaged. In this position, the breaker may be tested or operated, manually or electrically, without energizing the primary circuit, provided the racking handle has been moved to the completely down position, thus releasing the trip interlock.
4. Operate the breaker manually several times in the "Test" position (and also electrically if it is an electrically operated breaker) to see that it is functioning properly.
5. Complete the removal of the breaker from its compartment by lifting the position stop lever arm and sliding the breaker forward until the position stop engages the rear slot in the bottom of the breaker carriage. The breaker has now moved approximately a total of 7-1/2 inches. This is the safety position stop where both the primary and secondary disconnects are disengaged.
6. Attach the lifting device spreader and again lift the position lever, sliding the breaker slightly forward will make it completely free from its compartment.
7. The breaker can now be lowered to the desired position. When lowering the breaker make sure it is held far enough away from the front of the switchgear so that its contacts do not interfere with devices or handles on compartments beneath it as it is lowered.

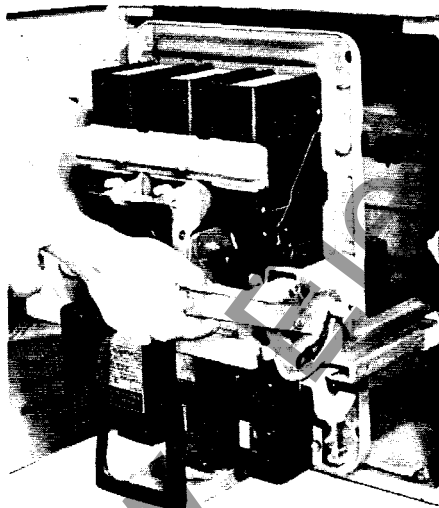

Fig. 29 AK-25 Breaker Pushed Into Compartment

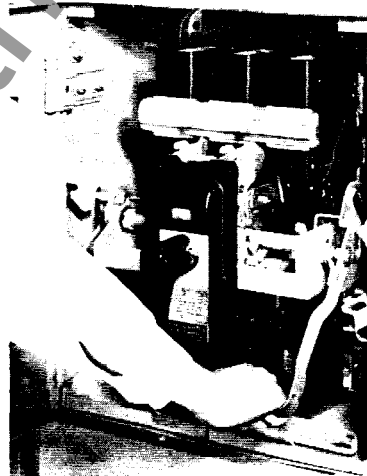

Fig. 30 AK-25 Breaker Being Racked Into "Connected" Position

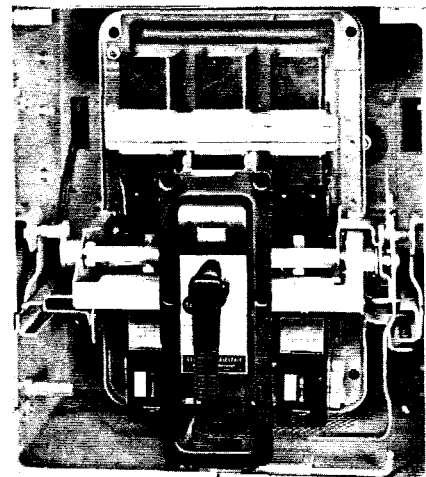

Fig. 31 AK-25 Breaker in "Connected" Position

Fig. 28 (8028110)

Fig. 29 (8028114)

Fig. 30 (8028108)

Fig. 31 (8028109)

Inserting Breakers AK-50, 75, and 100

1. Make sure that the breaker contacts are open.
2. Lift the breaker to a position approximately six inches above the height of the compartment tray, Fig. 32.
3. Pull the drawout tray out under the breaker until the limit stop is reached, Fig. 33. (NOTE - When installing an individual skeleton housing for a drawout AK-50 or 75, a bolt head must be located over the two front bottom mounting holes of the housing to provide a limit stop for the drawout tray.)
4. Lower the breaker to a distance of about 1/2 inch above the dowel pins on the tray and push the breaker back into its compartment so that the rear bottom angle of the breaker is against

the guides on the tray directly back of the dowel pins.

5. Slowly lower the breaker onto the tray and at the same time guide it so that the holes in the rear angle of the breaker fit over the two dowel pins on the tray. If the breaker is correctly positioned on the dowels, its rear and side bottom frame angles will all sit firmly on the tray, Fig. 34.
6. Insert two 3/8 inch hexagonal head bolts through the holes in the front of the side angles on the breaker and thread them part way into the tapped holes in the tray. Do not tighten bolts firmly. This permits self-alignment of the primary racking disconnects during the subsequent racking operation.
7. Push the breaker into the compartment until the test position stop engages to prevent further travel, Fig. 35.

8. Release the test position stop by depressing its lever and push the breaker back into the compartment until the racking pins on the housing butt against the outer surface of the racking cam, Fig. 36. In this position, the racking pin has lifted the locking arm on the cam which allows the racking handle to be lifted enough to allow the pawl to engage the first notch on the cam, Fig. 37.
9. When the pawl engages the first notch on the cam, push the handle down again to its normal position. This causes the cam to rotate about the racking pin. Repeat this operation five times to rack the breaker into its final "Connected" position. (NOTE - It is imperative that each stroke is performed with a positive motion and carried to its limiting position.) Interlocks hold the breaker trip-free until it is racked into the fully "Connected" position.

Fig. 32 (8023378)
Fig. 33 (8023381)



Fig. 32 AK-50 Breaker Raised To Compartment Level



Fig. 33 Drawout Tray In Position To Receive AK-50 Breaker

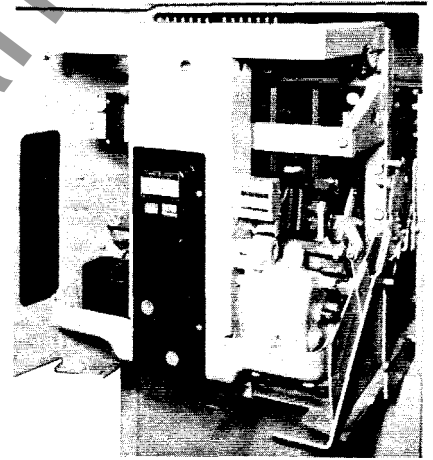

Fig. 34 AK-50 Breaker In Place On Drawout Tray

Fig. 34 (8023373)
Fig. 35 (8023379)

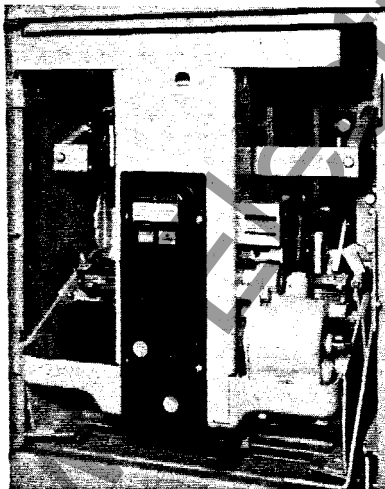

Fig. 35 AK-50 Breaker In "Test" Position

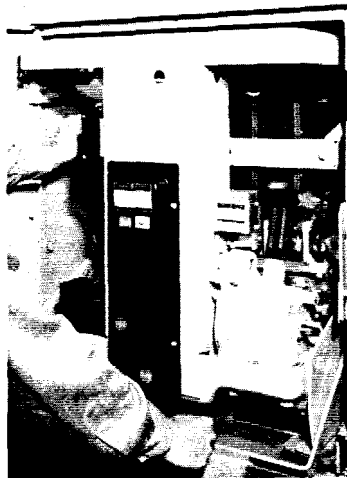

Fig. 36 AK-50 Breaker Pushed Into Compartment

Fig. 36 (8023375)
Fig. 37 (8023374)



Fig. 37 Racking Handle At Top of First Stroke

The fifth stroke of the handle is only a partial stroke and does not result in any further movement of the breaker, Fig. 38. It does serve three useful purposes: it positions the cam so that it cannot rotate and allow the breaker to back out under short circuit stresses, the partial stroke signals that the racking operation is complete, and it releases the trip interlock which was engaged by the racking pin during the previous four pumps of the racking arm. (NOTE-Once a racking operation has been started, it should be completed, as the breaker cannot be reversed until the racking operation is completed.)

10. After completing the fifth racking stroke, lift the handle as high as it will go and allow it to drop to its normal position. This operation will reverse the pawl so that it is set for a racking out operation. (NOTE-Any strokes beyond this point will cause the breaker to be trip-free.)

Tighten the 3/8 inch hexagonal head bolts inserted in the front holes of the drawout tray. The breaker is now in the "Connected" position, Fig. 39.



Fig. 38 Racking Handle At End of Fifth Stroke

the breaker can be electrically or manually operated for test without energizing the primary circuit..

5. Operate the breaker manually several times in the "Test" position (and also electrically if it is an electrically operated breaker) to see that it is functioning properly.
6. Depress the stop lever and pull the breaker the remainder of the way from its compartment until the limit stop is reached. The breaker has now moved approximately a total of 17 1/2 inches.
7. Remove the two 3/8 hexagonal head bolts which hold the breaker on the tray.
8. Attach the spreader bar to the top frame of the breaker and connect it in turn to a lifting device.
9. Lift the breaker approximately 1/2 inch off the dowel pins on the tray and then pull the breaker forward until its primary contacts clear the compartment.
10. Push the tray all the way back into the compartment. The breaker is now completely free from its compartment.
11. The breaker can now be lowered to the desired position. When lowering the breaker make sure it is held far enough away from the front of the switchgear so that its contacts do not interfere with devices or handles on compartments beneath it as it is lowered.

Fig. 38 (8023377)

Fig. 39 (8023376)

Withdrawing Breakers AK-50, 75, and 100

1. Trip the breaker to release the positive racking interlock and open the compartment door.
2. Lift the racking handle as far as it will go. This operation will re-engage the trip interlock to hold the breaker trip-free for the remainder of the racking operation. Note that here the cam is rotated by lifting the handle, whereas in racking the breaker in, the operation is performed as a result of pushing the handle down.
3. Reset the handle to its lowered position and lift it again. This operation must be performed 5 times to completely disengage the cams from their racking pins. After the fifth lifting stroke let the handle drop to its normal position. This will reverse the racking pawl and set the mechanism for racking the breaker in again.



Fig. 39 AK-50 Breaker In "Connected" Position

4. Grasp the frame of the breaker, and pull it out of its compartment until the position stop prevents further travel. The breaker has moved approximately 2 3/4 inches and is now in its "Test" position, where its primary

disconnecting contacts are separated, but its secondary disconnecting contacts are still engaged. In this position

TEST CABINET

The test cabinet, Fig. 21, should be located where maintenance and testing of the breakers can be conveniently done. If desirable this cabinet may be permanently mounted in the service area. Cables must be installed to supply a suitable source of control power for testing.

ADDITION OF UNITS TO EXISTING EQUIPMENT

When adding a new unit to an existing equipment, the end cover must be removed from the existing equipment, and bolted onto the end of the new unit. Otherwise, the procedure is the same as described for SHIPPING SPLITS. Gaskets for roof caps and at the vertical edge of front and rear doors must be replaced on outdoor equipment when new units are added.

TESTING AND INSPECTION

After the equipment has been installed and all connections made it should be tested and inspected before putting it in service. Although the equipment and devices have been completely tested at the factory, a final field test should be made to be sure that the equipment has been properly installed and that all connections are correct and have not become loose. The primary equipment should be completely de-energized while the tests are in progress.

Directions for testing devices such as relays, instruments, and meters are given in the instruction book furnished for each device. The settings of the protective relays must be coordinated with the other relays on the system and therefore these relays must be set by the purchaser.

General instructions on setting the relays are given in the relay instruction books. Special instructions are furnished for complicated automatic equipments, describing the sequence of operation of the devices required to perform the desired function.

The extent of the tests on the equipment as a whole will depend on the type and function of the equipment.

When a battery is used to supply the control power, the cables from the battery to the switchgear should be large enough to avoid excessive voltage drop. The voltage at the terminals of the breaker closing device, when the breaker is being closed should not be less than 90 volts

for 125 volt coils and 180 volts for 250 volt coils.

All AK breaker compartments contain a "Test" position in which the breaker primary contacts are parted and in which the secondary contacts are still engaged. The "Test" position permits complete testing of the electrical control circuit without energizing the primary circuit. When the breaker is first put into service, its control circuit should be thoroughly tested while in this position to make sure that all closing and tripping circuits are complete and function properly. In general, the parts of the electrically operated breaker are inaccessible when in the compartment in the "Test" position. Therefore, this "Test" position is not suitable for inspection

and maintenance of the breaker, and should not be used as such.

On manual breakers, this "Test" position can be used to insure proper operation of the breaker before using it to energize the circuit. Again, the amount of servicing which can be done on the breaker is limited due to the fact that it is confined in its compartment. However, some parts of the breaker are far more accessible than in the case of the electrically operated breaker. This is due to the elimination of the closing mechanism and trip

devices which are always located in front of the main contact assemblies.

When it is necessary to test the breaker more thoroughly than above, or to do maintenance work on it, provisions should be made to perform these operations with the breaker removed from its compartment. This work should preferably be done in a service area where sufficient room and light are available to facilitate the work. This service area should include means for testing the electrical parts of the breaker as well as means for making mechanical checks and adjustments. To aid in the electrical check, a

test cabinet is available to close and trip electrically operated breakers.

High potential tests to check the integrity of the insulation are not necessary if the installation instructions in this book are carefully followed. If the purchaser wishes to make high potential tests the voltage should not exceed 75% of the AIEE factory test voltage. The AIEE factory test voltage is "2 times switchgear rating plus 1000" volts.

Potential and control power transformers must be disconnected during high voltage testing.

MAINTENANCE

A regular maintenance schedule should be established to obtain the best service and reliability from the switchgear. Plant, operating and local conditions will dictate the frequency of inspection required. For specific information regarding the maintenance of devices, such as circuit breakers, relays, meters, etc., refer to the separate instruction book furnished for each device. The test cabinet, if furnished, provides a convenient means for maintaining the circuit breakers. Under normal conditions the protective relays do not operate; therefore, it is important to check the operation of these devices regularly.

A permanent record of all maintenance work should be kept, the degree of detail depending on the operating conditions. In any event it will be a valuable reference for subsequent maintenance work and for station operation. It is recommended that the record include reports of tests made, the condition of equipment, and repairs and adjustments that were made.

Maintenance employees must follow all recognized safety practices, such as those contained in the National Electrical Safety Code and in company or other local safety regulations during maintenance. Solid insulation surrounding an energized conductor in power apparatus must never be relied upon to provide protection to personnel.

ANNUAL MAINTENANCE PROCEDURE

The switchgear structure and connections should be given the following overall maintenance at least annually. The frequency of the maintenance period will depend upon the severity of the service and the atmospheric conditions around the units. Equipment subject to highly repetitive operation may require more frequent maintenance.

None of the following operations should be undertaken until it is certain that the equipment is completely de-energized.

De-energize the equipment completely by removing all sources of power, both primary and secondary.

1. Thoroughly clean by removing all dust and other accumulations from the equipment. Wipe or vacuum clean the buses and supports. Avoid the use of compressed air for blowing out the equipment. Inspect the buses and connections carefully for evidence of overheating or weakening of the insulating supports. Check indicating devices, mechanical and key interlocks, to see that they are functioning properly.

2. After cleaning with breakers removed, megger, and record the resistance to ground and between phases of the insulation of buses and connections. Since definite limits cannot be given for satisfactory insulation resistance values, a record must be kept of the readings. Weakening of the insulation from one maintenance period to the next can be recognized from the recorded readings. The readings should be taken under similar conditions each time if possible, and the record should include the temperature and humidity.

High potential tests are not required, but if it seems advisable, based on the insulation resistance tests or after repairs, the test voltage should not exceed 75% of the AIEE factory test voltage which is "2 times switchgear rating plus 1000" volts. The potential and control power transformers must be disconnected during the high voltage testing.

3. Check primary disconnecting device contacts for signs of abnormal wear or overheating. Clean contacts with silver polish. Discoloration of the silvered surfaces is not ordinarily harmful unless atmospheric conditions cause deposits such as sulphides on the contacts. The deposits can be removed with a good grade of silver polish.

Before replacing the breaker removable element, check the alignment and wipe off the primary disconnecting device contacts and apply a thin coat of contact lubricant D50H47 to breaker studs or fingers.

4. Check to see that all anchor bolts and bolts in the structure are tight. Inspect all cable connections for signs of overheating and tighten all loose connections. Check to ascertain that all secondary connections are secure and all control wiring is intact.

5. Operate each breaker while in the "Test" position to be sure it functions properly. This is particularly important for breakers that normally remain in either the opened or closed positions for long periods of time. A maintenance closing device is provided for manually closing electrically operated circuit breakers.

6. Stress corrosion cracking of stainless steel garter springs may result where highly stressed parts are subjected to various corrosive atmospheres. If the equipment is located near pickling

tanks or other corrosive installations where the atmosphere contains chlorine or chlorides, the springs must be protected with a grease such as D50H47, and replaced periodically as part of the regular maintenance program.

When the switchgear equipment is subjected to unusual service conditions, such as contaminating fumes, excessive moisture, etc., maintenance should be scheduled at more frequent intervals. In this case, the procedure listed above may not be sufficient for proper maintenance, and additional precautions may be necessary to protect the equipment from the unusual conditions encountered.

FUNGICIDE TREATMENT

Equipment that will require special treatment against fungus will be sprayed with a fungicide prior to shipment. This treatment is effective for a limited time only (approximately 6 months). The equipment should be checked periodically for signs of fungus growth and properly treated as required.

OUTDOOR ACRYLIC PAINT FINISH

The outside of standard outdoor switchgear has an acrylic paint finish, blue gray ASA#24, providing improved resistance to all atmospheric conditions, longer life and less maintenance than with ordinary paint finishes.

If it is desired to refinish acrylic painted switchgear, it is necessary to use one of the following procedures in order to secure the best adhesion of the paint to the original finish.

A. Refinishing with Acrylic Paint. It is recommended that refinishing be done with DuPont acrylic paint of the desired color. Obtain materials and instructions for application from the DuPont Company.

B. Refinishing with Alkyd or Oil Base Paints. Two methods are recommended:

- (1) Spray one sealer coat of DuPont 233E75300 or equivalent which has been reduced to spraying viscosity with DuPont 37692 or 37666 thinner. Air dry for one hour. Apply alkyd or oil base paint.

- (2) Spray one sealer coat of Arco 214-806 primer which has been reduced to spraying viscosity with Xylol. Air dry for one hour. Apply alkyd or oil base paint.

www.ElectricalPartManuals.com