

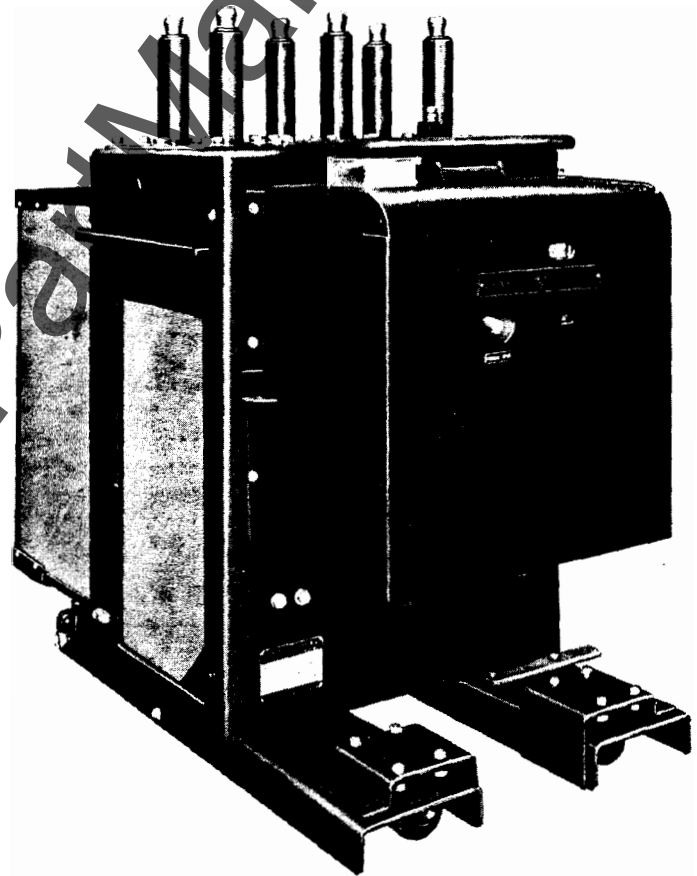

# POWER CIRCUIT BREAKERS

## Magne-blast Breakers Types

AM-7.2-250-1 and -2  
AM-7.2-250A-1 and -2  
AM-7.2-500-1 and -2  
AM-7.2-500A-1 and -2  
AM-13.8-150-1 and -2  
AM-13.8-150A-1 and -2  
AM-13.8-250-1 and -2  
AM-13.8-250A-1 and -2  
AM-13.8-500-1 and -2  
AM-13.8-500A-1 and -2  
AM-13.8-500B-1 and -2  
AM-13.8-500AB-1 and -2  
With MS-13 Mechanism



MEDIUM VOLTAGE SWITCHGEAR DEPARTMENT

GENERAL  ELECTRIC

PHILADELPHIA, PA.

[www.ElectricalPartManuals.com](http://www.ElectricalPartManuals.com)

# CONTENTS

|  | PAGE |
|--|------|
| INTRODUCTION .....   | 3    |
| RECEIVING, HANDLING AND STORAGE .....  | 3    |
| RECEIVING AND HANDLING .....   | 3    |
| STORAGE .....  | 4    |
| DESCRIPTION .....  | 5    |
| INSTALLATION .....   | 6    |
| ADJUSTMENTS .....  | 6    |
| Primary Contact Wipe .....   | 6    |
| Arcing Contact Wipe .....  | 6    |
| Primary Contact Gap .....  | 7    |
| Arcing Contact Clearance .....   | 7    |
| Trip Latch Wipe .....  | 8    |
| Prop Clearance .....   | 9    |
| Closing Plunger Clearance .....  | 9    |
| Latch Checking Switch Wipe .....   | 9    |
| Cut-off Switch Adjustments .....   | 9    |
| Impact Trip, Current Trip, Capacitor Trip, and Undervoltage Trip Devices ..... | 10   |
| Plunger Interlock .....  | 10   |
| Auxiliary Switch Linkage .....   | 11   |
| FINAL INSPECTION AND TEST .....  | 11   |
| Hi-potential Test .....  | 11   |
| Auxiliary Devices .....  | 11   |
| Control Power Check .....  | 12   |
| OPERATION .....  | 12   |
| CLOSING OPERATION .....  | 12   |
| OPENING OPERATION .....  | 17   |
| TRIP FREE OPERATION .....  | 17   |
| MAINTENANCE .....  | 17   |
| PERIODIC INSPECTION .....  | 17   |
| Arc Chutes .....   | 17   |
| Breaker Contacts .....   | 18   |
| Mechanism .....  | 18   |
| Bushings and Insulation .....  | 18   |
| LUBRICATION .....  | 18   |
| Method of Cleaning Bearings .....  | 19   |
| TROUBLE SHOOTING .....   | 19   |
| Failure to Trip .....  | 19   |
| Failure to Close or Latch Closed .....   | 19   |
| Overheating .....  | 20   |
| REPAIR AND REPLACEMENT .....   | 20   |
| Arc Chutes and Lower Arc Runners .....   | 20   |
| Contacts .....   | 21   |
| Bushings .....   | 21   |
| Closing Coil .....   | 22   |
| Trip Coil .....  | 23   |
| Latch Checking Switch .....  | 23   |
| Cut-off Switch .....   | 23   |
| RENEWAL PARTS .....  | 24   |
| RECOMMENDATIONS .....  | 24   |
| ORDERING INSTRUCTIONS .....  | 24   |

www.ElectricalPartManuals.com

[www.ElectricalPartManuals.com](http://www.ElectricalPartManuals.com)

# MAGNE-BLAST CIRCUIT BREAKERS

## TYPES AM-7.2 AND AM-13.8 WITH TYPE MS-13 MECHANISM

### INTRODUCTION

The Magne-blast Circuit Breaker is designed primarily for installation in Vertical-lift Metal-clad Switchgear, its function being to provide reliable control and protection of power station equipment. Among the many advantages of Metal-clad Switchgear are compactness, simplified installation and added protection to equipment and personnel. In keeping with these features, the Magne-blast Circuit Breaker is designed for interchangeability and maneuverability, together with maximum reliability and minimum maintenance requirements.

The Magne-blast Circuit Breaker operates on the principle that an arc can be satisfactorily interrupted in air by rapidly and sufficiently elongating and cooling it. This is accomplished by means of a strong magnetic field that lengthens the arc and forces it into intimate contact with cool dielectric material. A sturdy, reliable operating mechanism assures low maintenance and long life, and the use of flame-retardant materials reduces fire hazard to a minimum.

The AM-7.2 and AM-13.8 Magne-blast Breakers are available in a number of ratings and styles as

shown on page four of this instruction book. For the complete rating information of any particular breaker, refer to the breaker nameplate.

The short circuit conditions to be imposed on the breaker must not exceed its rating, nor should it be called upon to operate at voltages or currents greater than those given on the nameplate. Since this instruction book is written to cover several ratings of breakers that are of the same general design, all instructions will be general in nature and all illustrations will be typical, unless otherwise specified.

**PROPER INSTALLATION AND MAINTENANCE ARE NECESSARY TO INSURE CONTINUED SATISFACTORY OPERATION OF THE BREAKER.** The following instructions will provide complete information for placing the Magne-blast breaker in service and for maintaining satisfactory operation. A brief description of the design and operating principles of the breaker is also given, as a clear conception of the function of the various parts of the breaker is helpful in understanding the installation operation and maintenance procedures.

### RECEIVING, HANDLING AND STORAGE

#### RECEIVING AND HANDLING

Each breaker is carefully inspected and packed by workmen experienced in the proper handling and packing of electrical equipment. Immediately upon receipt of the circuit breaker, an examination should be made for any damage sustained in transit. If injury or rough handling is evident, a damage claim should be filed immediately with the transportation company and the nearest General Electric Sales Office should be notified.

It is expected that due care will be exercised during the unpacking and installation of the breaker so that no damage will occur from careless or rough handling, or from exposure to moisture or dirt. A nail puller should be used to open the crates, and care should be exercised to prevent tools from striking either the crate or any part of the breaker.

Loose parts associated with the breaker are always included in the same crate. Check all parts against the packing list to be sure that no parts have been overlooked. After removing the breaker, from the crate, remove the shipping brace (2) Fig. 1, and the shipping protectors (1).

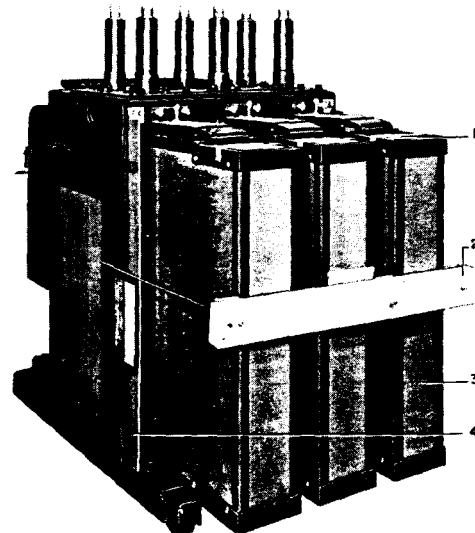

1. Shipping Protectors
2. Shipping Brace
3. Box Barrier
4. Side Barrier

Fig. 1 Breaker After Removal From Packing Crate

*These instructions do not purport to cover all details or variations in equipment nor to provide for every possible contingency to be met in connection with installation, operation or maintenance. Should further information be desired or should particular problems arise which are not covered sufficiently for the purchaser's purposes, the matter should be referred to the General Electric Company.*

[www.ElectricalPartManuals.com](http://www.ElectricalPartManuals.com)

## STORAGE

It is recommended that the breaker be put into service immediately in its permanent location. If this is not possible, the following precautions must be taken to insure the proper storage of the breaker:

1. The breaker should be carefully protected against condensation, preferably by storing it in a warm dry room, since water absorption has an adverse effect on the insulation parts. Circuit breakers for outdoor Metal-clad Switchgear should be stored in the equipment only when power is available and the heaters are in operation to prevent condensation.

2. The breaker should be stored in a clean location, free from corrosive gases or fumes; particular care should be taken to protect the equipment from moisture and cement dust, as this combination has a very corrosive effect on many parts.
3. Machined parts of the operating mechanism, etc., should be coated with a heavy oil or grease to prevent rusting.

If the breaker is stored for any length of time, it should be inspected periodically to see that rusting has not started and to insure good mechanical condition. Should the breaker be stored under unfavorable atmospheric conditions, steps should be taken to dry out the breaker before it is placed in service.

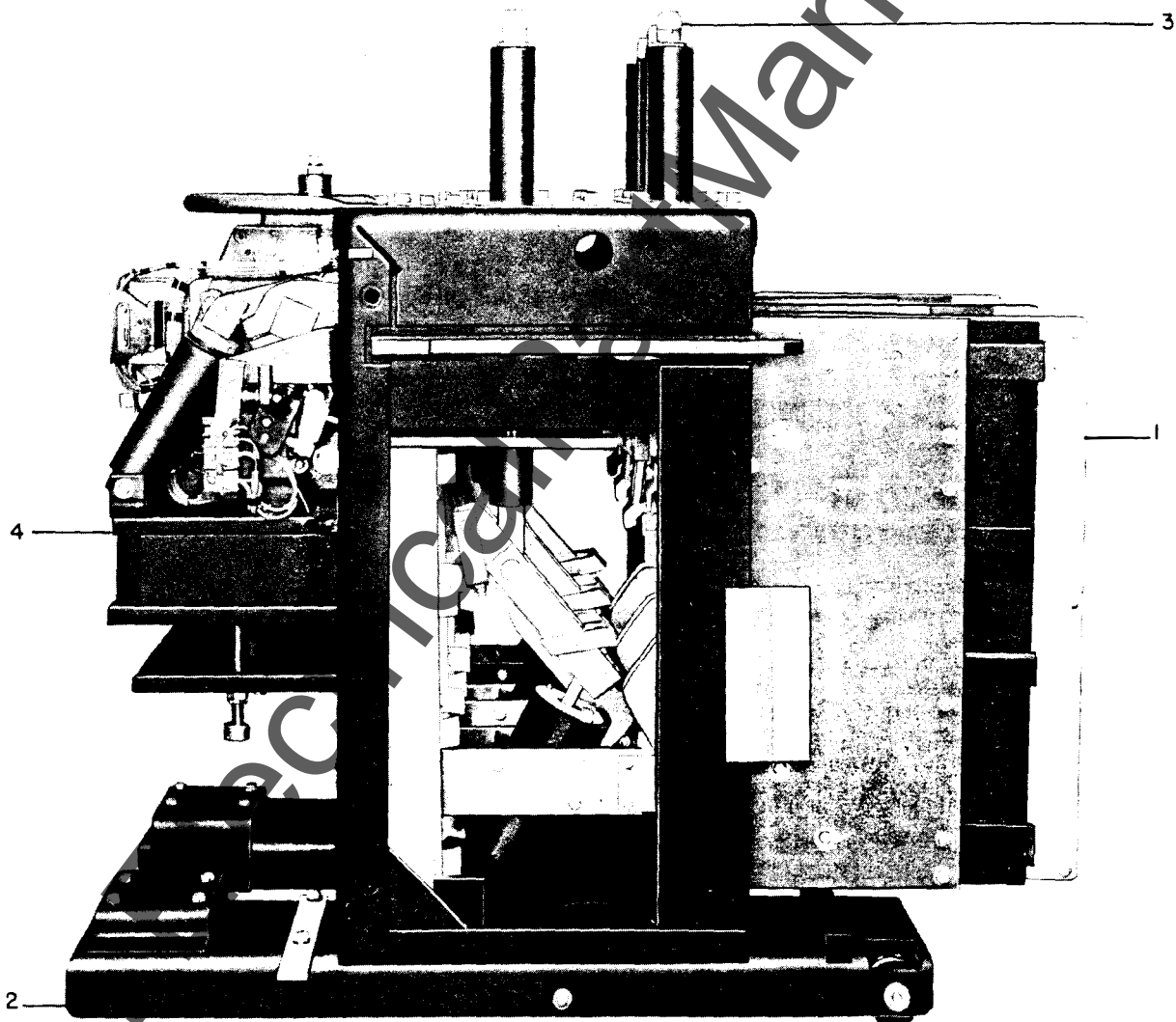

1. Breaker Element  
2. Frame

3. Primary Disconnect Studs  
4. Solenoid Operating Mechanism

Fig. 2 Type AM-13.8 Breaker, with Mechanism Cover and Box Barrier Removed

[www.ElectricalPartManuals.com](http://www.ElectricalPartManuals.com)



1. Plunger Interlock
2. Secondary Coupler
3. Auxiliary Switch
4. Opening Spring Unit
5. Manual Trip
6. Control Device
7. Closing Solenoid
8. Closing Armature
9. Control Device Plunger

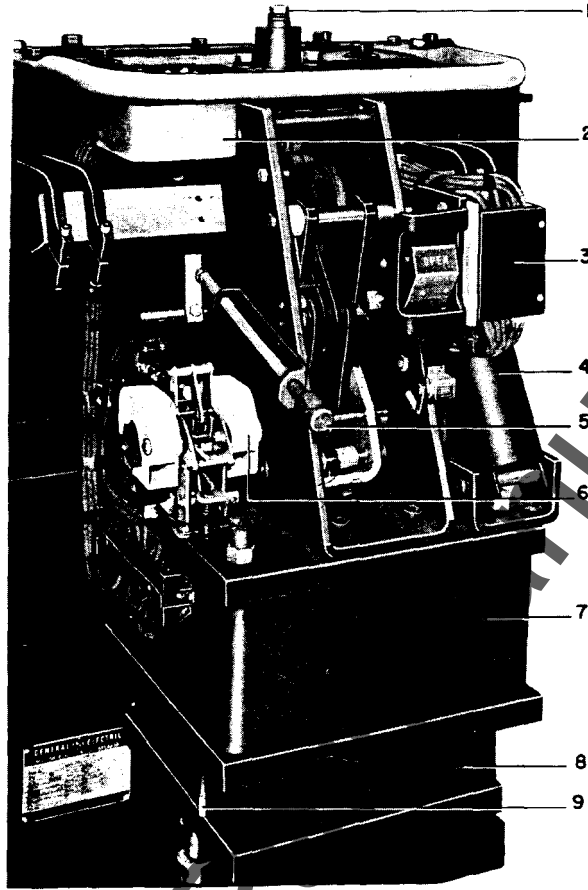

Fig. 3 Type MS-13A Operating Mechanism

## DESCRIPTION

The Magne-blast breaker, shown in Fig. 2, is composed of two major parts, namely the breaker element and the operating mechanism. The breaker element comprises three similar pole units, each pole unit consisting of main and arcing contacts, an interrupter, and an enclosing box barrier that segregates the interrupting units from each other to provide insulation between phases as well as from each phase to ground. The primary connections to the associated Metal-clad equipment are made through the primary disconnect studs.

The MS-13A (also MS-13B) operating mechanism shown in Fig. 3 is of the solenoid type designed to give high speed closing and opening. The closing operation is controlled by the control device (6). This device also permits trip free operation (tripping the breaker at any time during the closing operation), and prevents solenoid pumping (reclosing) after a trip free operation. For AC closing operation, two copper-oxide rectifiers, mounted elsewhere in the Metal-clad unit, are used to supply the direct current on which the closing coil operates. The breaker can be opened electrically, by remote control, or manually, by means of the manual trip device (5). All secondary connections from the breaker to the

Metal-clad unit are made through the coupler (2).

A plunger interlock (1), is used where it is desirable to prevent having two adjacent breakers closed at the same time, or it can be used to operate an auxiliary switch mounted in the metal-clad unit. A metal-clad interlock is provided to prevent the breaker from being raised in the metal-clad unit while in the closed position, and to block the breaker open until it is completely raised. It is also used to prevent the breaker from being lowered while in the closed position.

The MS-13D and MS-13E mechanisms are slightly different in construction from the MS-13A and MS-13B, but their operation is principally the same. A relay arrangement is used in place of the control device, and two secondary couplers are used instead of one. Also, in place of the metal-clad interlock, the MS-13D and MS-13E mechanisms have a trip interlock, which trips the breaker when any attempt is made to install or remove the breaker from the Metal-clad unit when in the closed position. For a detailed explanation of the operation of the breaker and mechanism, refer to the section OPERATION.

[www.ElectricalPartManuals.com](http://www.ElectricalPartManuals.com)

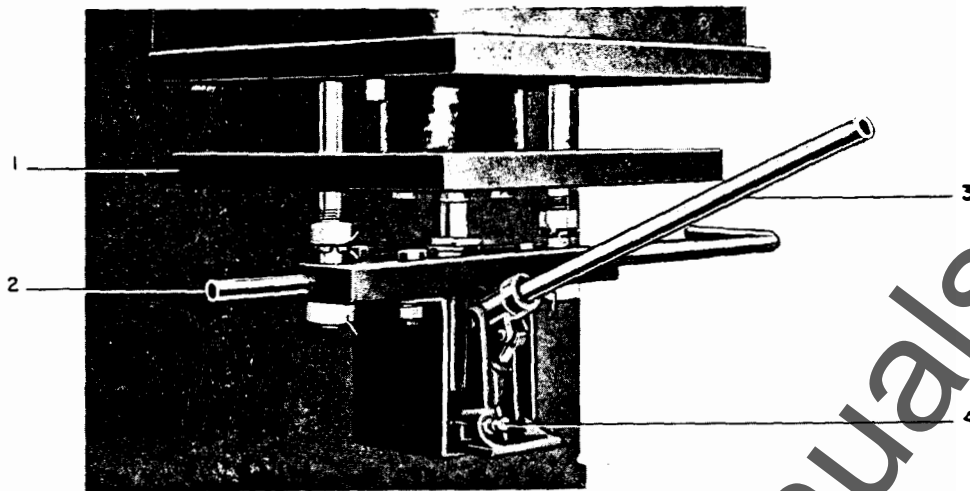

1. Closing Armature  
2. Maintenance Operating Device  
3. Handle  
4. Release Valve

Fig. 4 Method of Mounting Maintenance Operating Device

## INSTALLATION

The following instructions explain the necessary steps to be taken before the breaker is placed in the metal-clad unit. This includes a complete check of all of the breaker adjustments, in addition to a thorough inspection. For final installation instructions refer to the Metal-Clad Switchgear instruction book. Reference should also be made to the connection diagram that is furnished with each unit.

NOTE: Do not work on either the breaker or the mechanism while in the closed position unless the prop and trip latch have been securely wired or blocked to prevent accidental tripping.

### ADJUSTMENTS

Although the breaker has been completely adjusted and tested at the factory, it is possible that unusually rough handling during transportation may have caused some loosening or disturbance of parts of the apparatus. It is therefore advisable to review all adjustments before placing the breaker in service making readjustments wherever necessary.

A maintenance operating device is provided for operation of the breaker during these adjustment checks. Mount the device as shown in Fig. 4, and turn the release valve (4) firmly to the right. To close the breaker, operate the handle (3) with a pumping motion. By turning the release valve (4) to the left, the closing armature will return to its normal position. Electrical operation must not be attempted until the breaker has been operated manually through its complete stroke several times and final installation inspection has been completed.

All adjustments should be checked not only during the initial installation of the breaker but also

during periodic inspections and whenever it becomes necessary to repair or replace parts that have become worn or defective while in service. The following adjustments are listed in the order in which they are to be checked. First, however, remove the breaker from the metal-clad unit and, referring to Fig. 1, remove the box barriers (3), the side barriers (4), and the mechanism cover.

### PRIMARY CONTACT WIPE

When the breaker is closed, as shown in Fig. 5 the primary contacts (1) should rise  $5/16'' + 0 - 1/16''$ . To obtain this adjustment open the breaker and, referring to Fig. 6, loosen the check nut (5) and turn the thumb nut (4). Screwing up on the thumb nut will decrease the primary contact wipe, down will increase it. Tighten the check nut, close the breaker and recheck the wipe. With the primary contact wipe correctly adjusted, the clearance between the contact blade and the buffer block (3), Fig. 5 should be  $1/16''$  or greater, when the breaker is fully closed.

### ARCING CONTACT WIPE

Refer to Fig. 5. Close the breaker until the arcing contacts just touch. This can be determined with the use of a circuit continuity tester such as a light indication or bell set. In this position the gap between the primary contact fingers (1) and the primary contact blocks (2) should be  $5/16''$  or greater. This setting has been made in the factory and no adjustment is provided. A wipe of less than  $5/16''$  is usually an indication that the arcing contacts need to be replaced. When making this check, also see that the movable arcing contact (5) passes through the slot in the upper arc runner (7) without touching.

[www.ElectricalPartManuals.com](http://www.ElectricalPartManuals.com)

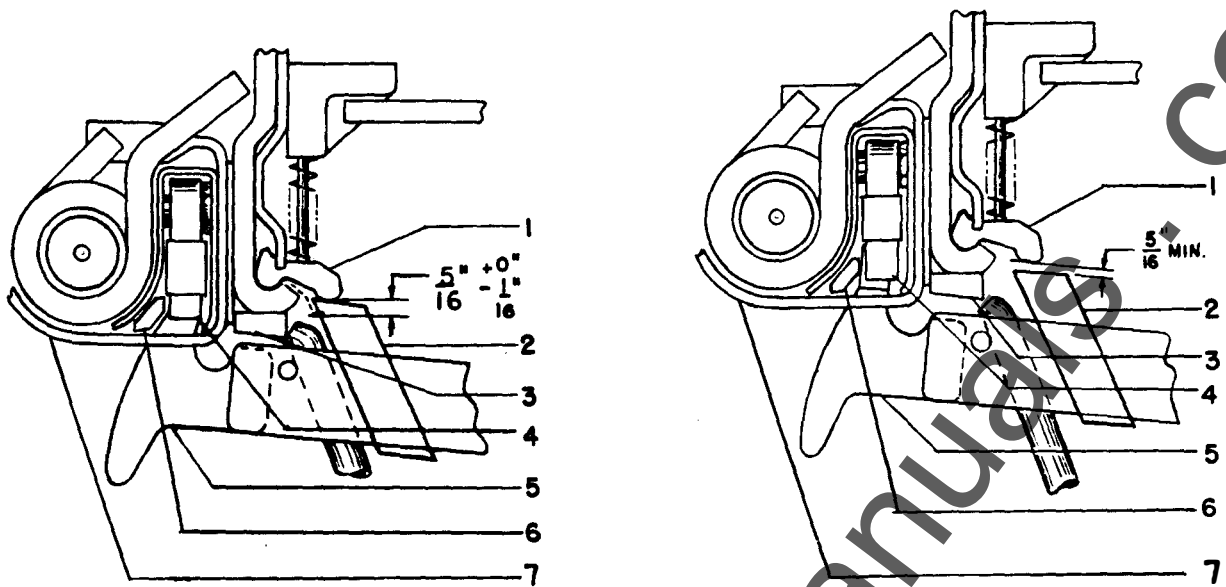

Primary Contact Wipe

Arcing Contact Wipe

1. Stationary Primary Contacts
2. Movable Primary Contacts
3. Buffer Block

4. Stationary Arcing Contacts
5. Movable Arcing Contacts
6. Coil Protector
7. Arc Runner

Fig. 5 Contact Adjustments

PRIMARY CONTACT GAP

Refer to Fig. 5. Press the manual trip button allowing the breaker to trip open normally. Do not force the contacts open wider by hand. The gap between the stationary primary contact (1) and the movable primary contact (2) should be  $5 \frac{7}{16} + \frac{1}{8} - \frac{5}{16}$ ". The difference between maximum and minimum gaps should not exceed  $\frac{5}{16}$ ". To obtain this adjustment, first open the breaker. Referring now to Fig. 7, loosen the clevis bolt (8) and turn the adjustable stud (9) of the opening spring housing (11). Unscrewing the cap will decrease the primary contact gap. After making the adjustment, close and trip the breaker and measure the gap once more. If correct, tighten the clevis bolt. When the breaker is in the open position make certain that the movable arcing contact (5), Fig. 9, does not touch the sides of the arc chute.

ARCING CONTACT CLEARANCE (See Fig. 16)

The clearance between the arcing contact blade (7) and the lower arc runner (8), with the breaker open, should be not less than  $\frac{1}{8}$ " as shown in Fig. 16. To obtain this clearance, loosen the arc chute assembly bolts and insert a wedge or block between the arcing contact blade and the lower arc runner, shifting the arc runner as required to obtain the  $\frac{1}{8}$ " minimum clearance. Before tightening the assembly bolts, check to make sure that the arc chute fins are equally spaced. Be sure to remove the wedge or block used to make the adjustment.

Fig. 5 (374A294) & (374A295)

Fig. 6 (8011973)

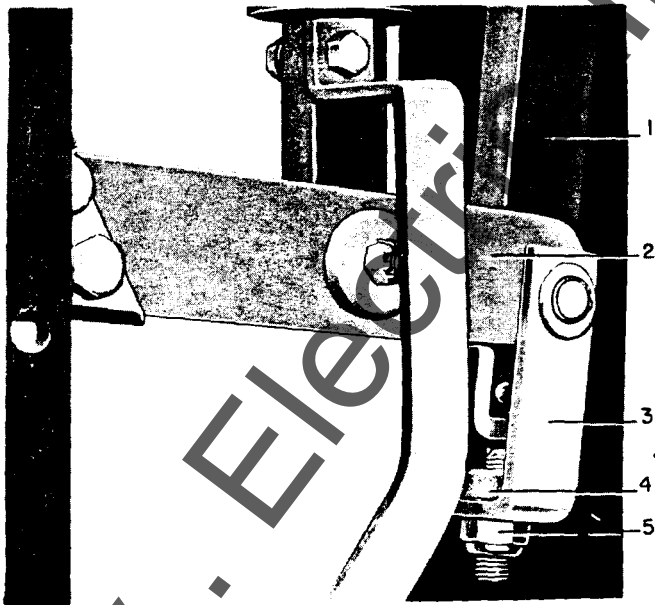

1. Operating Rod
2. Contact Arm
3. Coupling
4. Thumb Nut
5. Check Nut

Fig. 6 Adjustable Coupling for Making Primary Contact Wipe Adjustment

[www.ElectricalPartManuals.com](http://www.ElectricalPartManuals.com)

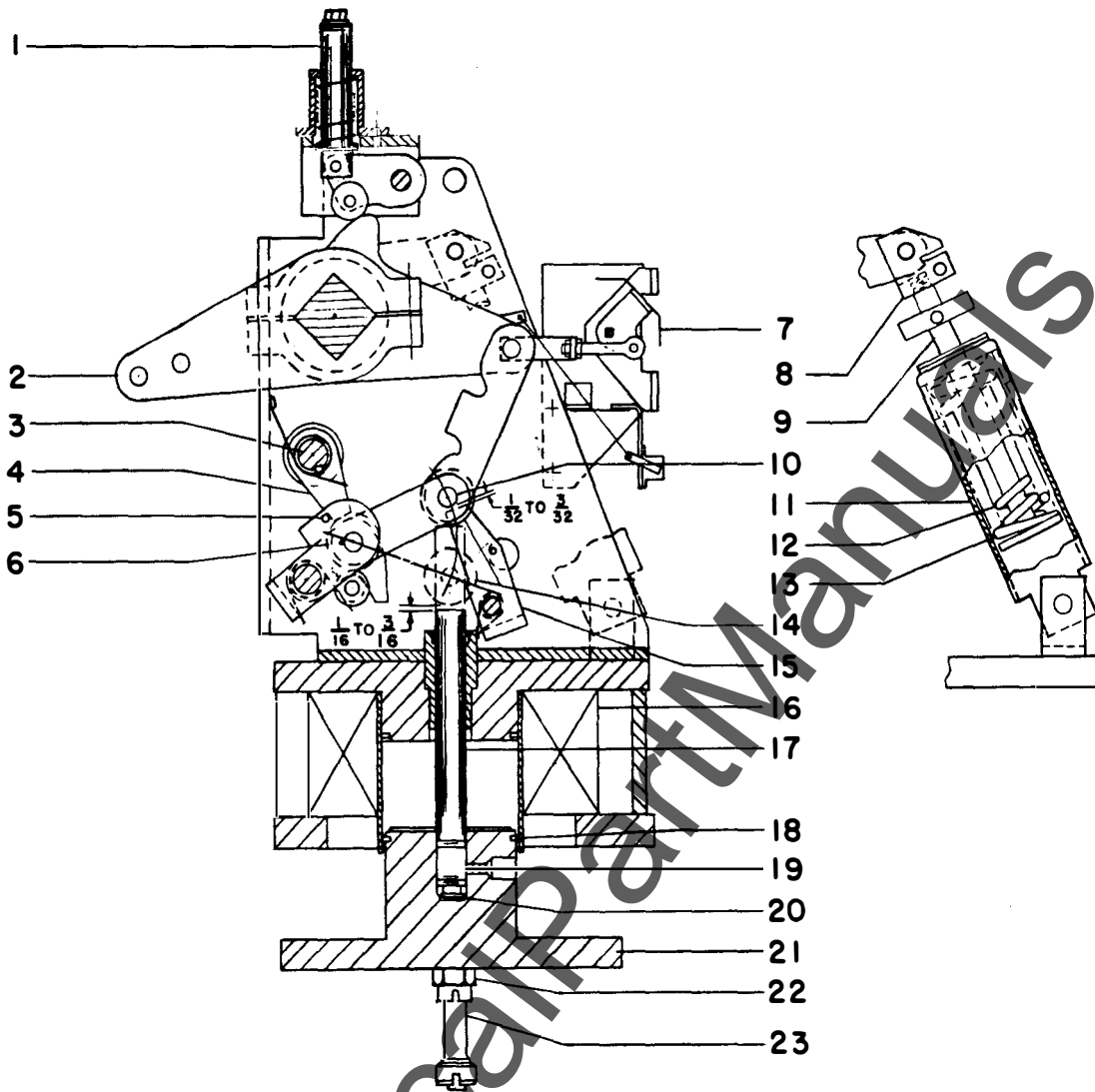

- |                       |                            |                          |
|-----------------------|----------------------------|--------------------------|
| 1. Plunger Interlock  | 9. Adjustable Stud         | 17. Closing Plunger Rod  |
| 2. Main Crank         | 10. Closing Pin            | 18. Piston Ring          |
| 3. Trip Shaft         | 11. Opening Spring Housing | 19. Set Screw            |
| 4. Trip Latch         | 12. Opening Spring, Inner  | 20. Shims                |
| 5. Trip Latch Stop    | 13. Opening Spring, Outer  | 21. Closing Armature     |
| 6. Trip Roller        | 14. Closing Roller         | 22. Stop Nuts            |
| 7. Position Indicator | 15. Prop                   | 23. Armature Guide Bolts |
| 8. Clevis             | 16. Closing Coil           |                          |

Fig. 7 Cross Section of MS-13 Mechanism

**\* TRIP LATCH WIPE**

Refer to Fig. 7. The wipe of the trip latch (4) on the trip roller (6) should be from 3/16" to 1/4". This can be measured by putting a film of grease on the latch (4), closing the breaker part way, and tripping. The mechanism has the proper trip latch wipe when the latch rests against the stop pin (5).

No adjustment is provided and a visual inspection is usually all that is required. If this setting is not correct look for insufficient travel of the trip shaft (3).

**NOTE:** When working on the mechanism in the closed position, keep fingers clear of the linkage as accidental tripping can cause severe injury.

[www.ElectricalPartManuals.com](http://www.ElectricalPartManuals.com)



**★ PROP CLEARANCE**

Fig. 8 (8010922)

Refer to Fig. 7. With the breaker closed as far as possible with the maintenance handle, the clearance between the closing pin (10) and the prop (15) should be  $1/32''$  to  $3/32''$ . Measure the prop clearance with a feeler gage to determine whether or not an adjustment should be made, and if so, exactly how much adjustment will be required. To make the adjustment, it will first be necessary to open the breaker and remove the maintenance operating device. Then remove the two stop nuts (22) being careful not to drop the armature (21). Remove the armature from the breaker. Remove the two set screws (19) and the closing plunger (17) from the armature. Add or subtract the necessary thickness of shims (20) to give the required adjustment, then replace the closing plunger, screwing it down against the shims. Using a small drill, spot the closing plunger through the set screw hole. Replace the set screws. To reinstall the armature, compress the piston ring (18). After reassembly, remount the maintenance operating device and check the adjustment.

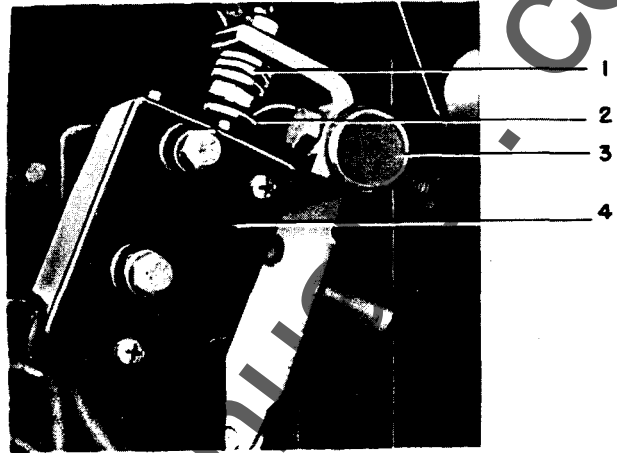

1. Washers
2. Switch Plunger
3. Trip Shaft
4. Latch Checking Switch

Fig. 8 Latch Checking Switch Wipe

**CLOSING PLUNGER CLEARANCE**

Refer to Fig. 7. With the breaker in the open position, the clearance between the closing plunger (17) and the closing roller (14) should be  $1/16'' + 1/8'' - 0$ . To obtain this clearance, the nut (22) on the two armature guide bolts (23) may be raised or lowered. Both nuts should be moved the same amount. After making an adjustment, close and open the breaker and recheck the plunger clearance. Repeat the adjustment if necessary.

**★ LATCH CHECKING SWITCH WIPE**

Fig. 9 (801679)

Referring to Fig. 8, first rotate the trip shaft (3) manually clockwise to release the switch plunger (2). Then, allowing the trip shaft to return to the reset position (counterclockwise), measure the travel of the switch plunger after the contacts make. This is the wipe, and should measure not less than  $1/32''$ . Let the trip shaft (3) return to normal, then press the plunger (2) in as far as it will go. This additional motion is the overtravel and should be at least  $1/32''$ . The point of contact can be determined with a light indication or bell set. To change the amount of wipe it is only necessary to increase or decrease the number of washers (1).

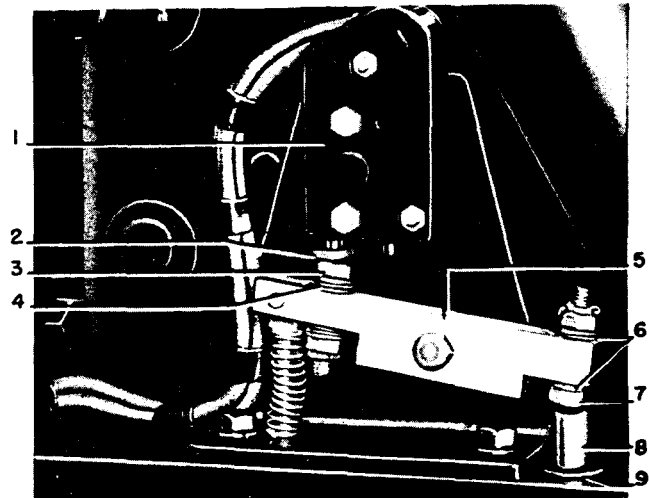

1. Cut-off Switch
2. Switch Plunger
3. Adjustment Screw
4. Washers
5. Lever Arm
6. Washers
7. Adjusting Bolt
8. Plunger Guide

**CUT OFF SWITCH ADJUSTMENTS**  
(AM-7.2-A-1, -13.8-A-1, -13.8-AB-1)

*Not on Bks.*

Refer to Fig. 9. With the breaker in the open position, the clearance between the switch plunger and the adjusting screw is obtained by pushing the switch plunger (2) in as far as it will go. In this position the clearance between the switch plunger (2) and the adjustment screw (3) should be approximately  $1/32''$ . This can be obtained by changing the number of washers (4).

Fig. 9 Cut-off Switch Adjustments

[www.ElectricalPartManuals.com](http://www.ElectricalPartManuals.com)

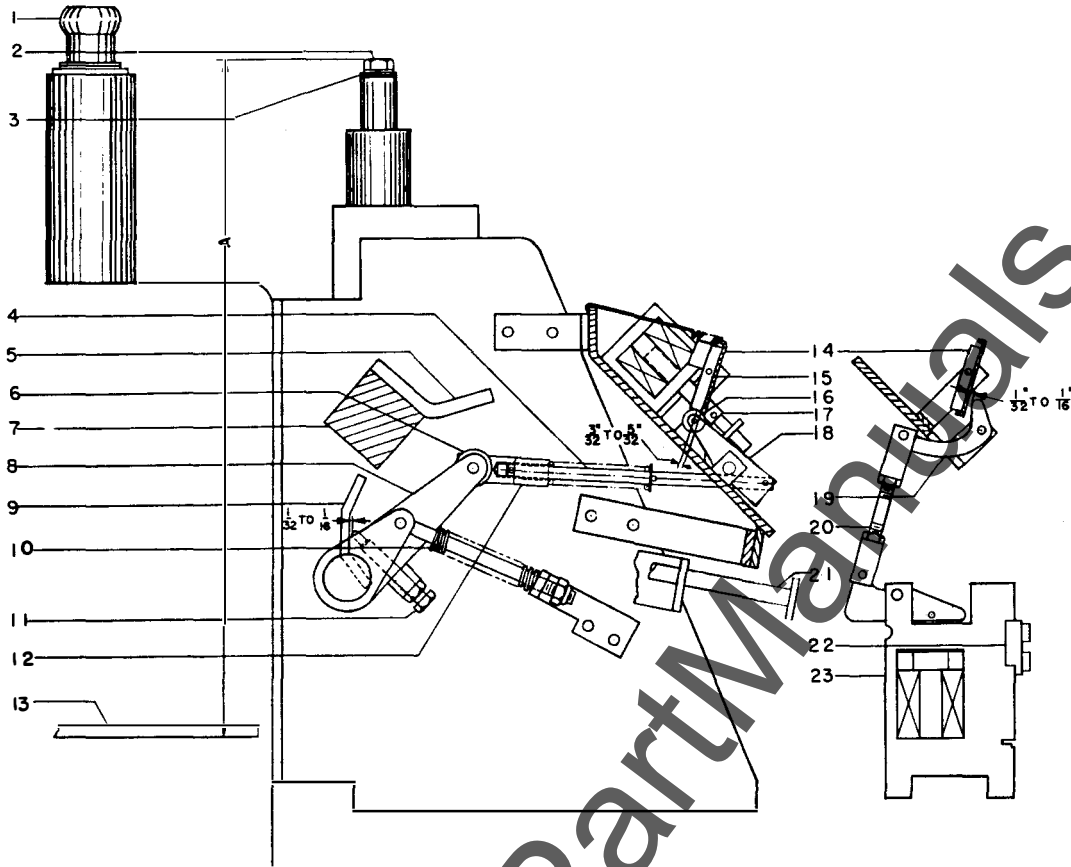

- |                          |                       |                              |
|--------------------------|-----------------------|------------------------------|
| 1. Front Disconnect Stud | 9. Trip Plate         | 17. Trip Armature            |
| 2. Interlock Bolt        | 10. Spring            | 18. Trip Lever               |
| 3. Washers               | 11. Trip Bolt         | 19. Undervoltage Trip Hammer |
| 4. Connecting Rod        | 12. Clevis            | 20. Adjusting Rod            |
| 5. Reset Plate           | 13. Elevating Bar     | 21. Manual Trip Button       |
| 6. Reset Roller          | 14. Impact Trip Plate | 22. Trip Setting Plate       |
| 7. Main Operating Shaft  | 15. Trip Latch        | 23. Undervoltage Device      |
| 8. Reset Arm             | 16. Trip Roller       |                              |

Fig. 10 Adjustments on Current Trip Device and Undervoltage Device, Shown with the Breaker in the Closed Position

*NOT on BKR*

**IMPACT TRIP, CURRENT TRIP, CAPACITOR TRIP AND UNDERVOLTAGE TRIP DEVICES.**

Fig. 8 shows the necessary settings that are to be checked when these devices are furnished. The amount of wipe between the trip roller (16) and the trip latch (15) should be  $3/32''$  to  $5/32''$ . This can be altered by changing the number of shims under the block against which the trip pan (14) stops.

In order to trip properly, the clearance between the trip bolt (11) and the trip plate (9) should be  $1/32''$  to  $1/16''$ . This can be altered by releasing the check nut and screwing the trip bolt (11) in or out of the reset arm (8).

When an undervoltage device is furnished, check the clearance between the trip hammer (19) and the trip pan (14), with the undervoltage coil energized.

This clearance should be  $1/32''$  to  $1/16''$  and can be altered by removing the connecting pin at either end of the adjusting rod assembly (20), and turning the clevis at that end.

After checking all the mechanical adjustments as outlined above, operate the devices manually to make certain that they trip and reset properly.

**PLUNGER INTERLOCK**

When furnished refer to Fig. 10. With the breaker in the closed position, the vertical distance "A" from the top of the interlock bolt (2) to the bottom surface of the elevating bar (13) should be  $11-9/32'' \pm 1/16''$ . To change this adjustment, add or remove washers (3).

Fig. 10 (T-6195074)

[www.ElectricalPartManuals.com](http://www.ElectricalPartManuals.com)

**AUXILIARY SWITCH LINKAGE**

When furnished, refer to Fig. 11 which shows the approximate location of the auxiliary switch operating pin (3). The horizontal distance from the center line of the front bushings (1) to the center of the operating pin (3) should be approximately  $13 \frac{7}{32}$ " when the breaker is in the closed position. To change this adjustment loosen the check nut (6), remove the pin (4) and turn the clevis (5). Reassemble and check the adjustment.

**FINAL INSPECTION AND TEST**

1. For ease in reviewing the adjustments, the following are recapitulated:

- ✓ a. Primary contact wipe:  $5/16"$  +0 -  $1/16"$ .
- ✓ b. Arcing contact wipe:  $5/16"$  or greater.
- ✓ c. Primary contact gap:  $5 \frac{7}{16}" + 1/8"$  -  $5/16"$ .
- ✓ d. Arcing contact clearance:  $1/8"$  minimum.
- ✓ e. Trip latch wipe:  $3/16"$  to  $1/4"$  with trip latch resting against stop pin.
- ✓ f. Prop clearance:  $1/32"$  to  $3/32"$ .
- g. Closing plunger clearance:  $1/16"$  +  $1/8"$  - 0.
- ✓ h. Latch checking switch wipe:  $1/32"$  minimum. Overtravel:  $1/32"$  minimum.
- i. Cut-off switch wipe:  $1/32"$ .
- Not on BKr j. Impact trip roller wipe:  $3/32"$  to  $5/32"$ .
- Not on BKr k. Impact trip bolt clearance:  $1/32"$  to  $1/16"$ .
- Not on BKr l. Undervoltage trip hammer clearance:  $1/32"$  to  $1/16"$ .
- ✓ m. Plunger interlock:  $11 \frac{9}{32}" + 1/16"$ .
- n. Auxiliary switch linkage:  $13 \frac{7}{32}"$ .

- 2. Check all nuts, washers, bolts, retaining rings and terminal connections for tightness.
- 3. Inspect all wiring to make sure that no damage has occurred during installation, and test for possible grounds or short circuits.
- 4. See that all bearing surfaces of the mechanism have been lubricated. Refer to the section on LUBRICATION.
- 5. Operate the breaker slowly with the maintenance operating device and note that there is no excessive binding or friction and that the breaker can be moved to the fully opened and fully closed positions.
- 6. See that any place where the surface of the paint has been damaged during installation is repainted immediately.

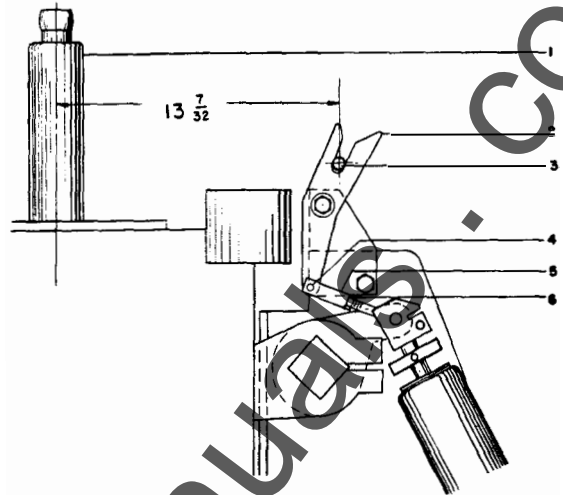

1. Front Bushing  
2. Fork Lever  
3. Operating Pin  
4. Pin  
5. Clevis  
6. Check Nut

Fig. 11 Auxiliary Switch Linkage shown with the breaker in the closed position

**HI-POTENTIAL TEST**

If the breaker had been stored for a long period of time, it is recommended that the insulation be checked before the breaker is placed in service. A standard 60 cycle high potential test at 27,000 volts RMS will normally indicate whether the breaker is satisfactory for service. With the breaker contacts in the fully opened position, apply the high potential to each terminal of the breaker individually for one minute with all other terminals and the breaker frame grounded. After high potential tests are made on organic insulation materials, these materials should be inspected for visible leakage current paths, and necessary action must be taken to replace insulation that may have been affected by moisture absorption. The high potential test is also recommended for breakers which have been removed from service and stored over an extended period of time under unfavorable atmospheric conditions.

**AUXILIARY DEVICES**

Onbreakers that are equipped with auxiliary devices such as a current trip, undervoltage trip or capacitor trip, the device should be checked for proper electrical operation. The current trip device should trip the breaker at 3 amperes. The undervoltage trip device should trip the breaker when the control voltage drops below 40 to 60% of rated voltage, and it should pick-up at 80% of the control voltage or less. An adjustment plate is provided on the front of the undervoltage trip device as an aid in obtaining the desired setting. NOTE: Voltage applied to the undervoltage device should be brought up to the pickup value within a period of 20 seconds, to avert damaging the pickup coil. The capacitor trip should be capable of tripping the

[www.ElectricalPartManuals.com](http://www.ElectricalPartManuals.com)

breaker as late as 25 seconds after the control voltage is removed. If the auxiliary devices do not perform in accordance with these specifications, a careful examination should be made for defective parts.

**CONTROL POWER CHECK**

For electrical operation of the breaker, the control power may be either an alternating or direct current source. For AC operation, two rectifiers, mounted elsewhere in the metal-clad unit, are used. A tapped resistor is provided in each AC circuit to control the DC voltage. The resistor setting should be adjusted so that the voltage at the breaker is 110 to 120 volts DC. Where repetitive operation is required, the voltage should be set at 105 to 115V. DC. This resistor should be set under normal summer conditions as described below. To check the resistor setting, proceed as follows:

1. Mechanism with a Control Device - Close the breaker by manually operating the control device contacts (5) and (6) Fig. 12). Hold these contacts in the closed position and read the DC voltage at the closing coil. To de-energize the circuit, release the control device.

2. Mechanism with Cut off Switch, Fig. 9 - Close the breaker by manually operating the control relay located in the metal-clad unit. Hold this relay closed and read the DC voltage at the closing coil terminals. Release the closing relay to de-energize the circuit.

**DO NOT MAINTAIN VOLTAGE ON THE CLOSING COIL ANY LONGER THAN THE FEW SECONDS REQUIRED TO READ THE VOLTMETER. THESE COILS ARE DESIGNED FOR INTERMITTENT OPERATION AND WILL BE DAMAGED BY PROLONGED CURRENT FLOW.**

The following tabulation is included as a guide for adjusting the resistors for the particular combination of ambient temperature and AC supply voltage. Summer settings are used where ambient temperatures are normally above freezing (32°F). It is necessary to use winter settings where the ambient temperature may drop to 20°F or less at any time. For a more detailed explanation of Copper-oxide Rectifiers for circuit breaker application refer to instruction book GEI-11306.

| AC Volts *<br>(Closed Circuit) | Resistor Setting, Ohms |        |
|--------------------------------|------------------------|--------|
|                                | Summer                 | Winter |
| 190-196                        | 1/4                    | 0      |
| 194-206                        | 1/2                    | 0      |
| 204-216                        | 1/2                    | 1/4    |
| 214-226                        | 3/4                    | 1/4    |
| 224-236                        | 1                      | 1/2    |
| 234-246                        | 1-1/4                  | 3/4    |
| 244-250                        | 1-1/4                  | 1      |

\*(AC volts as measured across rectifier and AC series resistor.)

After the breaker has been closed and opened slowly several times with the maintenance operating device, and the mechanism adjustments checked as described above, the operating voltages should be checked at the closing coil and trip coil terminals. The operating ranges for the closing and tripping voltages are given on the breaker nameplate. Ordinarily, standard ranges apply which are as follows:

| NOMINAL VOLTAGE | CLOSING RANGE | TRIPPING RANGE |
|-----------------|---------------|----------------|
| 125V. DC        | 90-130V. DC   | 70-140V. DC    |
| 250V. DC        | 180-260V. DC  | 140-280V. DC   |
| 230V. AC        | 190-250V. AC  | 190-250V. AC   |

NOTE: Where repetitive operation is required the maximum closing voltages should be 115V. DC and 230 V. DC at the nominal voltage of 125V. DC and 250 V. DC, respectively.

Electrical closing or opening is accomplished by merely energizing the closing or trip coil circuit. Control switches are provided for this purpose on the metal-clad unit. It is also possible to trip the breaker manually by pressing the manual trip button (5), Fig. 3.

When all the foregoing inspection details have been checked, the breaker may be safely placed in service. Before the breaker is finally raised into position in the metal-clad unit, rub a small amount of GE Contact Lubricant D50H28 on the silvered portion of the breaker studs to form a thin coating for contacting purposes.

NOTE: This breaker mechanism combination is designed only for electrical closing when in use. NEVER ATTEMPT MANUAL CLOSING WITH THE BREAKER IN SERVICE, for under such conditions, sufficient closing force and speed cannot be applied.

**OPERATION**

**CLOSING OPERATION**

Figs. 14 and 15 show the four basic control schemes that are used on Magne-blast breakers. The important difference between Fig. 14 and Fig. 15 is that in the circuits shown in Fig. 14, a control device is used for the closing operation whereas in Fig. 15, a cutoff switch and relay arrangement is used for the same purpose. The reason for this is because all breakers having a control circuit as

shown in Fig. 15 are designed primarily to replace breakers of older design that have similar control circuits. It may also be noted that all AC control circuits are equipped with a rectifier, which is used to convert AC power to DC power on which the closing coil operates.

Take for example the AC control circuit shown in Fig. 14 (upper). Closing of the breaker is initiated by actuating the CLOSE control switch on the metal-clad unit. Referring to Fig. 12, the control

[www.ElectricalPartManuals.com](http://www.ElectricalPartManuals.com)



device coil (3), is immediately energized, and as the control device linkage starts to move, the crank (4) closes the seal-in switch (2) which shunts the CLOSE control switch. With this arrangement, the CLOSE control switch may be released after being closed only momentarily, but the closing operation will continue until completed.

At the same time the control device contacts (5 and 6) are latched in the closed position, energizing the breaker closing coil. Refer now to Fig. 13. The closing armature (6) travels upward, raising the roller (4). This motion is transmitted through the mechanism linkage to rotate the main operating cranks (1), closing the breaker. During the closing operation, the opening springs (9 and

10) are compressed in readiness for the opening operation. At the end of the closing stroke the prop (12) engages the pin (11), latching the breaker closed. The air that is trapped above the closing armature (6) acts as a dashpot, absorbing the remaining kinetic energy of the closing armature.

The plunger (9), Fig. 3, strikes the trip lever (9), Fig. 12, to trip open the control device contacts (5 and 6). This de-energizes the closing coil permitting the closing armature to return by gravity to its original position. The seal-in switch (2) opens but the anti-pump switch (1) will not open unless the CLOSE control switch has been released. This is to prevent pumping (reclosing) when the breaker is closed against a fault.

Fig. 12 (8014743)

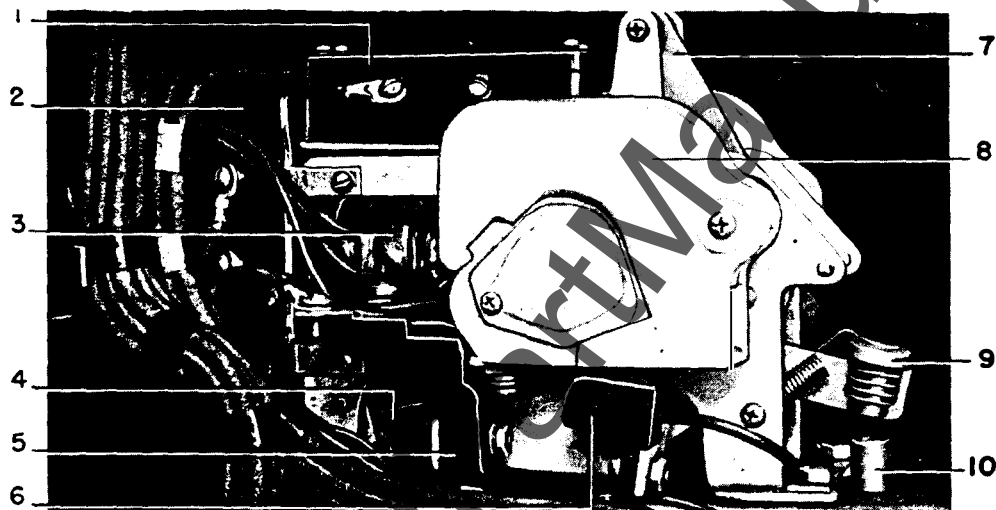

- |                                  |                             |
|----------------------------------|-----------------------------|
| 1. Shunting and Anti-pump Switch | 6. Movable Contact Assembly |
| 2. Seal-in Switch                | 7. Arm                      |
| 3. Operating Coil                | 8. Arc Quencher             |
| 4. Crank                         | 9. Trip Lever               |
| 5. Stationary Contact Assembly   | 10. Plunger Guide           |

Fig. 12 Control Device

Fig. 13 (374A293)

1. Main Crank
2. Trip Latch
3. Trip Roller
4. Closing Roller
5. Piston Ring
6. Closing Armature
7. Armature Guide Bolts
8. Spring Retainer
9. Opening Spring, Inner
10. Opening Spring, Outer
11. Closing Pin
12. Prop
13. Closing Coil
14. Closing Plunger Rod

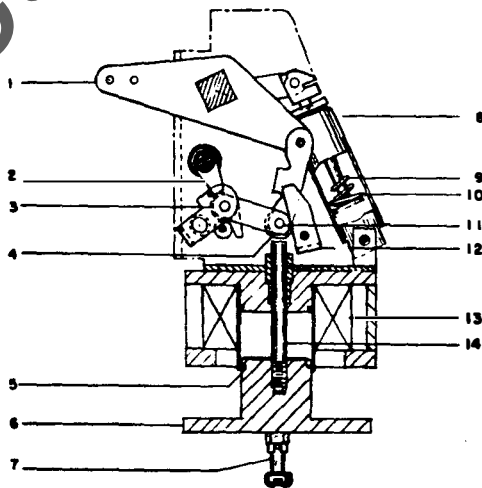
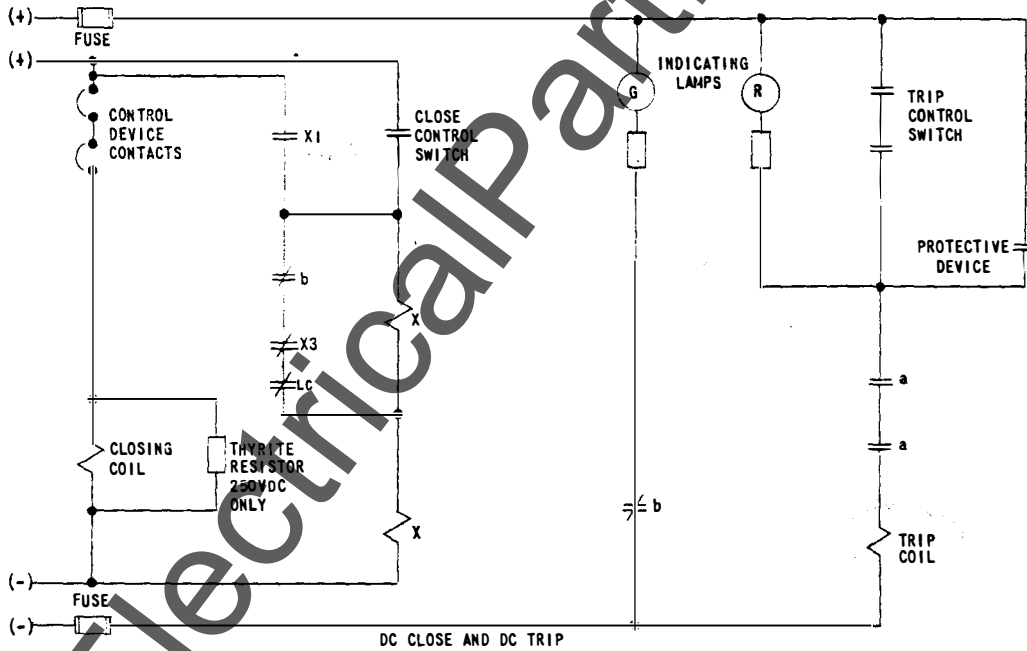
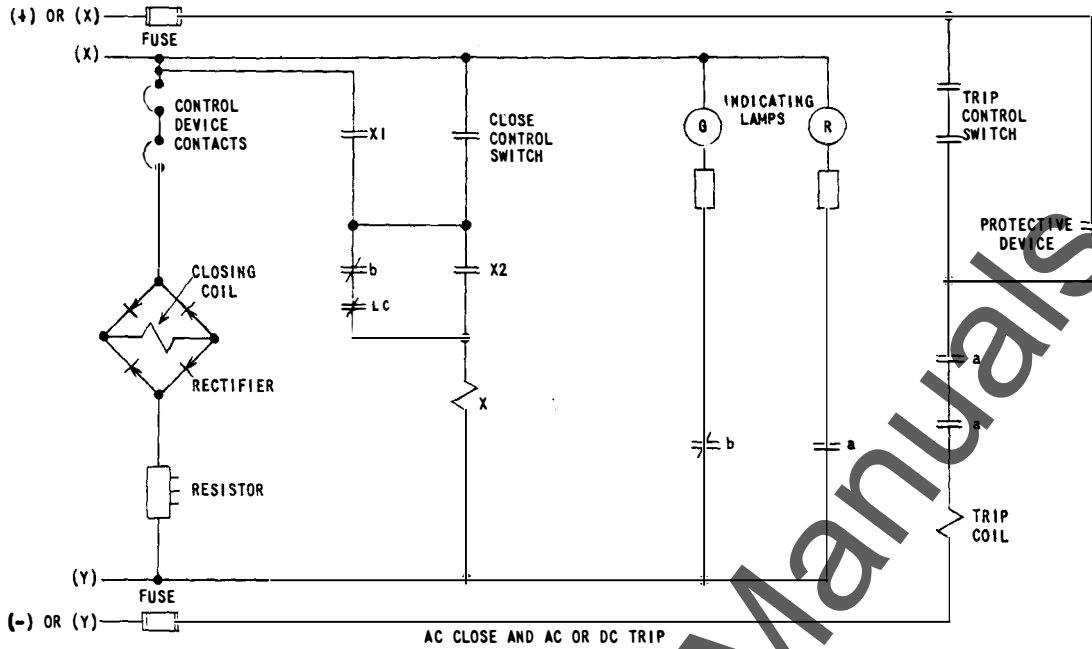

Fig. 13 Cross Section of MS-13 Operating Mechanism in the Open Position

[www.ElectricalPartManuals.com](http://www.ElectricalPartManuals.com)



- a NORMALLY OPEN AUXILIARY SWITCH
- b NORMALLY CLOSED AUXILIARY SWITCH
- LC LATCH CHECKING SWITCH (FOR RECLOSING OPERATION)
- X CONTROL DEVICE OPERATING COIL
- X1 CONTROL DEVICE SEAL-IN CONTACTS
- X2 CONTROL DEVICE ANTI-PUMP CONTACTS
- X3 CONTROL DEVICE SHUNTING CONTACTS (ALSO ANTI-PUMP)

Fig. 14 Typical Elementary Wiring Diagrams (Shown in the De-energized Position) for Magne-blast Breakers Types AM-7.2-1, AM-13.8-1, and AM-13.8-B-1

[www.ElectricalPartManuals.com](http://www.ElectricalPartManuals.com)

Fig. 15 (7023816)

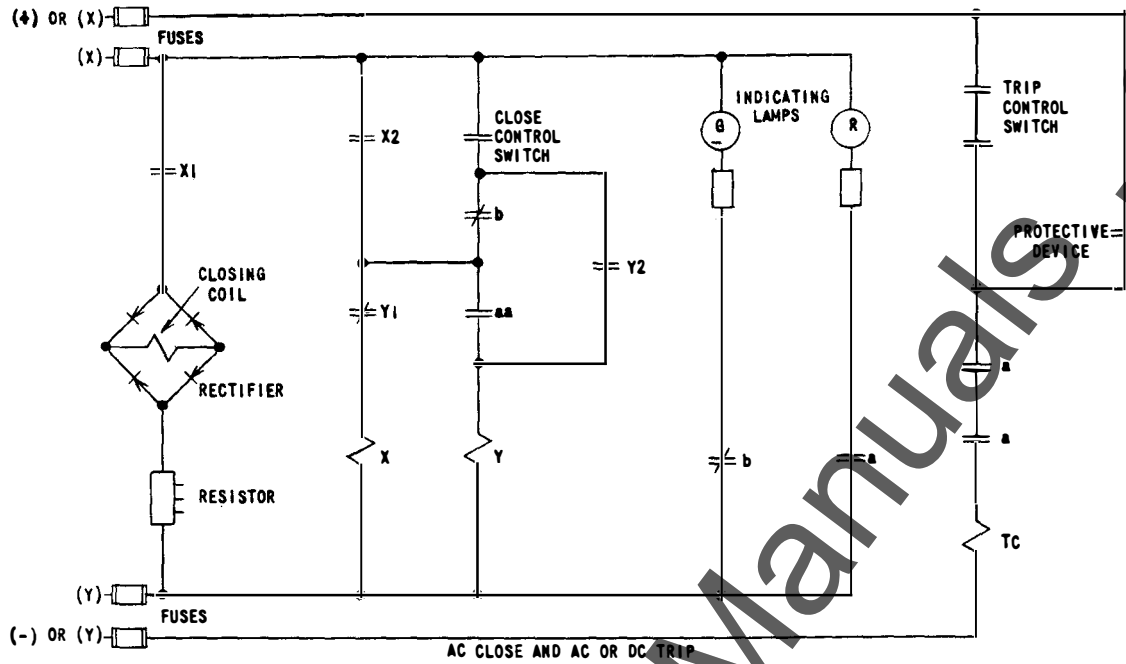

AC CLOSE AND AC OR DC TRIP

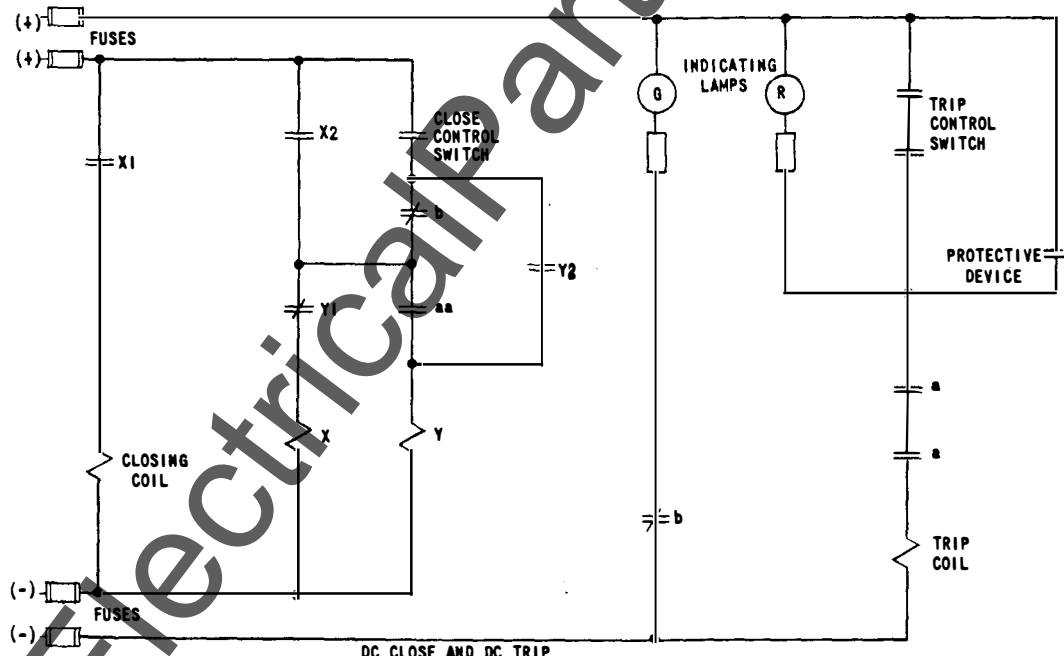

DC CLOSE AND DC TRIP

- a NORMALLY OPEN AUXILIARY SWITCH
- b NORMALLY CLOSED AUXILIARY SWITCH
- aa CUT-OFF SWITCH
- X CLOSING RELAY COIL
- X1 RELAY CLOSING CONTACTS
- X2 RELAY SEAL-IN CONTACTS
- Y AUXILIARY RELAY COIL
- Y1 AUXILIARY RELAY CUT-OFF CONTACTS
- Y2 AUXILIARY RELAY ANTI-PUMP CONTACTS

Fig. 15 Typical Elementary Wiring Diagrams (Shown in the De-energized Position) for Magne-blast Breakers Types AM-7.2-A-1, AM-13.8-A-1, and AM-13.8-AB-1

[www.ElectricalPartManuals.com](http://www.ElectricalPartManuals.com)

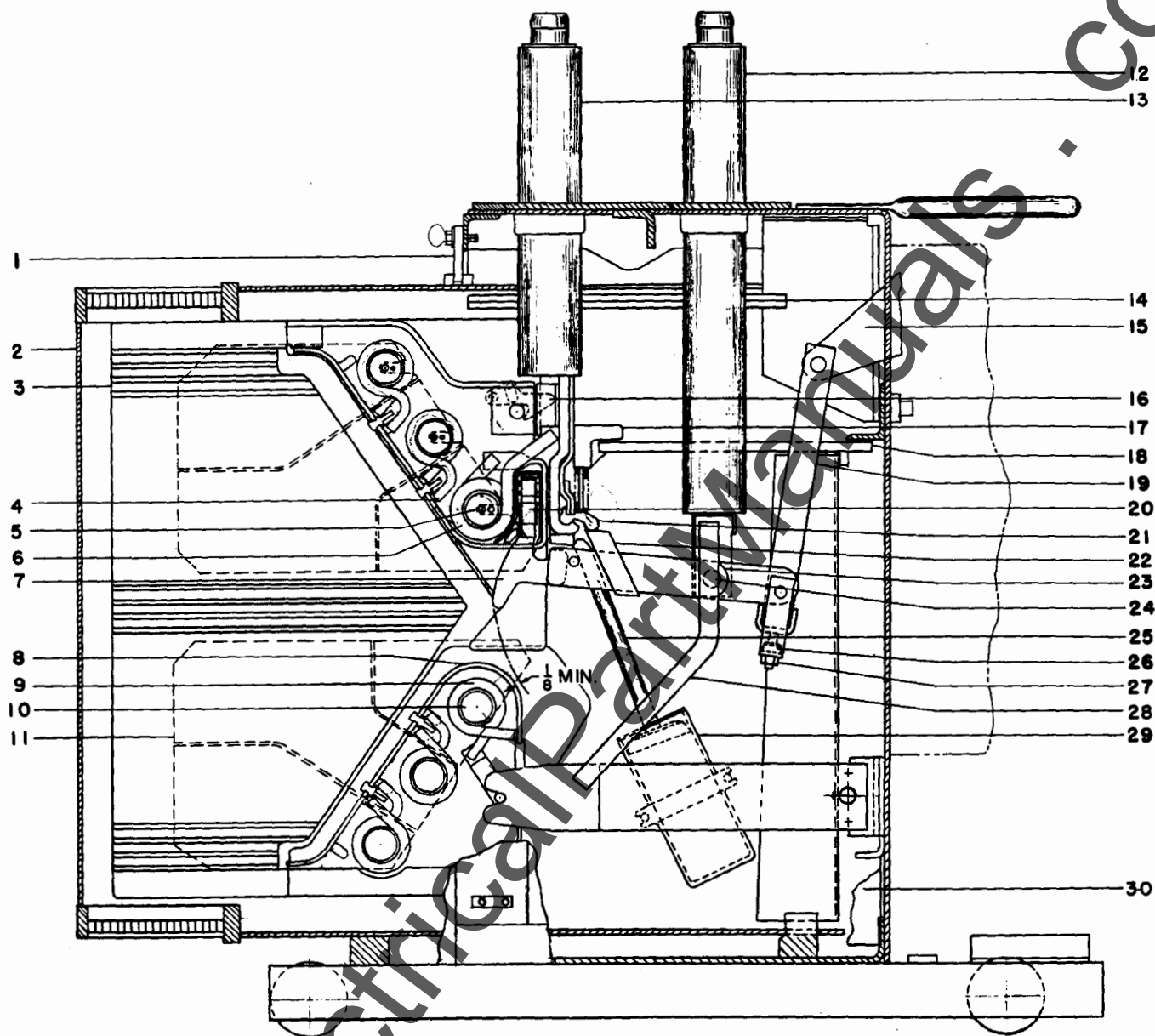

Fig. 16 (2150442)

- |                           |                               |                                  |
|---------------------------|-------------------------------|----------------------------------|
| 1. Box Barrier Catch      | 11. Pole Pieces               | 21. Stationary Primary Contact   |
| 2. Box Barrier            | 12. Front Bushing             | 22. Movable Primary Contact      |
| 3. Arc Chute              | 13. Rear Bushing              | 23. Movable Contact Arm Assembly |
| 4. Arc Runner, Upper      | 14. Upper Horizontal Barrier  | 24. Cup Bearing                  |
| 5. Blow Out Core, Upper   | 15. Main Operating Crank      | 25. Booster Tube                 |
| 6. Blow Out Coil, Upper   | 16. Arc Chute Catch           | 26. Thumb Screw                  |
| 7. Movable Arcing Contact | 17. Spring Retainer           | 27. Check Nut                    |
| 8. Arc Runner, Lower      | 18. Lower Horizontal Barrier  | 28. Connection Bar               |
| 9. Blow Out Coil, Lower   | 19. Operating Rod             | 29. Booster Cylinder and Piston  |
| 10. Blow Out Core, Lower  | 20. Stationary Arcing Contact | 30. Side Barrier                 |

Fig. 16 Cross Section of Breaker Pole Unit

[www.ElectricalPartManuals.com](http://www.ElectricalPartManuals.com)



The closing speed of the arcing contacts through the arcing zone should be within the range of 10 to 18 feet per second, at rated control voltage.

## OPENING OPERATION

An electrical opening operation is initiated by energizing the trip circuit, which is accomplished either by actuating the opening control switch on the Metal-clad unit or by a combination of relays and current devices used to detect a fault on the load side of the breaker. By energizing the trip coil, the trip plunger rotates the trip latch (2), Fig. 13, causing the operating mechanism linkage to collapse. The energy stored in the opening springs (9 and 10) is thus released, opening the breaker. During this operation the trip coil circuit is de-energized, and upon completion of the opening operation, the operating mechanism is returned to its normal position, ready for closing.

As the breaker opens, the main contacts part first, shunting the current through the arcing contacts. An arc forms as the arcing contacts part. See Fig. 16. As the movable arcing contact (7) is withdrawn through the slot in the arc runner, the upper end of the arc is transferred to the upper arc runner (4). To assist the interruption of low currents at this point, a stream of air is emitted from the booster outlet (25) and forces the arc into the arc chute. Establishment of the arc on the runners automatically inserts the blow-out coils (6 and 9) into the circuit, introducing a magnetic field between the pole pieces which tends to draw the arc away from the arcing contacts. The arc chute contains three upper and three lower magnetic blow-out coils electrically connected in series and each individually

connected to a segment of the arc runners. As the arc is forced outward along the diverging arc runners, by the magnetic field, the arc transfers from one segment of the arc runners to the next. By this action, each succeeding pair of blow-out coils is inserted into the circuit to produce an additional magnetic force to drive the arc on.

At the same time, the arc is being forced into the arc chute (3), which is composed of a series of gradually interleaving insulating fins. These fins, which project alternately from the two opposite inner surfaces of the chute, elongate the arc into a gradually deepening serpentine path, so that the electrical resistance in the path of the arc is rapidly increased and the heat from the arc is absorbed. The increased resistance reduces both the magnitude and the phase angle of the current, and at an early current zero the arc path is so long and the gases produced by the arc so cooled that the arc cannot re-establish itself, and interruption occurs.

The opening speed of the arcing contacts through the arcing zone should be within the range of 10 to 18 feet per second, at rated control voltage.

Manual tripping follows the same procedure except that instead of energizing the trip circuit, the manual trip (5), Fig. 3 is used.

## TRIP FREE OPERATION

If the trip coil circuit is energized while the breaker is closing, the trip plunger will force the trip latch (2), Fig. 13, away from the trip roller (3) causing the mechanism linkage to collapse and the breaker to re-open. The closing armature (6) completes its closing stroke, but the closing coil is de-energized at the end of the stroke, and the armature is returned to its original position.

## MAINTENANCE

Dependable service and safety of power equipment are contingent upon the unfailing performance of the power circuit breaker. To maintain such service, it is recommended that a definite inspection and maintenance schedule be set up and followed, as serious shutdown can often be avoided by locating potential sources of trouble in an early stage. A periodic lubrication of parts subject to wear is also vitally important for the successful operation of the breaker.

**NOTE:** Before any maintenance work is performed make certain that all control circuits are de-energized and that the breaker primary circuits are open and effectively grounded. Also, do not work on the breaker or mechanism while in the closed position unless the prop and trip latch have been securely wired or blocked to prevent accidental tripping.

## PERIODIC INSPECTION

The frequency of periodic inspections should be determined by each operating company on the basis of the number of operations (including switching), the magnitude of currents interrupted, and any unusual operations which occur from time to time. Operating experience will soon establish a mainten-

ance schedule which will give assurance of proper breaker condition. On installations where a combination of fault duty and repetitive operation is encountered, an inspection is recommended after any severe fault operation. The following instructions list the main points to be included in an inspection, and a number of general recommendations.

### ARC CHUTES

It is not necessary to inspect the arc chutes unless there is evidence of damage or if the arc chutes are removed for any reason. When inspecting an arc chute, it should be disassembled and the following points noted:

1. Scale formed over the surface of the chute must not be removed, but loose particles collected in the chute should be blown out.
2. Cracks which have formed in the fins of the arc chute are to be expected in ceramic materials of this type when subjected to the severe heat of an arc. These cracks do not interfere with the operation of the device in any way and should be disregarded.

[www.ElectricalPartManuals.com](http://www.ElectricalPartManuals.com)

- If the chute has suffered any mechanical injury due to dropping or accidental striking, resulting in the actual breaking off of fins, replacement of the chute will be necessary.

**BREAKER CONTACTS**

By removing the box barriers (3) and side barriers (4), Fig. 5, the movable and stationary primary contacts and the movable arcing contacts can be inspected. The stationary arcing contacts can be inspected only after removing the arc chutes and the arc runner side barriers (11), Fig. 21, as explained under REPAIR AND REPLACEMENT. If the contacts are burned or pitted, they should be made smooth with a fine file.

After completing inspection of the contacts, check the contact adjustments as specified under INSTALLATION, ADJUSTMENTS.

**MECHANISM**

A careful inspection should be made to check for loose nuts or bolts and broken retaining rings. All cam, roller, and latch surfaces should be inspected for any evidence of damage or excessive wear. Lubricate the mechanism as outlined below, then, using the maintenance operating device, open and close the breaker several times to make certain that the mechanism operates freely throughout its entire stroke. Check the mechanism adjustments as specified under INSTALLATION, ADJUSTMENTS. Check all terminal connections.

**BUSHINGS AND INSULATION**

The surface of the \*Herkolite bushings should be kept clean and unmarred to prevent moisture absorption. If the insulation surface should become damaged, it should be sanded and cleaned, and should be refinished with either clear varnish (GE-1170), clear \*Glyptal (GE-1202), or brown \*Glyptal (GE-1210). Allow to dry smooth and hard.

All other insulation parts on the breaker should be kept clean and dry. Smoke or dust collected between inspection periods should be wiped off, and if dampness is apparent, heaters should be installed to insure dryness.

**LUBRICATION**

In order to maintain reliable operation, it is important that all circuit breakers be properly lubricated at all times. During assembly at the factory, all bearings surfaces, machined surfaces, and all other parts of the breaker and mechanism subject to wear have been properly lubricated using the finest grade of lubricants available. However, even the finest oils and greases have a tendency to oxidize with age, as evidenced by hardening and darkening in color. Elimination of the hardened lubricants therefore, is essential for the proper operation of the circuit breaker. Furthermore, frequent operation of the breaker causes the lubricant to be forced out from between the bearing surfaces. A simple lubrication will often clear up minor disturbances which might be mistaken for more serious trouble.

A definite lubrication schedule should be set up, taking into consideration the frequency of operation of the breaker and local conditions. Until such a schedule is worked out, the breaker should be lubricated at each periodic inspection and also whenever it is overhauled, in accordance with the lubrication chart, Fig. 17. It is also recommended that all circuit breakers be operated at regular intervals to insure the user that the equipment is operating freely.

The lubrication chart is divided into two methods of lubrication. The first method outlines the maintenance lubrication which should be performed at the time of periodic maintenance, and requires no disassembly. The second method outlines a lubrication procedure similar to that performed on the breaker at the factory, but should be used only in case of a general overhaul or disassembly for other reasons, or if the operation of the breaker becomes slower.

| Part  | Lubrication At Maintenance Period                         | Alternative Lubrication (Requires Disassembly)   |
|---|---|--|
| Ground surfaces such as cams, rollers, latches, etc.          | Wipe clean and apply D50H15                               | Wipe clean and apply D50H15  |
| Booster cylinder  | Wipe clean and apply thin film of D50H15                  | Wipe clean and apply thin film of D50H15   |
| Sleeve Bearings (Mechanism and Breaker Linkage)               | Very light application of light machine oil SAE-20 or -30 | Remove pins and links and clean as per cleaning instructions below. Apply D50H15 Liberally |
| Removable Seal and Open Type Ball, Roller and Needle Bearings | Light application of light machine oil SAE-20 or -30      | Clean as per cleaning instructions below and repack with D50H15                            |
| Silver Plated Contacts and Primary Disconnect Studs           | Wipe clean and apply D50H28<br>D50H38                     | Wipe clean and apply D50H28  |

Fig. 17 Lubrication Chart

[www.ElectricalPartManuals.com](http://www.ElectricalPartManuals.com)

General Electric Lubricant D50H15 is available only in cartons containing twelve collapsible tubes of grease. This is a total of three pounds of grease to the carton. It is so packaged to insure cleanliness and to prevent oxidation.

#### METHOD OF CLEANING BEARINGS

Wherever cleaning is required, as indicated in the lubrication chart, the following procedures are recommended:

##### Sleeve Bearings

The pins should be removed and all old oxidized grease removed by immersion in clean petroleum solvent or similar cleaner. **DONOT USE CARBON-TETRACHLORIDE.** Wipe the bearing clean, then apply a small amount of G.E. Lubricant D50H15 to the entire surface of the bearing just before re-assembling.

##### Removable Seal and Open Type Ball, Roller and Needle Bearings

The bearings should be first removed from the mechanism and disassembled by the removal of the seals or inner race in the case of needle bearings. They should then be placed in a container of clean petroleum solvent or similar cleaner. **DONOT USE CARBON-TETRACHLORIDE.** If the grease in the bearings has become badly oxidized it may be necessary to use alcohol (the type used for thinning shellac) to remove it. Ordinarily, by agitating the bearings in the cleaning solution and using a stiff brush to remove the solid particles, the bearings can be satisfactorily cleaned. Do not handle the bearings with bare hands as deposits from the skin onto the bearings are conducive to corrosion. If the bearings are touched, the contamination can be removed by washing in alcohol. After the bearings have been thoroughly cleaned, spin them in clean new light machine oil until the cleaner or solvent is entirely removed. Allow this oil to drain off and then repack them immediately with G.E. Lubricant D50H15 being sure all metal parts are greased. The removable seals should then be replaced.

**NOTE:** If it becomes necessary to clean the bearings in alcohol (shellac thinner) be sure the alcohol is perfectly clean, and do not allow the bearings to remain in the alcohol more than a few hours. If it is desirable to leave the bearings in the alcohol for a longer time, an inhibited alcohol such as is used for anti-freeze should be used. Even then the bearings should be removed from the alcohol within twenty-four hours. Esso Anti-freeze and DuPont Zerone are satisfactory for this purpose. Precautions against the toxic effects of the alcohol must be exercised by wearing rubber gloves and by using the alcohol in a well ventilated room; excessive exposure to the fumes is sometimes unpleasant to personnel. Washing the bearings in light oil and draining should follow immediately, then apply the lubricant.

## TROUBLE SHOOTING

Failure of a breaker to operate properly will generally fall within three general classes: Failure to trip, failure to close or latch closed, and overheating. The following is a brief outline showing particular types of distress that might be encountered, together with suggestions for remedying the trouble.

### FAILURE TO TRIP

1. Mechanism binding or sticking caused by lack of lubrication.  
REMEDY: Lubricate complete mechanism
2. Mechanism binding or sticking caused by being out of adjustment.  
REMEDY: Check all mechanism adjustments, latches, stops, auxiliary devices, etc. in accordance with **INSTALLATION, ADJUSTMENTS.** Examine latch and roller surfaces for corrosion.
3. Damaged trip coil.  
REMEDY: Replace damaged coil.
4. Blown fuse in trip circuit.  
REMEDY: Replace blown fuse after determining cause of failure.
5. Faulty connections in trip circuit.  
REMEDY: Repair broken or loose wires and see that all binding screws are tight.
6. Damaged or dirty contacts in trip circuit.  
REMEDY: Recondition or replace contacts.

### FAILURE TO CLOSE OR LATCH CLOSED

1. Mechanism binding or sticking caused by lack of lubrication.  
REMEDY: Lubricate complete mechanism
2. Mechanism binding or sticking caused by being out of adjustment.  
REMEDY: Check all mechanism adjustments, latches, stops auxiliary devices, etc. in accordance with **INSTALLATION, ADJUSTMENTS.** Examine latch and roller surfaces for corrosion.
3. Control device sticking or not operating properly.  
REMEDY: Check and adjust control device, or replace.
4. Damaged or dirty contacts in control circuit, including control device.  
REMEDY: Recondition or replace contacts
5. Damaged control device coil.  
REMEDY: Replace damaged coil
6. Damaged closing coil.  
REMEDY: Replace damaged coil
7. Defective cut-off switch or latch-checking switch.  
REMEDY: Replace defective switch.

[www.ElectricalPartManuals.com](http://www.ElectricalPartManuals.com)

8. Blown fuse in closing circuit.  
REMEDY: Replace blown fuse after determining cause of failure.
9. Faulty connections in closing circuit  
REMEDY: Repair broken or loose wires see that all binding screws are tight.
10. Insufficient control voltage caused by excessive drop in leads.  
REMEDY: Install larger wires and improve electrical contact at connections.
11. Insufficient control voltage caused by poor regulation (AC control).  
REMEDY: Install larger control transformer. Check rectifier to be sure it is delivering adequate DC supply.

#### OVERHEATING

1. Poor condition of contacts due to lack of attention after severe duty or too frequent operation.  
REMEDY: Recondition or replace burned and pitted contacts. (Contacts should be reconditioned very carefully and only when absolutely necessary.)
2. Contacts not properly aligned or adjusted.  
REMEDY: Check all adjustments in accordance with INSTALLATION ADJUSTMENTS
3. Breaker kept closed or open for too long a period.  
REMEDY: Operate more often to wipe contacts clean. Replace contacts if necessary.
4. Overloading  
REMEDY: Replace breaker with one of adequate rating for present or future load, or rearrange circuits so as to remove excess load.
5. Primary connections of inadequate capacity,  
REMEDY: Increase size or number of conductors or remove excess current.
6. Loose connections or terminal connectors.  
REMEDY: Tighten all connections.
7. Ambient temperature too high.  
REMEDY: Relocate in a cooler place, or arrange some means of cooling.

#### REPAIR AND REPLACEMENT

The following information covers in detail the proper method of removing various parts of the breaker in order to make any necessary repairs. This section includes only those repairs that can be made at the installation on parts of the breaker that are most subject to damage or wear.

**IMPORTANT:** UPON COMPLETION OF ANY REPAIR WORK ALL BREAKER AND MECHANISM ADJUSTMENTS MUST BE CHECKED. Refer to the section on INSTALLATION, paying particular attention to ADJUSTMENTS AND FINAL INSPECTION.

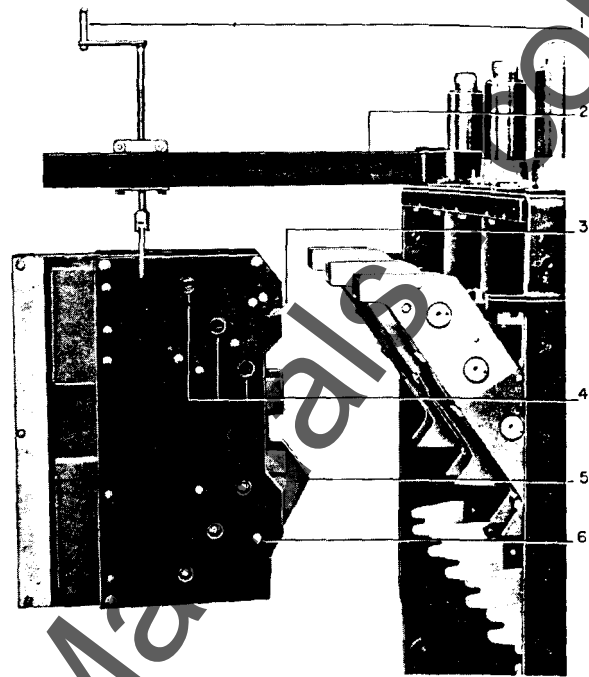

- |                      |                       |
|----------------------|-----------------------|
| 1. Crank             | 4. Mounting Holes     |
| 2. Arc Chute Remover | 5. Arc Chute Assembly |
| 3. Support Catches   | 6. Mounting Stud      |

Fig. 18 Method of Removing Arc Chute  
ARC CHUTES AND LOWER ARC RUNNERS

To remove an arc chute, first open the breaker and remove the box barrier (3) and side barrier (4), Fig. 1. Then attach the arc chute remover to the breaker frame as shown in Fig. 18, using one of the bushing mounting bolts to hold the device in place. Insert the lifting hooks into the arc chute lifting holes and take up the slack by turning the crank (1). Remove the mounting hardware at (4) and (6) and release the support catches (3). Then pull the arc chute (5) out of the breaker.

To disassemble the arc chute after it has been removed from the breaker, refer to Fig. 19 and proceed as follows:

1. Remove the assembly hardware (1, 2, 3, and 4) and lift off the arc chute upper half (5).
2. Remove the blow-out cores (12). The arc chute side (8) may now be removed if necessary.
3. Remove the assembly hardware (9, 14, 11, and 13) in the order given, so as to remove the side piece (10) and the piece of insulation under it. Each arc runner segment or blow-out coil may now be removed.
4. Reassemble in the reverse order. Before tightening the assembly hardware, arrange the two halves of the arc chute so that the fins are equally spaced. When installing the

[www.ElectricalPartManuals.com](http://www.ElectricalPartManuals.com)



Fig. 20 (8011923)

Fig. 19 (8016468) & (8010674)

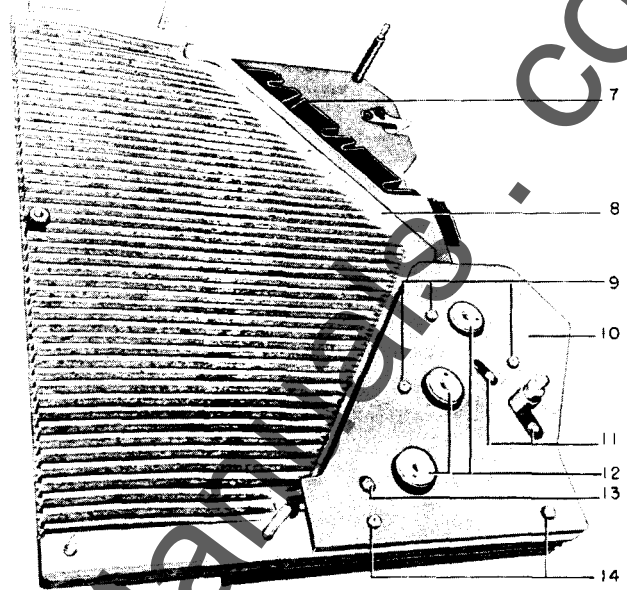
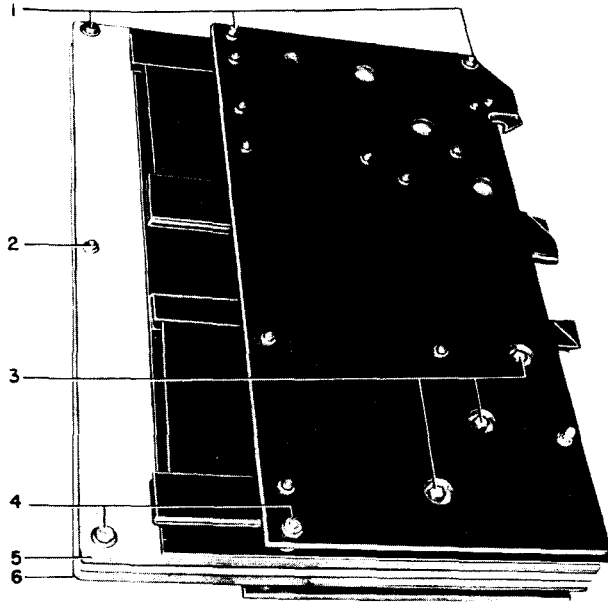

- |                         |                                  |
|-------------------------|----------------------------------|
| 1. Nuts                 | 8. Arc Chute Side                |
| 2. Nut                  | 9. Nuts                          |
| 3. Bolts                | 10. Glass Bonded Mica Side Piece |
| 4. Nuts                 | 11. Nuts                         |
| 5. Arc Chute Upper Half | 12. Blow-out Cores               |
| 6. Arc Chute Lower Half | 13. Nut                          |
| 7. Pole Pieces          | 14. Nuts                         |

Fig. 19 Disassembly of Arc Chute

arc chute in the breaker, check the 1/8" minimum clearance to the movable arcing contact as shown in Fig. 16 before tightening the mounting bolts.

**CONTACTS**

1. Open the breaker and remove the box barriers and side barriers (4), Fig. 1.
2. To remove the stationary primary contacts Fig. 20, compress and remove the contact springs (3), raise the contact fingers (4) and slide them out. When reassembling apply a thin coating of D50H28 grease to the hinged portion of the contacts.
3. Remove the two bolts (7) to remove the movable primary contacts (6).
4. Remove the two bolts (8) to remove the movable arcing contact (9).
5. To remove the stationary arcing contacts (19), Fig. 21, first remove the arc chute as described above and remove the side pieces (11). Remove the screw holding the contact braid (16), then turn the contacts 90 degrees and pull out the arcing contact finger assembly.
6. Reassemble in the reverse order, then check all contact adjustments described under INSTALLATION, ADJUSTMENTS.

**BUSHINGS**

**IMPORTANT: DO NOT REMOVE ALL SIX BUSHINGS AT ONCE.** The bushings have been care-

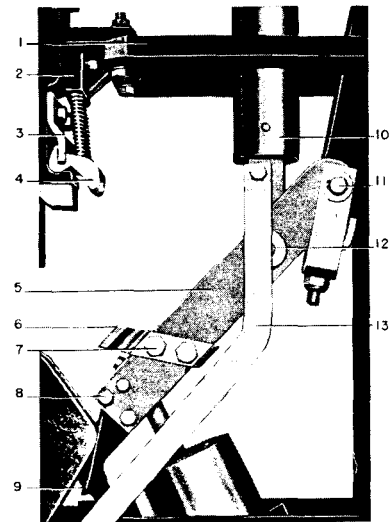

- |                             |                    |
|-----------------------------|--------------------|
| 1. Lower Horizontal Barrier | 7. Assembly Bolts  |
| 2. Spring Retainer          | 8. Assembly Bolts  |
| 3. Contact Springs          | 9. Arcing Contact  |
| 4. Primary Contacts         | 10. Front Bushing  |
| 5. Contact Arm              | 11. Pin            |
| 6. Primary Contacts         | 12. Cup Bearing    |
|                             | 13. Connection Bar |

Fig. 20 Connection Bar

[www.ElectricalPartManuals.com](http://www.ElectricalPartManuals.com)

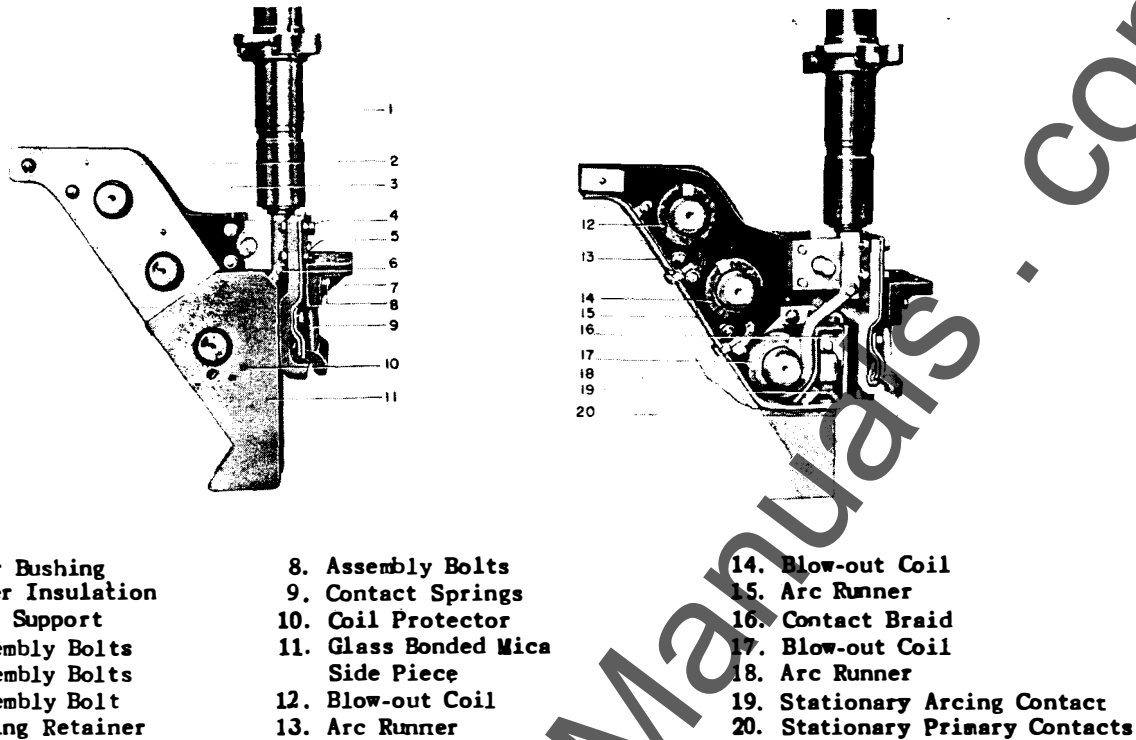

Fig. 21 Disassembly of Upper Arc Runner Unit

fully aligned with the breaker frame, during assembly at the factory, and it is important that this alignment be maintained to facilitate installation of the breaker in the Metal-clad unit. It is therefore recommended that the bushings be removed and reassembled one-at-a-time. Also, before removing any one bushing, measure the distance from that particular bushing to adjacent bushings in both directions, so that it may be reinstalled in the same location.

It is also possible to remove and reassemble three bushings at one time. If this is preferred, alignment of the bushings may be accomplished by placing the breaker in a de-energized spare Metal-clad unit before tightening the bushing mounting bolts. This must be done before the arc chutes are reinstalled.

Rear Bushing and Arc Runner Assembly

1. Open the breaker and remove the box barriers and arc chutes as already described.
2. Remove the upper and lower horizontal barriers (14 and 18), Fig. 16.
3. Remove the four bolts at the mounting flange of the rear bushing being removed, and lower the bushing and arc runner assembly.
4. For further disassembly refer to Fig. 21. Remove the bolts (8) and spring retainer (7). Remove the bolts (5 and 6) to remove the bushing (1). The stationary primary contacts (10) may also be removed if necessary.

5. Remove the upper and lower side pieces (2 and 11) and the insulation (3), making it possible to remove the arc runner segments and blow-out coils.

6. Reassemble in the reverse order.

Front Bushings

1. Open the breaker and remove the box barriers and arc chutes as already described.
2. Remove the upper and lower horizontal barriers (14 and 18), Fig. 16.
3. Referring now to Fig. 20, remove the connection bar (13) and cup bearing (12).
4. Remove the four bolts at the mounting flange of the front bushing being removed, and lower the bushing.
5. When reassembling, first mount the bushing and assemble the cup bearing (12) and contact arm (5), Fig. 20. The contact surfaces at the hinged point of the contact blade and bushing should have a thin coating of D50H28 grease.
6. Reassemble and check all contact adjustments outlined under INSTALLATION ADJUSTMENTS.

CLOSING COIL

The closing coil is contained within the sol-

Fig. 21 (8016469) & (8016470)

[www.ElectricalPartManuals.com](http://www.ElectricalPartManuals.com)

Fig. 22 (8014737)

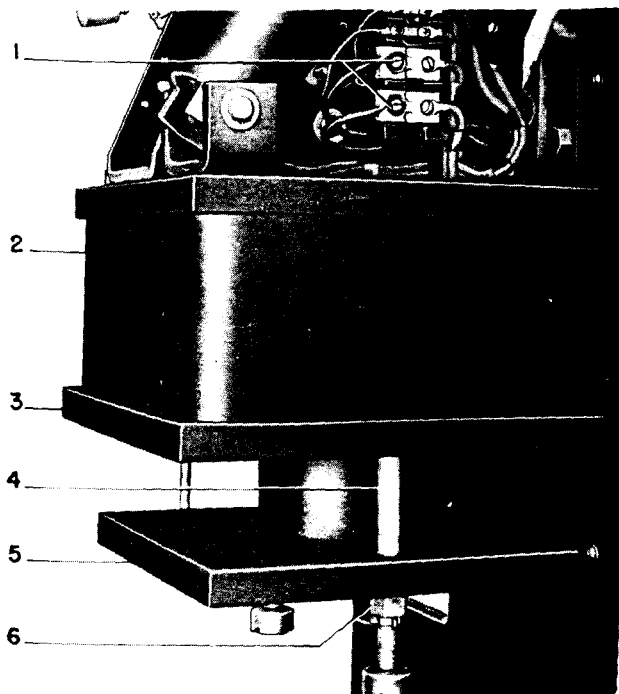

- |                            |                     |
|----------------------------|---------------------|
| 1. Closing Coil Lead Wires | 4. Guide Bolts      |
| 2. Solenoid Pot            | 5. Closing Armature |
| 3. Bottom Plate            | 6. Stop Nuts        |

Fig. 22 Closing Solenoid Assembly

enoid pot (2) Fig. 22. To remove the closing coil proceed as follows:

1. Open the breaker.
2. Remove the two stop nuts (6), allowing the armature (5) to be lowered from the mechanism.
3. Disconnect the two closing coil lead wires (1).
4. Dismantle the terminal board, which is mounted on the opposite side of the solenoid pot (2).
5. Loosen slightly the four nuts under the bottom plate (3) that hold the pole piece to the mechanism. This permits the solenoid pot (2) to be removed by sliding it forward.
6. Remove the four nuts, to lower the bottom plate (3) and closing coil.
7. Reassemble in the reverse order, then check the mechanism adjustments as explained under INSTALLATION ADJUSTMENTS.

#### TRIP COIL

To replace the potential trip coil (3), Fig. 23 proceed as follows:

Fig. 23 (8014739)

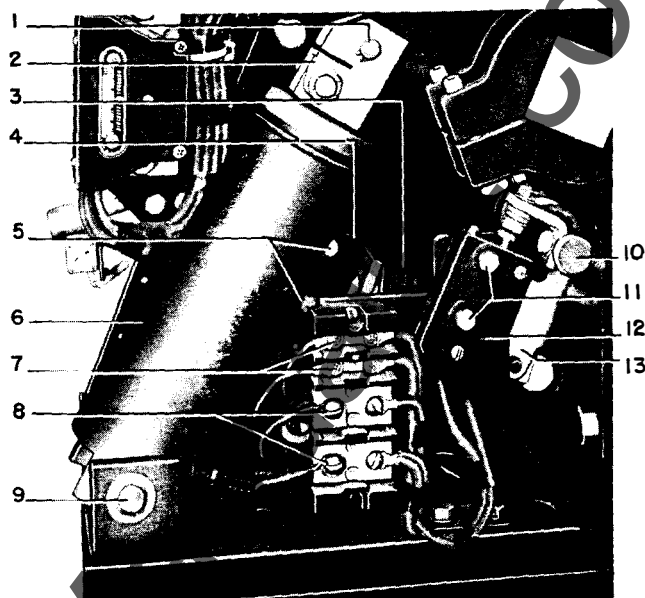

- |                        |                           |
|------------------------|---------------------------|
| 1. Pivot Pin           | 8. Closing Coil Leads     |
| 2. Clevis              | 9. Pivot Pin              |
| 3. Trip Coil           | 10. Trip Shaft            |
| 4. Trip Coil Support   | 11. Bolts                 |
| 5. Mounting Bolts      | 12. Latch Checking Switch |
| 6. Opening Spring Unit | 13. Trip Lever            |
| 7. Trip Coil Leads     |                           |

Fig. 23 Latch Checking Switch and Potential Trip

1. Open the breaker and remove the opening spring pivot pin (1) and pull the opening spring unit (6) forward out of the way.
2. Disconnect the two trip coil lead wires (7).
3. Remove the two mounting bolts (5) and the trip coil support (4).
4. Remove the trip coil (3).
5. After reassembling in the reverse order check the primary contact gap adjustment as explained under INSTALLATION ADJUSTMENTS.

#### LATCH CHECKING SWITCH

To remove the latch checking switch (12), Fig. 23 remove the two mounting bolts (11) and disconnect the lead wires. When remounting the switch, adjust the latch checking switch wipe as explained under INSTALLATION ADJUSTMENTS.

#### CUT-OFF SWITCH

To remove the cut-off switch (1), Fig. 7, remove the two mounting bolts and disconnect the lead wires. When reassembling, check the cut-off switch adjustments as explained under INSTALLATION ADJUSTMENTS.

[www.ElectricalPartManuals.com](http://www.ElectricalPartManuals.com)

## RENEWAL PARTS

### RECOMMENDATIONS

It is recommended that sufficient renewal parts be carried in stock to enable the prompt replacement of any worn, broken, or damaged parts. A stock of such parts minimizes service interruptions caused by breakdowns, and saves time and expense. When continuous operation is a primary consideration, more renewal parts should be carried, the amount depending upon the severity of the service and the time required to secure replacements.

A complete list of renewal parts is contained in the Renewal Parts Bulletins GEF-3874 (for AM-7.2) and GEF-3875 (for AM-13.8). Those parts subject to wear in ordinary operation, and to damage or breakage due to possible abnormal conditions, are marked as recommended renewal parts.

### ORDERING INSTRUCTIONS

When ordering renewal parts, address the nearest General Electric Sales Office, specifying the quantity required, and describing each part by the catalog number obtained from the Renewal Parts Bulletin.

It is also suggested that complete identification of the breaker be furnished by supplying the information found on the breaker nameplate and, if possible, the number of the requisition on which the breaker was originally furnished.

Renewal parts which are furnished may not be identical to the original parts, since improvements are made from time to time. The parts which are furnished, however, will be interchangeable.

[www.ElectricalPartManuals.com](http://www.ElectricalPartManuals.com)