



Power Break® II Circuit Breaker Accessories

Auxiliary Switch Module

Introduction

The Auxiliary Switch Module, shown in Figure 1 for stationary breakers and Figure 2 for draw-out breakers, can be installed in 800–4000 ampere frame Power Break® II circuit breakers. Auxiliary switches provide remote indication of breaker main contact position through terminals on the left side of the breaker.

Auxiliary Switch Modules are available with 4, 8, and 12 switches with ratings of 6 A at 240 Vac or 600 Vac. Additional ratings of 0.5 A at 125 Vdc and 0.25 A at 250 Vdc apply to all models. Catalog numbers are listed in Table 1 for stationary breakers and Table 2 for draw-out breakers. Note that these catalog numbers are for the field-installable kits. Delete the final “R” from the catalog number when ordering an auxiliary switch module with a circuit breaker for factory installation.

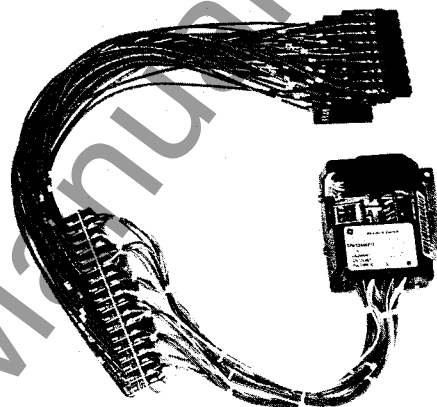

Figure 2. Auxiliary Switch Module with 8 switches for draw-out breakers.

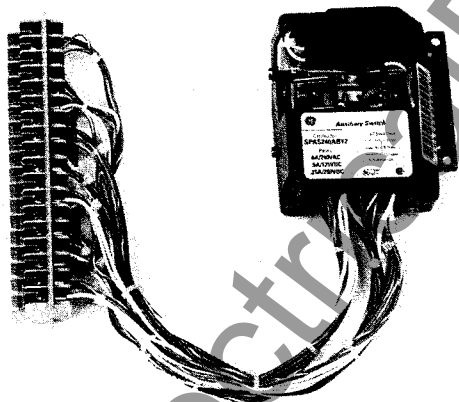

Figure 1. Auxiliary Switch Module with 12 switches for stationary breakers.

# Switches	240 Vac	600 Vac*
4	SPAS240AB4DR	SPAS600AB4DR
8	SPAS240AB8DR	SPAS600AB8DR
12	SPAS240AB12DR	—

* 600 Vac devices are not UL listed.

Table 2. Auxiliary Switch Module catalog numbers for draw-out breakers.

# Switches	240 Vac	600 Vac*
4	SPAS240AB4R	SPAS600AB4R
8	SPAS240AB8R	SPAS600AB8R
12	SPAS240AB12R	—

* 600 Vac devices are not UL listed.

Table 1. Auxiliary Switch Module catalog numbers for stationary breakers.

Operation

Each auxiliary switch is a single-pole double-throw element providing two outputs that can be used to indicate breaker main contact position. The A output is open or closed the same as the breaker, while the B output is the opposite to the breaker contacts. Figure 3 is a wiring diagram of each auxiliary switch.

The connections for the auxiliary switch outputs are found on the terminal block (for stationary breakers) or on the secondary disconnect terminal plug (for draw-out breakers) on the left side of the breaker and are listed in Table 3.

The auxiliary switch contacts lag the opening of the breaker contacts by 10 milliseconds. When the breaker is closing, the auxiliary switch contacts actuate 19 ms before the breaker contacts make.

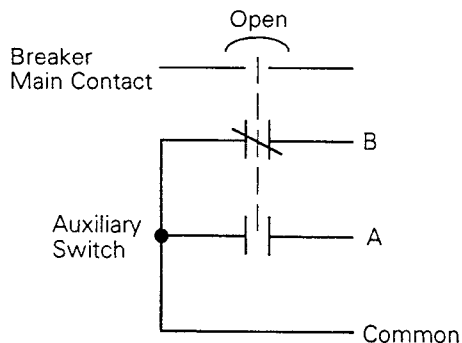

Figure 3. Auxiliary switch wiring diagram.

Terminal	Terminal
1 Auxiliary 12 A	19 Auxiliary 11 A
2 Auxiliary 12 B	20 Auxiliary 11 B
3 Auxiliary 12 common	21 Auxiliary 11 common
4 Auxiliary 10 A	22 Auxiliary 9 A
5 Auxiliary 10 B	23 Auxiliary 9 B
6 Auxiliary 10 common	24 Auxiliary 9 common
7 Auxiliary 8 A	25 Auxiliary 7 A
8 Auxiliary 8 B	26 Auxiliary 7 B
9 Auxiliary 8 common	27 Auxiliary 7 common
10 Auxiliary 6 A	28 Auxiliary 5 A
11 Auxiliary 6 B	29 Auxiliary 5 B
12 Auxiliary 6 common	30 Auxiliary 5 common
13 Auxiliary 4 A	31 Auxiliary 3 A
14 Auxiliary 4 B	32 Auxiliary 3 B
15 Auxiliary 4 common	33 Auxiliary 3 common
16 Auxiliary 2 A	34 Auxiliary 1 A
17 Auxiliary 2 B	35 Auxiliary 1 B
18 Auxiliary 2 common	36 Auxiliary 1 common

Table 3. Auxiliary switch positions on the terminal board (A block) or secondary disconnect plug on the left side of the breaker.

Installation

WARNING: Before installing any accessories, turn the breaker off, disconnect it from all voltage sources, and discharge the closing springs.

AVERTISSEMENT: Avant d'installer tout accessoire, mettre le disjoncteur en position OFF, le déconnecter de toute tension d'alimentation, et décharger les ressorts d'armement.

Install the Auxiliary Switch Module with the following procedure. Steps 12–15 apply only to installation in a draw-out breaker.

- Loosen the four #8-32 screws on the trim-plate assembly and remove the trim plate.
- Loosen the four #10-32 screws at the corner of the breaker cover. Remove the cover from the breaker face.
- Pull the trip unit locking lever out from the trip unit riser bracket, then lift the Trip Unit straight out of the breaker.



Figure 4. Removing the screws on the trip unit riser bracket.

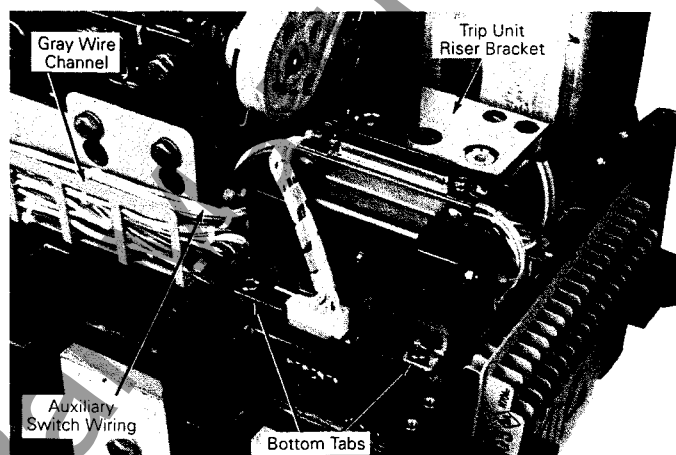

Figure 5. Auxiliary Switch Module installed under the trip unit plate.

- Remove the four Philips-head screws on the trip unit riser bracket, as illustrated in Figure 4. Keep the screws for installation of the Auxiliary Switch Module, but discard the bracket. A new bracket is included as part of the kit.
- Unplug the white connector for the CT wire harness, shown in Figure 4 in front of the riser bracket.
- Insert the Auxiliary Switch Module by resting the bottom tabs on the breaker and rotating the module under the trip unit plate, as shown in Figure 5. The switches click when they are inserted properly. Ensure that none of the wires are pinched between the Auxiliary Switch Module and the breaker mechanism.
- Reinstall the four #10-32 screws removed from the riser bracket, as shown in Figure 5, and tighten to 25 in-lb, beginning at the top.
- Reconnect the CT wire harness that was disconnected in step 5.**

WARNING: Failure to reconnect the CT harness will result in damage to the circuit breaker and loss of trip unit protection.

AVERTISSEMENT: Si les transformateurs d'intensité sont mal connectés, le disjoncteur perdra sa fonction de protection et sera endommagé.

9. Check the continuity of all switches with the breaker off.
10. Rotate the breaker torque shaft, located immediately above the Auxiliary Switch Module, 60–90° counterclockwise with a $\frac{7}{16}$ " socket wrench. The switches should change state with an audible click, and again when the shaft is allowed to return. This verifies proper installation of the module.
11. Remove the terminal block on the left side of the breaker, saving the screw for reuse.
12. Route the auxiliary switch wires through the gray-painted channel, as shown in Figures 5 and 6, using wire ties as needed to secure the wires. Ensure that the wires do not come into contact with any moving parts.
13. Attach the new terminal block on the left side of the breaker, using the screw removed in step 10.
14. (For installation in a stationary breaker, skip to step 16.) Slide the detent cam into the carriage side frame from the inside. Install one or two detent cam springs, as supplied, onto the inside of the carriage side frame and secure with two recessed pan-head #8-32, $\frac{3}{8}$ -inch screws and lock washers, as illustrated in Figure 7. Tighten the screws to 20 in-lb. The springs are bent and must be installed with the bend away from the steel frame to apply the minimum force against the detent cam.
15. The rear mounting guide rail block is mounted on the carriage side frame at the factory.
16. Slide the two mounting rods into the two holes in the secondary disconnect plug and then into the rear guide rail mounting block. Fasten the front guide rail mounting block to the side frame with two #8-32 flat-head screws, being sure to capture the two rails. Torque the screws to 20 in-lb. Route the secondary disconnect wires as shown in Figure 8 for small-frame (800–2000 A) breakers and in Figure 9 for large-frame (2500–4000 A) breakers.
17. The secondary disconnect should slide along the full length of the rails without stressing the wires. Position the plug toward the rear of the breaker. The detent cam will keep it there until the breaker is racked into the compartment. The force needed to release the detent should be a minimum of 20 pounds.
18. Pull the trip unit locking lever to the right. While holding the lever, carefully align the connector on the rear of the Trip Unit with the connector in the breaker. Press down on the Trip Unit, while holding it near the battery cover. When the Trip Unit is fully seated, slide the locking lever back to the left.
19. If the auxiliary switch module is rated at 600 volts, do the following:
 - Remove the UL label from the breaker top cover.
 - Apply the 600 V auxiliary switch rating label over the $1\frac{1}{2}$ " \times $7\frac{1}{2}$ " label on the left side of the breaker top cover so that it covers the existing switch ratings.

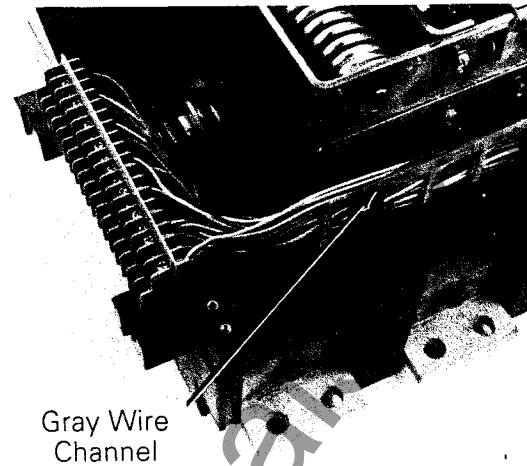

Figure 6. Terminal block connected to the left side of the breaker and wires properly arranged in the wire channel.

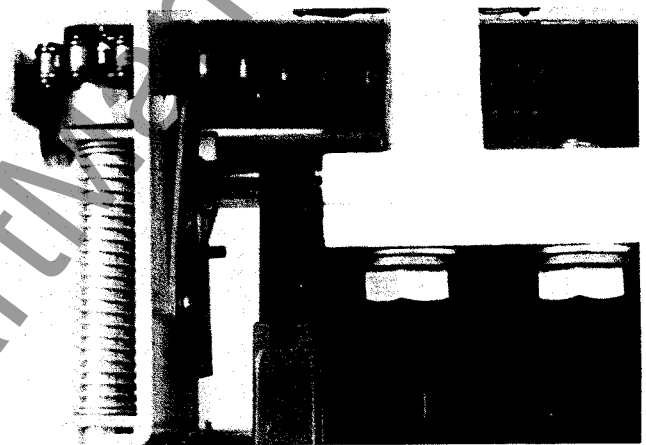

Figure 7. Installation of the detent cam on a draw-out breaker (offset screwdriver required).

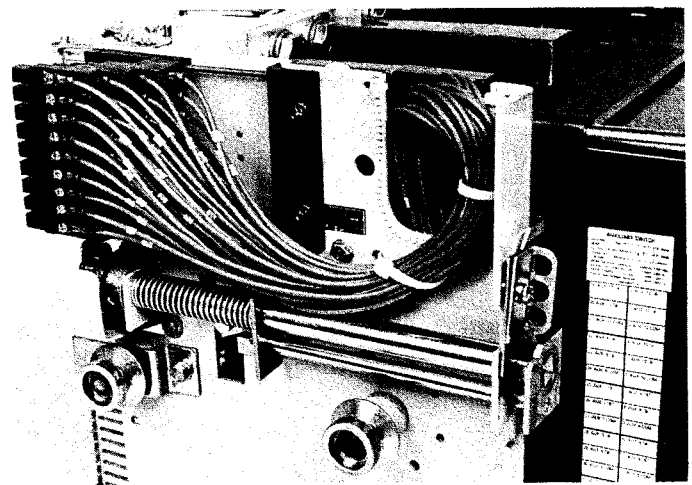

Figure 8. Routing of the secondary disconnect wires on a small-frame draw-out breaker and installing the secondary disconnect plug.

20. Reinstall the breaker top cover and tighten the four #10-32 screws to 15 in-lb. Ensure that the wires are not pinched beneath the edge of the breaker cover.
21. Replace the trim plate and tighten the four #8-32 screws to 20 in-lb.

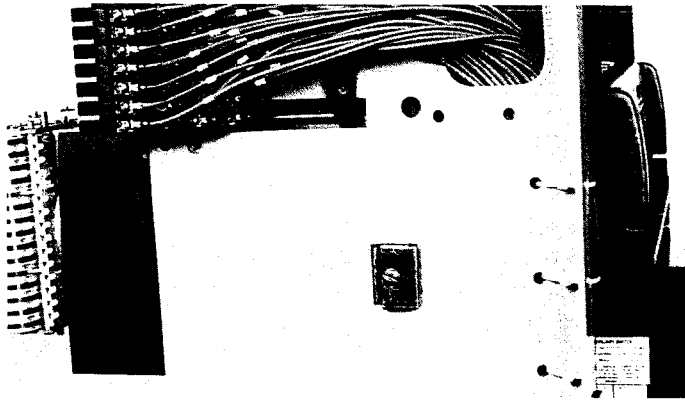

Figure 9. Routing of the secondary disconnect wires on a large-frame draw-out breaker and installing the secondary disconnect plug.

22. Bench test the proper operation of each switch with the Test Procedure.
23. Connect the switch accessory to the appropriate application, then follow the normal procedure to recharge the springs and turn the breaker on.

Test Procedure

Test each auxiliary switch in the newly installed module for proper operation with the following procedure:

1. With the breaker disconnected from all voltage sources and the main contacts open, test for continuity between the common and B terminals on the left terminal block if the module was installed in a stationary breaker. For installation in a draw-out breaker, test for continuity between the common and B terminals on the left secondary disconnect terminal plug. (Refer to Table 3 for the proper terminal positions.)
2. Verify that the common and A terminals show an open circuit.
3. Close the breaker, then verify continuity between the common and A terminals.
4. Verify that the common and B terminals show an open circuit.

Trouble-Shooting

The following guide is provided for trouble-shooting and isolating common problems. It does not cover every possible situation. Contact the ED&C Customer Support Center at 800-843-3742 if any problem is not resolved by these procedures.

Symptom	Possible Cause	Corrective Action
1. Switches do not change state when the breaker turns from off to on.	The four Philips-head mounting screws were not securely tightened.	Tighten all four screws.
2. The Trip Unit does not plug in.	The wrong Trip Unit is being used. The Trip Unit is not seated in the socket.	Remove the Trip Unit and insert the correct one. Reinstall the Trip Unit, pressing down firmly when the connector is aligned.
3. The main cover cannot be reinstalled.	The terminal block was not installed correctly.	Check the alignment of the terminal block and reinstall, if necessary.
4. The detent cam releases before the secondary disconnects are fully mated.	The detent cam or leaf springs were installed incorrectly.	Correct the detent cam and leaf spring positions. The spring's bend must be away from the steel side frame. Refer to the right side frame for the cam orientation. Check that the detent release force is at least 20 pounds, since the force needed to mate the secondary disconnects is 10–18 pounds.
5. The secondary disconnects unmate before resetting over the detent cam to the rear end stop.	The detent cam or leaf springs were installed incorrectly.	Same as Symptom 4. In addition, check that the reset force over the cam is 4 lb maximum and that the unmate force of the secondary disconnect is 8 lb minimum.

These instructions do not cover all details or variations in equipment nor do they provide for every possible contingency that may be met in connection with installation, operation, or maintenance. Should further information be desired or should particular problems arise that are not covered sufficiently for the purchaser's purposes, the matter should be referred to the GE Company.



GE Electrical Distribution & Control

General Electric Company
41 Woodford Ave., Plainville, CT 06062
© 1997 General Electric Company