

RENEWAL PARTS

TYPE AG-3, AG-4, AG-13, AND AG-13X AIR CIRCUIT BREAKERS

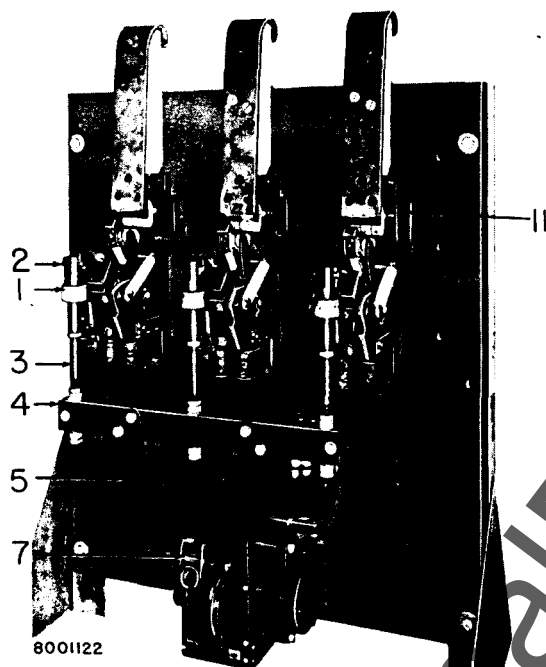

Fig. 1. Type AG-3 air circuit breaker

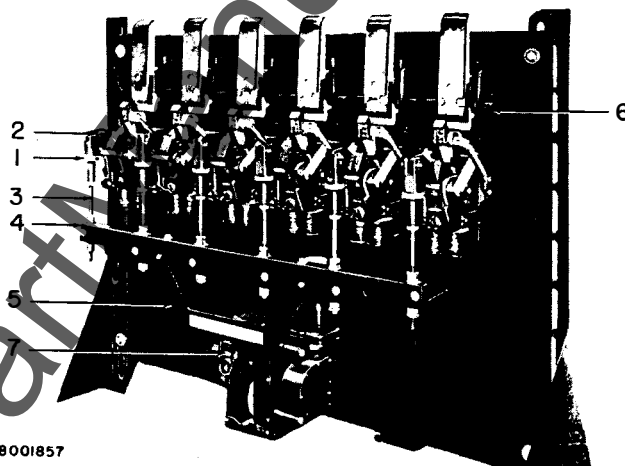

Fig. 1A. Type AG-4 air circuit breaker

ORDERING INSTRUCTIONS

1. Always specify the complete nameplate data of the breaker.
2. Specify the quantity, catalog number (if listed), reference number (if listed), description, and this bulletin number.
3. Standard hardware such as screws, bolts, nuts, washers, etc., is not listed in this bulletin. Such items should be purchased locally.
4. For prices, refer to the nearest office of the General Electric Company.

When ordering renewal parts, give quantity, catalog number, description of each item required, and complete nameplate reading.

GENERAL  ELECTRIC

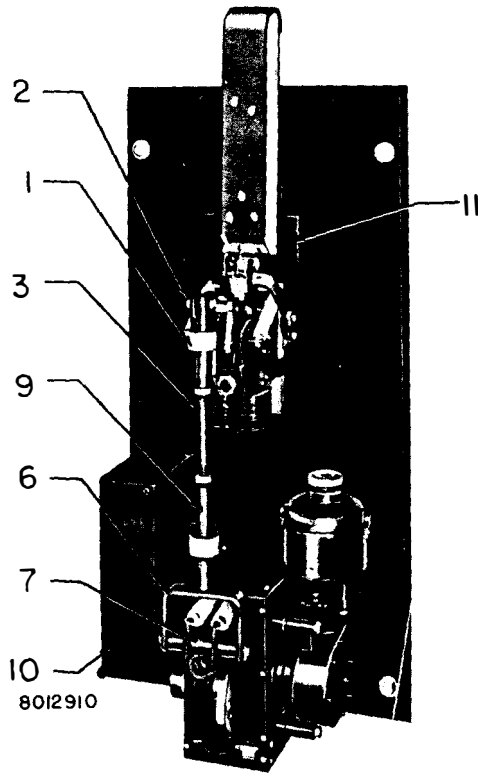

Fig. 1B. Type AG-13 air circuit breaker, 2000 amp, 850 volt

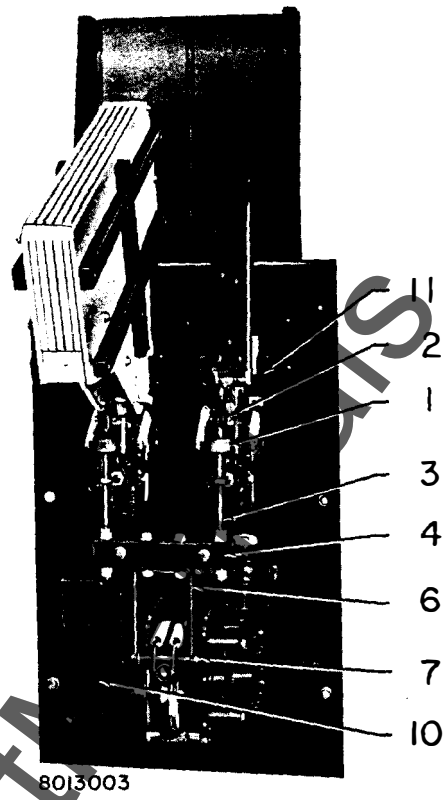

Fig. 1C. Type AG-13X air circuit breaker, 4000 amp, 850 volt

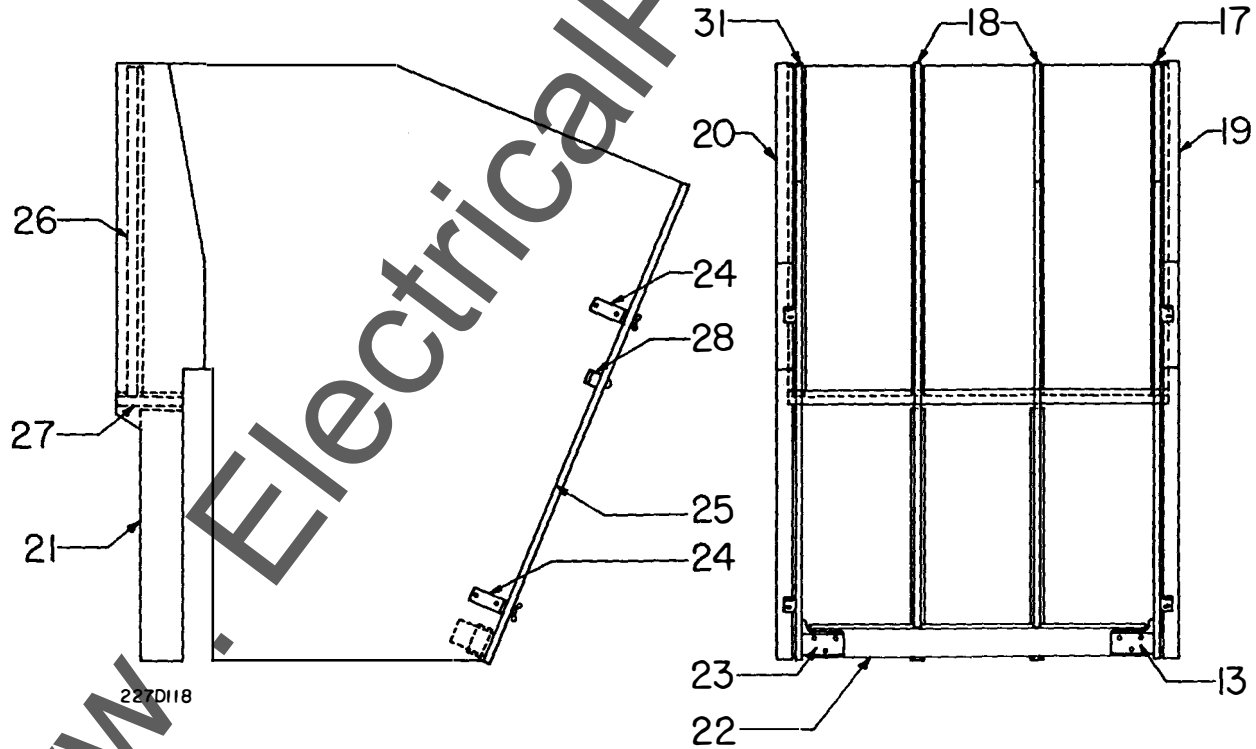

Fig. 2. Barrier assembly for Type AG-3 breaker

AIR CIRCUIT BREAKERS

GEF-3834A

Fig. No.	Ref. No.	No. Per Breaker				Catalog No.	Description
		AG-3	AG-4	AG-13	AG-13X		
1, 1A, 1B, 1C	1	3	6	1	2	6372202P1	Insulated coupling
1, 1A, 1B, 1C	2	3	6	1	2	6076405P211	Pin
1, 1C	3	3			2	6244735P2	Connecting rod
1A	3		6			6244735P1	Connecting rod
1B	3			1		6244735P3	Connecting rod
1	4	1				6317160P1	Cross bar
1A	4		1			6317267P1	Cross bar
1C	4				1	9921635P1	Cross bar
1	5	1				6329411G1	Connecting frame
1A	5		1			6329351G1	Connecting frame
1B	6			1		6203808G1	Connecting yoke
1C	6				1	9921636P1	Connecting yoke
1, 1A, 1B, 1C	7	1	1	1	1	6076405P263	Pin
1B	9			1		6203807P1	Connecting link
1B, 1C	10	1	1	1	1	12HKA11X4	Relay (220 to 250-volt, 60 cycles d-c)
1B, 1C	10	1	1	1	1	12HKA11X3	Relay (110 to 125-volt, 60 cycles d-c)
1B, 1C	10	1	1	1	1	12KHA11X6	Relay (208 to 260-volt, 60 cycles a-c)
	*	1	1	1	1	3616747G1	Operating handle
2	15	1				176L152G1	Barrier assembly
2	15			1		176L152G2	Barrier assembly
2	15				1	6454182G1	Barrier assembly
2	16	1		1	1	6329408P1	Barrier
2	17	1		1	1	6329408P2	Barrier
2	18	2			1	6329408P3	Barrier
2	19	1			1	6329408P4	Support
2	19			1		6414603P2	Support
2	20			1		6414603P1	Support
2	20	1			1	6329408P5	Support
2	21	2				6329408P7	Brace
2	22	1				6317155P3	Cross tie
2	22			1		6203805P1	Cross tie
2	22				1	6454182P12	Cross tie
2	23	2			2	6302978P1	Bracket
2	24	4		4	4	6175203G1	Bracket
2	25	1				6372335G1	Front cover
2	25			1		6203802G1	Front cover
2	25				1	6454182P26	Front cover
2	26	1				6317155P1	Rear barrier
2	26			1		6414602P1	Rear barrier
2	26				1	6454182P7	Rear barrier
2	27	1				6317155P2	Rear support
2	27			1		6414602P2	Rear support
2	27				1	6454182P8	Rear support
2	28				1	6454182P17	Brace
2	*	6		6	4	393A993P1	Expansion screw anchor (fastens barrier to base)

* Not illustrated.

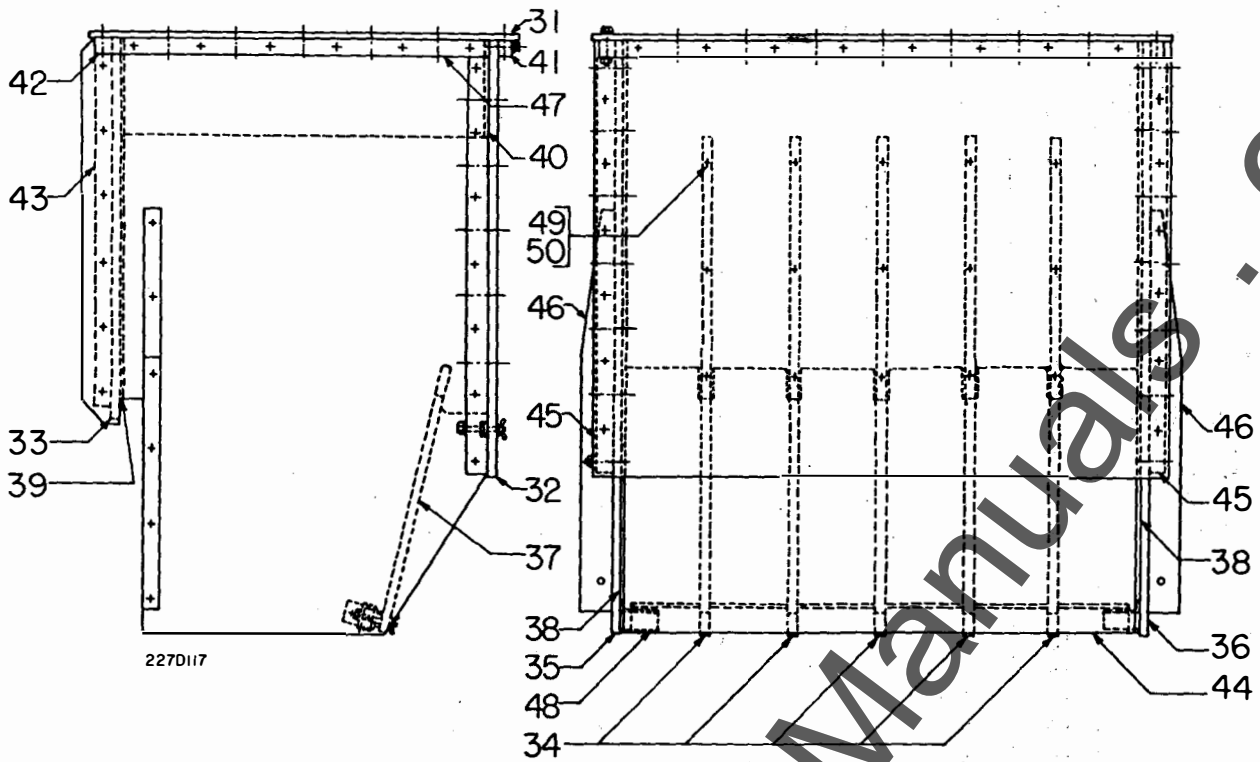

Fig. 3. Barrier assembly for Type AG-4 breaker

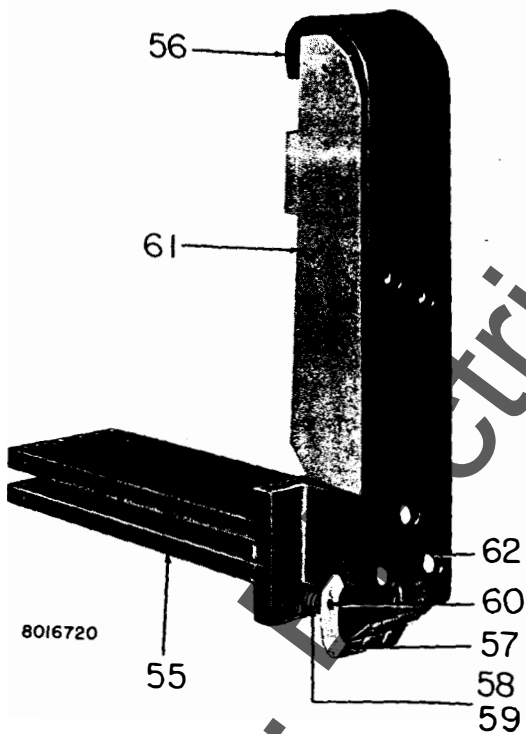

Fig. 4. Upper stud

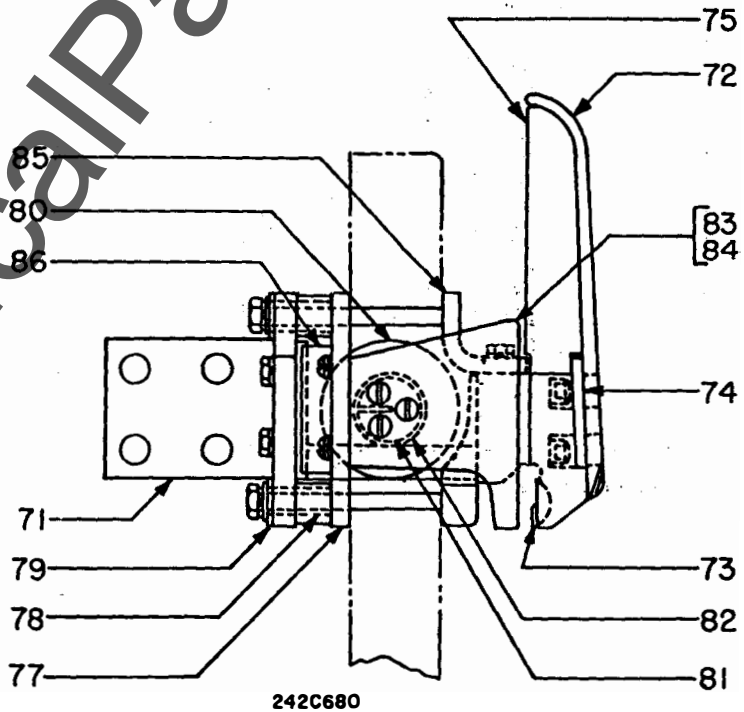

Fig. 5. Blowout coil for Type AG-4 breaker

AIR CIRCUIT BREAKERS

GEF-3834A

Fig. No.	Ref. No.	No. Per Breaker				Catalog No.	Description
		AG-3	AG-4	AG-13	AG-13X		
3	51		1			6357035G1	Barrier assembly
3	31		1			6357032P1	Top
3	32		1			6357032P2	Barrier (front)
3	33		1			6357032P3	Barrier (rear)
3	34		5			6357032P4	Barrier (center)
3	35		1			6357032P5	Barrier (L. side)
3	36		1			6357032P6	Barrier (R. side)
3	37		1			6357032P7	Barrier (lower front)
3	38		2			6357032P8	Insulation (side)
3	39		1			6357032P9	Insulation (rear)
3	40		1			6357032P10	Insulation (front)
3	41		1			6357032P11	Support
3	42		1			6357032P12	Support
3	43		2			6357032P13	Support
3	44		1			6357032P14	Support
3	45		2			6357032P15	Support
3	46		2			6357032P16	Support
3	47		2			6357032P17	Support
3	48		2			6302978P1	Bracket
3	49		51			6246971P1	Retainer
3	50		51			6246970P1	Retainer plug
4	55	3		1		6317268G1	Stud (horizontal)
4	55	3				6423662G1	Stud (2160 amp only)
4	55			1		6317259G1	Stud (vertical)
4	55			1		6414386G1	Stud (2500 amp)
4	55				2	6414386G2	Stud (horizontal)
4	55				2	6414731G1	Stud (vertical)
4	56	3		1	2	393A635G2	Arc runner and secondary contact
4	56	3		1	2	393A635G4	Arc runner and secondary contact for AG-3-1, AG-3-2, AG-13-1, AG-13-2, AG-13X-1, or AG-13X-2
4	57	9	18	3	6	6302989G1	Primary contact
4	58	9	18	3	6	6172501G1	Primary contact spring
4	59	9	18	3	6	6244723P1	Insulator bushing
4	60	9	18	3	6	6302989P4	Pin
1, 1B, 1C	11	3		1	2	6303538P2	Barrier block
4	61	3		1	2	6317156P1	Filler block
4	62	3		1	2	6303882P2	Filler plate
	*	3		1	2	6317156P2	Side filler (fastens to left side of Ref. 61)
	*	3		1	2	6317156P3	Side filler (fastens to right side of Ref. 61)
	*			6		371A281P1	Adapter bar (2000 amp only, used to convert breaker to D.O.)
5	71		6			6317488G1	Stud (vertical)
5	72		6			393A635G3	Arc runner and secondary contact
5	73		6			6246850P1	Stop
5	74		6			6303882P2	Filler plate
5	75		6			6372667P2	Filler block
1A	6		6			6303538P3	Barrier block
5	77		6			6372672P1	Insulation
5	78		18			6372670P1	Insulation
5	79		18			6246969P1	Spacer
5	80		6			6317489G1	Blowout coil
5	81		6			6372668P1	Core
5	82		6			6372670P2	Insulation
5	83		6			6372669P1	Plate (L. side)
5	84		6			6372669P2	Plate (R. side)
5	85		3			6246962P1	Support
5	86		12			6246983P1	Insulation block

*Not illustrated.

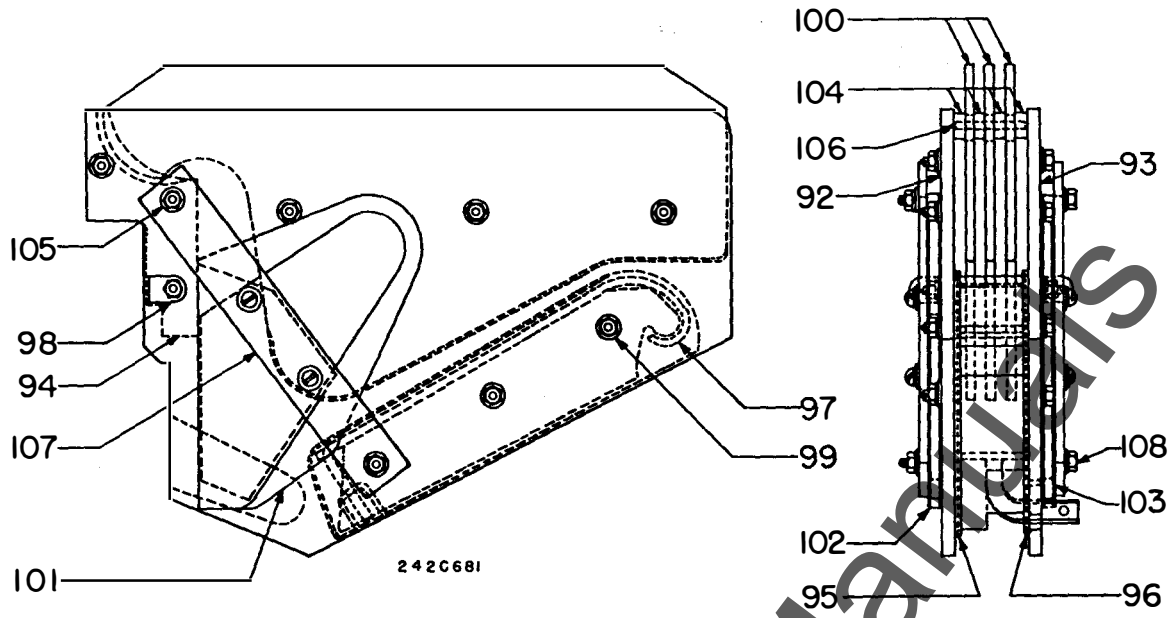

Fig. 6. Arc chute for Type AG-4 breaker

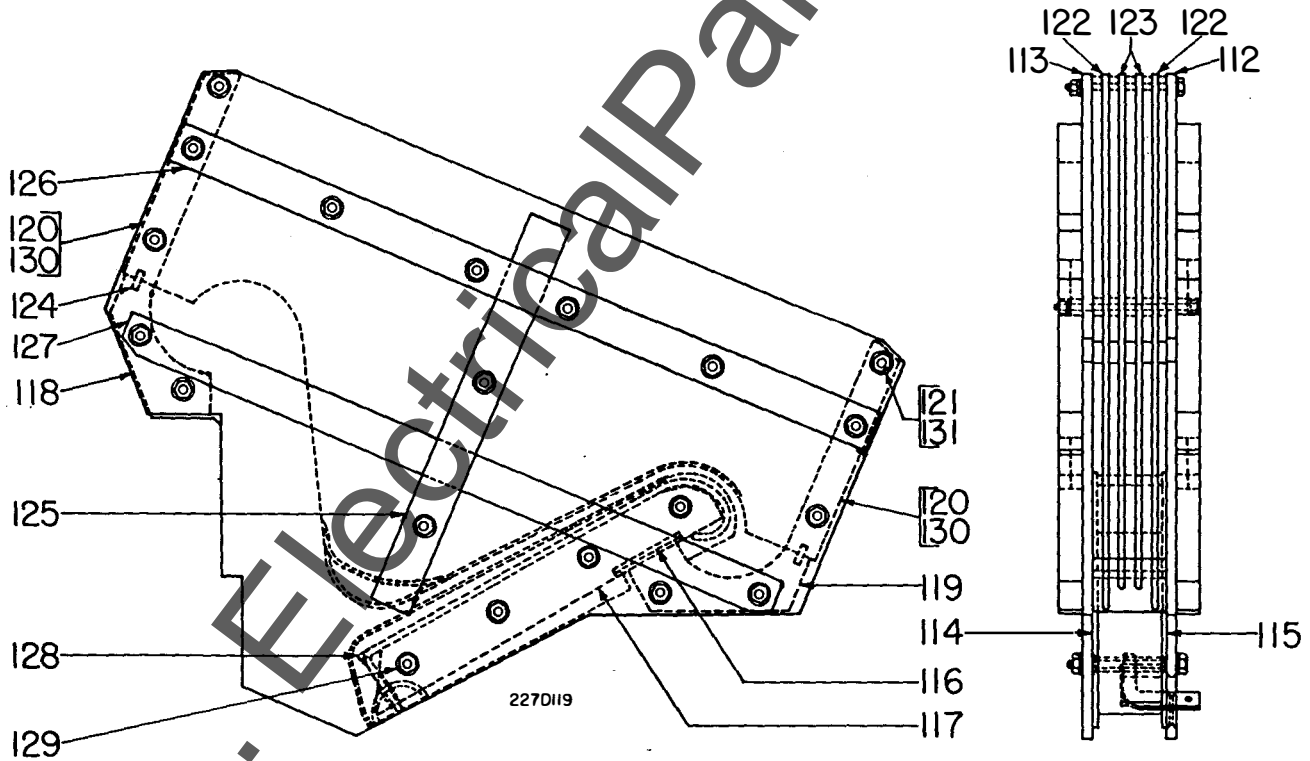

Fig. 7. Arc chute for Type AG-3 breaker

AIR CIRCUIT BREAKERS

GEF-3834A

Fig. No.	Ref. No.	No. Per Breaker				Catalog No.	Description
		AG-3	AG-4	AG-13	AG-13X		
6	91		6			6329556G1	Arc chute, complete
6	92		6			6329553P1	Side
6	93		6			6329553P2	Side
6	94		6			6329553P3	Spacer block
6	95		6			6329340P3	Insulator
6	96		6			6329340P4	Insulator
6	97		6			6372687G1	Arc runner
6	98		12			6244731P1	Mounting angle
6	99		18			6244730P1	Insulator tube
6	100		18			6317500P1	Splitter
6	101		12			6372671P1	Plate
6	102		6			6372673P1	Insulation
6	103		6			6372673P2	Insulation
6	104		144			6246811P1	Spacer
6	105		24			6246963P3	Spacer
6	106		18			6248738P1	Pin
6	107		12			6246964P1	Support
6	108		12			6208489P33	Screw
7	111	3		1	2	6135096G1	Arc chute, complete
7	112	3		1	2	6329400P1	Side
7	113	3		1	2	6329400P2	Side
7	114	3		1	2	6329449P4	Insulation
7	115	3		1	2	6329449P5	Insulation
7	116	3		1	2	6329449P7	Insulation
7	117	3		1	2	6329400P3	Arc runner support
7	118	3		1	2	6329400P7	Spacer
7	119	3		1	2	6329400P8	Spacer
7	120	30		10	20	6329449P3	Spacer
7	121	90		30	60	6246811P1	Spacer
7	122	6		2	4	6329449P1	Splitter
7	123	6		2	4	6329449P2	Splitter
7	124	6		2	4	6329449P6	Seal
7	125	6		2	4	6329400P4	Support
7	126	6		2	4	6329400P5	Support
7	127	6		2	4	6329400P6	Support
7	128	3		1	2	6329401G1	Arc runner
7	129	12		4	8	6246812P1	Bushing
7	130	18		6	12	6329449P8	Shim
7	131	54		18	36	6246811P2	Spacer

www.ElectricalManuals.com

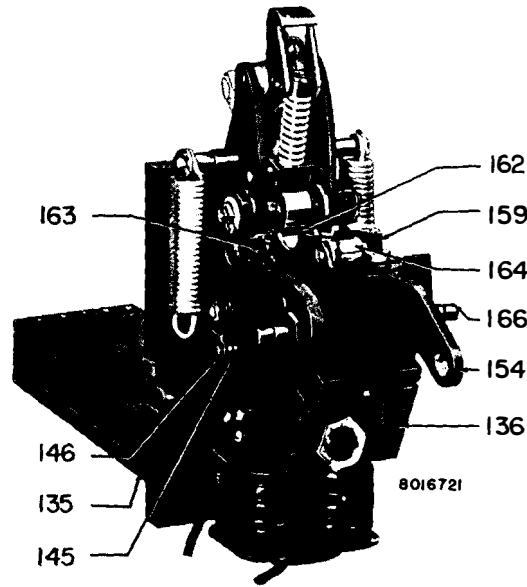

Fig. 8. Pole unit mechanism

Fig. 8A. Operating mechanism

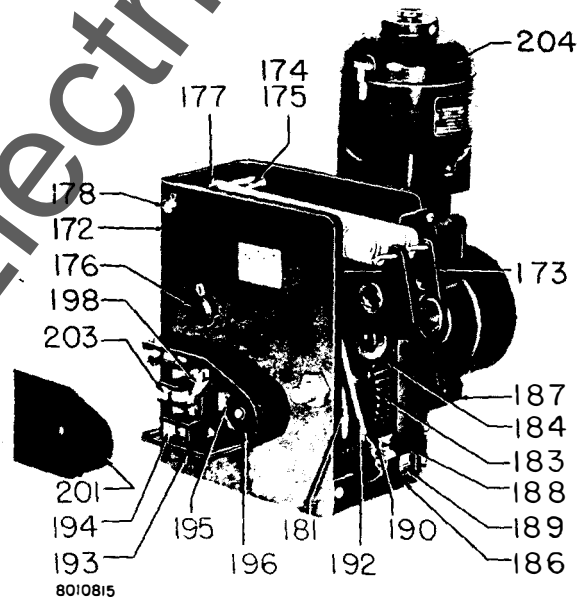

Fig. 9. Type MB-3 motor operated mechanism

www.ElectricalPartManuals.com

AIR CIRCUIT BREAKERS

GEF-3834A

Fig. No.	Ref. No.	No. Per Breaker				Catalog No.	Description
		AG-3	AG-4	AG-13	AG-13X		
8	135	3		1		6317161G1	Stud (1600 amp, AG-3 or 2000 amp. AG-13 with 7 in. stud)
8	135	3				6423663G1	Stud (2160-amp)
8	135			1		6414388G1	Stud (2500-amp stationary)
8	135		6			6212213P1	Stud
8	135			1		6414702G2	Stud (2000-amp)
8	135				2	6414733G1	Stud
8	136	3	6	1	2	6357019P1	Frame
8	136	3				6357019P2	Frame (1600-amp)
8A	137	3	6	1	2	6057403P1	Spring post
	*	3	6	1	2	6246092P1	Pin support (for Ref. 36)
	*	9	18	3	6	6275569P2	Shim
8A	140	3	6	1	2	6201333G1	Prop latch (Cam 6201352P1, Ref. 147 must also be ordered)
8A	141	3	6	1	2	6241384P1	Link (left)
8A	142	3	6	1	2	6302968G1	Link (right)
8A	143	3	6	1	2	6246090P1	Pin
	*	3	6	1	2	6241823P1	Spring post (Fastened on left side of Ref. 36 to hold Ref. 152)
8	145	6	12	2	4	6241448P1	Sleeve
8	146	6	12	2	4	6241829P1	Retainer
8A	147	3	6	1	2	6201352P1	Cam (Latch 6201333G1, Ref. 140 must also be ordered)
8A	148	3	6	1	2	6372345P1	Spring
8A	149	3	6	1	2	6241454P1	Pin
	*	6	12	2	4	6002721P168	Spacer (right side of Ref. 149)
8A	151	3	6	1	2	6172526	Spring
8A	152	6	12	2	4	6172527	Spring
8A	153	3	6	1	2	6201334G1	Closing lever
8	154	3	6	1	2	6317264G1	Operating lever
	*	6	12	2	4	6241383P1	Bushing (On Ref. 158, used for Ref. 154)
	*	3	6	1	2	6244721P1	Bushing on left side (On Ref. 158 to space Ref. 154 and 153)
	*	3	6	1	2	6244722P1	Bushing on right side (On Ref. 158 to space Ref. 154 and 153)
8A	158	3	6	1	2	6241498P1	Pin
8	159	3	6	1	2	6241850P1	Adjusting screw
8A	160	6	12	2	4	6241385P1	Link
	*	3	6	1	2	6002721P167	Spacer (left side of Ref. 149)
8	162	3	6	1	2	6244762P2	Roller
8	163	3	6	1	2	6244763	Pin
8	164	3	6	1	2	6244760P1	Pin
8A	165	6	12	2	4	6241382P1	Retaining screw
8	166	6	12	2	4	6241458P1	Spring post
	*	3	6	1	2	6414381G1	Pawl assembly (left-hand mounting)
	*	3	6	1	2	6414381G2	Pawl assembly (right-hand mounting)
	*	3				6192382P5	Counter
	*	3	6			6370725P1	Counter
	*	3				6404899P1	Support (for counter)
	*	3	6			6442689P1	Support (for counter)
	*	3	6			6172529	Spring (for counter)
9	171	1	1	1	1	6155321G3	Motor mechanism (complete)
9	172	1	1	1	1	6217582G1	Frame
9	173	1	1	1	1	6317265G1	Operating lever
9	174	1	1	1	1	6176110P105	Spacer
9	175	2	2	2	2	174V560P2	Shim
9	176	1	1	1	1	6072409P256	Pin
9	177	2	2	2	2	6172507	Spring
9	178	1	1	1	1	6076405P264	Pin
	*	1	1	1	1	6241480	Roller (for Ref. 173)
	*	1	1	1	1	6076406P221	Pin (fastens roller to Ref. 173)
9	181	1	1	1	1	6212222G1	Cam
	*	1	1	1	1	6241501	Cam shaft

*No illustrated.

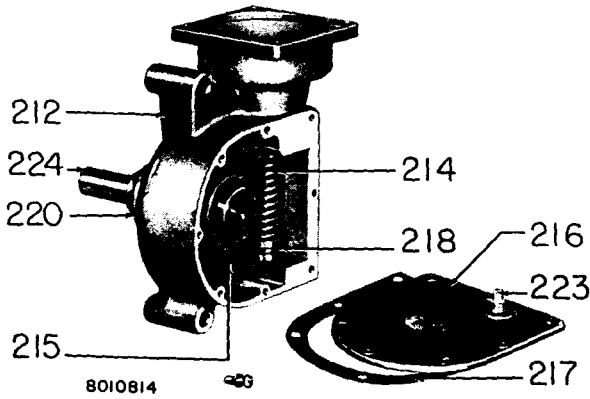

Fig. 10. Gear reducer

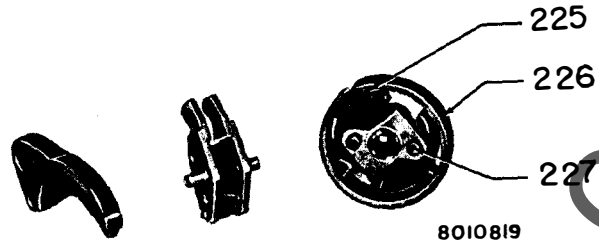

Fig. 10A. Torque brake

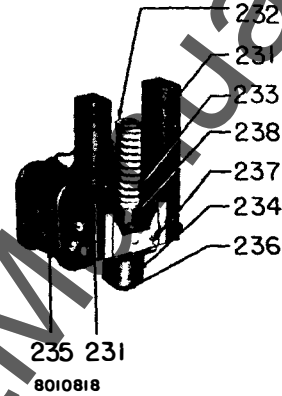

Fig. 11. Directional trip device

Fig. No.	Ref. No.	No. Per Breaker				Catalog No.	Description
		AG-3	AG-4	AG-13	AG-13X		
9	183	1	1	1	1	6414280P1	Gear
9	184	1	1	1	1	6414280P3	Gear
	*	1	1	1	1	6201402P1	Cover (top)
9	186	1	1	1	1	6201402P2	Cover
9	187	3	3	3	3	6241487	Spacer
9	188	1	1	1	1	6201402P3	Cover
9	189	1	1	1	1	6370725P1	Counter
9	190	1	1	1	1	6241484	Counter support
	*	1	1	1	1	6057403	Spring post (for Ref. 192)
9	192	1	1	1	1	6172508	Spring
9	193	1	1	1	1	6228280G1	Motor cut-off switch
9	194	1	1	1	1	6228280G2	Base and contacts
9	195	1	1	1	1	6275134P1	Shaft
9	196	1	1	1	1	6246984	Cam
	*	1	1	1	1	6246040P1	Sleeve (for Ref. 195)
9	198	1	1	1	1	6275131P1	Contact (movable)
	*	1	1	1	1	6172545	Pressure spring (for Ref. 198)
	*	1	1	1	1	6172544	Opening spring (for Ref. 198)
9	201	1	1	1	1	6275132P1	Cover
	*	1	1	1	1	6246041P1	Cover (back)
9	203	5	5	5	5	1487612	Binding screw
9	204	1	1	1	1	-----	Motor, Model No. 5PA66MA3
9	204	1	1	1	1	-----	Motor, Model No. 5PA66MA4
10	211	1	1	1	1	6052820G7	Gear reducer
10	212	1	1	1	1	6125001G1	Gear box
	*	1	1	1	1	238C110P1	Worm and wheel

*No illustrated.

AIR CIRCUIT BREAKERS

GEF-3834A

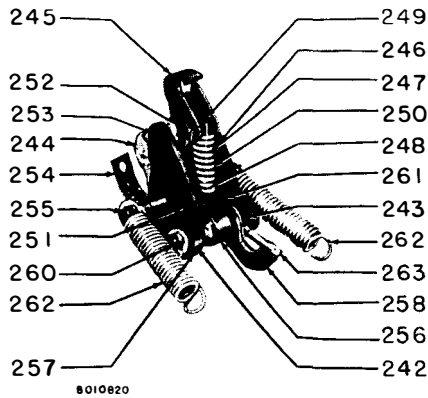

Fig. 12. Movable contact.

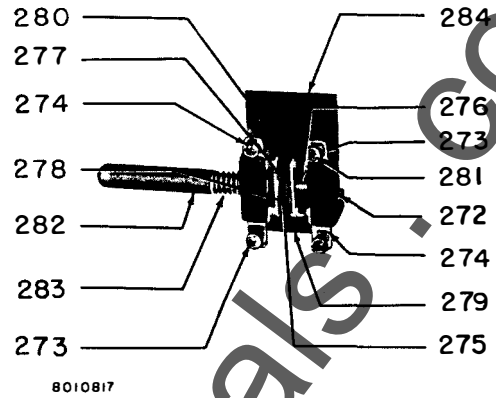

Fig. 13. Push type auxiliary switch

Fig. No.	Ref. No.	No. Per Breaker				Catalog No.	Description
		AG-3	AG-4	AG-13	AG-13X		
10	214	1	1	1	1	238C110P2	Worm
10	215	1	1	1	1	238C110P3	Wheel
10	216	1	1	1	1	6071666P1	Cover
10	217	1	1	1	1	6059911	Gasket
10	218	1	1	1	1	393A796P5	Thrust bearing, #917C
	*	1	1	1	1	6057151	Retainer (for Ref. 214)
10	220	1	1	1	1	6058421	Cup
	*	1	1	1	1	-----	Pennzoil 400 sec oil
	*	1	1	1	1	N3400P606	Key (for Ref. 224)
10	223	1	1	1	1	6270992P12	Pipe plug, 1/8 in., sq. hd.
10	224	1	1	1	1	6241485	Gear shaft
10A	225	1	1	1	1	6115569G2	Brake shoes
10A	226	1	1	1	1	6175451P1	Brake drum
10A	227	1	1	1	1	6175449G2	Impeller
11	231	6	12	2	4	6201365G1	Magnet
11	232	3	6	1	2	6241466P1	Collar
11	233	3	6	1	2	6172505	Spring
11	234	3	6	1	2	6303305G1	Armature
11	235	3	6	1	2	0367A0263G5	Potential Coil (125-volt d-c)
11	235	3	6	1	2	0367A0263G6	Potential Coil (250-volt d-c)
11	236	3	6	1	2	6242691P1	Cap
11	237	3	6	1	2	6217571G1	Magnet yoke
11	238	3	6	1	2	6303301P1	Guide rod
12	241	3	6	1	2	176L152G3	Contact assembly
12	242	6	12	2	4	6241443P2	Buffer
12	243	6	12	2	4	6007608P3	Spacer
12	244	3	6	1	2	6317256G1	Main contact, lever
12	245	3	6	1	2	6302977G1	Arcing contact
12	246	6	12	2	4	6302975P1	Contact carrier
12	247	3	6	1	2	6244729P1	Spring guide
12	248	3	6	1	2	6244732P1	Spring guide
12	249	3	6	1	2	6244728P1	Spring retainer
12	250	3	6	1	2	6071980	Spring
12	251	3	6	1	2	6244724P1	Pin
12	252	3	6	1	2	6076401P208	Pin
12	253	3	6	1	2	6244727P1	Pin
12	254	3	6	1	2	6302982G1	Flexible braid
12	255	3	6	1	2	6241447P1	Pin
12	256	3	6	1	2	6241389P1	Roller
12	257	6	12	2	4	6241443P2	Buffer
12	258	3	6	1	2	6303534P1	Hook latch
	*	3	6	1	2	6244428P1	Screw (fastens Ref. 254 to Ref. 244)
12	260	3	6	1	2	6241825P1	Pin

* Not illustrated.

AIR CIRCUIT BREAKERS

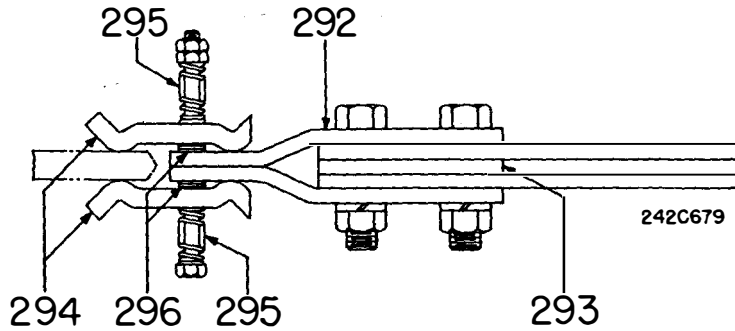

Fig. 14. Disconnect mechanism

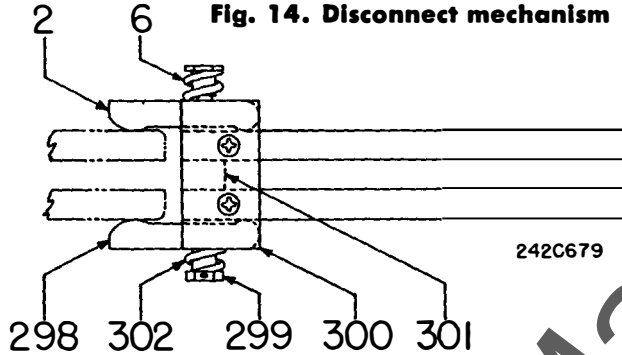

Fig. 14A. Disconnect mechanism for Type AG-3 breaker, 2160 amp

Fig. No.	Ref. No.	No. Per Breaker				Catalog No.	Description
		AG-3	AG-4	AG-13	AG-13X		
12	261	6	12	2	4	6244750P1	Spacer
12	262	6	12	2	4	6172512	Opening spring
12	263	3	6	1	2	6172599	Spring
13	271	3		1	2	6155357G2	Aux. switch (complete)
13	271		6			6155357G3	Aux. switch (complete)
13	272	3	6	1	2	542A989G1	Contact base
13	273	6	12	2	4	3845725G1	Contact bracket
13	274	6	12	2	4	3845725G2	Contact bracket
13	275	3	6	1	2	2480067	Insulation
13	276	3	6	1	2	2480066	Guide
13	277	3	6	1	2	6202672	Spring
13	278	6	12	2	4	3805658G1	Contact strip
13	279	3		1	2	6246038P1	Bracket
13	279		6			6246977P1	Bracket
13	280	3	6	1	2	6248741P1	Insulation
13	281	12	24	4	8	1487612	Binding screw
13	282	3	6	1	2	6241509P1	Plunger for 1 1/2 in. base
13	282	3	6	1	2	6241509P2	Plunger for 2 in. base
13	282	3	6	1	2	6241509P3	Plunger for 3 in. base
13	283	3	6	1	2	6202671	Spring
13	284		6			6246978P1	Barrier
14	291	Δ3		1		6317164G1	Disconnects (complete)
14	292	Δ12		4		6372537P1	Adapter
14	293	Δ6		2		6246828P1	Spacer
14	294	Δ48		16		6372339P1	Contact finger
14	295	Δ48		16		6175730	Spring
14	296	Δ96		32		6007608P8	Shim
14A	297	#6				6414713G1	Disconnects (complete)
14A	298	#72				6146948	Finger
14A	299	#36				6146960	Nut
14A	300	#12				6414713P7	End plate
14A	301	#6				6414713P8	Spacer
14A	302	#72				6176882	Spring

Δ Used for 1600 Amp. AG-3

Used for 2160 Amp. AG-3 only.

SWITCHGEAR DEPARTMENT, GENERAL ELECTRIC COMPANY, PHILADELPHIA, PA.