

Section 8 - Circuit Breaker Automatic Tripping System

8.0 GENERAL

The circuit breaker is tripped on overload and short circuit conditions by combined action of three components:

1. The sensors which determine the current level.
2. The Amptector solid-state trip unit which provides a tripping signal when pre-determined current levels are reached.
3. The Actuator which actually trips the circuit breaker.

Schematically this may be represented as shown in Figure 59. This provides a very flexible system covering a wide range of tripping characteristics. Not only is the

Amptector trip unit adjustable but the sensors are available over a wide range of current ratings.

The automatic overload and short circuit tripping characteristics for a specific breaker rating, as determined by the sensor rating, are determined by the settings of the Amptector solid-state trip unit. This unit also supplies a pulse of tripping current to the actuator. Thus all tripping functions are performed by secondary control circuitry, with no mechanical or direct magnetic action between the primary current and the mechanical tripping parts of the breaker.

The Amptector solid-state trip units are available in two basic versions; the Amptector II-A and the Amptector I-A.

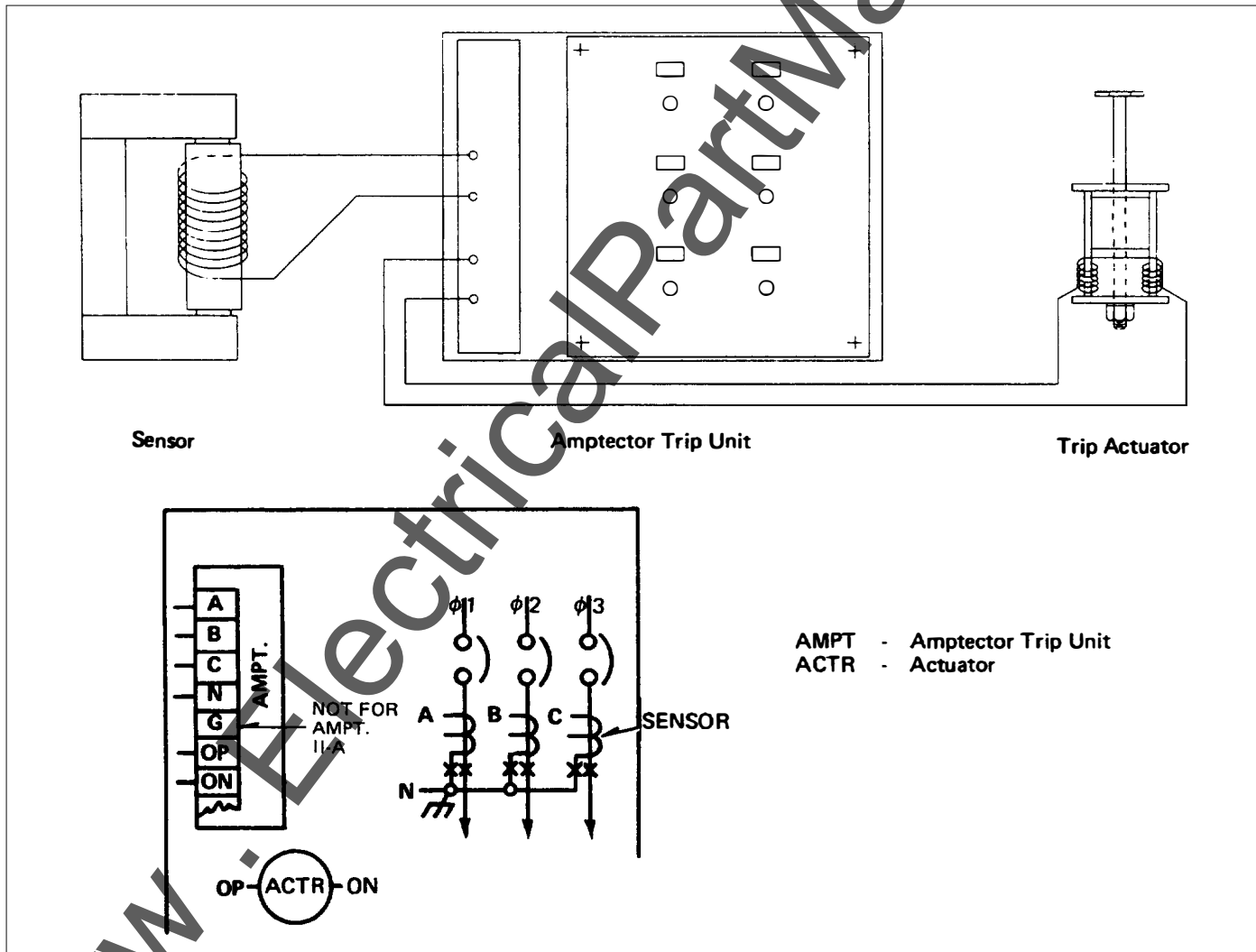

Fig. 59 Schematic Illustration of Tripping System

8.1 THE AMPTECTOR II-A TRIP UNIT

Improvements have been made to the Cutler-Hammer Amptector and the standard model is now Amptector II-A. Wiring and terminal changes were made to provide method of testing with a tester. Refer to Section 8.7.6 for testing with Amptector Test Kit.

Another change was to modify the long delay curve to nearly an I^2T function. The revised curve shows this change. See Curve No. 1.

The Amptector II-A is standard equipment on all DS and DSL circuit breakers. It provides approximately equivalent functions as the electro-mechanical trip devices provided on some circuit breakers but with the superior operating capability of solid-state devices. The Amptector I-A is an optional (extra cost) tripping system which can be provided when ground fault protection or trip indicators are required. Both trip units have the same reliability and repeatability inherent in solid-state design.

As shown in Figure 5 the Amptector trip unit is at the top front of the breaker. Figure 60 shows a close-up of the front of the Amptector II-A trip unit. There can be a total of five adjustable controls, with screwdriver adjustment. These are for setting the following characteristics:

1. Long-delay current pick-up.

2. Long-delay time.
3. Short-delay current pick-up.
4. Short-delay time.
5. Instantaneous current pick-up.

Note: The term "pick-up" as used here means the rms value of current at which the Amptector trip unit timing function begins or instantaneous tripping is initiated.

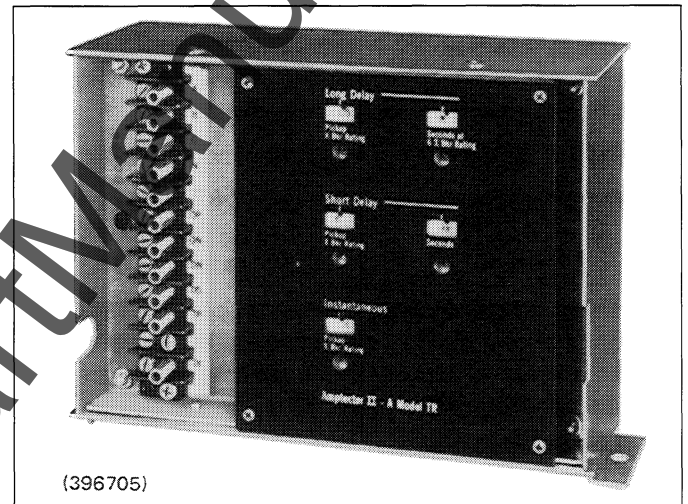
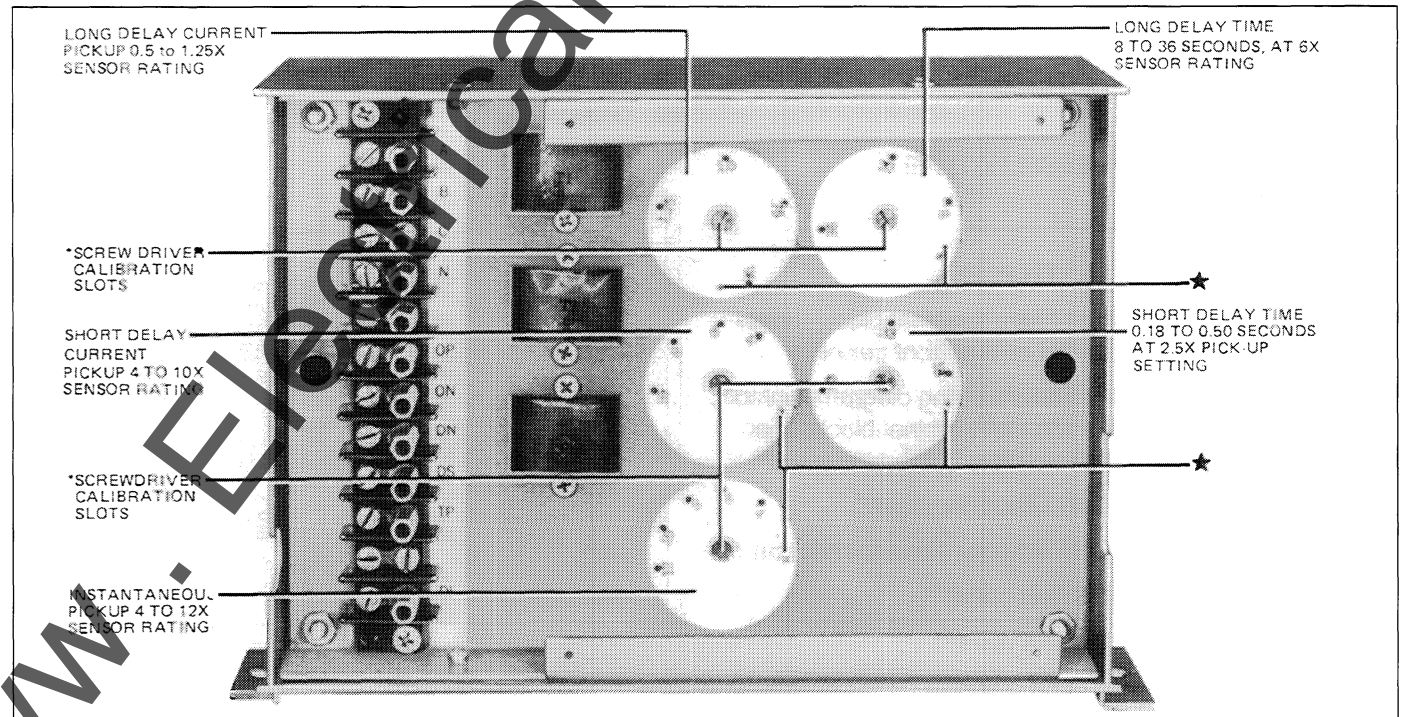

Fig. 60 Standard Amptector II-A Solid-State Trip Unit



See Section 8.4 of Text for Explanation

Fig. 61 Amptector II-A Trip Unit with Front Cover

Removed (396704)

Figure 61 is the Amptector II-A trip unit with front cover removed, showing all of the calibration marks on the dials. The ranges of current settings in multiples of sensor rating and time delay are as follows:

1. Long-delay pick-up .5 to 1.25 X sensor rating
2. Long-delay 8 to 36 seconds, at 6 X sensor rating

Over these ranges tripping will always occur within the time band shown on Curve No. 1, page 59. The bottom of the band is called the resettable delay. If the overload subsides in less than the resettable delay time, resetting of the trip unit will occur within a few cycles after the load drops to less than 90% of the pick-up setting.

3. Short-delay pick-up 4 to 10 X sensor rating
4. Short delay .18 seconds to .50 seconds or 11 to 30 cycles at 60 Hz, at 2.5 X pick-up setting.

Over these ranges tripping will always occur within the time band shown on Curve No. 1, page 59. Although the time adjustment is continuous, three time bands are calibrated as shown on the curve.

5. Instantaneous Pick-up 4 to 12 X sensor rating

Three different combinations of trip elements are provided. Those combinations with the corresponding Amptector II-A model designations as follows:

1. Long Delay
Instantaneous DU (DUAL)
2. Long Delay
Short Delay SE (SELECTIVE)
3. Long Delay
Short Delay
Instantaneous TR (TRIPLE)

Each Amptector II-A trip unit has a terminal block accessible on the front of the circuit breaker front panel.

Figure 59 shows a typical standard wiring diagram, which includes the Amptector II-A trip unit terminal block. The following table explains the markings of the terminals:

- | | |
|---------------------|------------------------------------|
| A Sensor phase A | ON Output negative* |
| B Sensor phase B | DN Test point (internal neutral)** |
| C Sensor phase C | DS Test point** |
| N Sensor neutral | TP Test point** |
| OP Output positive* | DI Test point** |

*To Actuator Coil. THIS COIL HAS A POLARITY MARKING ON THE POSITIVE LEAD WHICH MUST BE

OBSERVED. OTHERWISE THE BREAKER WILL NOT HAVE OVERLOAD OR FAULT PROTECTION WHICH COULD RESULT IN BODILY INJURY AND/OR SERIOUS EQUIPMENT DAMAGE.

**Terminals marked "test point" are intended to provide connections for operation of the optional test kit.

8.2 THE AMPTECTOR I-A TRIP UNIT

Amptector I-A trip units perform all of the functions described above for Amptector II-A trip units and in addition provide the following:

1. Optional adjustable ground fault protection with resettable operation indicator.
2. All Amptectors I-A have a trip indicator that will indicate on overload tripping and another that indicates on short circuit tripping. (All indicators are reset manually.)

Figure 62 shows the front of the Amptector I-A trip unit. A maximum of seven adjustable controls with screwdriver adjustments may be provided for setting the following characteristics:

1. Long-delay current pick-up
2. Long-delay time
3. Short-delay current pick-up
4. Short-delay time
5. Instantaneous current pick-up
6. Ground current pick-up
7. Ground delay time

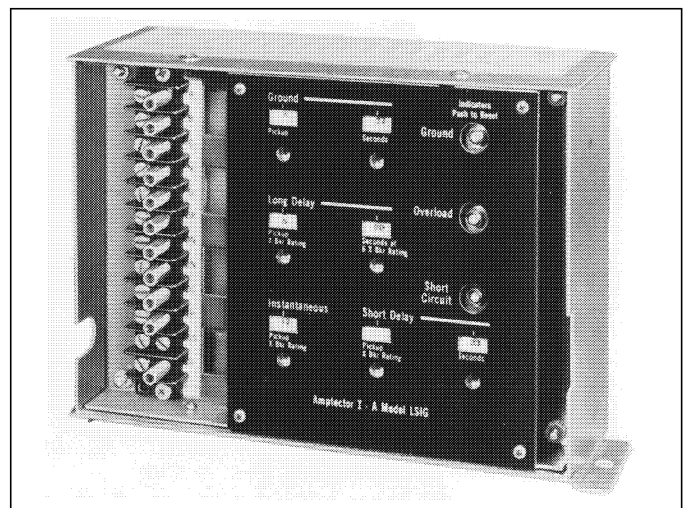

Fig. 62 Optional Amptector I-A Solid-State Trip Unit (396707)

Figure 63 is the Amptector trip unit with front cover removed, showing all of the calibration marks on the dials and trip indicators. The ranges of current settings in multiples of sensor rating and time delay are as follows:

1. Long-delay pick-up .5 to 1.25 X sensor rating
2. Long-delay 4 to 36 seconds, at 6 X sensor rating

Over these ranges tripping will always occur within the time band shown on Curve No. 2, page 60. The bottom of the band is called the resettable delay. If the overload subsides in less than the resettable delay time, resetting of the Amptector trip unit will occur within a few cycles after the load drops to less than 90% of the pick-up setting.

3. Short-delay pick-up 4 to 10 X sensor rating
4. Short delay .18 seconds to .50 seconds or 11 to 30 cycles at 60 Hz, at 2.5 X pick-up setting.

Over these ranges tripping will always occur within the time band shown on Curve No. 2, page 60. Although the time adjustment is continuous, three time bands are calibrated as shown on the curve.

5. Instantaneous pick-up 4 to 12 X sensor rating

6. Ground current pick-up See table on top of trip unit or on Curve No. 2
7. Ground delay time .22 to .50 seconds
13 to 30 cycles at 60 Hz

Six different combinations of the above trip elements are provided. These combinations with the corresponding Amptector I-A model designations are as follows:

1. Long Delay Instantaneous LI
2. Long Delay Instantaneous Ground LIG
3. Long Delay Short Delay LS
4. Long Delay Short Delay Ground LSG
5. Long Delay Short Delay Instantaneous Ground LSIG
6. Long Delay Short Delay Instantaneous LSI

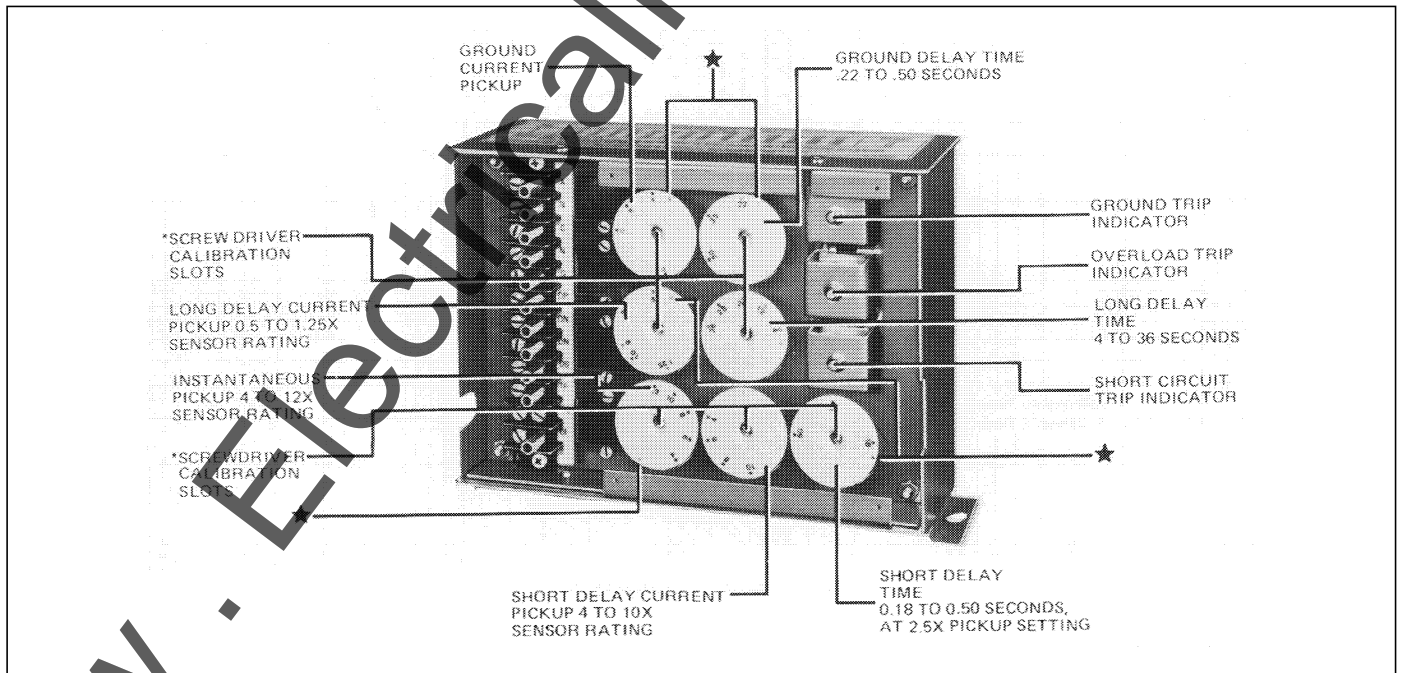

*See Section 8.4 of Text for Explanation

Fig. 63 Amptector I-A Trip Unit with Front Cover Removed (396706)

Application Data 32-860

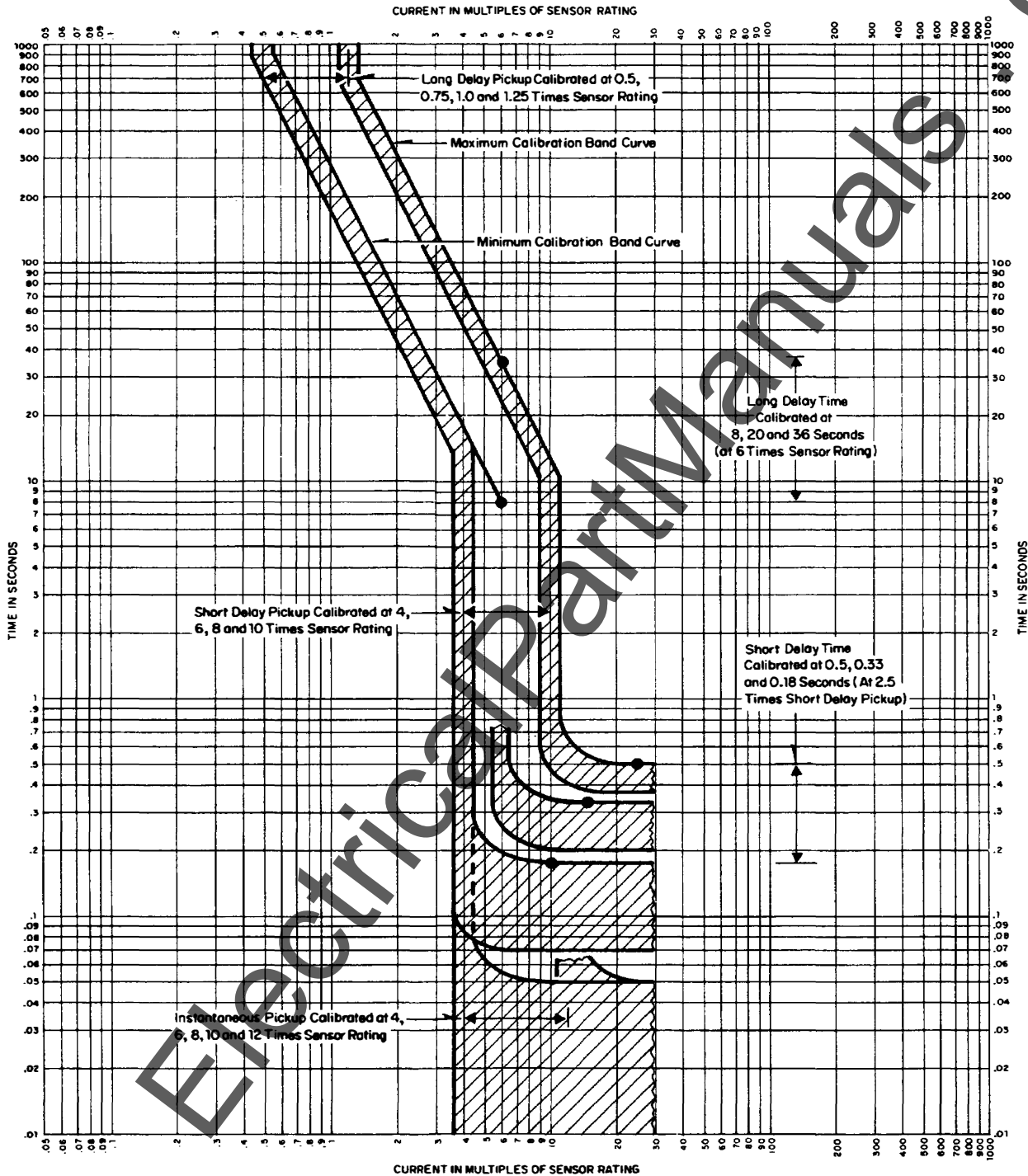

Amprector II-A
Time - Current Characteristics

Curve No. 1

Curve No. 705502

New Information
November, 1978

Application Data 32-860

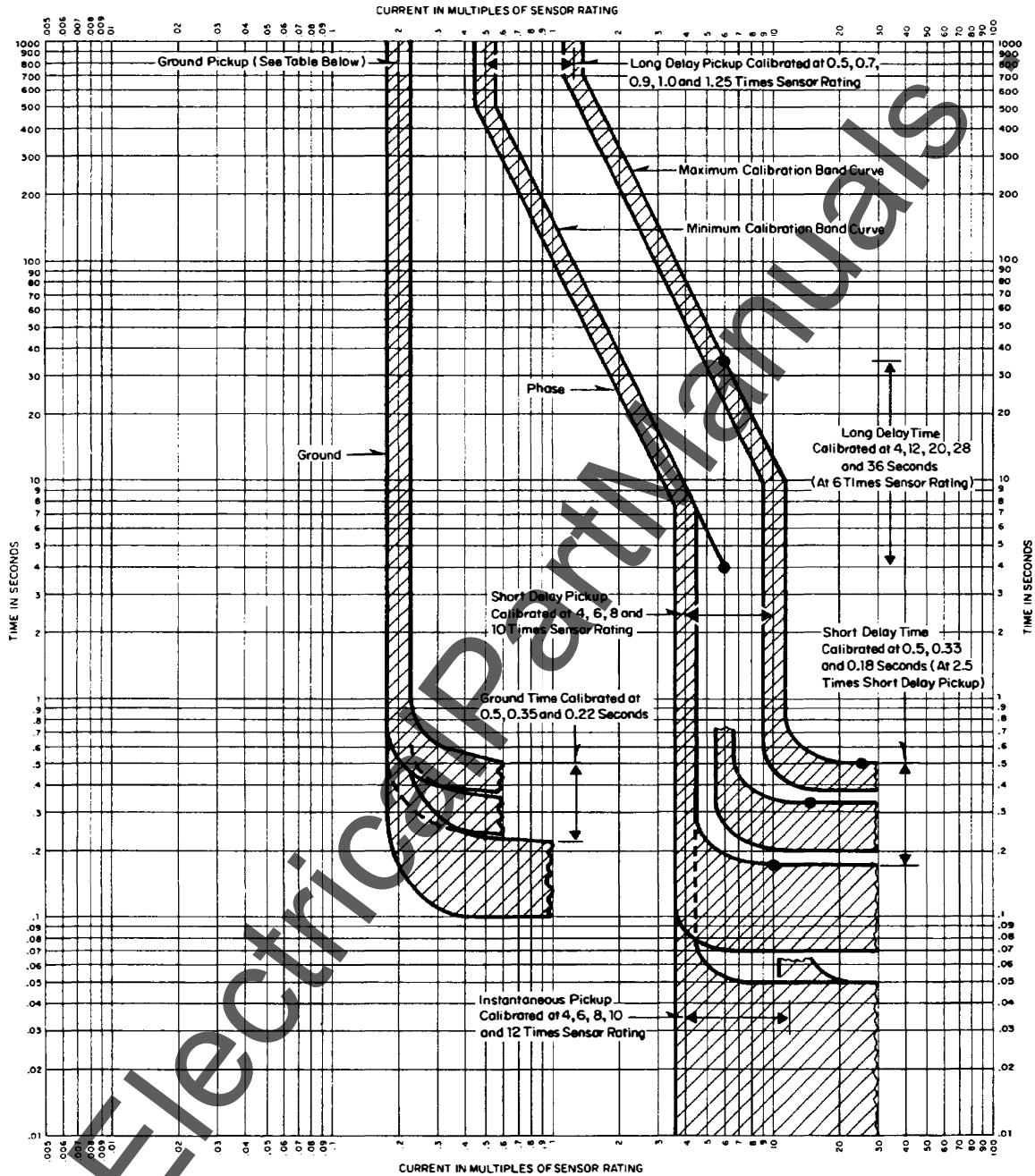

Amptector I-A		Ground Pick Up Values in Amperes												Secondary Current	
Dial Setting	50	100	150	200	300	400	600	800	1200	1600	2000	2400	3200		4000
A	13	57	60	85	110	145	180	260	330	400	530	640	800	1000	1.0
B	18	67	75	85	110	150	205	260	385	505	600	770	1000	1200	1.5
C	22	75	85	100	130	185	250	325	480	625	760	960	1200	N.A.	1.9
D	33	100	120	145	200	270	385	500	730	970	1200	N.A.	N.A.	N.A.	3.0

All pick up values may vary $\pm 10\%$.
 * Current of this value from the secondary of an external ground transformer will cause the ground element to function. Ground element pick-up can also be tested using this value. All sensors must be disconnected during test.

Amptector I-A
 Time - Current Characteristics

Curve No. 2

Curve No. 705501
 New information
 November, 1978

Each Amptector I-A trip unit has a terminal block equipped with test plug terminals accessible on the front of the circuit breaker front panel. This permits convenient field checking of calibrations and operation with an external power supply. A specially designed power supply test kit, with plugs to match the Amptector trip unit test plug terminals is available; and its operation is described in Section 8.7.6 of this instruction book.

Figure 59 shows a typical standard wiring diagram, which includes the Amptector trip unit terminal block. The following table explains the markings of the terminals:

A	Sensor phase A
B	Sensor phase B
C	Sensor phase C
N	Sensor neutral
G	Ground
OP	Output positive *
ON	Output negative*
DN	Test point (internal neutral)**
DS	Test point**
TP	Test point **
OSS	High load switch signal to accessory unit
DI	Test point **

*To Actuator Coil. THIS COIL HAS A POLARITY MARKING ON THE POSITIVE LEAD WHICH MUST BE OBSERVED. OTHERWISE THE BREAKER WILL NOT HAVE OVERLOAD OR FAULT PROTECTION WHICH COULD RESULT IN BODILY INJURY AND/OR SERIOUS EQUIPMENT DAMAGE.

**Terminals marked "test point" are intended to provide connections for operation of the optional test kit.

8.2.1 Ground Fault Protection

When the Amptector I-A trip unit includes ground current protection, the type of connection to the circuit must be considered. If the system neutral is grounded but the neutral is not carried with the phase conductors, the Amptector trip unit has all of the equipment necessary for sensitive ground protection.

If the system neutral is grounded and a neutral conductor is carried with the phase conductors, it is necessary to order an additional sensor, for the purpose of cancelling out any residual current in the phase conductors. This sensor must be mounted separately and must be located on the neutral conductor at the point where the neutral

conductor connects to the neutral bus. These sensors are duplicate of those supplied on the breaker except for the 2400A and 3200A ratings where a modified neutral sensor is required.

The Amptector trip unit ground element may be energized from an external ground current source rather than from internally developed ground current. Such an external source could be a ring-type transformer through which all the load current conductors would have to pass. In the case of a three-phase four-wire circuit all three phase conductors and the neutral conductors would have to pass through the transformer. The sensitivity of the ground element for this kind of arrangement would depend on the ratio of the transformer used.

The ground current pick-up dial on the Amptector I-A trip unit has alphabetic calibration markings. The actual ground current corresponding to these calibrated points varies with the rating of the sensor being used. These pick-up values are printed on the top of the trip unit box.

The "Ground Trip Indicator" is a metal plunger located at the upper right corner of the trip unit. If the trip unit has functioned due to a ground fault, this plunger will protrude through the faceplate of the unit. The indicator is reset by pushing in on the plunger. If it is not reset before placing the breaker back in service, the trip unit will function normally but there will remain a false indication.

Overload Trip Indicator - Functions due to overload currents less than short delay or instantaneous pick-up.

Short Circuit Trip Indicator - Functions due to fault current in excess of short delay or instantaneous pick-up.

8.3 MAKING CURRENT RELEASE (DISCRIMINATOR)

All Amptector trip units which do not have instantaneous trip elements (Amptector II-A model SE and Amptector I-A models LS and LSG) are provided with a "making current release" which is referred to as a "Discriminator". This is a circuit in the trip unit which determines at the time of a fault whether or not there has been any current flow in the primary circuit previous to the fault. If there has been no measurable current flow previous to the fault, indicating that the circuit breaker is just being closed (or possibly that a switching device ahead of the breaker has just been closed) and if the primary current flow exceeds approximately twelve times the sensor rating, the trip unit will function instantaneously. If the "Discriminator" circuit determines that there has been a measurable current flow prior to the fault, the instantaneous operation will not occur and the normal short time delay element will take over to delay tripping. The pur-

pose of this unique tripping concept is that selectivity and continuity of service in un-faulted sections of the system can be maintained if there is any need, but if there is no previously operating load on the circuit, the instantaneous function takes over to limit extensive damage which might occur due to a delayed tripping operation.

8.4 SERVICING OF AMPTECTOR TRIP UNIT

The Amprector trip unit is the intelligence of the overcurrent protection provided by the breaker. It is a device that has many solid-state components. Since the only moving parts are the adjustments, the Amprector trip unit will give long, trouble-free service. All components and connections, including the printed circuit board itself are coated to give effective environmental protection.

In changing the Amprector trip unit settings, *the dials should be moved only by means of a small screw driver inserted through the round hole in the faceplate directly below the calibration window.* The shafts must never be rotated by applying torque directly to the dial as it has only a friction fit on the shaft.

If it is suspected that the dial has moved on its shaft, it may be checked by means of rotating the shaft counterclockwise to the limit of travel. A dot at the end of the calibration should lineup with the index mark on the faceplate. See asterisk (*) on Figures 61 and 63.

If there is any reason to suspect that the Amprector trip unit is not operating correctly IT SHOULD NOT BE TAMPERED WITH; SINCE TAMPERING COULD RESULT IN LOSS OF VITAL OVERCURRENT PROTECTION.

Note: Warranty on the Amprector trip unit will be void if there is any evidence of tampering.

A specially designed tester is available for checking Amprector trip unit operation without using primary current. The tester can be plugged into any convenience outlet; and will pass enough current to check any pickup calibration. Time delay calibrations can also be checked. Place drawout breakers in DISCONNECT position before performing Amprector trip unit check.

Special handling and test equipment are required to service solid-state devices. If use of the tester shows that an Amprector trip unit is not operating correctly, it is strongly recommended that a spare Amprector trip unit be used; and the questionable unit be returned to the factory for service.

8.5 ACTUATOR

The actuator receives a tripping pulse from the Amprector trip unit, and produces a mechanical force to trip the

breaker. Refer to Figures 64, 65 and 24 for location and details. The actuator is made up of a permanent magnet, a disc held by the magnet, a rod acted on by a spring, a lever for tripping the breaker, and a lever for mechanically resetting the actuator. The magnet cannot pull and reset the disc against the force of the spring acting on the rod, but can overcome the spring force when the disc is in contact with the magnet pole piece. A tripping pulse from the Amprector trip unit counteracts the effect of the permanent magnet, allowing the spring to separate the disc from the magnet pole piece and move the rod to actuate the trip shaft lever. The trip shaft lever then rotates the trip shaft and trips the breaker. As the breaker opens, the left pole unit lever pin strikes the spring finger attached to the reset lever; this furnishes the assistance required to move the disc so as to close the air gap between it and the permanent magnet against the spring force. The device is reset when the disc is in contact with the magnet. If the disc is not fully reset, the trip shaft lever will hold the breaker mechanism in the trip-free condition; and the breaker cannot be reclosed.

The actuator must be replaced if it will not stay reset when the plunger has been moved to the top of its travel.

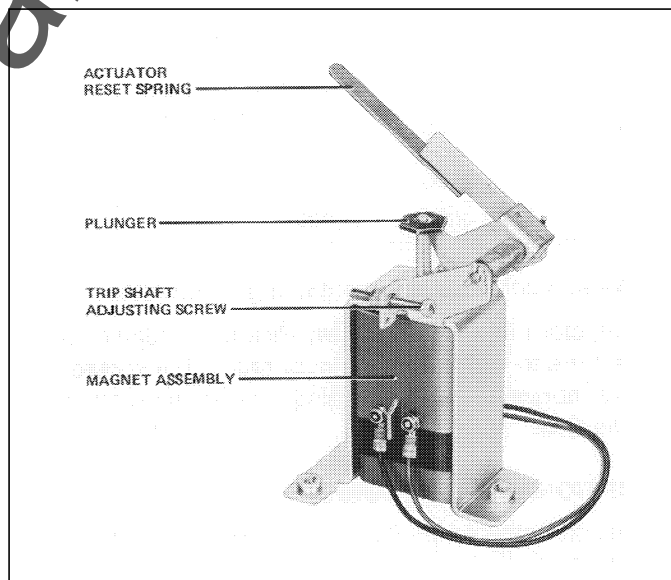

Fig. 64 Trip Actuator (391093)

8.6 SENSORS

The three sensors are located at the rear of the breaker on the lower studs, and directly behind the main disconnecting contacts. Refer to Figure 66. They produce an output proportional to the load current and furnish the Amprector trip unit with the intelligence and energy to trip