



Digitrip Retrofit System for the General Electric AK-50 Series Breakers: AK-1-50 (Frameless); AK-2-50; AK-2A-50; AKT-2A-50; AKU-2A-50; AK-3-50; AK-3A-50; and AKT-3A-50



SAFETY PRECAUTIONS



WARNING

POWER CIRCUIT BREAKERS ARE EQUIPPED WITH HIGH SPEED, HIGH ENERGY OPERATING MECHANISMS. THE BREAKERS AND THEIR ENCLOSURES ARE DESIGNED WITH SEVERAL BUILT-IN INTERLOCKS AND SAFETY FEATURES INTENDED TO PROVIDE SAFE AND PROPER OPERATING SEQUENCES. TO PROVIDE MAXIMUM PROTECTION FOR PERSONNEL ASSOCIATED WITH THE INSTALLATION, OPERATION, AND MAINTENANCE OF THESE BREAKERS, THE FOLLOWING PRACTICES MUST BE FOLLOWED. FAILURE TO FOLLOW THESE PRACTICES MAY RESULT IN DEATH, PERSONAL INJURY, OR PROPERTY DAMAGE.

- Only qualified persons, as defined in the National Electric Code, who are familiar with the installation and maintenance of power circuit breakers and their associated switchgear assemblies should perform any work associated with these breakers.

- Completely read and understand all instructions before attempting any installation, operation, maintenance, or modification of these breakers.
- **Always turn off and lock out the power source feeding the breaker prior to attempting any installation, maintenance, or modification of the breaker. Do not use the circuit breaker as the sole means for isolating a high voltage circuit. Follow all lockout and tagging rules of the National Electric Code and all other applicable codes, regulations, and work rules.**
- Do not work on a closed breaker or a breaker with the closing springs charged. Trip (open) the breaker and be sure the stored energy springs are discharged before performing any work. The breaker may trip open or the charging springs may discharge, causing crushing or cutting injuries.
- For drawout breakers, trip (open), and then remove the breaker to a well-lit work area before beginning work.
- Do not perform any maintenance: including breaker charging, closing, tripping, or any other function which could cause significant movement of the breaker while it is on the extension rails. Doing so may cause the breaker to slip from the rails and fall, potentially causing severe personal injury to those in the vicinity.
- **Do not leave the breaker in an intermediate position in the switchgear cell. Always leave it in the connected, disconnected, or (optional) test position. Failure to do so could lead to improper positioning of the breaker and flashover, causing death, serious personal injury, and / or property damage.**
- **Do not defeat any safety interlock. Such interlocks are intended to protect personnel and equipment from damage due to flashover and exposed contacts. Defeating an interlock could lead to death, severe personal injury, and / or property damage.**

Cutler-Hammer Digitrip Retrofit Kits are available in a number of configurations that provide a wide range of features. The Digitrip System starts with the 510 Basic Kit which offers true RMS sensing, overcurrent protection, and self-testing features. Advanced Digitrip Retrofit Kits feature zone interlocking, digital alphanumeric displays, remote alarm signals, IMPACC communications, energy monitoring capabilities, power factors, and harmonic content measurements.

The following table provides a quick reference of the components supplied with each level of Retrofit Kit. Before beginning the Retrofit process, take a minute to review the information contained in the table. It is important that the Retrofitter understand

which level of Retrofit Kit is to be installed and which components are included with the Kit.

The instructions contained in this manual cover the installation of all levels of Retrofit Kit. If the Kit you are installing does not contain a certain component, skip the instructions for that component and proceed to the next.

Throughout the Retrofit process, refer to the Torque Tables at the back of this manual for specific torque values.

If you have any questions concerning the Retrofit Kit and / or the Retrofit process, contact Cutler-Hammer at 1-800-937-5487.

Components	510 Basic	510 with Zone Interlock	610	810	910
Trip Unit					
Rating Plug					
Auxiliary Current Transformer (CT) Module					
Auxiliary CT Harness					
Sensors					
Sensor Harness					
Direct Trip Actuator (DTA)					
Mounting Brackets and Hardware					
External Harness	Plug	1 Connector Harness	2 Connector Harness	4 Connector Harness	4 Connector Harness
Cell Harness					
Breaker Mounted Control Power Transformer (CPT)					
Potential Transformer (PT) Module					
Auxiliary Switch					

**Beginning the Retrofit Process
Identifying the Breaker and the Retrofit Kit**





Before beginning the Retrofit Process, it is important to verify exactly which version of G. E. AK-50 Series Breaker(s) is to be Retrofitted and to insure that the correct Cutler-Hammer Retrofit Kit(s) was ordered. Each Breaker must be identified using all of the following sources that are applicable:

1. Nameplate Information;
2. Breaker Rating;
3. Framed or Frameless;
4. Fused or Non-Fused; and if fused
5. Location of Fuses
(on Top or Bottom Breaker Stabs).

Please refer to the following chart and verify that the first three (3) characters of the Digitrip Retrofit Kit Code Number correspond to the Breaker being Retrofitted. If you find that the Retrofit Kit does not match the Breaker, do not attempt the Retrofit. Contact your purchasing agent and have the correct Retrofit Kit ordered for the Breaker.

Following the Icons to a Successful Retrofit

During certain parts of the Retrofit Process, procedures may differ depending on the version of the Breaker being Retrofitted. To enable the Retrofitter to quickly identify the correct procedures for the Breaker, the following Icon System has been developed. As you are working through a procedure and the Icons appear, simply follow **only** the instructions identified by the Icon for the Breaker being Retrofitted.

Digitrip Retrofit Kit Code	Breaker ID	Breaker Rating (Amps)	Fuse Configuration	Icon
Frameless Breaker with NO Fuses				
GMC	AK-1-50	1600	N.A.	
Framed Breaker with NO Fuses				
G2C	AK-1-50 AK-2-50 & AK-2A-50 AK-3-50 & AK-3A-50	1600	N.A.	
Framed Breaker with BOTTOM Mounted Fuses				
G2C	AK-1-50 AK-2-50 & AK-2A-50 AK-3-50 & AK-3A-50	1600	Horizontal	
Framed Breaker with TOP Mounted Fuses				
GUC	AKU-2A-50	1600	Horizontal or Vertical	
Framed Breaker with NO Fuses				
GTD	AKT-2A-50 & AKT-3A-50	2000	N.A.	

Step 1: General Breaker Preparation

Before attempting to remove the Breaker from the Cell or perform any Retrofit Operation, be sure to read and understand the Safety Precautions section of this manual. In addition, be sure to read and understand the Instructions for the Application of Digitrip RMS Retrofit Kits on Power Circuit Breakers (Retrofit Application Data - Publication AD 33-855-1), supplied with the Digitrip Retrofit Kit.

NOTE: For Breakers Utilizing a Remotely Mounted Neutral Sensor Connected to the Breaker via Neutral CT Disconnect Only. The rating of the Neutral CT Disconnect, originally supplied with the Breaker, does not meet the specifications / requirements of the Retrofit Kit. The Neutral CT Disconnect must be removed and scrapped. The remotely mounted fourth Sensor must be wired into the system via Secondary Disconnects.

If the Breaker being Retrofitted is NOT equipped with Secondary Disconnects, the Secondary Disconnects for both the Breaker and the Cell, as well as all mounting brackets and hardware, must be secured from the original manufacturer of the Breaker BEFORE beginning the Retrofit Process.

- A. Trip the Breaker and remove it from the Cell. Move the Breaker to a clean, well-lit work bench.

NOTE: It is the responsibility of the Retrofitter to insure that the Breaker and all original components are in good condition. Visually inspect all Breaker components for signs of damage or wear. If any signs of damage or wear are detected for components not included in the Retrofit Kit, secure the necessary replacement parts before beginning the Retrofit Process.

The force necessary to trip the Breaker should not exceed three (3) lbs.

To begin the Retrofit Process, refer to the components list at the end of this manual. Lay out the components and hardware according to the steps outlined. The components and hardware will be used to complete each step in the Retrofit Process.

NOTE: For most photographs contained within this manual, a G. E. AK-2-50 Breaker was used as the subject. Depending on the version and age of the Breaker being Retrofitted, some components / views depicted in this manual may differ from the Breaker being Retrofitted.



WARNING

DO NOT ATTEMPT TO INSTALL OR PERFORM MAINTENANCE ON EQUIPMENT WHILE IT IS ENERGIZED. SEVERE PERSONAL INJURY OR DEATH CAN RESULT FROM CONTACT WITH ENERGIZED EQUIPMENT. VERIFY THAT NO VOLTAGE IS PRESENT BEFORE PROCEEDING.

Step 2: Removing the Original Electromechanical Trip Units

*For All G. E. AK-50 Series Breakers **Except** AK-3/3A-50, AKU-3/3A-50, and Breakers Equipped with a Quick Close Mechanism.*

Follow the G. E. AK-50 Series Instruction Manual, originally supplied with the Breaker, to perform the following procedures.

- A. Carefully lay the Breaker over on its right side to provide access to the bottom of the Breaker.
- B. Remove and scrap the original Electromechanical Trip Units and mounting hardware from each phase.
- C. Remove and scrap the Electromechanical Trip Paddles and mounting hardware from the Breaker Trip Bar.



For G. E. AK-3/3A-50, AKU-3/3A-50, and Breakers Equipped with a Quick Close Mechanism Only.

Follow the G. E. AK-3/3A-50 Series Instruction Manual, originally supplied with the Breaker, to perform the following procedures.

- A. Carefully lay the Breaker over on its right side to provide access to the bottom of the Breaker.
- B. Disconnect and scrap all wires connecting the original Electronic Trip Units, Direct Trip Actuator, and the original Sensors mounted on the bottom studs.
- C. Remove and scrap the original Sensors, Electronic Trip Units, Direct Trip Actuator, Reset Links, and all associated mounting hardware.



Note: For Breakers originally fitted with a remotely mounted Neutral Sensor, the Neutral CT Disconnect must be removed and discarded.

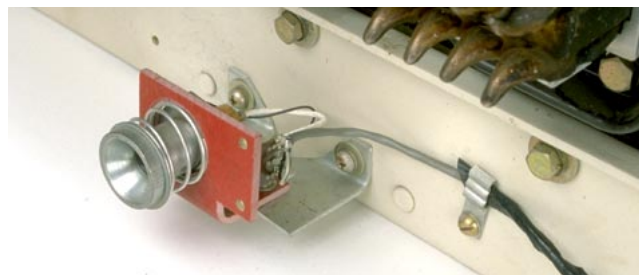

Step 3: Installing the Copper Adapters

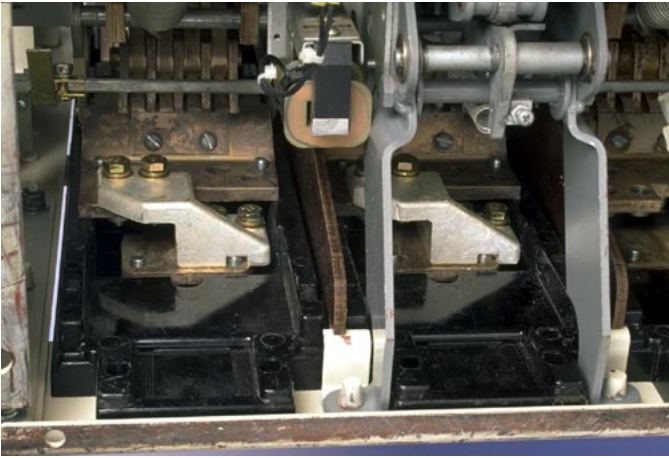

- A. Align the holes in the Copper Adapters with the holes that were used to mount the original Electromechanical Trip Units.
- B. Mount a Copper Adapter to each Phase, as shown, using the (12) .375-16 × 1.50" bolts, (12) lock washers, and (12) flat washers supplied.



For Kits Supplied with a PT Module Only.

As viewed from the front of the Breaker, do not install the left mounting bolt in each Copper Adapter. These will be used later in the Retrofit Process to attach the PT Wires to each Phase Frame.

- C. Carefully return the Breaker to the upright position.

Before proceeding, identify the section(s) within the Step that apply to the Breaker being Retrofitted.

Step 4: Installing the Sensors



Note: On Breakers equipped with a Racking Mechanism, the Sensors and Sensor Mounting Bracket provide adequate clearance between the Sensors and Racking Mechanism.



For Top Mounted Sensors Only.



- A. Align a 3-Point Terminal Block with each set of holes in the Sensor Mounting Bracket as shown. Secure the 3-Point Terminal Blocks to the Sensor Mounting Bracket using the (6) .138-32 x .500" screws and (6) lock washers supplied.
- B. Install a Flexiform Grommet to the edges of each wire cutout in the Sensor Mounting Bracket.
- C. Insert the three (3) wires exiting the top of the Sensor through the opening in the Sensor Mounting Bracket.
- D. With the Sensor Nameplate at the top and facing out, align the threaded holes in the top of the Sensor with the holes in the Sensor Mounting Bracket. Secure the Sensor to the Sensor Mounting Bracket using the (4) .250-20 x .500" bolts, (4) lock washers, and (4) flat washers supplied.
- E. Repeat Steps B and C for the remaining two (2) Sensors.



- F. Connection of the Sensor Wires to the 3-Point Terminal blocks is detailed in the photo. Once the correct connection point has been determined, cut each Sensor Wire to an appropriate length and attach a supplied ring terminal to each wire.

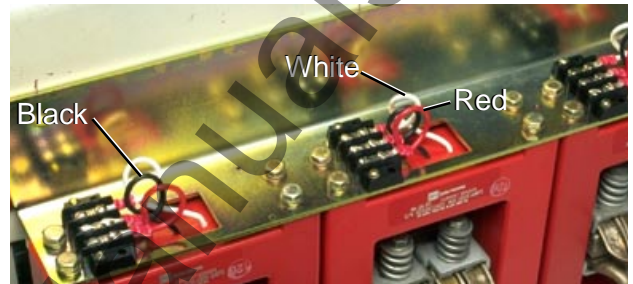

- G. Align the Sensor Mounting Bracket / Sensor Assembly with the existing holes on the top rear of the Breaker Back Plate as shown. Secure using the (2) .500-13 x 1.50" bolts, (4) flat washers, (2) lock washers, and (2) nuts supplied.



For Bottom Mounted Sensors Only.

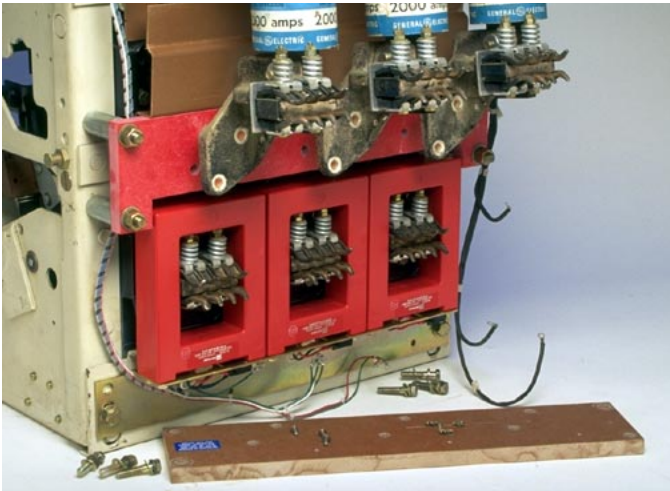

A. Following the G. E. AK-50 Series Instruction Manual originally supplied with the Breaker, remove and save the fuses, mounting brackets, and hardware.

B. Again following the G. E. AK-50 Series Instruction Manual, remove and save the hardware that secures the .750" thick Support Plate to the Breaker Back Plate. Remove and scrap the Support Plate.

C. Align the holes in the new Glass Poly Support Plate with the holes in the Breaker Plate. Note that the cutout for the Sensors must face the bottom of the Breaker. Secure the new Support Plate using the original mounting hardware.

D. Align a 3-Point Terminal Block with each set of holes in the Sensor Mounting Bracket as shown. Secure the 3-Point Terminal Blocks to the Sensor Mounting Bracket using the (6) .138-32 x .500" screws, (12) flat washers, (6) lock washers, and (6) nuts supplied.

E. Install a Flexiform Grommet to the edges of each wire cutout in the Sensor Mounting Bracket.

F. Insert the three (3) wires exiting the top of the Sensor through the opening in the Sensor Mounting Bracket.

G. With the Sensor Nameplate at the bottom and facing out, align the threaded holes in the top of the Sensor with the holes in the Sensor Mounting Bracket. Secure the Sensor to the Sensor Mounting Bracket using the (4) .250-20 x .500" bolts, (4) lock washers, and (4) flat washers supplied.

H. Repeat Steps E and F for the remaining two (2) Sensors.



I. Connection of the Sensor Wires to the 3-Point Terminal blocks is detailed in the photo. Once the correct connection point has been determined, each Sensor Wire should be cut to an appropriate length and a supplied ring terminal attached to each.

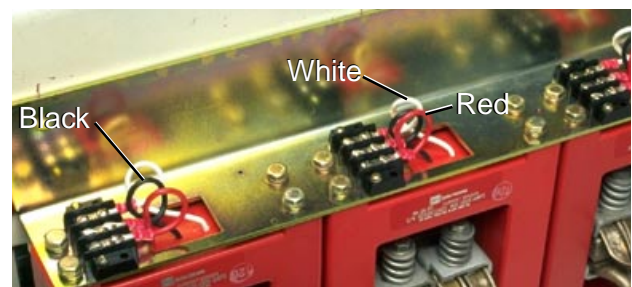

- J. Align the Sensor Mounting Bracket with the existing holes on the bottom rear of the Breaker Back Plate as shown. Secure using the (2) .500-13 × 1.50" bolts, (4) flat washers, (2) lock washers, and (2) nuts supplied.



- C. Align the threaded holes in the Sensor Adapter Brackets with the holes in the Sensor Mounting Bracket. Secure the Sensor Assembly to the Sensor Mounting Bracket using the (4) .250-20 × .500" bolts, (2) lock washers, and (2) flat washers supplied.

- D. Repeat Step B for the remaining two (2) Sensor Assemblies.



- K. Following the G. E. AK-50 Series Instruction Manual originally supplied with the Breaker, reinstall the original fuses, mounting brackets, and hardware.

For AKT-2A-50 and AKT-3A-50 2,000 Amp Breakers Only.



- E. Align the Sensor Mounting Bracket / Sensor Assembly with the existing holes on the top rear of the Breaker Back Plate as shown. Secure using the (2) .500-13 × 1.50" bolts, (4) flat washers, (2) lock washers, and (2) nuts supplied.

- A. Align two (2) Sensor Adapter Brackets with the holes in the top of the Sensor as shown (the Sensor Terminals are located on the bottom of the Sensor). Secure the Sensor Adapter Brackets to the Sensor using the (2) .250-20 × 2.75" bolts, (4) flat washers, (2) lock washers, and (2) nuts supplied.

- B. Repeat Step A for the remaining two (2) Sensors.



Step 5: Installing the Aux. CT Module



Note: Cover the region below the area to be drilled to prevent chips from falling into the Breaker.

Drilling Plan "A"

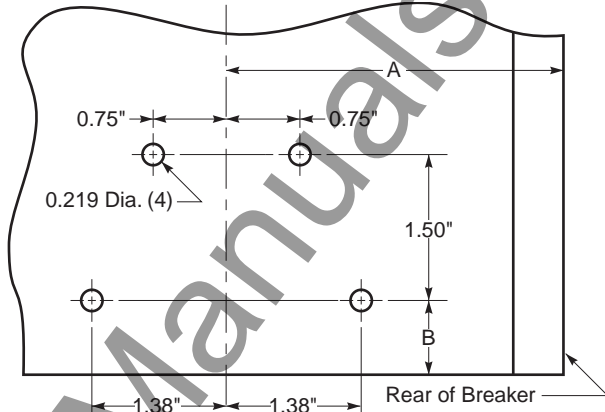

AK Breaker	A	B
Without Quick Close Mech.	6.62	0.75
With Quick Close Mech.	4.38	1.00

- A. Carefully lay the Breaker over on its left side.
- B. Using Drilling Plan "A", drill four (4) .219" diameter holes near the bottom of the right side of the Breaker. Note that the positioning of the Aux. CT Module differs slightly for Breakers equipped with a Quick Close Mechanism.
- C. Remove the screws installed in the right side of the Aux. CT Module.
- D. Align the holes in the right side of the Aux. CT Module with the holes just drilled in the right side of the Breaker. Secure the Aux. CT Module to the Breaker using the (4) .190-16 x .500" thread cutting screws, (4) flat washers, and (4) lock washers supplied.



Before proceeding, identify the section(s) within the Step that apply to the Breaker being Retrofitted.

Step 6: Installing the Sensor Harness and DTA Extension Harness

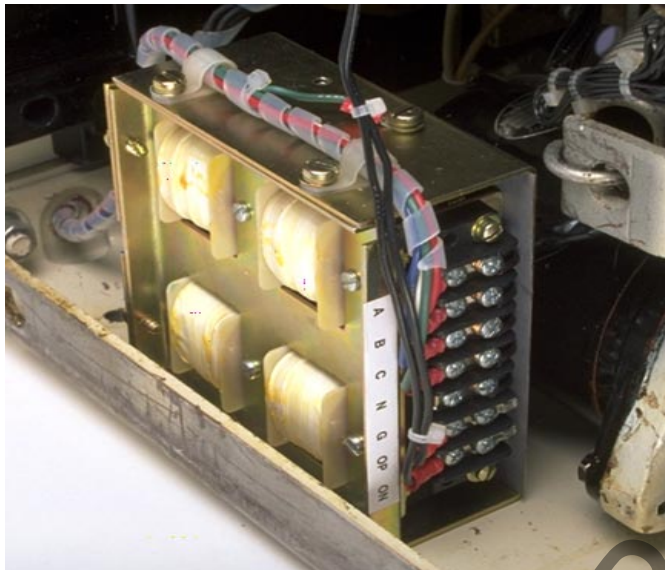

- A. Connect the Sensor Harness to the proper terminals on the Aux. CT Module. Refer to Section 12 of the Retrofit Application Data, supplied with the Retrofit Kit, for detailed wiring specifications.
- B. Using one of the screws from Step 5, connect the green ground wire from the Sensor Harness (with ring terminal) to the Aux. CT Module.

Note: The long tan and green wires are for the Remote Neutral Sensor on a 4W Ground Breaker. They should be removed if not required for the Retrofit.

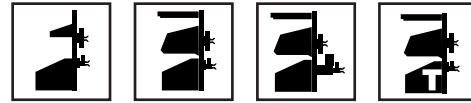
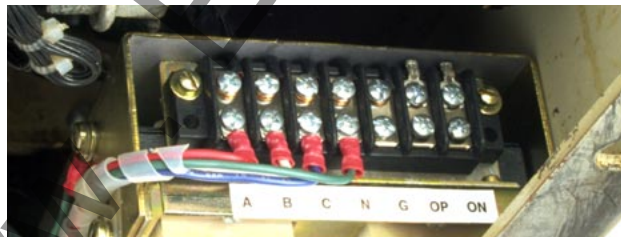

- C. Install the supplied grommet in the hole near the bottom right corner of the Breaker Back Plate.
- D. Route the Sensor Harness towards the right rear of the Breaker and through the grommet just installed.



- E. Route the Sensor Harness along the right rear of the Breaker Back Plate up to the Sensors.



Connect the ring terminals of the Sensor Harness to the 3-Point Sensor Terminal Blocks. Refer to Section 12 of the Retrofit Application Data, supplied with the Retrofit Kit, for detailed wiring specifications.





Connect the ring terminals of the Sensor Harness to the Sensor Terminals. Refer to Section 12 of the Retrofit Application Data, supplied with the Retrofit Kit, for detailed wiring specifications.



For Kits Supplied with a PT Module Only.
Refer to Section 7-3, Power Flow Convention, of the Retrofit Application Data, supplied with the Retrofit Kit, for additional wiring information and to verify the Phase Convention used on this Breaker Application.

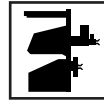

- C. Install the supplied grommet in the hole near the top right corner of the Breaker Back Plate.
- D. Route the Sensor Harness towards the right rear of the Breaker, then up along the inside of the Breaker and through the grommet just installed.
- E. Route the Sensor Harness along the right rear of the Breaker Back Plate down to the Sensors. Connect the ring terminals of the Sensor Harness to the 3-Point Sensor Terminal Blocks. Refer to Section 12 of the Retrofit Application Data, supplied with the Retrofit Kit, for detailed wiring specifications.

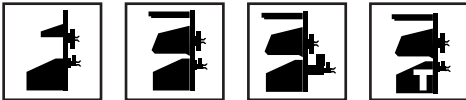

Depending on the Sensors supplied with the Retrofit Kit, the following conventions apply.

Sensor Style No.

8256A98H01	X1-X2 = 2000A
4A35733H01	X1-X3 = 1600A X1-X2 = 800A
4A35734H01	X1-X3 = 800A X1-X2 = 400A

X1 - White, X2 - Black, X3 - Red

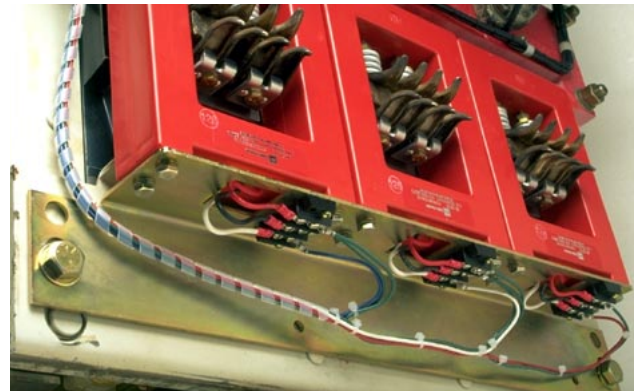

Depending on the Sensors supplied with the Retrofit Kit, the following conventions apply.

Sensor Style No.

4A35733H01	X1-X3 = 1600A X1-X2 = 800A
4A35734H01	X1-X3 = 800A X1-X2 = 400A

For Kits Supplied with a PT Module Only.
 Refer to Section 7-3, Power Flow Convention, of the Retrofit Application Data, supplied with the Retrofit Kit, for additional wiring information and to verify the Phase Convention used on this Breaker Application.



F. Connect the “+” wire of the DTA Extension Harness to the “OP” terminal of the Aux. CT Module and the unmarked wire to the “ON” terminal. Route the DTA Extension Harness inside the Breaker towards the left front corner.

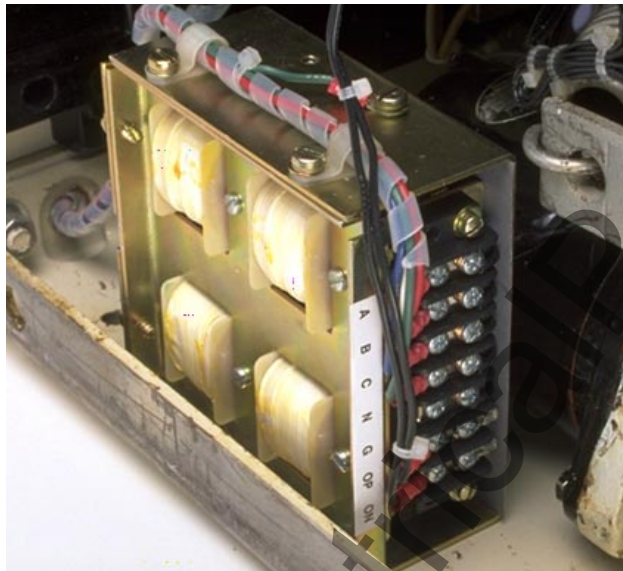

G. Use the nylon wire ties and clamps supplied to dress all wires to keep them away from any moving parts within the Breaker.

H. Carefully return the Breaker to its normal, upright position.

Step 7: Installing the DTA Assembly

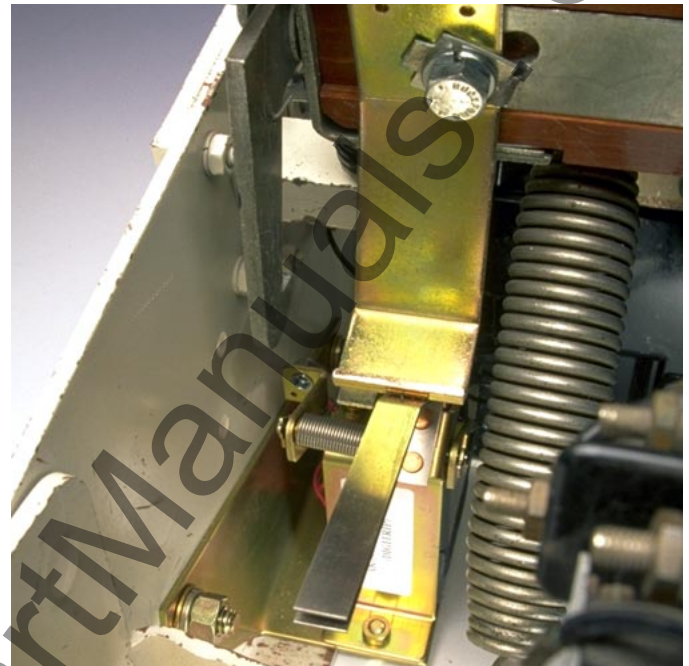

A. With the Breaker in the OPEN position and with the Breaker Closing Springs DISCHARGED, mount the Trip Finger on the Breaker Trip Bar, as shown, using the (1) .250-20 × .750" carriage bolt, (1) flat washer, (1) lock washer, and (1) nut supplied. Do not tighten hardware at this time. The Trip Finger should be free to move on the Trip Bar.

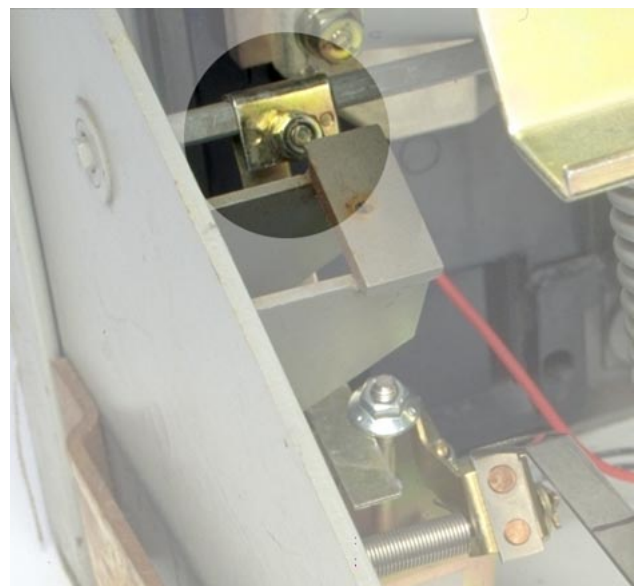

- B. Position the DTA Assembly near the front of the Breaker. Route the DTA Extension Harness from the Aux. CT Module under the front of the Breaker to the 2-Point Terminal Block mounted on the DTA Assembly. Connect the "+" wire of the DTA Extension Harness to the same terminal as the DTA Wire marked "+". Connect the unmarked wire of the DTA Extension Harness to the same terminal as the unmarked DTA Wire.
- C. Carefully tilt the Breaker back and slide the DTA Assembly under the front of the Breaker. Position the DTA Assembly near the left front of the Breaker with the 2-Point Terminal Block facing the rear of the Breaker. Lower the front of the Breaker, being careful not to damage the DTA Assembly.
- D. Align the DTA Assembly with the existing holes near the bottom front of the Left Breaker Frame. Apply Loc-Tite® 242 to the threads then secure the DTA Assembly, as shown, using the (2) .375-16 × 1.00" bolts, (4) flat washers, (2) lock washers, and (2) nuts supplied.

Note: On some breakers, a Ground Shoe may have been mounted to the holes used to mount the DTA Assembly. When mounting the DTA Assembly, the Ground Shoe MUST BE reinstalled and secured to the Breaker using the ORIGINAL mounting hardware.



- E. With the Breaker in the OPEN position and with the Breaker Closing Springs DISCHARGED, slide the Trip Finger (attached to the Breaker Trip Bar in Step 7-A) over so that it is located under the left hand side of the DTA flange nut.
- F. Position trip finger with a HORIZONTAL GAP of 0.03" to 0.12" to the DTA shaft.

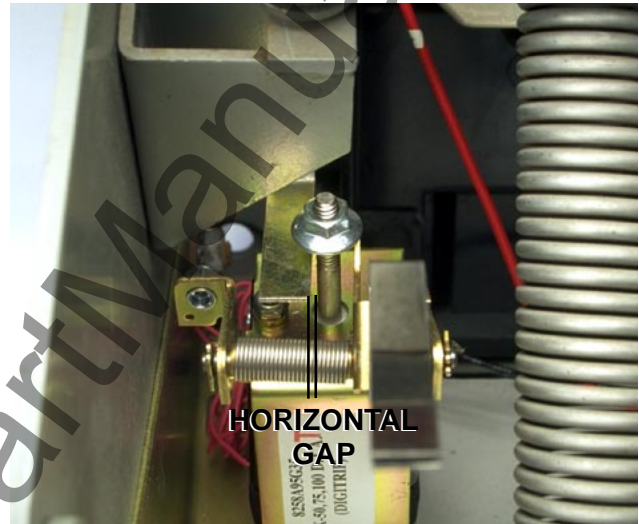

- G. Tighten trip finger mounting hardware. Recheck horizontal gap and reposition the Trip Finger if necessary.
- H. Verify DTA Assembly is reset. Manually reset if necessary.



WARNING

DO NOT apply more than 5 lbs. force to the end of the Reset Spring when manually resetting. Excessive force can bend the springs, resulting in a failure of the DTA Assembly to reset during normal operation.

- I. Close the breaker.



WARNING

Guard against the Breaker unintentionally OPENING during the following steps. Keep hands and fingers away from the Breaker Crossbar.

- J. Manually raise the DTA Assembly Reset Spring until DTA flange nut touches Trip Finger. Measure this movement at the end of the DTA reset spring. The movement should be within the range of 0.19" to 0.56". This corresponds to a VERTICAL GAP of 0.06" and 0.19" from the Trip Finger to the DTA flange nut.

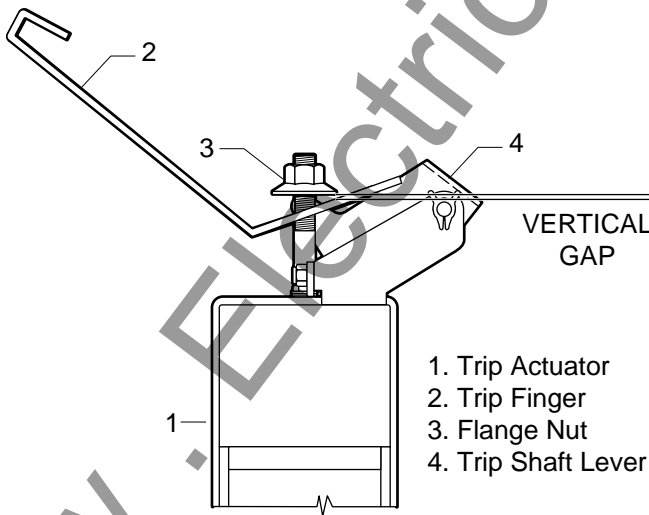
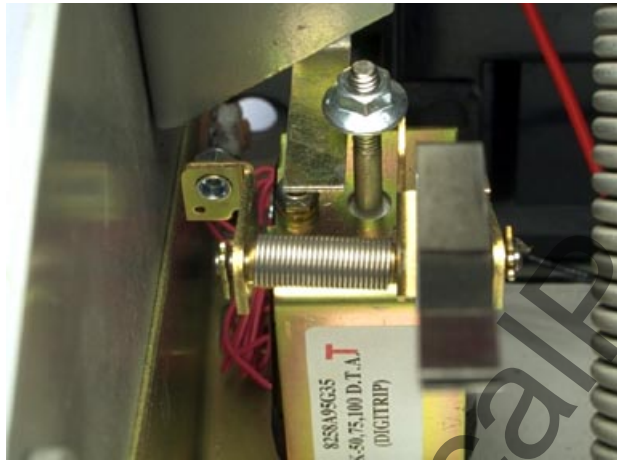

- K. Verify DTA trips the Breaker by applying 24 VDC to DTA terminals.

- L. With Breaker in the OPEN position, remove the original .375-16 x 1.50" hex bolt from the left hand side of the Breaker Cross Bar. Mount the DTA Reset Arm to the Cross Bar with the bolt just removed. After tightening, be sure to lock the bolt head with the locking clip.

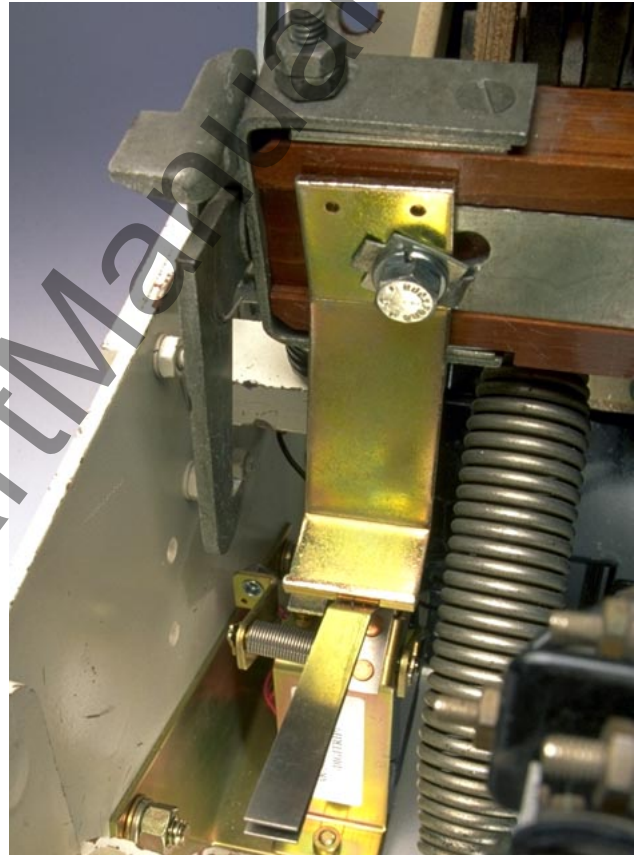

- M. Cycle the Breaker five (5) times (closing the Breaker then tripping with the DTA per Step K), verifying reliable tripping of the Breaker.

Before proceeding, identify the section(s) within the Step that apply to the Breaker being Retrofitted.

Step 8: Installing the Breaker Mounted CPT



- A. Align the CPT with the holes in the CPT Mounting Bracket as shown. Secure the CPT to the mounting bracket using the (4) .190-32 x .500" screws, (8) flat washers, (4) lock washers, and (4) nuts supplied.



- B. Align the Glass Poly Insulation with the holes in the CPT Mounting Bracket as shown. Secure the CPT to the mounting bracket using the (2) .190-32 x .625" nylon screws, (2) nylon flat washers, (2) steel flat washers, (2) lock washers, and (2) nuts supplied. Note that the screws are inserted through the Glass Poly Insulation first and then through the CPT Mounting Bracket. The nylon flat washers **MUST BE** used between the screw head and the Glass Poly Insulation.





- C. Using Drilling Plan "B", drill two (2) .312" holes in the bottom of the right front Breaker Bottom Channel as shown.

Note: Cover the area below the location in which the holes will be drilled to prevent the drilling chips from falling into the Breaker.

Drilling Plan "B"

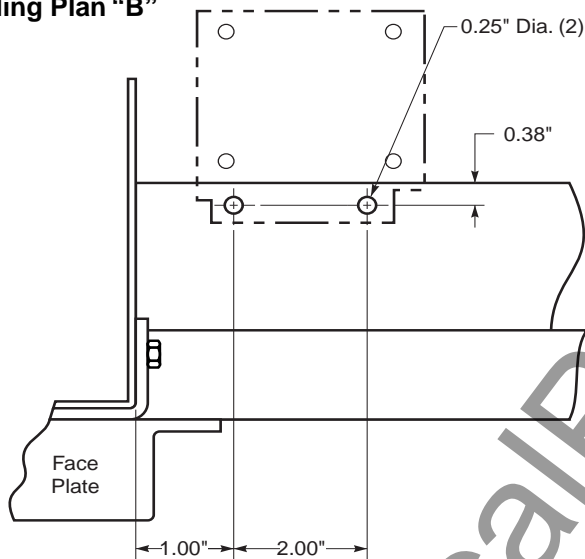

- D. Align the CPT Assembly with the holes just drilled. Secure the CPT Assembly to the Breaker using the (2) .250-20 x .625" bolts, (4) flat washers, (2) lock washers, and (2) nuts supplied.

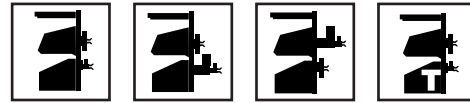
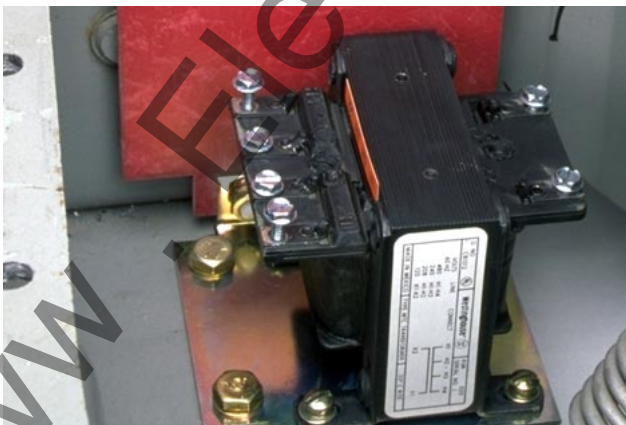

- C. Using Drilling Plan "C", drill two (2) .312" holes in the left side of the Top Breaker Channel.

Note: Cover the area below the location in which the holes will be drilled to prevent the drilling chips from falling into the Breaker.

Drilling Plan "C"

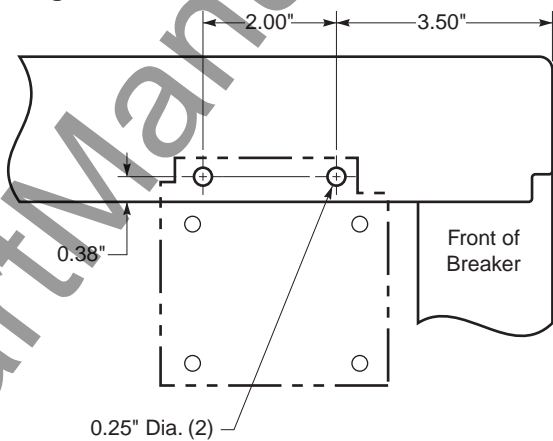

- D. Align the CPT Assembly with the holes just drilled. Secure the CPT Assembly to the Breaker using the (2) .250-20 x .625" bolts, (4) flat washers, (2) lock washers, and (2) nuts supplied.



Before proceeding, identify the section(s) within the Step that apply to the Breaker being Retrofitted.

Step 9: Installing the Trip Unit

Frameless



- A. Using Drilling Plan "D", mark and drill two (2) .312" diameter holes in the top flange of the bottom right Breaker Channel.

Note: Cover the area below the location in which the holes will be drilled to prevent the drilling chips from falling into the Breaker.

Drilling Plan "D"

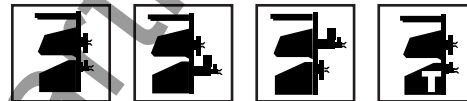
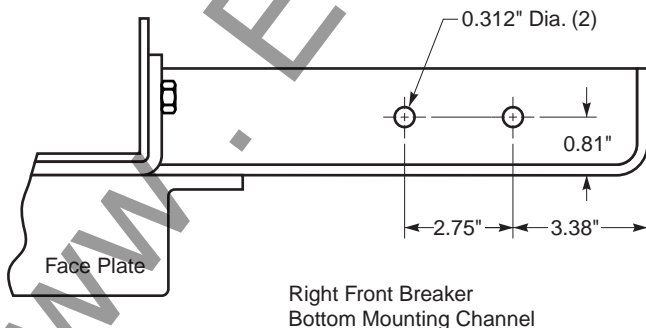

- A. Using Drilling Plan "E", mark and drill two (2) .312" diameter holes in the right side of the middle Breaker Channel.

Note: Cover the area below the location in which the holes will be drilled to prevent the drilling chips from falling into the Breaker.

Drilling Plan "E"

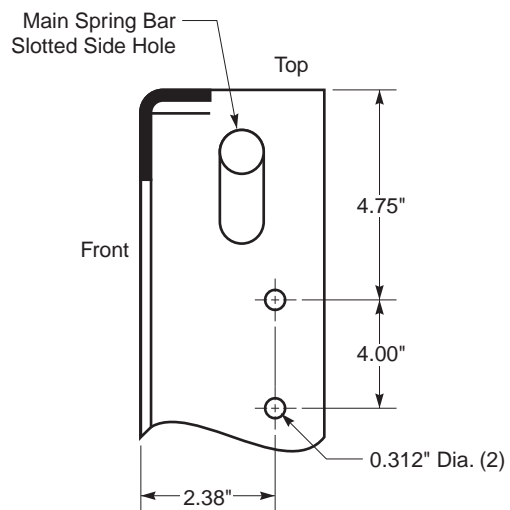

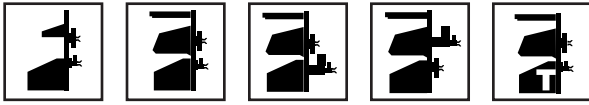

B. Mount the left-hand (the larger Bracket with cut-out) and right-hand Trip Unit Mounting Brackets, as shown, to the Glass Poly Barrier using the (2) .190-32 x .500" steel screws, (2) .190-32 x .625" nylon screws, (6) steel flat washers, (2) nylon flat washers, (4) lock washers, and (4) nuts supplied.

Note: The nylon screws and flat washers are to be used in the top holes and the steel screws and flat washers are to be used in the bottom holes. The screw heads must be on the Glass Poly Barrier side of the assembly.



C. *For Kits Supplied with an Auxiliary Switch Only.* Using a pair of diagonals, cut 4" off the end of the Microswitch Arm. Mount the Microswitch to the Auxiliary Switch Mounting Bracket, as shown, using the (2) .138-32 x 1.00" screws, (4) flat washers, (2) lock washers, and (2) nuts supplied.

Note: The orientation of the Microswitch is different for the Frameless versus the Framed Breakers.

Mount the Auxiliary Switch Assembly to the bottom of the right-hand Trip Unit Mounting Bracket Assembly, using the (1) .138-32 x .375" screw, (2) flat washers, (1) lock washer, and (1) nut supplied.

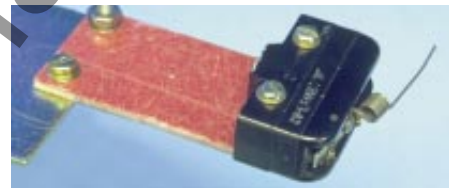
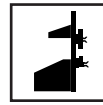

D. *For Kits Supplied with a PT Module Only.* Remove the "L" Mounting Bracket, Warning Label Plate, and Connector from the Potential Transformer (PT) Module.



Using the original hardware, reconnect the "L" Mounting Bracket, New Warning Label Plate, and the Connector to the side of the PT Module as shown.



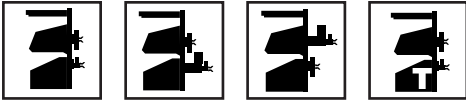

Scrap the Warning Label Plate and “L” Bracket. Rotate the connector 90° then reconnect it to the PT Module, as shown, using the original hardware.



Mount the PT Module to the right-hand Trip Unit Mounting Bracket, using the (2) .138-32 × .375" screws, (2) flat washers, and (2) lock washers supplied. The Glass Poly Insulation Barrier must be positioned between the PT Module and the Trip Unit Mounting Bracket.



E. Mount the Trip Unit to the Trip Unit Mounting Bracket Assembly, as shown, using the (4) Brass Spacers, (2) .190-32 × 5.00" screws, (4) flat washers, (2) lock washers, and (2) nuts supplied.

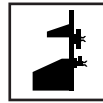

F. Align the holes in the “L” shaped Trip Unit Mounting Bracket with the holes drilled in the Breaker Channel in the applicable Step 8-A. Secure the Mounting Bracket to the Breaker Channel using the (2) .250-20 × 1.00" bolts, (4) flat washers, (2) lock washers, and (2) nuts supplied.

Mount the Trip Unit Assembly to the pre-drilled holes in the top of the “L” shaped Trip Unit Mounting Bracket, installed in Step 8-B, using the (2) .250-20 × .750" bolts, (4) flat washers, (2) lock washers, and (2) nuts supplied.

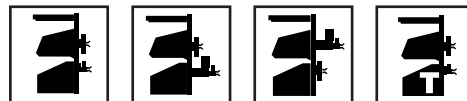

F. Align the holes in the Trip Unit Assembly with the holes drilled in the right side of the middle Breaker Channel in the applicable Step 8-A. Secure the Trip Unit Assembly to the Breaker Channel using the (2) .250-20 × .750" bolts, (4) flat washers, (2) lock washers, and (2) nuts supplied.

For Kits Supplied with a PT Module Only.
Install the supplied PT Module Warning Label to the top right of the Breaker in front of the PT Module.



- G. Remove Trip Unit Cover and install the Rating Plug. Replace the cover.



Before proceeding, identify the section(s) within the Step that apply to the Breaker being Retrofitted.

Step 10: Connecting the CPT to the Breaker Stabs

- A. Position the fuses in an accessible location then mark and cut the Load Side of each High Voltage Fused Wire (HV Wire). Strip .250" from each Load Side HV Wire and attach a .138" ring terminal to each. Attach the HV Wires to the CPT terminals to achieve the required voltage. (See the following Table.)

Voltage Required	CPT Terminals Used
480 Volt Circuit	H1 & H4
240 Volt Circuit	H1 & H3
208 Volt Circuit	H1 & H2

NOTE: The power convention of the AK-50 Series Breakers is normally Top to Bottom, meaning the Top Breaker Stabs are on the Line Side of the Breaker and the Bottom Breaker Stabs are on the Load Side.

The HV Wires from the CPT **MUST BE ATTACHED** to the *Line Side* of the Breaker. If it is determined that the power flow for the Breaker application is opposite the normal convention, the HV Wires must be attached to the **Bottom Breaker Stabs**.

- B. Route the HV Wires towards the back of the Breaker, over the Backplate, then down towards the appropriate Breaker Stabs (Phase 1 and 2, or 2 and 3).

NOTE: The Line Side HV Wires are longer than necessary and are cut during the following steps. Before cutting the wires, be sure that sufficient length is left so that the HV Wire Fuses are accessible from the top of the Breaker and that the connections can be made to the correct Breaker Stabs.

- C. Drill a .172" hole in the appropriate Breaker Stabs. Tap each hole using a .190-32 bottom tap.



NOTE: For GUC Breakers Only. Additional holes do not have to be drilled and tapped in the Breaker Stabs to connect the HV Wires. The hardware securing the fuses to the Stabs can be used to connect the HV Wires.

- D. Cut the HV Wires to the appropriate length for attachment to the appropriate Phase. Strip .250" from each HV Wire and attach a .190" ring terminal. Connect the HV Wires to the Breaker Stabs using the (2) .190-32 x .500" screws, (2) lock washers, and (2) flat washers supplied.

- E. *For Kits Supplied with a Breaker Mounted CPT Only.* Remove the External Harness plug installed in the bottom rear socket on the right side of the Trip Unit. Insert the black plug of the CPT Harness into the same socket. Reinsert the External Harness plug just removed into the female receptacle on the CPT Harness.

Route the two (2) wires of the CPT Harness to the X1 and X2 terminals of the CPT. Assure that the wires are clear of any moving parts within the Breaker.

Cut the wires to length. Strip .250" of insulation and attach a .138" ring terminal to each wire. Connect the wires to the X1 and X2 terminals of the CPT.

- F. Use the nylon wire ties provided to dress the HV Wires and keep them away from any moving parts within the Breaker.
- G. Attach the appropriate label for the Breaker to the Breaker Cover in a clearly visible position. Three (3) labels are included with the CPT, one (1) for 480 Volt, one (1) for 240 Volt, and one (1) for 208 Volt systems.



Before proceeding, identify the section(s) within the Step that apply to the Breaker being Retrofitted.

Step 11: Final Connection of the Harnesses and Wiring

Frameless

Framed



- A. *For Kits Supplied with a PT Module Only.* Route the PT Wires down through the Breaker to the Copper Adapters installed in Step 3. Route them so that they are clear of all moving parts within the Breaker.

The PT Wires are marked for connection to Phases 1, 2, and 3 with corresponding numbers.

NOTE: Before cutting the PT Wires, verify the Phase Convention used on the Breaker Application.

Route the PT Wires to a position suitable for attachment to the proper Copper Adapters. Move the PT Wire markers to a position where they will still be attached to the wires after cutting. Cut the wires to length, strip each wire .250", and install a .380" ring terminal on each wire.

Connect each PT Wire to its corresponding Copper Connector using the .375" bolts left loose in Step 3.

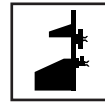
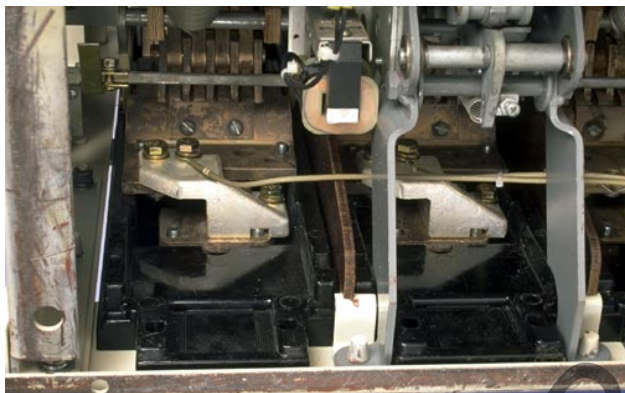

- D. Secure the External Harness to the Trip Unit "L" shaped Mounting Bracket, as shown, using the (2) nylon wire clamps and the (2) .138 x .380" thread cutting screws supplied.



- B. Plug the Aux. CT Harness into the Aux. CT Module. Route the Aux. CT Harness up along the Breaker to the bottom of the Trip Unit then plug it into the Trip Unit.
- C. Connect the External Harness to the Trip Unit.



- D. Drill two (2) .164" holes in the right side of the Breaker Frame. Secure the External Harness to the holes just drilled using the (2) nylon wire clamps and the (2) .138 x .380" thread cutting screws supplied.



NOTE: For 510 Basic Kits, the External Harness is the plug pictured above. It is to be plugged into the right side of the Trip Unit.





- E. *For Kits Supplied with a PT Module Only.*
Connect the plug from the PT Module to the corresponding plug on the External Harness.



- F. *For Kits Supplied with an Aux. Switch Only.*
Connect the two (2) wires with ring terminals from the External Harness to the Microswitch. Connect one (1) wire to the normally closed terminal and the other wire to the common terminal.

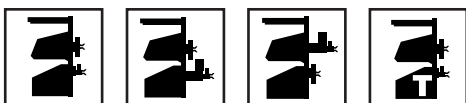

- F. *For Kits Supplied with an Aux. Switch Only.*
Connect the two (2) wires with ring terminals from the External Harness to the Microswitch. Connect one (1) wire to the normally open terminal and the other wire to the common terminal.

- H. Use the nylon wire ties provided to dress all wires and harnesses to keep them away from any moving parts within the Breaker.

Step 12: Testing the Breaker

- A. Measure the force necessary to trip the Breaker at the point where the DTA flange nut contacts the Trip Finger. The force necessary to trip the Breaker **MUST NOT EXCEED 3 lbs.**
- B. The Retrofit must be tested using primary injection. Refer to Section 8 of the *Instructions for the Application of Digitrip RMS Retrofit Kits on Power Circuit Breakers* (Publication AD 33-855-1, June, 1997), supplied with the Retrofit kit, for detailed testing procedures and specifications. For test information specific to the Trip Unit, refer to the IL publication supplied with the Retrofit kit (see the Pick List for the IL number).
- C. While Section 8 of the *Instructions for the Application of Digitrip RMS Retrofit Kits on Power Circuit Breakers* provides the information necessary for testing the Breaker, please keep the following notes in mind when reviewing other sections of the publication.

CAUTION: When all testing is complete, the Trip Unit must be reset. Failure to do so may cause the Battery in the Rating Plug to run down.

Notes:

1. Publication AD 33-855-1 was created specifically for the “hundred” series (500, 600, 700, etc.) Retrofit Kts. Therefore certain sections and figures do not apply to the “ten” series (510, 610, 810, etc.) Retrofit Kits. Specifically, these are Sections 13 and 14, as well as Figures 3-2, 3-3, and 3-4.
2. *For All Kits Other Than 510 Basic.*
If testing the Breaker with Short Delay or Ground Fault functions, be sure to either plug in the Cell Harness Assembly or use the Zone Interlock Shorting Plug. Failure to do so may result in shorter than expected trip times.

3. *For 810 and 910 Kits Only.*

Without any power applied to the system (neither the 120 volt power supply nor the Aux. Power Module connected), plug the External Harness into the Cell Harness and check the impedance between COM 1 and COM 2. The impedance should be between 1 and 3 ohms. If the impedance is not within this range, trace the wiring and examine each connection to assure its integrity.

Confirm that the IMPACC communicating wiring is correct by following the procedures detailed in Section 7.4 of the Instructions for the Application of Digitrip RMS Retrofit Kits on Power Circuit Breakers. Note that for 810 and 910 Kits, the impedance between COM 1 and COM 2 should be between 1 and 3 ohms.

When the test is complete, disconnect the External Harness from the Cell Harness. Final External Harness Connection will be performed in Section 13.

For Kits Supplied with a Cell Harness Only.

Step 13: Mounting the Cell Harness

- A. The Cell Harness is to be mounted in the Breaker Cell. The connector end is to be mounted on the right front side of the Cell, in a location suitable for connection with the External Harness. The Terminal Blocks can be mounted anywhere space is available in the Cell as long as connection to the External Harness can be made.
- B. Route the Cell Harness wiring to keep it away from any moveable parts within the Cell Housing.

Step 14: Installing the Retrofitted Breaker in the Cell



WARNING

Do not leave the Breaker in an intermediate position in the Switchgear Cell. Always leave it in the CONNECTED, DISCONNECTED, or (Optional) TEST position. Failure to do so could lead to improper positioning of the Breaker and flashover, causing death, serious personal injury, and / or property damage.

NOTE: It is the responsibility of the Retrofitter to insure proper Breaker / Cell fit. When racking the Breaker into the Connected position, the Retrofitter **MUST FOLLOW BOTH** the manufacturer's instructions and the customer's safety standards and procedures for racking a Breaker into the Connected position.

- A. With the Breaker in the Open position and the springs discharged, slowly rack the Breaker into the Connected position, making sure there is no interference or binding. The Breaker should rack smoothly and without mechanical interference between any Breaker and Cell parts. The Retrofitter will feel some resistance when the primary fingers connect onto the stabs of the Cell. This is normal.

However, if any unusual resistance is detected that could be abnormal interference between the Breaker and Cell parts, stop immediately and move the Breaker out of the Connected position. Examine what is causing the interference and correct the situation.

**Digitrip Retrofit Kit Installation Components for the General Electric AK-50 Series Breakers:
AK-1-50 (Frameless); AK-2-50; AK-2A-50; AKT-2A-50; AKU-2A-50; AK-3-50; AK-3A-50; and AKT-3A-50**

Step	Description	Style No.	Qty.	Comment	
Step 3	Connector Parts	8258A95G04	1		
	Copper Connector		3		
	.375-16 × 1.50 Lng. Bolt Hex		12		
	.375 Flat Washer Stl.		12		
	.375 Lock Washer Stl.		12		
Step 4	Sensor		3	See Pick List	
	Sensor Assembly Parts	8258A95G14	1		
	Sensor Mounting Bracket		1		
	3-Point Terminal Block		3		
	.250-20 × .500 Lng. Hex Bolt		12		
	.250 Flat Washer Stl.		12		
	.250 Lock Washer Stl.		12		
	.138-32 × .500 Lng. T. C. Screw		6		
	.138 Lock Washer Stl.		6		
	Flexiform Grommet 6 Inch		3		
	Terminal #6 Insulating Ring		9		
	Sensor Mounting Parts	8258A95G15	1		
	.500-13 × 1.50 Lng. Hex Bolt		2		
	.500 Flat Washer Stl.		4		
	.500 Lock Washer Stl.		2		
	.500-13 Nut Hex Stl.		2		
	 Sensor Assembly Parts		8258A95G19	1	
		Sensor Mounting Bracket		1	
		3-Point Terminal Block		3	
		.250-20 × .500 Lng. Hex Bolt		12	
		.250 Flat Washer Stl.		12	
		.250 Lock Washer Stl.		12	
		.138-32 × .500 Lng. T. C. Screw		6	
		.138 Lock Washer Stl.		6	
		Flexiform Grommet 6 Inch		3	
		Terminal #6 Insulating Ring		9	
	Finger Cluster Mounting Parts	8258A95G18	1		
Glass Poly Support Plate		1			
.375-16 × 1.75 Lng. Hex Bolt		6			
.375 Flat Washer Stl.		6			
.375 Lock Washer Stl.		6			
.375-16 Drive Nut Stl.		6			
.164-16 × .500 Lng. T. C. Screw		2			
.164 Flat Washer Stl.		2			
Wire Clamp Nylon Small		2			
Wire Clamp Nylon Large		2			

**Digitrip Retrofit Kit Installation Components for the General Electric AK-50 Series Breakers:
AK-1-50 (Frameless); AK-2-50; AK-2A-50; AKT-2A-50; AKU-2A-50; AK-3-50; AK-3A-50; and AKT-3A-50 (Continued)**

Step	Description	Style No.	Qty.	Comment
Step 4 (cont.) 	Sensor Mounting Parts	8258A95G12	1	
	Mounting Bracket R. H.		3	
	Mounting Bracket L. H.		3	
	.250-20 x 2.75 Lng. Hex Bolt		6	
	.250 Flat Washer Stl.		12	
	.250 Lock Washer Stl.		6	
	.250-13 Nut Hex Stl.		6	
Step 5	Aux. CT Module	6506C45G	1	
	Aux. CT Module Mounting Parts	8258A95G16	1	
	.190-16 x .500 Lng. Thread Cutting Screw		4	
	.190 Flat Washer Stl.		4	
Step 6	Sensor Harness Mounting Parts	6503C83G01	1	
	Sensor Harness		1	
	DTA Extension Harness		1	
	Grommet		1	
	Wire Ties Nylon		6	
Step 7	DTA Assembly	8258A95G35	1	
	DTA Mounting Parts	8258A95G08	1	
	Trip Finger		1	
	DTA Reset Arm		1	
	.250-20 x .750 Lng. Carriage Bolt		1	
	.250 Flat Washer Stl.		1	
	.250 Lock Washer		1	
	.250-20 Nut Hex Stl.		1	
	.375-16 x 1.00 Lng. Hex Bolt		2	
	.375 Flat Washer		4	
	.375 Lock Washer		2	
	.375-16 Nut Hex Stl.		2	
Loc Tite® 242		1		
Step 8	Breaker Mounted CPT Kit	8259A91G05	1	} CPT Only
	CPT Mounting Parts	8258A95G20	1	
	CPT Mounting Bracket		1	
	Glass Poly Barrier		1	
	.250-20 x .625 Lng. Hex Bolt		2	
	.250 Flat Washer Stl.		4	
	.250 Lock Washer		2	
	.250-20 Nut Hex Stl.		2	
	.190-32 x .500 Lng. Screw Stl.		4	
	.190-32 x .625 Lng. Screw Nylon		2	
.190 Flat Washer Stl.		6		

**Digitrip Retrofit Kit Installation Components for the General Electric AK-50 Series Breakers:
AK-1-50 (Frameless); AK-2-50; AK-2A-50; AKT-2A-50; AKU-2A-50; AK-3-50; AK-3A-50; and AKT-3A-50 (Continued)**

Step	Description	Style No.	Qty.	Comment
Step 8 (cont.)	CPT Mounting Parts (continued)	8258A95G20	1	} CPT Only
	.190 Flat Washer Nylon		4	
	.190 Lock Washer Stl.		6	
	.190-32 Nut Hex Stl.		6	
Step 9	RMS/R Trip Unit		1	See Pick List
	Rating Plug		1	See Pick List
	Trip Unit Mounting Parts	8258A95G09	1	
	Trip Unit Mounting Bracket L. H.		1	
	Trip Unit Mounting Bracket R. H.		1	
	Glass Poly Barrier		1	
	Spacer Brass		4	
	.190-32 × 5.00 Lng. Screw Stl.		2	
	.190-32 × .500 Lng. Screw Stl.		2	
	.190-32 × .625 Lng. Screw Nylon		2	
	.190 Flat Washer Stl.		10	
	.190 Flat Washer Nylon		2	
	.190 Lock Washer Stl.		6	
	.190-32 Nut Hex Stl.		6	
	.250-20 × .750 Lng. Hex Bolt		2	
	.250 Flat Washer Stl.		4	
	.250 Lock Washer Stl.		2	
	.250-20 Nut Hex Stl.		2	
	Digitrip Nameplate		1	
	Aux. Switch Kit	8258A95G02	1	} Comm. Only
	Microswitch		1	
	Mounting Bracket		1	
	.138-32 × .375 Lng. Screw		1	
	.138-32 × 1.00 Lng. Screw		2	
	.138 Flat Washer Stl.		6	
	.138 Lock Washer Stl.		3	
	.138-32 Nut Hex Stl.		3	
PT Module Kit	6502C82G01	1		
PT Module Mounting Parts	8258A95G02	1		
.138-32 × .375 Lng. Screw		2		
.138 Flat Washer Stl.		2		
.138 Lock Washer Stl.		2		
PT Module Insulation		1		
Warning Nameplate		1		

**Digitrip Retrofit Kit Installation Components for the General Electric AK-50 Series Breakers:
AK-1-50 (Frameless); AK-2-50; AK-2A-50; AKT-2A-50; AKU-2A-50; AK-3-50; AK-3A-50; and AKT-3A-50 (Continued)**

Step	Description	Style No.	Qty.	Comment
Step 9 (cont.) 	Trip Unit "L" Bracket Mounting Parts	8258A11G01	1	
	Trip Unit "L" Mounting Bracket		1	
	.250-20 x .750 Lng. Hex Bolt		2	
	.250 Flat Washer Stl.		4	
	.250 Lock Washer Stl.		2	
	.250-20 Nut Hex Stl.		2	
Step 10	Aux. CT Harness	6502C84G02	1	
	External Harness	6502C83G__	1	
	Harness Mounting Parts	8258A95G10	1	
	.164-32 x .750 Lng. Screw		7	
	.164 Flat Washer Stl.		14	
	.164 Lock Washer Stl.		7	
	.164-32 Nut Hex Stl.		7	
	.375 Ring Terminal		3	Comm. Only
	Wire Ties Nylon Small		6	
Wire Ties Nylon Large		4		
Wire Clamp Nylon		7		
Step 12	Cell Harness	6503C57G__	1	Except 510 Basic

Note: Due to the wide vintage of Breakers and the multiple functions of the Retrofit Components, some excess hardware may be left when the Retrofit is complete.

Torque Values for General Mounting

Decimal Size (in)	Standard Size	Torque (in-lbs)	Torque (ft-lbs)
.112	4-40	10	0.8
.138	6-32	18	1.5
.164	8-32	36	3.0
.190	10-32	46	3.8
.250	1/4-20	100	8.3
.312	5/16-18	206	17.2
.375	3/8-16	356	29.7
.438	7/16-14	572	47.7
.500	1/2-13	856	71.3

Torque Values for Copper BUS Connectors

Decimal Size (in)	Standard Size	Torque (in-lbs)	Torque (ft-lbs)
.250	1/4-20	60	5
.312	5/16-18	144	12
.375	3/8-16	240	20
.500	1/2-13	600	50

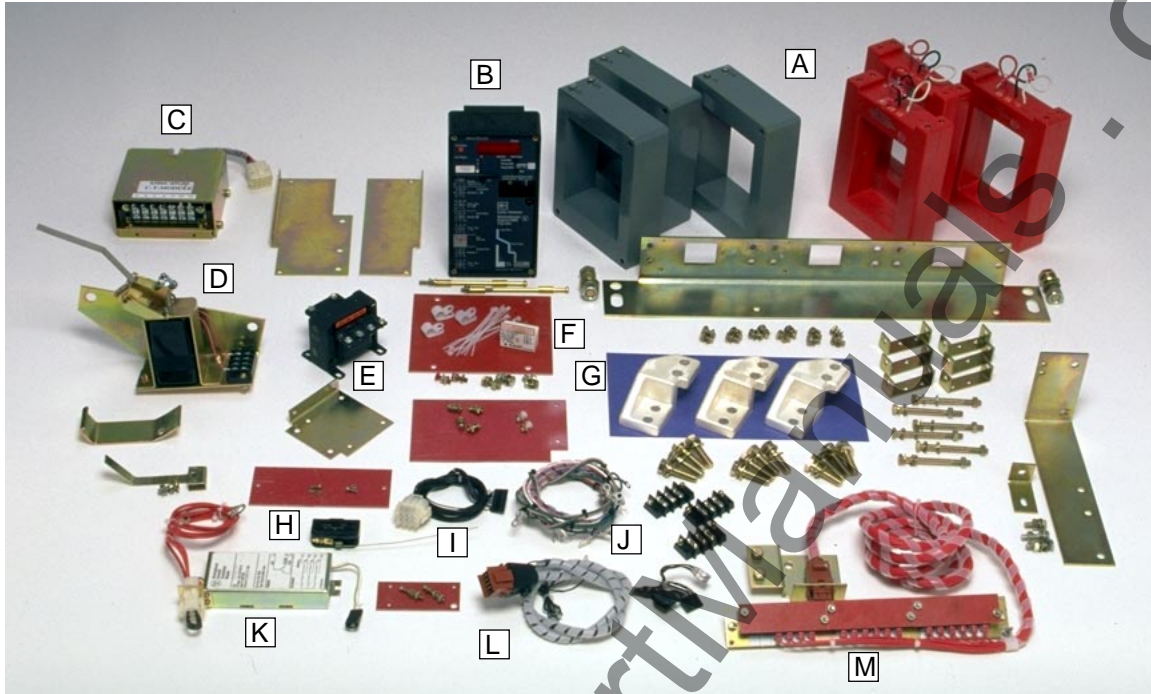

- | | |
|-------------------------------|---------------------------------|
| A. Sensors | H. Aux. Switch |
| B. Trip Unit | I. Aux. CT Harness |
| C. Aux. CT Module | J. Sensor Harness |
| D. Direct Trip Actuator (DTA) | K. PT Module |
| E. CPT Kit (Optional) | L. External Harness |
| F. Rating Plug | M. Cell Terminal Block Assembly |
| G. Copper Adaptors | |

NOTE: This family photo includes the components to complete the Retrofit for all Breakers covered in the IL. Therefore, all of the components pictured will not be included with all kits. Please note that the 0.75" Glass Poly Plate used in top fused Breaker Retrofits is not shown in this photo.

We wish to thank you for purchasing the Digitrip Retrofit System. Digitrip Retrofit Kits are designed and manufactured in America with pride. All the components are engineered to fit the existing Circuit Breaker with little or no modifications to the existing Breaker. However due to the wide variety and vintage of Breakers in use today, an occasional problem may arise. Please contact us with any questions, comments or concerns.

Phone: 1-800-937-5487 Fax. (724) 779-5899

The instructions for installation, testing, maintenance, or repair herein are provided for the use of the product in general commercial applications and may not be appropriate for use in nuclear applications. Additional instructions may be available upon specific request to replace, amend, or supplement these instructions to qualify them for use with the product in safety-related applications in a nuclear facility.

The information, recommendations, descriptions, and safety notations in this document are based on Cutler-Hammer's experience and judgement with respect to retrofitting of power breakers. This information should not be considered to be all inclusive or covering all contingencies. If further information is required, Cutler-Hammer should be consulted.

NO WARRANTIES, EXPRESSED OR IMPLIED, INCLUDING WARRANTIES OF FITNESS FOR A PARTICULAR PURPOSE OR MERCHANTABILITY, OR WARRANTIES ARISING FROM COURSE OF DEALING OR USAGE OF TRADE, ARE MADE REGARDING THE INFORMATION, RECOMMENDATIONS AND DESCRIPTIONS CONTAINED HEREIN. In no event will Cutler-Hammer be responsible to the user in contract, in tort (including negligence), strict liability or otherwise, for any special, indirect, incidental, or consequential damage or loss whatsoever, including but not limited to damage to or loss of use of equipment, plant or power system, cost of capital, loss of profits or revenues, cost of replacement power, additional expenses in the use of existing power facilities, or claims against the user by its customers resulting from the use of the information, recommendations, and descriptions contained herein.

Cutler-Hammer

130 Commonwealth Drive
Warrendale, PA 15086