



Cutler-Hammer

Instructions for Installation, Operation and Maintenance of Magnum DS, DSX and DSL Low Voltage Power Circuit Breakers

I.B. 2C12060H08 Supersedes I.B. 2C12060H07 dated April 2005
Effective May 2006



Double-wide Fixed



Standard Frame Fixed



Narrow Frame Fixed

www.ElectricalPartManuals.com

PURPOSE

This instruction manual is expressly intended to cover the installation, operation and maintenance of Magnum DS (MDS), DSX (MDSX) and Magnum DSL (MDSL) Power Circuit Breakers. These circuit breakers may be supplied as part of complete switchboard assemblies or as separate components. This manual applies only to the circuit breaker and (if drawout) it's mating cassette. The Magnum DSL circuit breaker can only be supplied as a drawout device. In the case of fixed versions of Magnum DS circuit breakers, certain sections of this manual, referring to such items as position interlocks and the drawout mechanism, will not apply.

Trip units associated with Magnum DS, DSX and DSL Power Circuit Breakers will be addressed in a general manner in this manual. Specific trip unit details and time-current characteristic curves are covered in separate documents specific to the trip units.

Magnum DS, DSX and DSL circuit breaker accessory items are discussed briefly in this manual. Field installation instructions for such items, however, are covered in individual instruction leaflets specific to the accessory. This information is also available from the Cutler-Hammer website at www.EatonElectrical.com

For application information, consult Cutler-Hammer or see applicable Product Guides, Technical Documents, Application Publications and/or Industry Standards.

SAFETY

All safety codes, safety standards and/or regulations must be strictly observed in the installation, operation and maintenance of this equipment.



WARNING

THE WARNINGS AND CAUTIONS INCLUDED AS PART OF THE PROCEDURAL STEPS IN THIS MANUAL ARE FOR PERSONNEL SAFETY AND PROTECTION OF EQUIPMENT FROM DAMAGE. AN EXAMPLE OF A TYPICAL WARNING LABEL HEADING IS SHOWN ABOVE TO FAMILIARIZE PERSONNEL WITH THE STYLE OF PRESENTATION. THIS WILL HELP TO INSURE THAT PERSONNEL ARE ALERT TO WARNINGS. IN ADDITION, CAUTIONS ARE ALL UPPER CASE AND BOLDFACE.

All possible contingencies which may arise during installation operation or maintenance, and all details and variations of this equipment do not purport to be covered by these instructions. If further information is desired by purchaser regarding his particular installation, operation or maintenance of particular equipment, contact the local Cutler-Hammer Inc. representative.

TABLE OF CONTENTS

SECTION 1: INTRODUCTION

PAGE

1-1 General Information.....1
 1-2 Safety Features.....2
 1-3 Safety Practices.....2
 1-4 Qualified Personnel.....3
 1-5 Other Publications and Documentation.....3

SECTION 2: RECEIVING, HANDLING AND INSTALLATION

2-1 General Information.....4
 2-2 Suggested Tools.....4
 2-3 Unpacking Circuit Breaker.....4
 2-3.1 Storing Circuit Breaker.....4
 2-4 Lifting Circuit Breaker.....5
 2-5 Circuit Breaker Inspection.....6
 2-6 Installing Drawout Circuit Breaker.....6
 2-6.1 Rejection Interlocks.....6
 2-6.2 Circuit Breaker Positioning.....7
 2-6.3 Levering Circuit Breaker.....9
 2-7 Fixed Circuit Breaker.....10
 2-8 Circuit Breaker Operation.....10

SECTION 3: CIRCUIT BREAKER DESCRIPTION AND OPERATION

3-1 Introduction.....11
 3-1.1 MDSL Application/Operation.....15
 3-2 Basic Circuit Breaker Assembly.....15
 3-3 Pole Units.....15
 3-3.1 Primary Moving Contacts.....16
 3-3.2 Primary Stationary Contacts.....16
 3-4 Operating Mechanism.....17
 3-4.1 Manual Operation.....17
 3-4.2 Electrical Operation.....18
 3-4.3 Anti-Pump Feature.....18
 3-5 Arc Chambers.....18
 3-5.1 Arc Chute.....18
 3-6 Electronic Tripping System.....19
 3-6.1 Microprocessor-based Trip Unit.....19
 3-6.2 Rating Plug.....21
 3-6.3 Current Sensors.....21
 3-6.4 Trip Actuator.....22
 3-6.5 Mechanical Trip Flag.....22
 3-6.6 Making Current Release.....22
 3-6.7 High Instantaneous Trip Option (Magnum DS Only).....22
 3-6.8 Voltage Taps.....23
 3-7 Secondary Contacts and Connection Diagrams.....23
 3-7.1 Connection Diagrams.....24

	PAGE
3-8 Accessory Devices	46
3-8.1 Plug-In Electrical Accessories	46
3-8.2 Internal Electrical Accessories	48
3-8.3 Mechanical Accessories	50
3-9 MDSL Limiters/Blown Limiter Indication	53
3-9.1 MDSL Current Limiters	53
3-9.2 Blown Limiter Sensing	53
 SECTION 4: DRAWOUT CIRCUIT BREAKER AND CASSETTE	
4-1 General	55
4-1.1 Drawout Cassette	55
4-2 Drawout Circuit Breaker Dimensions	57
4-3 Drawout Cassette Dimensions	57
 SECTION 5: FIXED CIRCUIT BREAKER	
5-1 General	59
5-2 Fixed Circuit Breaker Dimensions	59
 SECTION 6: INSPECTION AND MAINTENANCE	
6-1 General	60
6-2 General Cleaning Recommendations	60
6-3 When to Inspect	60
6-4 What to Inspect	61
6-4.1 Functional Field Testing	61
6-4.2 Arc Chute Inspection	62
6-4.3 Primary Contact Inspection	63
6-5 Circuit Breaker Modifications and Changes	64
6-5.1 Rating Plug Replacement	64
6-5.2 Current Sensor Replacement	65
6-5.3 Current Limiter Replacement (MDSL)	66
6-5.3.1 Replacing Type MA and MB Current Limiters	55
6-5.3.2 Replacing Type MD Current Limiters	66
6-5.3.3 Replacing Type MD Current Limiters on MDSL20 Breakers	66
 SECTION 7: TROUBLESHOOTING	
7-1 Introduction	67
 SECTION 8: RENEWAL PARTS	
8-1 General	70

FIGURES

Figure	Title	Page
1-1	Magnum DS Family of Low Voltage Power Fixed and Drawout Circuit Breakers (800-5000 Amperes) ..	1
1-2	Typical Magnum Nameplate	2
1-3 & 1-4	Sample Designation Examples	3
1-5	Typical Magnum DSL (MDSL) Drawout Breaker with Integral Current Limiters	3
2-1	Shipping Clamps for Drawout Circuit Breaker	4
2-2	Magnum DS Circuit Breaker with Lifting Yoke Attached	5
2-3	Rear View Showing Current Sensor Rating Through Viewing Window	6
2-4	One Side of Drawout MDS Circuit Breaker Properly Seated on Extension Rail	6
2-5	Cassette Rejection Interlock Pin Positioning/Installation	7
2-6	Remove Position	8
2-7	Disconnect Position	8
2-8	Test Position	8
2-9	Connect Position	9
2-10	Cassette Label Showing Disconnected, Test and Connected Position of Recessed Cover	9
2-11	Levering Position Indication	10
2-12	Typical Fixed Magnum DS Circuit Breaker	10
3-1	Typical MDS Drawout Circuit Breaker Features (Front and Rear Views)	11
3-2	Typical MDS Fixed Circuit Breaker Features (Front and Rear Views)	12
3-3	Typical MDSL Drawout Circuit Breaker Features (Front and Rear Views)	12
3-4	Typical Double-wide MDS Standard Frame Circuit Breaker Features (Front and Rear Views)	13
3-5	Typical Magnum DS Drawout Circuit Breaker Front Cover	14
3-6	Typical Magnum Construction (Right Side View)	15
3-7	Features of Magnum Moving Conductor Assembly	15
3-8	Narrow Frame (8-finger) Moving Conductor Assembly	16
3-9	Standard Frame (12-finger) Moving Conductor Assembly	16
3-10	Partial Cross-Sectional View (Shown in Closed Position)	16
3-11	Electrically Operated Drawout MDS Circuit Breaker with Front Cover Removed	17
3-12	Circuit Breaker Closing Springs Being Manually Charged	18
3-13	Electrical Motor Operator to Charge Closing Spring	18
3-14	Cross Section of Conductor and Arc Control System	19
3-15	Integral Arc Runner as Viewed From Top of Arc Chamber (Arc Chute Removed and Circuit Breaker Closed)	19
3-16	Magnum Arc Plate Assembly	19
3-17	Pictorial Diagram of Typical Current Sensing, Processing and Tripping System	20
3-18	Digitrip RMS 1150 Programmable Trip Unit Installed in Magnum DS Circuit Breaker	21
3-19	Hand Held Tester	21
3-20	Replaceable Current Sensors Shown with Bottom Adapters and Cover Plate Removed	22
3-21	Line Side Voltage Tap for 1150 Trip Unit	23
3-22	Top View Secondary Connectors	23
3-23	Secondary Connector Protective Hood	23
3-24	Cassette Mounted Secondary Wiring	24
3-25	AMP Secondary Wiring Removal Tool	24
3-26	Digitrip Connection Diagrams	25
thru		
3-46	Digitrip Connection Diagrams	45
3-34	Through-the-Window Electrical Accessories	46
3-35	Shunt Trip with Cutoff Switch	46
3-36	Shunt Trip Switch Installed	46
3-37	Spring Release with Optional Latch Check Switch	47
3-38	Undervoltage Release Device	47

Figure	Title	Page
3-39	Shunt Trip, Spring Release and Undervoltage Release Installed.....	47
3-40	Auxiliary Switch (2A/2B).....	48
3-41	Mechanical Trip Indicator with Associated Overcurrent Trip Switch.....	48
3-42	Motor Operator Kit.....	49
3-43	Motor Operator Installed in Narrow Frame Circuit Breaker.....	49
3-44	Cover Mounted Key Lock and Operations Counter.....	50
3-45	Cassette Mounted Key Lock.....	50
3-46	ON-OFF Pushbutton Lockable Cover Plate.....	50
3-47	Safety Shutters in Closed Position.....	51
3-48	Safety Shutters in Open Position.....	51
3-49	Cell Switch (Drawout Position Indicator) Unmounted.....	51
3-50	Cell Switches Mounted on Cassette.....	51
3-51	Door Escutcheon and Gasket.....	51
3-52	IP54 Waterproof Cover.....	52
3-53	Cassette-Mounted 2-Way Cable Interlock.....	52
3-54	Magnum DSL Circuit Breaker (Side View).....	53
3-55	Blow Fuse Indicator.....	53
4-1	Drawout Circuit Breaker in Cassette.....	55
4-2	Drawout Circuit Breaker with Automatic Primary Disconnects.....	55
4-3	Drawout Cassette Features.....	56
4-4	Narrow Frame Cassette (Horizontal Terminals).....	57
4-5	Standard Cassette (Vertical Terminals).....	57
4-6	Basic Cassette (Without Stabs).....	57
4-7	Universal Cassette, 4-Pole (Flat Terminal Pads).....	57
4-8	Typical MDSL Standard Cassette (Front View).....	58
4-9	Typical MDSL Standard Cassette (Rear View).....	58
5-1	Fixed Circuit Breaker with Available Vertical Adaptor.....	59
6-1	Top Rear View of Circuit Breaker with One Arc Chute Removed.....	62
6-2	Bottom View of Arc Chute.....	62
6-3	Primary Contacts with Circuit Breaker Open (Not Used for Contact Wear Inspection).....	63
6-4	Contact Inspection Area with Circuit Breaker Open.....	63
6-5	Use of Contact Wear Indicator with Circuit Breaker Closed.....	64
6-6	Trip Unit Rating Plug Location.....	64
6-7	Current Sensor Cover in Place Over Sensors.....	65
6-8	One Current Sensor Shown Removed and Disconnected.....	65
6-9	MD Limiters Shown Mounted in Extension.....	66

TABLES

Table	Title	Page
1.1	Magnum DS Ratings at 240, 480, 600 volts	2
1.2	Magnum DSL Ratings at 600 volts	3
2.1	Circuit Breaker Weights	5
2.2	Rejection Interlock Pin Locations	7
3.1	Magnum Digitrip Trip Units	20
3.2	Magnum DS Current Sensors and Matching Rating Plugs	22
3.3	Shunt Trip Ratings	46
3.4	Spring Release Ratings	47
3.5	Undervoltage Release	48
3.6	Auxiliary Switch, Overcurrent Trip Switch and Cell Switch Contact Ratings	48
3.7	Motor Operator	49
3.8	MDSL Integral Current Limiter Selection	54
6.1	Inspection Frequency	60
7.1	Circuit Breaker Troubleshooting Guide	67

SECTION 1: INTRODUCTION

1-1 GENERAL INFORMATION

The Magnum DS and DSX Power Circuit Breakers can be fixed or drawout air circuit breakers utilizing an electronic tripping system. The Magnum DSL circuit breaker utilizes the same tripping system, but is available only in the drawout configuration. MDSL and MDSX versions have current-limiting characteristics as indicated by the "Current Limiting" badge on the front covers. All breakers are designed for use in both switchboard and metal-enclosed switchgear assemblies having maximum voltages of 635 volts ac MDS type breakers, 600 volts ac for MDSL type breakers, and 480 volts ac for MDSX type breakers. Magnum DS circuit breakers are available in three physical frame sizes with continuous current ratings from 800 through 6000A, and interrupting capacities from 42 kA to 200 kA. The three MDS physical frame sizes have common height and depth dimensions, differing only in width (Figure 1-1). Magnum DSL circuit breakers are available in one frame size with continuous current ratings from 800 through 2000A and an interrupting capacity up to 200,000A (Figure 1-5). Circuit breaker nameplates provide complete rating information. All Magnum DS, Magnum DSX, and Magnum DSL circuit breakers are 100 percent rated, UL listed, and are built and tested in an ISO 9002 certified facility to applicable NEMA, ANSI, IEEE and UL standards (Tables 1.1 and 1.2, Figures 1-2, 1-3 and 1-4).

Magnum circuit breakers use a rigid frame housing of engineered thermoset composite resins which has high strength structural properties, excellent dielectric char-

acteristics and arc tracking resistance.

MDS, MDSX and MDSL drawout circuit breakers are a through-the-door design having three breaker positions with the compartment door closed (CONNECT, TEST, DISCONNECT) and one position out of its compartment on extension rails (REMOVE). The operating mechanism is a two-step stored energy mechanism, either manually or electrically operated.

When withdrawn on captive compartment cassette extension rails, MDS, MDSX and MDSL circuit breakers can be inspected, accessory items added, and minor maintenance performed. The inside of the compartment can also be inspected with the circuit breaker on its extension rails.

NOTICE

Please read and understand these instructions before attempting to unpack, install, operate or maintain this equipment. Study the breaker and its mechanism carefully before attempting to operate it on an energized circuit.



WARNING

MAGNUM CIRCUIT BREAKERS SHOULD NOT UNDER ANY CIRCUMSTANCES BE APPLIED OUTSIDE THEIR NAMEPLATE RATINGS. OPERATION OUTSIDE OF THESE RATINGS COULD RESULT IN DEATH, BODILY INJURY OR PROPERTY DAMAGE.

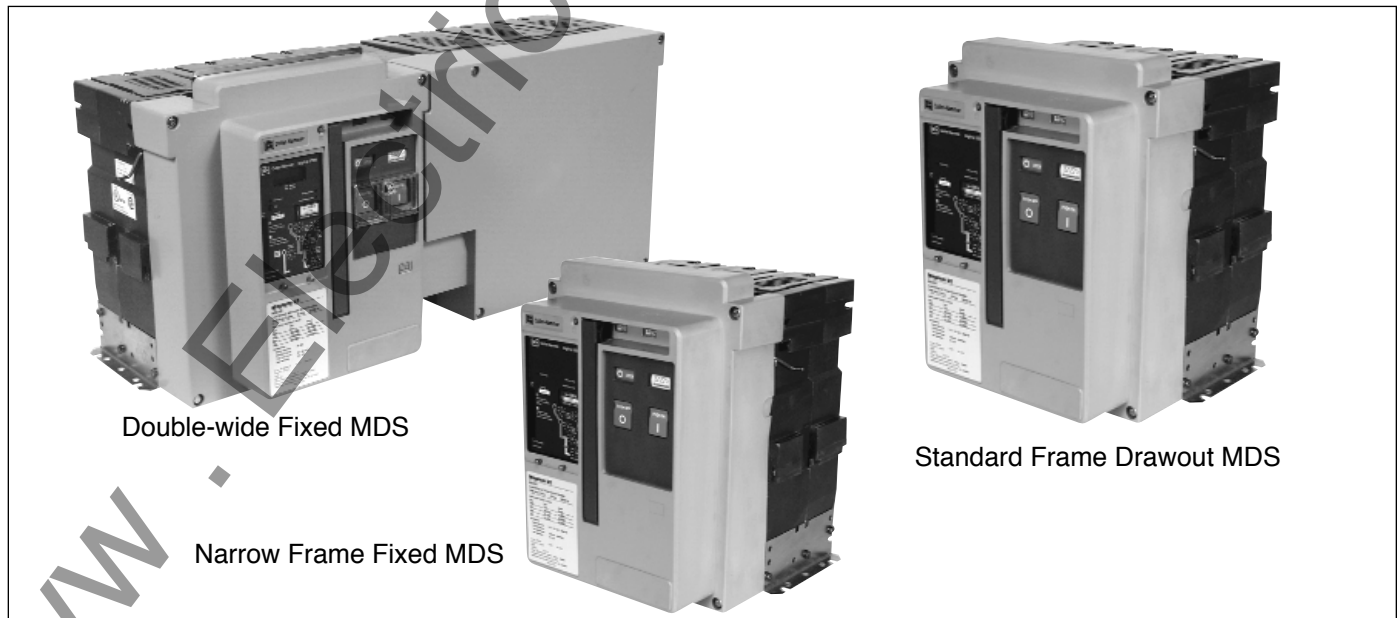

Figure 1-1 Family of Magnum DS (MDS) Low Voltage Power Fixed and Drawout Circuit Breakers (800-5000 Amperes)

1-2 SAFETY FEATURES

Magnum DS, DSX and DSL circuit breakers and associated drawout equipment are manufactured with built-in interlocks and safety related features. They are provided to reduce hazards to operating personnel and provide proper operating sequences.

Table 1.1 Magnum DS/DSX Ratings at 240, 480, 600 volts

Maximum Amperes	Breaker Designation	Interrupting Rating	Short Time Rating
800	MDN-408	42 kA	42 kA
	MDN-508	50 kA	50 kA
	MDN-608	65 kA	65 kA
	MDS-X08	200 kA (240v, 480v.)	30 kA
	MDS-408		42 kA
	MDS-508	50 kA	50 kA
	MDS-608	65 kA	65 kA
	MDS-808	85 kA	85 kA
	MDS-C08	100 kA	85 kA
	1200	MDN-412	42 kA
MDN-512		50 kA	50 kA
MDN-612		65 kA	65 kA
MDS-X12		200 kA (240v, 480v.)	30 kA
MDS-412			42 kA
MDS-512		50 kA	50 kA
MDS-612		65 kA	65 kA
MDS-812		85 kA	85 kA
MDS-C12		100 kA	85 kA
1600		MDN-416	42 kA
	MDN-516	50 kA	50 kA
	MDN-616	65 kA	65 kA
	MDS-X16	200 kA (240v, 480v.)	30 kA
	MDS-416		42 kA
	MDS-516	50 kA	50 kA
	MDS-616	65 kA	65 kA
	MDS-816	85 kA	85 kA
	MDS-C16	100 kA	85 kA
	2000	MDS-520	50 kA
MDS-X20		200 kA (240v, 480v.)	30 kA
MDS-620			65 kA
MDS-820		85 kA	85 kA
MDS-C20		100 kA	85 kA
2500	MDS-525	50 kA	50 kA
	MDS-X25	200 kA (240v, 480v.)	50 kA
	MDS-625		65 kA
	MDS-825	85 kA	85 kA
	MDS-C25	100 kA	85 kA
3000	MDS-630	65 kA	65 kA
	MDS-830	85 kA	85 kA
	MDS-C30	100 kA	85 kA
3200	MDS-X32, 3N	200 kA (240v, 480v.)	50 kA
	MDS-632		65 kA
	MDS-832	85 kA	85 kA
	MDS-C32	100 kA	85 kA
4000	MDS-X40	200 kA (240v, 480v.)	50 kA
	MDS-840, 84N		85 kA
	MDS-C40, C4N	100 kA	100 kA
5000	MDS-X50	200 kA (240v, 480v.)	50 kA
	MDS-850, 85N		85 kA
	MDS-C50, C5N	100 kA	100 kA
6000	MDS-860, 86N	85 kA	85 kA
	MDS-C60, C6N	100 kA	100 kA

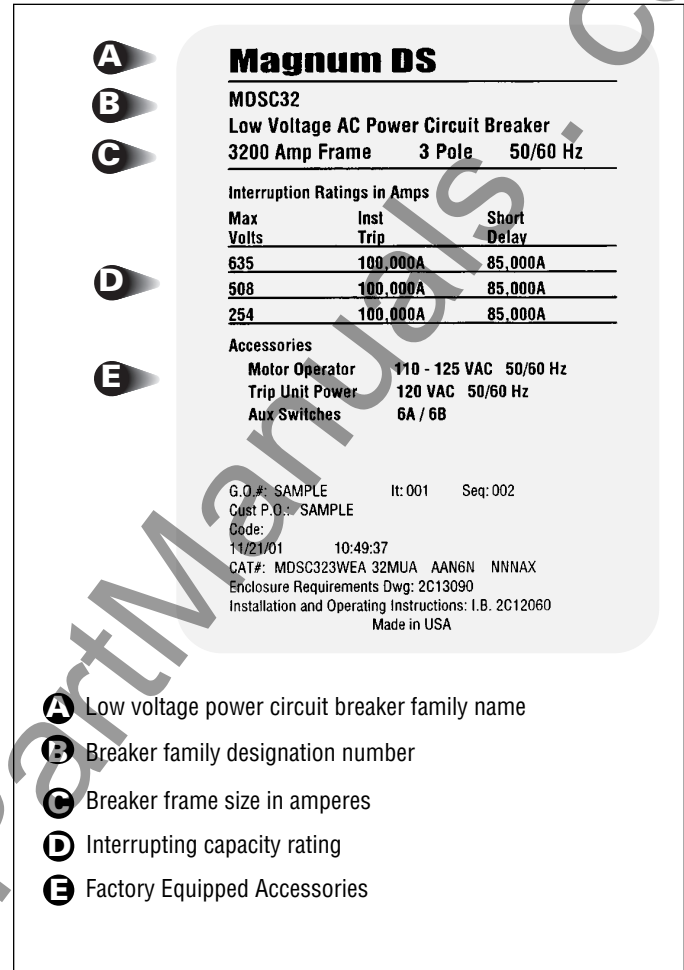

Figure 1-2 Typical Magnum DS (MDS) Nameplate



WARNING

MAGNUM DS, DSX AND DSL CIRCUIT BREAKERS ARE ROBUST AND ARE PROVIDED WITH SAFETY FEATURES. NEVERTHELESS, THE VOLTAGES, CURRENTS AND POWER LEVELS AVAILABLE IN AND AROUND THIS EQUIPMENT WHEN IT IS IN OPERATION ARE EXTREMELY DANGEROUS AND COULD BE FATAL. UNDER NO CIRCUMSTANCES SHOULD INTERLOCKS AND OTHER SAFETY FEATURES BE MADE INOPERATIVE, AS THIS MAY RESULT IN DEATH, BODILY INJURY OR PROPERTY DAMAGE.

1-3 SAFETY PRACTICES

To protect personnel associated with the installation, operation and maintenance of this equipment, the following practices must be followed:

1. Only qualified electrical personnel familiar with the equipment, its operation and the associated hazards should be permitted to work on the equipment. Additionally, only qualified personnel should be permitted to install or operate the equipment.
2. Always be certain that the primary and secondary circuits are de-energized or the circuit breaker is removed to a safe work location before attempting any maintenance.
3. For maximum safety, only insert a completely assembled breaker into an energized cell.
4. Always ensure that drawout circuit breakers are in one of their designed cell positions, such as Connect, Test, Disconnect or Remove. A circuit breaker permitted to remain in an intermediate position could result in control circuits being improperly connected resulting in electrical failures.

1-4 QUALIFIED PERSONNEL

For the purpose of operating and maintaining low voltage power circuit breakers, a person should not be considered qualified if the individual is not thoroughly trained in the operation of the circuit breaker and how it interfaces with the assembly in which it is used. In addition, the individual should have knowledge of the connected loads.

For the purpose of installing and inspecting circuit breakers and their associated assembly, a qualified person should also be trained with respect to the hazards inherent to working with electricity and the proper way to perform such work. The individual should be able to de-energize, clear and tag circuits in accordance with established safety practices.

1-5 OTHER PUBLICATIONS AND DOCUMENTATION

In addition to this instruction manual, other printed information and documentation is available and supplied as appropriate. This additional information can include, but not necessarily be limited to, an instruction manual for a specific electronic trip unit, instruction leaflets for accessory items, renewal parts information, necessary dimensional drawings and a Product (application) Guide. Specific reference documents associated with Magnum DS, DSX and DSL circuit breakers are listed in a separate document entitled *Engineering Data TD01301004E*

M D S	C 3 2
Circuit Breaker Type	Interrupting Capacity
<i>MDS - Standard and Double Wide Frames</i>	4 - 42,000 5 - 50,000 6 - 65,000
<i>MDN - Narrow Frame</i>	C - 100,000 E - 150,000 X - 200,000
	Frame Size
	08 - 800 Amps 12 - 1200 Amps 16 - 1600 Amps 20 - 2000 Amps 25 - 2500 Amps 30 - 3000 Amps 32 - 3200 Amps 40 - 4000 Amps 50 - 5000 Amps

Figure 1-3 Typical Magnum DS Designation Example

M D S L	0 8
Circuit Breaker Type	Interrupting Capacity
<i>MDSL - Standard Frame with Integral Current Limiters</i>	L - 200,000
	Frame Size
	08 - 800 Amps 12 - 1200 Amps 16 - 1600 Amps 20 - 2000 Amps

Figure 1-4 Typical Magnum DSL Designation Example

Table 1.2 Magnum DSL Ratings at 600 Volts and Below

Breaker Designation	Frame Size Amperes	Max. Interrupting Rating, RMS Sym. Amp., System Voltage 600 or Below
MDSL08	800	200,000
MDSL12	1200	200,000
MDSL16	1600	200,000
MDSL20	2000	200,000

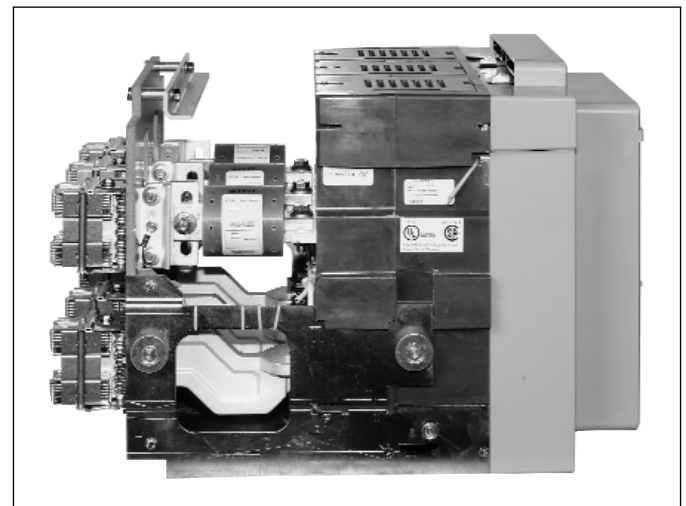

Figure 1-5 Typical Magnum DSL(MDSL) Drawout Circuit Breaker with Integral Current Limiters

SECTION 2: RECEIVING, HANDLING AND INSTALLATION

2-1 GENERAL INFORMATION

Magnum DS, DSX and DSL Power Circuit Breakers, when supplied as part of an assembly, may be shipped already installed in their respective breaker compartments. Receiving and handling of this equipment is addressed in an assembly instruction manual supplied with the assembled equipment. This instruction manual applies to only the circuit breakers.

2-2 SUGGESTED TOOLS

A large number of different tools are not required to properly install and maintain Magnum DS, DSX and DSL circuit breakers. The following tools are, however, suggested:

- Flat blade screwdriver
- Phillips head screwdriver
- 3/8" socket (ratchet) wrench
- 10 mm socket
- 17 mm socket
- Secondary wiring removal tool

2-3 UNPACKING CIRCUIT BREAKER

Before beginning to unpack new Magnum circuit breakers, read and understand these directions. Following the directions will ensure that no damage is caused.

Shipping containers should be inspected for obvious signs of rough handling and/or external damage incurred during the transportation phase. Record any observed damage for reporting to the transportation carrier and Cutler-Hammer, once the inspection is completed. All reports and claims should be as specific as possible and include the order number and other applicable nameplate information.

Every effort is made to ensure that Magnum circuit breakers arrive at their destination undamaged and ready for installation. Care should be exercised, however, to protect the breakers from impact at all times. Do not remove protective packaging until the breakers are ready for inspection, testing and/or installation.

When ready to inspect and install a Magnum circuit breaker, carefully remove the banding straps and lift off the cardboard box. Remove any additional packing material and internally packed documentation. The circuit breaker and/or cassette are mounted to a wooden shipping pallet.

On drawout circuit breakers shipped without a cassette, two shipping clamps hook into the breaker side plates and are held to the pallet with 4 lag screws (Figure 2-1). Remove the lag screws and clamps. Save the screws and clamps for future shipment of the breaker. On empty cassettes, remove the 4 or 5 lag screws and/or machine screws which pass through the floorpan of the cassette holding it to the wooden pallet. On drawout breakers shipped in a cassette, first remove the breaker from the cassette using the levering mechanism and drawout rails. After the breaker is removed the machine screws passing through the floorpan can be removed.

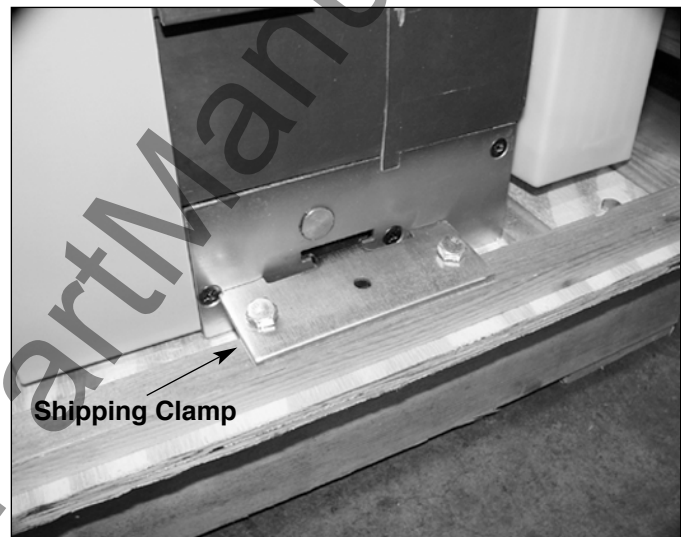

Figure 2-1 Shipping Clamps for Drawout Circuit Breaker

On fixed breakers, remove the lag screws passing through the mounting feet which hold the breaker to the pallet.

Circuit breakers are designed to be easily lifted from the wooden pallet using an appropriate lifting yoke and overhead or portable lifting device (Figure 2-2).

2-3.1 STORING CIRCUIT BREAKER

If it is necessary to store a circuit breaker before installation, do so in its original shipping container. Keep the circuit breaker in a clean dry place. Ensure there is ample air circulation and heat, if necessary, to prevent condensation. It is very important that the circuit breaker not be exposed to dirt or moisture.

NOTICE

A circuit breaker that has been stored for any length of time should be operated a minimum of five times before it is placed in service.

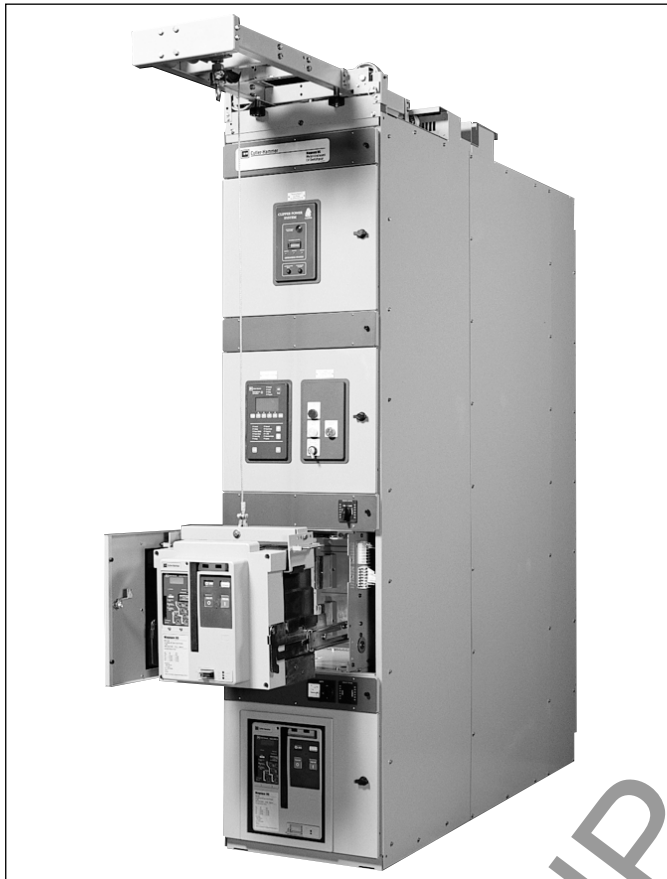

Figure 2-2 Magnum DS Circuit Breaker with Lifting Yoke Attached

2-4 LIFTING CIRCUIT BREAKER



CAUTION

DO NOT ATTEMPT TO LIFT CIRCUIT BREAKERS WITH ORDINARY CRANE HOOKS, ROPES, CHAINS OR OTHER SUCH DEVICES. FAILURE TO FOLLOW THIS CAUTION COULD RESULT IN DAMAGE TO VITAL PARTS SUCH AS ARC CHUTES, BARRIERS AND WIRING OR THE ENTIRE CIRCUIT BREAKER.

To closely examine, install or just become more familiar with the circuit breaker, carefully lift and place the circuit breaker on a solid work surface capable of handling the circuit breaker’s weight (Table 2.1) or on the captive drawout extension rails of the breaker compartment (Figure 2-2). This is accomplished by using the appropriate lifting yoke and lifter. The lifting yoke consists of two steel hooks specially shaped to hook under the integral molded lifting handles on both sides of the circuit breaker (Figure 3-1). Every effort should be made during lifting to minimize circuit breaker swing and tilt.

If the circuit breaker is to be lifted onto compartment extension rails, follow the instructions in paragraph 2-6 entitled “Installing Drawout Circuit Breaker.”

Table 2.1 Basic Circuit Breaker Weights

Breaker Model	Weights (lbs)					
	Fixed		Drawout		Universal Cassette	
	3P	4P	3P	4P	3P	4P
MDN-408	95	120	107	136	61	70
MDN-508						
MDN-608						
MDN-412						
MDN-512						
MDN-612						
MDN-416						
MDN-516						
MDN-616						
MDS-408	114	141	130	161	117	123
MDS-508	118	146	138	172	117	123
MDS-608						
MDS-412						
MDS-512						
MDS-612						
MDS-416						
MDS-516						
MDS-616						
MDS-520	128	160	155	194	117	123
MDS-620						
MDS-808						
MDS-812						
MDS-816						
MDS-820						
MDS-C08						
MDS-C12						
MDS-C16						
MDS-C20						
MDS-525	150	190	189	240	123	150
MDS-625						
MDS-630						
MDS-632						
MDS-825						
MDS-830						
MDS-832						
MDS-C25						
MDS-C30						
MDS-C32						
MDS-840, 84N	237	319	303	366	199	250
MDS-C40, C4N						
MDS-E40, E4N						
MDS-850, 85N	276	360	343	441	212	266
MDS-860, 86N						
MDS-C50, C5N						
MDS-C60, C6N						
MDS-E50, E5N						
MDS-E60, E6N						
MDSL08	NA	NA	180	NA	124	NA
MDSL12			200		124	
MDSL16			200		124	
MDSL20			215		131	
MDS-X08	169	NA	210	NA	140	NA
MDS-X12						
MDS-X16						
MDS-X20						
MDS-X25						
MDS-X32						
MDS-X40	279	NA	345	NA	210	NA
MDS-X50						

2-5 CIRCUIT BREAKER INSPECTION

All circuit breakers, once removed from their shipping containers, should be visually inspected for any obvious damage.

The current rating of the rating plug installed in the trip unit should match the current rating of the sensors mounted on the lower primary stabs of the circuit breaker. Check to make sure that this match exists. The rating plug rating can be viewed from the front of the circuit breaker (Figure 3-4). The sensor rating can be viewed through the viewing windows at the rear of the circuit breaker (Figure 2-3). Sensors and rating plugs can be easily changed as described in Section 6.

2-6 INSTALLING DRAWOUT CIRCUIT BREAKER

In structures equipped for drawout circuit breakers, a bolted-in cassette with movable extension rails supports the circuit breaker (Figures 2-2 and 2-4). The extension rails must first be pulled all the way out. Once the rails are fully extended, the circuit breaker can be carefully placed on the extension rails.



CAUTION

IT IS IMPORTANT TO TAKE GREAT CARE WHEN PLACING A DRAWOUT CIRCUIT BREAKER ON ITS EXTENSION RAILS. IF THE CIRCUIT BREAKER IS



Figure 2-3 Rear View Showing Current Sensor Rating Through Viewing Window

NOT PROPERLY SEATED ON THE EXTENSION RAILS, IT COULD FALL FROM THE RAILS CAUSING EQUIPMENT DAMAGE AND/OR BODILY INJURY.

Carefully lower the circuit breaker down onto the extension rails. Be certain that the circuit breaker's four molded rail supports are fully seated in the extension rail cutouts on both sides (Figure 2-4). **Do not remove the lifting yoke from the circuit breaker until it is properly seated on the rails.**

Once the circuit breaker is on the extension rails and the lifting yoke is removed, proceed with the rest of the circuit breaker installation.

2-6.1 REJECTION INTERLOCKS

Within any one physical frame size Magnum type drawout circuit breakers come in a variety of continuous current and interruption ratings, some of which are incompatible with others. Double wide circuit breakers also come with several phase sequence options which are also incompatible. To prevent the insertion of circuit breakers with (1) inadequate interrupting capability, (2) with physically incompatible primary disconnects or (3) with an incompatible phase sequence, rejection interlock key plates are provided on both the circuit breaker and cassette. The key plate on the circuit breaker is pre-assembled at the factory; but the cassette-side rejection plate and key pattern must be assembled and installed by the switchboard builder.

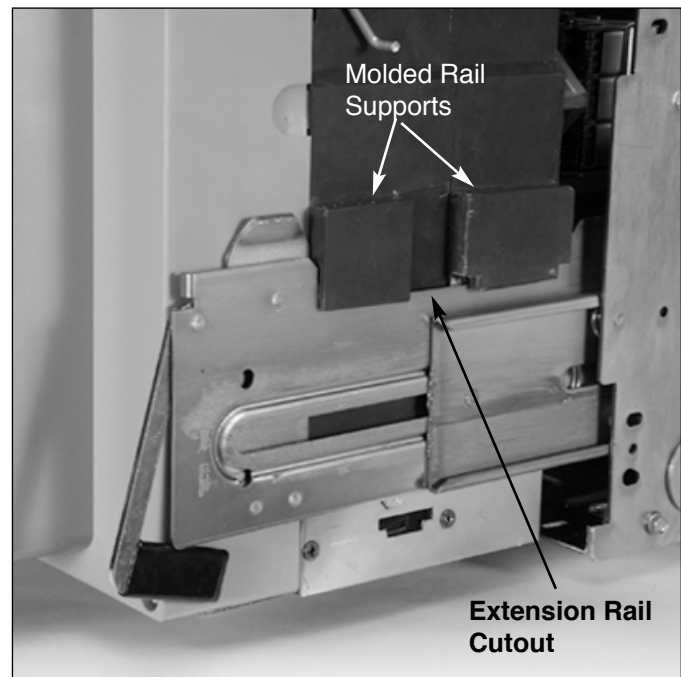

Figure 2-4 One Side of Drawout MDS/MDSX Circuit Breaker Properly Seated on Extension Rail



CAUTION

DO NOT DISABLE REJECTION INTERLOCKS. DOING SO AND USING A LOWER CAPACITY CIRCUIT BREAKER IN AN INCOMPATIBLE CASSETTE COULD RESULT IN AN ELECTRICAL FAULT WHICH COULD RESULT IN DEATH, BODILY INJURY AND/OR EQUIPMENT DAMAGE.

The rejection interlocks are steel pins in the floor of the circuit breaker cassette. As the circuit breaker is pushed into the structure, the mating pins on the bottom of the circuit breaker move past a set of corresponding pins in the cassette, if the circuit breaker and cassette are compatible. If the circuit breaker and the cassette are mismatched, the rejection pins will block the insertion of the circuit breaker into the cassette before the levering-in mechanism is engaged.

Before attempting to push the circuit breaker into the DISCONNECT position, compare the positioning of rejection interlock pins in the cassette in keeping with Table 2.2 and Figure 2-5 and the information supplied on the circuit breaker's nameplate. Proceed if the circuit breaker and cassette are compatible.

2-6.2 CIRCUIT BREAKER POSITIONING

Magnum DS, DSX and DSL drawout circuit breakers have four normal positions:

- REMOVE (Withdrawn) (Figure 2-6)
- DISCONNECT (Figure 2-7)
- TEST (Figure 2-8)
- CONNECT (Figure 2-9)

The REMOVE position is a position outside the compartment on the cassette's drawout rails where the circuit breaker is not engaged with the levering mecha

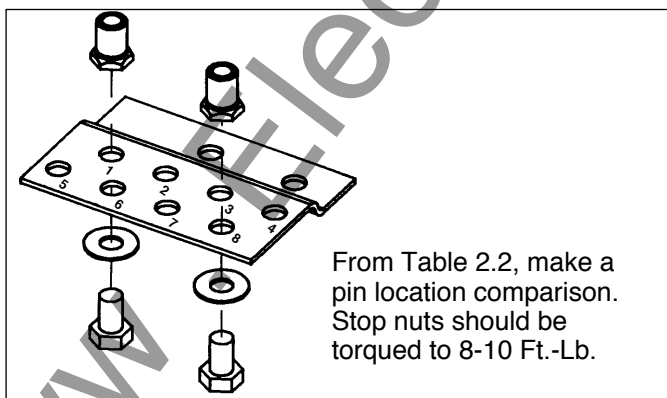

From Table 2.2, make a pin location comparison. Stop nuts should be torqued to 8-10 Ft.-Lb.

Figure 2-5 Cassette Rejection Interlock Pin Positioning/Installation

Table 2.2 Rejection Interlock Pin Locations

Cell For:	Pin Locations							
	1	2	3	4	5	6	7	8
MDN-408, 412, 416	X	X						
MDN-508, 512, 516	X	X			X			
MDN-608, 612, 616	X	X			X	X		
MDS-408, 412, 416	X	X						
MDS-508, 512, 516, 520	X	X			X			
MDS-608, 612, 616, 620	X	X			X	X		
MDS-808, 812, 816, 820	X	X			X	X	X	
MDS-C08, C12, C16, C20	X	X			X	X	X	X
MDS-525	X		X		X			
MDS-625, 630, 632	X		X		X	X		
MDS-825, 830, 832	X		X		X	X	X	
MDS-C25, C30, C32	X		X		X	X	X	X
MDS-840	X	X				X		
MDS-84N	X	X			X			
MDS-C40	X	X				X	X	
MDS-C4N	X	X			X		X	
MDS-E40	X	X				X	X	X
MDS-E4N	X	X			X		X	X
MDS-850, 860	X		X			X		
MDS-85N, 86N	X		X		X			
MDS-C50, C60	X		X			X	X	
MDS-C5N, C6N	X		X		X		X	
MDS-E50, E60	X		X			X	X	X
MDS-E5N, E6N	X		X		X		X	X
MDSL08		X					X	
MDSL12		X					X	
MDSL16		X					X	
MDSL20			X					X
MDS-X08	X		X-LG		X			
MDS-X12	X		X-LG		X			
MDS-X16	X		X-LG		X			
MDS-X20	X		X-LG		X			
MDS-X3N	X		X-LG			X		
MDS-X4N	X		X-LG			X		
MDS-X5N	X		X-LG			X		
MDS-X32	X		X-LG		X			
MDS-X40	X		X-LG		X			
MDS-X50	X		X-LG		X			

NOTE: X-LG IN TABLE 2.2 DENOTES LONG LENGTH STOP NUT 0.760 INCHES LONG

nism. The DISCONNECT, TEST, and CONNECT, positions are reached by means of the levering mechanism.

With the breaker solidly positioned on the cassette's extension rails and the levering-in mechanism in the DISCONNECT position, carefully and firmly push the circuit breaker into the compartment as far as it will go. The outer (recessed) portion of the circuit breaker face plate should align with the GREEN target line (labelled DISC) on the inside top left wall of the cassette (Figure 2-10).

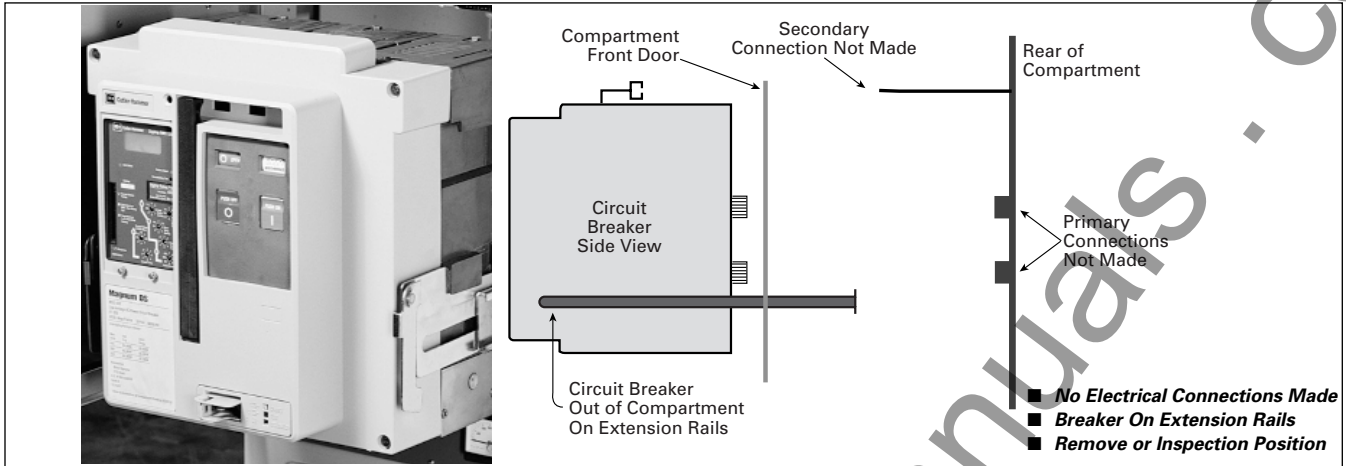

Figure 2-6 Remove Position

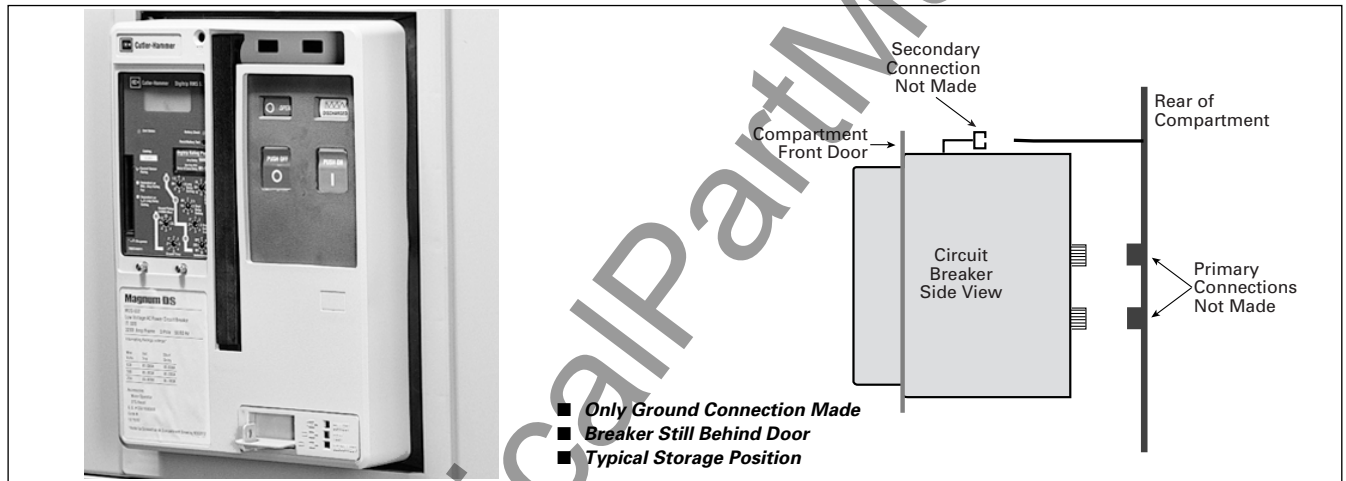

Figure 2-7 Disconnect Position

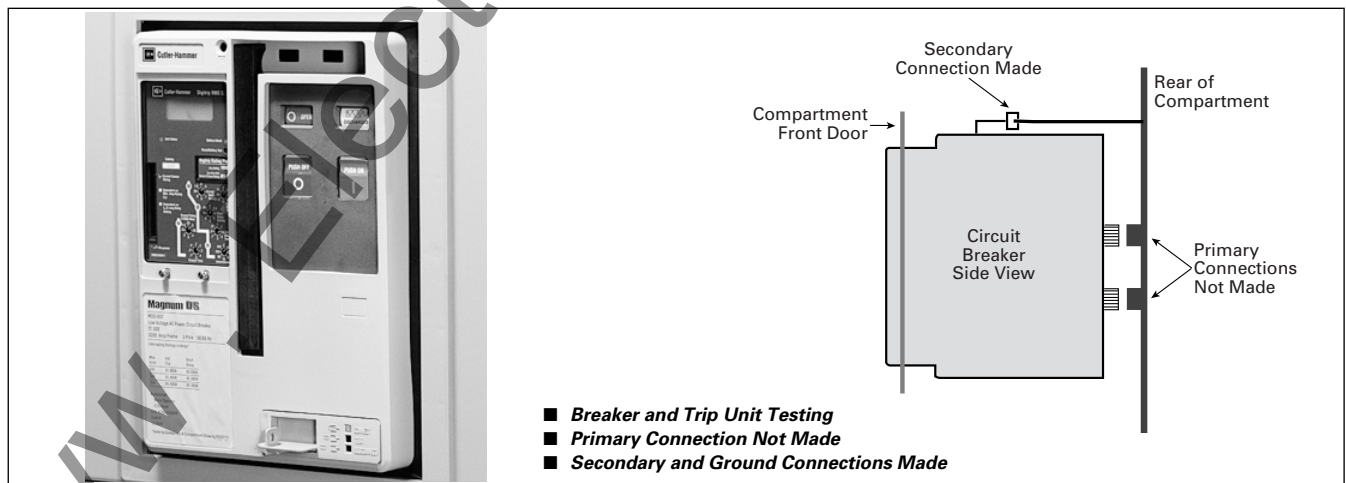

Figure 2-8 Test Position

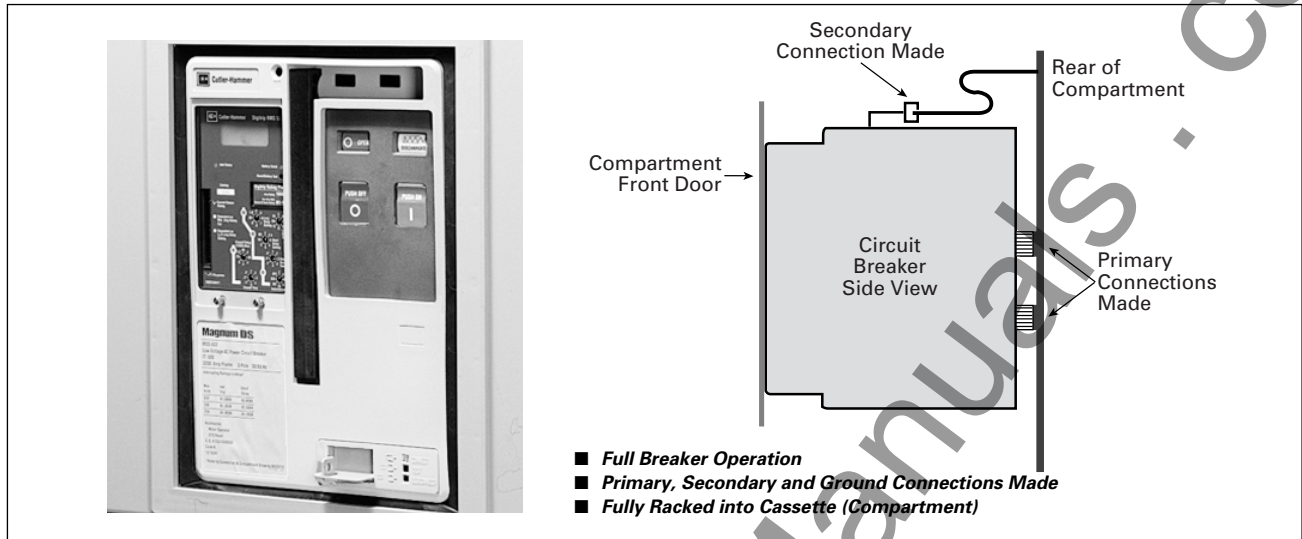

Figure 2-9 Connect Position



Figure 2-10 Cassette Label Showing Disconnected, Test and Connected Position of Recessed Cover

2-6.3 LEVERING CIRCUIT BREAKER



CAUTION

MAKE CERTAIN THAT THE CIRCUIT BREAKER IS FULLY INSERTED INTO ITS COMPARTMENT BEFORE ANY ATTEMPT IS MADE TO LEVER THE CIRCUIT BREAKER. ATTEMPTING TO LEVER THE CIRCUIT BREAKER IN BEFORE IT IS FULLY POSITIONED INSIDE ITS COMPARTMENT CAN RESULT IN DAMAGE TO BOTH THE CIRCUIT BREAKER AND THE COMPARTMENT.

The circuit breaker is now ready to be levered. With the circuit breaker OPEN, the levering device access door can be raised. The levering device is hand operated using a standard 3/8" square drive and ratchet, which is not provided (Figure 2-11). As long as the access door is raised, the circuit breaker is held trip free. Begin by rotating the levering-in screw to the full counterclockwise (DISCONNECT) position.

Close the compartment door and begin levering the breaker into its different positions using a clockwise ratcheting motion. When the circuit breaker is levered fully to the DISCONNECT or CONNECT position the levering shaft hits a hard stop; do not exceed 25 ft.lb. of torque or the levering mechanism may be damaged. **The circuit breaker can be levered with the compartment door open or closed, but it is advisable to close the door prior to levering.** The position of the circuit breaker within its compartment is indicated by color coded position indicators (Red = Connect, Yellow = Test, Green = Disconnect) (Figures 2-11 and 3-5). To remove the circuit breaker from its compartment, follow the procedure just described using a counterclockwise ratcheting motion.



Figure 2-11 Levering Position Indication

NOTICE

The circuit breaker mechanism is interlocked such that charged closing springs are automatically discharged if the circuit breaker is levered into or out of the cell. Discharge takes place between the DISCONNECT and TEST position.

2-7 FIXED CIRCUIT BREAKER

Magnum DS fixed type circuit breakers differ from the drawout version in that it has no levering device, primary disconnects and secondary disconnects (Figure 2-12). In addition, a fixed circuit breaker does not have a standard feature to hold the breaker in a trip-free position. To ensure the proper sequence of operation between two or more circuit breakers, an optional key interlock is mounted through the front panel (Figure 3-44).



WARNING

FAILURE TO COMPLY WITH INSTALLATION OF THE FIXED MOUNTED MDSX ARC HOOD ASSEMBLY COULD RESULT IN EQUIPMENT DAMAGE, BODILY INJURY OR EVEN DEATH.

The MDSX fixed mounted breaker is shipped with an included arc hood assembly. This assembly is **required to be installed** on the top of the breaker prior to the unit being placed in service.

Circuit breaker terminals have holes for making bolted horizontal primary bus connections. Adapters are avail



Figure 2-12 Typical Fixed Magnum DS Circuit Breaker

able for making vertical primary bus connections. Secondary connections can be made through standard terminal blocks or a special connector compatible with the drawout circuit breaker's type secondary connector. Both secondary connection devices are mounted at the top front of the circuit breaker.

The fixed circuit breaker frame has two mounting feet, one on each side, to permit the fixed circuit breaker to be securely mounted. Each mounting foot has two slotted mounting holes which are used to bolt the circuit breaker securely in place. Use either M10 or 3/8" bolts for this purpose. Refer to the dimensional drawings referred to in Section 5 (Fixed Circuit Breakers) for circuit breaker and bus stab dimensions.

NOTICE

Refer to the circuit breaker weights in Table 2.1 to ensure that the panel on which a fixed circuit breaker is to be mounted is capable of supporting the weight.

2-8 CIRCUIT BREAKER OPERATION

Circuit breakers should be operated manually and/or electrically before they are put into service. This can be done during the installation process or some later date prior to start-up. To check circuit breaker operation, follow the operational procedures outlined in Section 3 for both manually operated and electrically operated circuit breakers.

SECTION 3: CIRCUIT BREAKER DESCRIPTION AND OPERATION

3-1 INTRODUCTION

Magnum DS (MDS), DSX (MDSX) circuit breakers are available in both drawout and fixed mounting configurations (Figures 3-1 and 3-2). Magnum DSL (MDSL) circuit breakers with integral current limiters are available only in a drawout configuration (Figure 3-3). A majority of features are common to all configurations, and will be discussed in this section. The mounting features unique to the drawout and fixed configurations will be covered individually in Sections 4 and 5 respectively.

Controls and indicators for both drawout and fixed circuit breakers are functionally grouped on the front of the circuit breaker. The front escutcheon (faceplate) is common for all Magnum frame sizes up through 5000 amperes.

Double Wide DS and DSX frame circuit breakers utilize

six (or eight) sets of rear primary connections; these circuit breakers are available from the factory with several different phase sequences, distinguishable by the sixth character in the model number. The phase sequence is also labeled on the rear of the circuit breaker (Figure 3-4). For these DS and DSX drawout breakers, phase sequence labels are also supplied with the cassette and must be applied by the switchgear builder. Circuit breakers with different phase sequences are **not** interchangeable. DS and DSX drawout breakers with differing phase sequence are prevented from insertion into the cassette by properly assembled rejection key plates (see section 2-6.2).

The Magnum DSL (MDSL) drawout circuit breaker is available only in a 3-pole single wide standard configuration. The MDSL is a coordinated combination of a standard Magnum DS circuit breaker and series connected current limiters. The primary purpose of the current limiters is to extend the interrupting rating of the MDS circuit breaker up to 200,000 amperes.

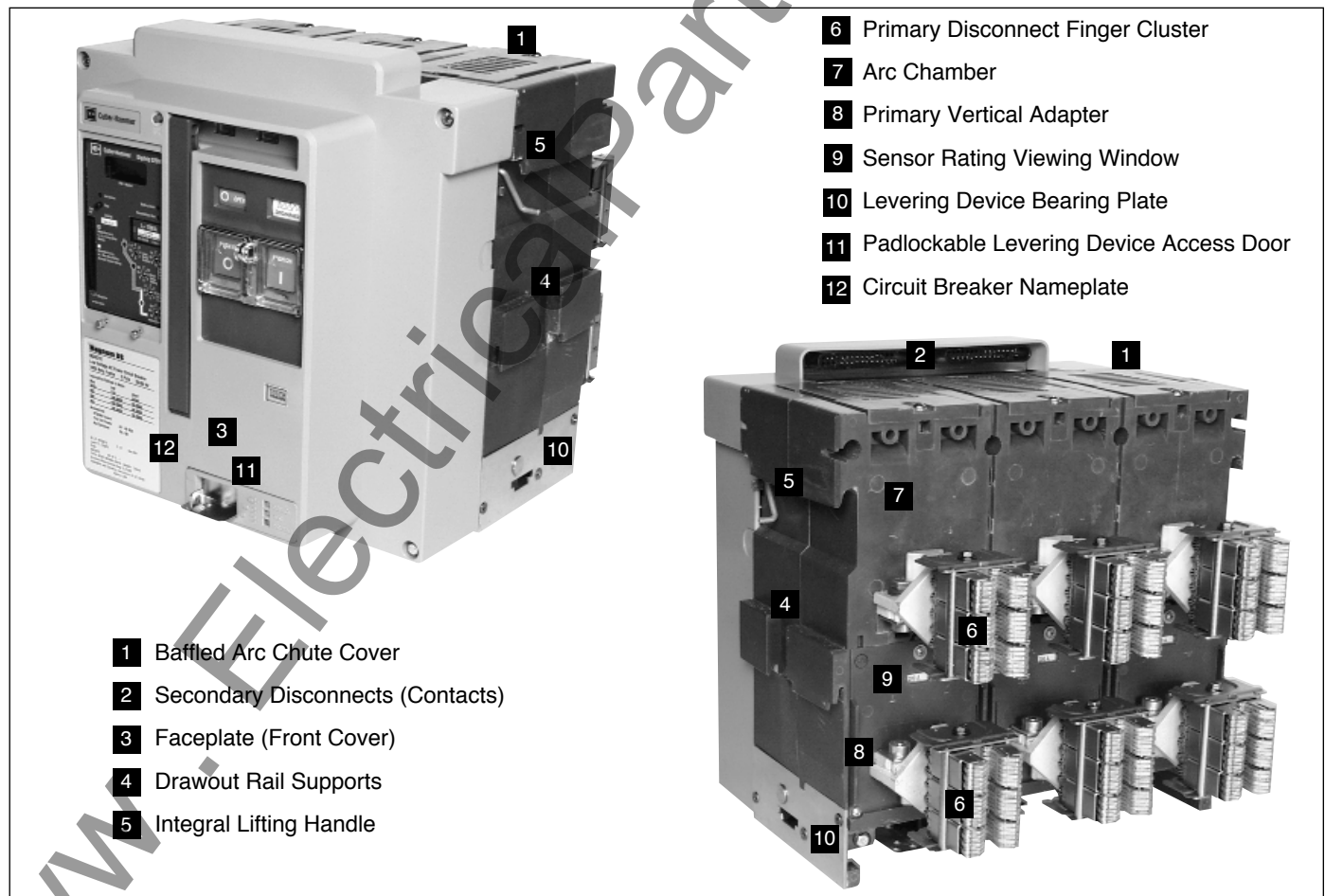

Figure 3-1 Typical MDS /MDSX Drawout Circuit Breaker Features (Front and Rear Views)

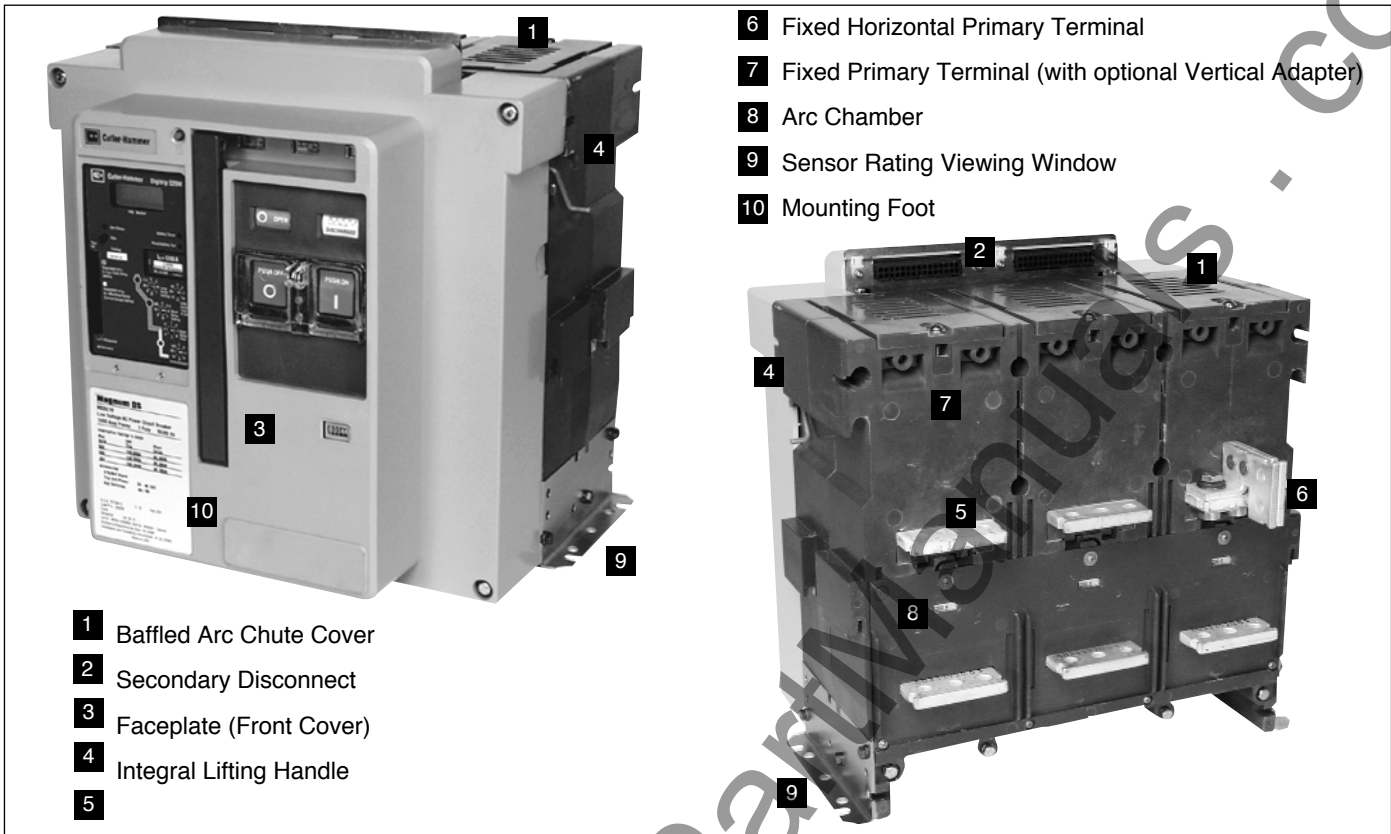

Figure 3-2 Typical MDS/MDSX Fixed Circuit Breaker Features (Front and Rear Views) (MDSX shown without required arc hood)

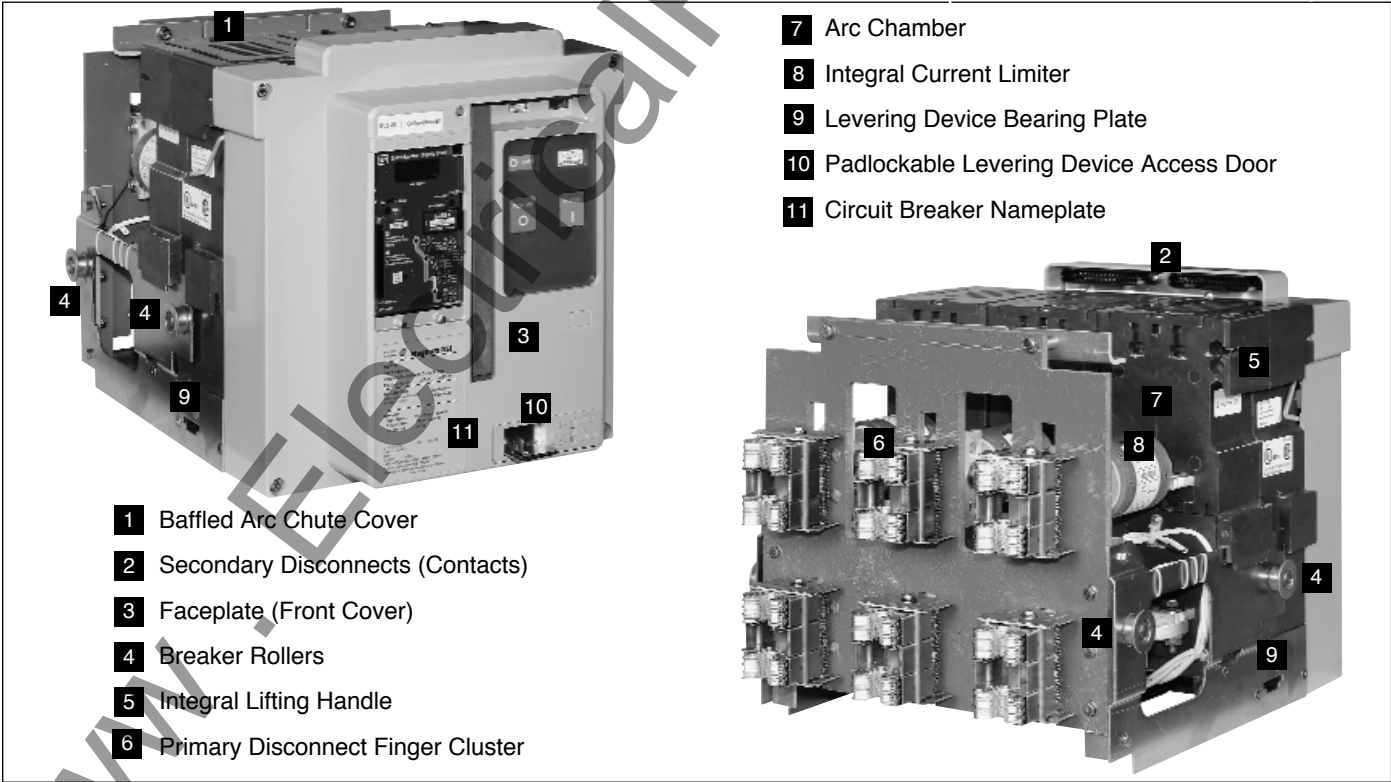

Figure 3-3 Typical MDSL Drawout Circuit Breaker Features (Front and Rear Views)



- 1** Baffled Arc Chute Cover
- 2** Secondary Contact Connector
- 3** Faceplate (Front Cover)
- 4** Integral Lifting Handle
- 5** Fixed Vertical Primary Terminals with Optional Vertical Adaptor
- 6** Arc Chamber
- 7** Mounting Foot
- 8** Circuit Breaker Nameplate
- 9** Phase Identification Labels

Figure 3-4 Typical Double-wide MDS/MDSX Standard Frame Fixed Circuit Breaker Features (Front and Rear Views) (MDSX shown without required arc hood)

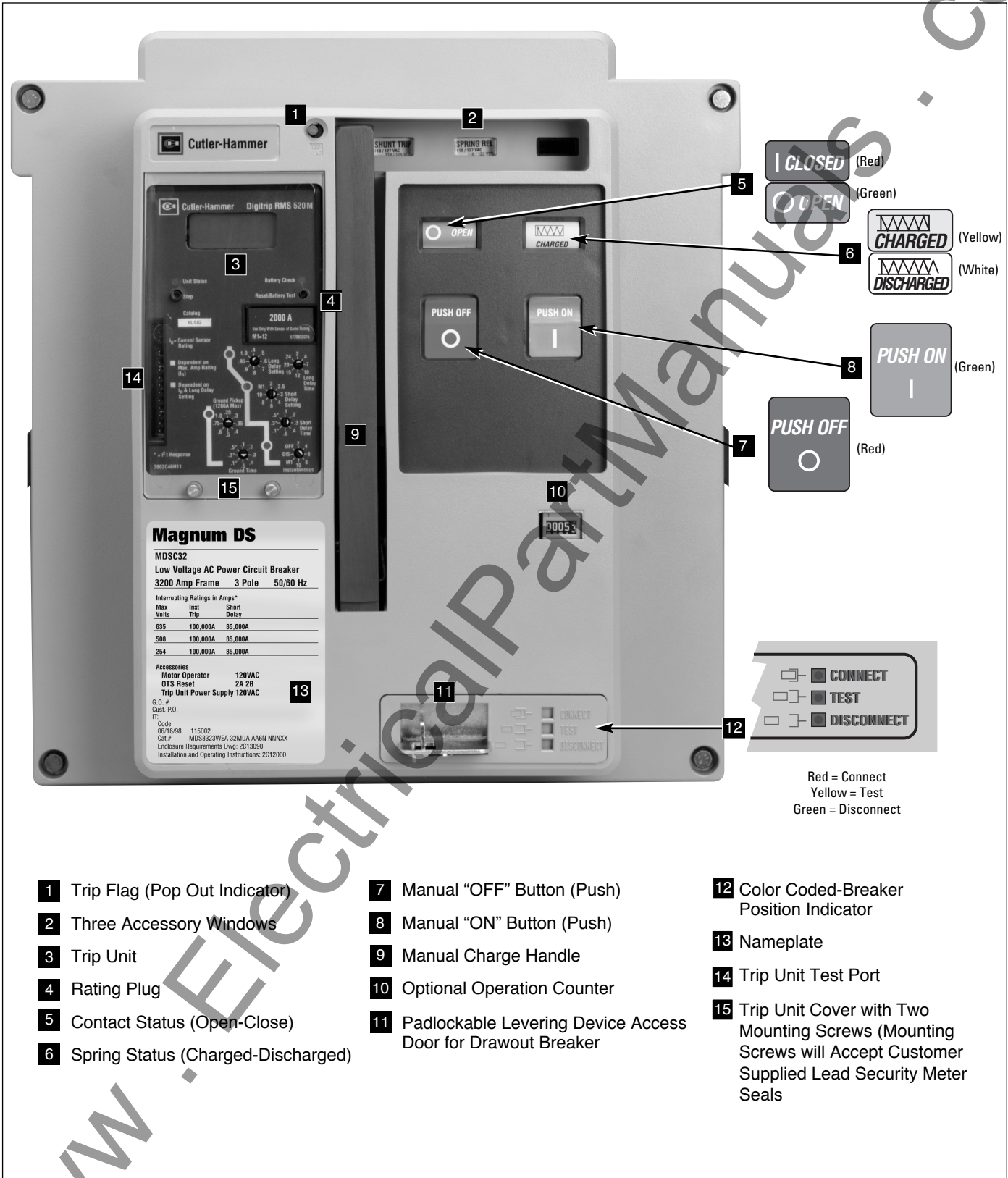

Figure 3-5 Typical Magnum DS/DSX Drawout Circuit Breaker Front Cover

3-1.1 MDSL APPLICATION/OPERATION

MDSL circuit breakers are intended for applications requiring the overload protection and switching functions of air circuit breakers on systems whose available fault currents (1) exceed the interrupting ratings of the circuit breakers alone and/or (2) exceed the withstand and interrupting ratings of downstream circuit components.

The 800 through 2000 amp frame MDSL circuit breakers have integrally mounted limiters on the drawout breaker element. On overloads and faults within the circuit breaker interrupting rating, the circuit breaker protects the limiters. On higher fault currents exceeding the circuit breaker rating, the limiters protect the circuit breaker.

Interlock arrangements trip the circuit breaker whenever any limiter blows. The circuit breaker cannot be reclosed on a live source unless there are three unblown limiters on the circuit. The blown fuse indicator, located on the front of the circuit breaker, provides a visual indication when a current limiter in any phase has interrupted a short circuit. In addition, a blown limiter sensing circuit insures that a circuit breaker will be tripped when any current limiter has blown, preventing single phasing.

The MDSL circuit breaker must be completely withdrawn from its compartment onto the compartment's extension rails, thus assuring complete isolation, before the integral current limiters are accessible.

Additional information concerning current limiter ratings, limiter replacement and blown fuse operation is provided later in this chapter.

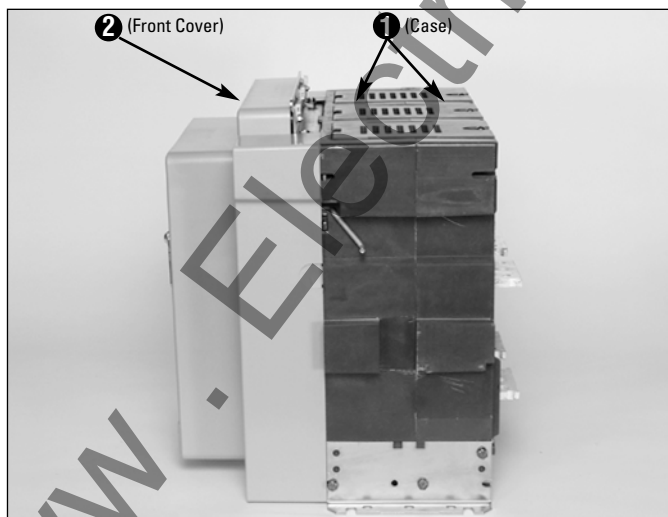

Figure 3-6 Typical Magnum Construction (Right Side View)

3-2 BASIC CIRCUIT BREAKER ASSEMBLY

All Magnum circuit breakers use a rigid frame housing construction of engineered thermoset composite resins. This construction provides high strength structural properties, excellent dielectric characteristics and resistance to arc tracking.

The 3-piece construction approach provides support while isolating and insulating power conductors (Figure 3-6):

- ❶ A 2-piece engineered thermoset composite resin case encloses current paths and arc chambers. The chambers act to channel arc gases up and out of the circuit breaker during interruption.
- ❷ The operating mechanism sits on the front of the case and is electrically isolated and insulated from current contact structures. It is covered by an insulating front cover.

3-3 POLE UNITS

A current carrying pole unit is individually enclosed and rigidly supported by the case. The individual chambers provide for pole unit isolation and insulation from one another. Each pole unit has one primary contact assembly, which consists of a moving portion and a fixed portion. The exact design configuration depends upon the breaker's frame size. Circuit breakers with frame sizes of 4000 amperes and higher use two pole units and arc chute assemblies connected mechanically and electrically in parallel to form one phase.

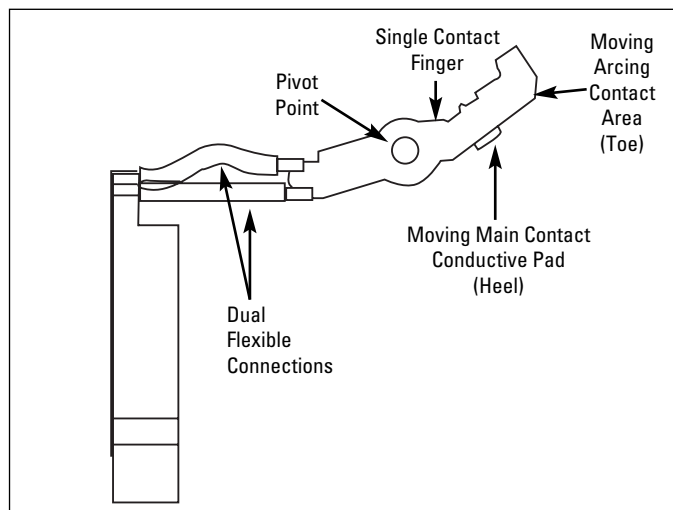

Figure 3-7 Features of Magnum Moving Conductor Assembly

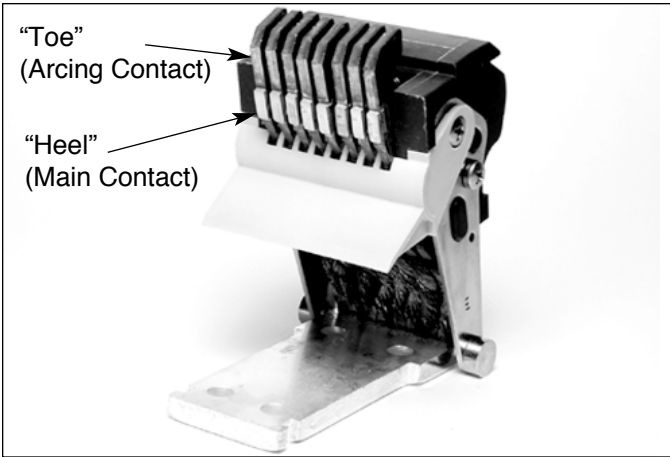

Figure 3-8 Narrow Frame (8-finger) Moving Conductor Assembly

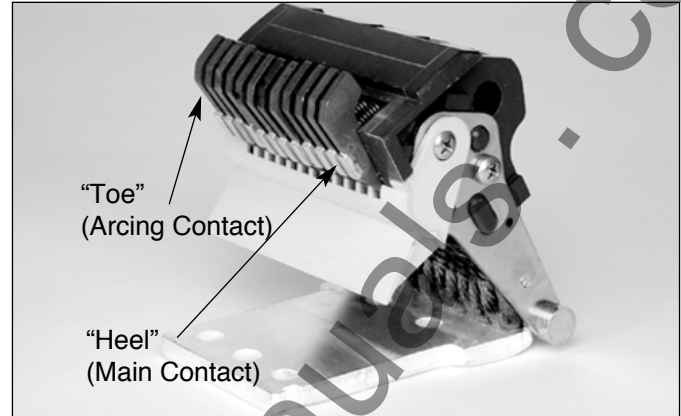

Figure 3-9 Standard Frame DS (12-finger) Moving Conductor Assembly

3-3.1 PRIMARY MOVING CONTACTS

Depending upon the frame size, each primary moving contact assembly is comprised of multiple individual copper contact fingers connected to the load conductor through flexible braided connectors (Figure 3-8). Two flexible connectors are used to connect each finger to the load conductor. The number of fingers used depends upon the circuit breaker's continuous and short-circuit current ratings (Figures 3-8 and 3-9). On some ratings fingers are removed and replaced with spacers.

The single contact finger performs both the main and arcing contact functions on different parts of the same finger (Figure 3-7). A highly conductive alloy pad is part of the contact finger and functions as the moving main contact, and is called the "Heel." The tip of the same contact finger functions as the moving arcing contact, and is called the "Toe."

In addition to the contact finger information given above, DSX (MDSX) utilize an inner and outer carriage design to facilitate a fast opening blow open contact structure (Figure 3-9a). The contact fingers mounted in the inner contact carrier can move independently from both the outer carrier and the opening mechanism in the breaker. This independence is the core design feature of its fast opening blow open contact structure.

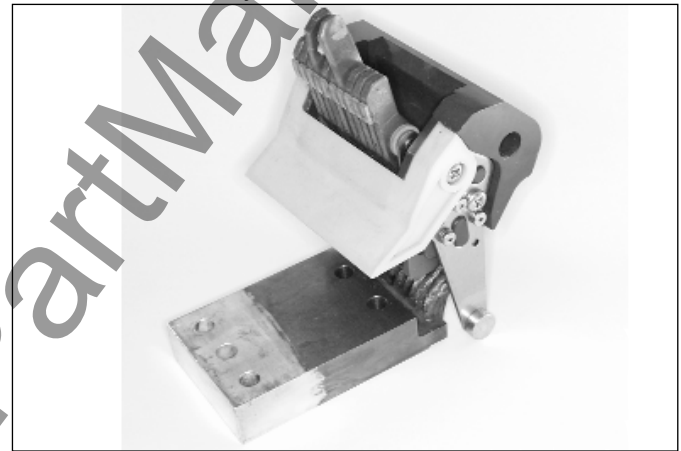

Figure 3-9a MDSX Moving Contact Assembly

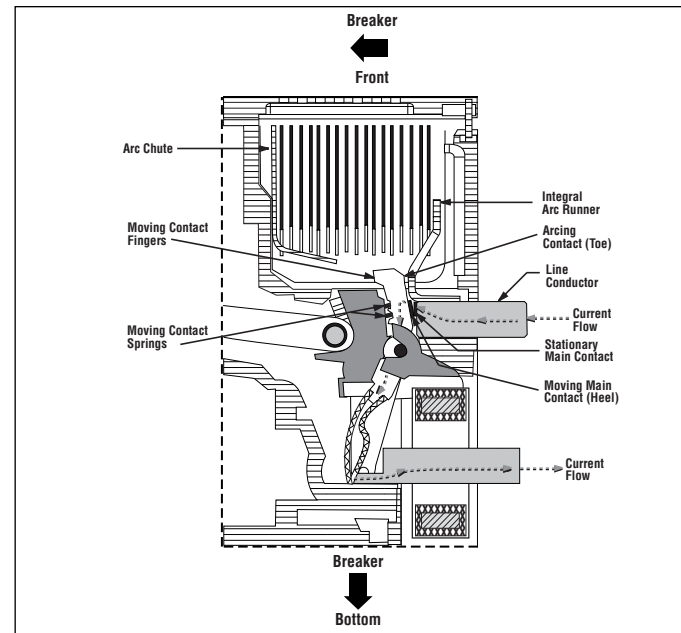

Figure 3-10 General Partial Cross-Sectional View (Shown in Closed Position) (not specific to any family/frame)

3-3.2 PRIMARY STATIONARY CONTACTS

The primary stationary contact is a combination of two items (Figure 3-10). One is a conductive pad mounted on the line conductor which functions as the stationary main contact. The other is an arc runner, also connected to the line conductor. The integral arc runner serves a dual purpose:

- Fixed arcing contact
- Part of the arc chute

3-4 OPERATING MECHANISM

The Magnum DS/DSX/DSL operating mechanism is based on the proven cam and spring design of the DSII power circuit breaker. It is easily accessed by removing four cover screws and the front cover (Figure 3-11). The mechanism is a two-step stored energy mechanism. Potential energy is stored to close the circuit breaker. Sufficient energy to open the circuit breaker remains available after a closing operation.

3-4.1 MANUAL OPERATION

On manually operated circuit breakers, the closing spring can only be charged manually. To manually charge the spring, insert one finger in the recess behind the charging handle and pull out. This permits a gloved hand to grasp the handle and begin charging (Figure 3-12). It takes from 5 to 7 downward strokes on the charging handle to

complete the manual charging process. It is possible to manually recharge the spring immediately after closing the circuit breaker and before it has been tripped open.

Standard manually operated circuit breakers are closed and opened by hand using the Manual "ON" and Manual "OFF" buttons respectively located on the front of the circuit breaker (Figure 3-5). Performing either operation is accomplished by pressing and releasing the appropriate button. Access to these pushbuttons can be limited by the use of an optional, padlockable cover. In addition, complete access to the "ON" button can be prevented with an optional prevent close cover. The status of the springs and the primary contacts are always indicated in an indicator window just above the pushbuttons.

Electrically operated optional devices are available to automatically close or trip a manually operated circuit breaker. An electrical spring release is available to close a manually operated circuit breaker. Two optional devices, a shunt trip and an undervoltage release, are available to automatically trip (open) a manually operated circuit breaker. All of these UL listed optional devices can be installed easily in the field. For more details on these devices, refer to paragraph 3-8 in this manual.

An electrical operator which is used to charge the closing spring automatically can be added to a manually operated circuit breaker in the field (Figure 3-13). Manually operated circuit breakers are pre-wired to accept this addition.

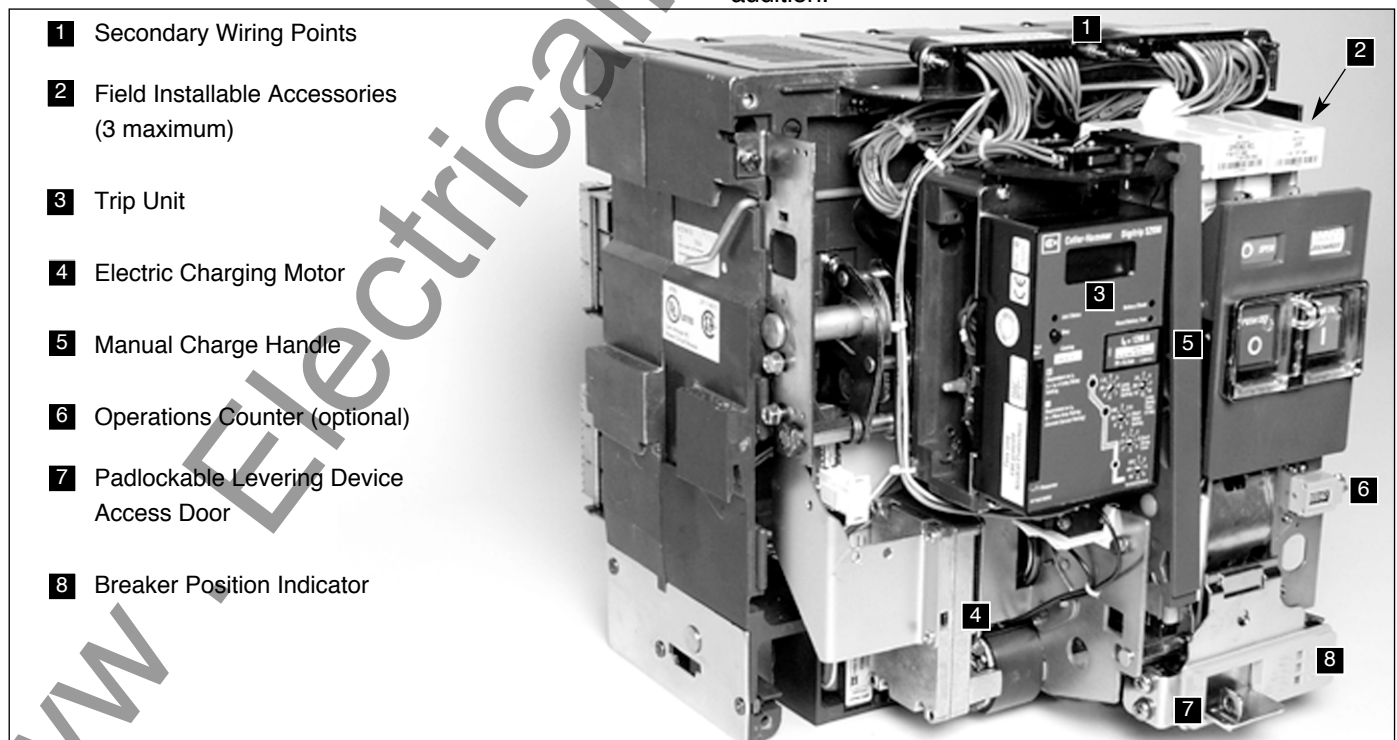

Figure 3-11 Typical Electrically Operated Drawout MDS/MDSX Circuit Breaker with Front Cover Removed



Figure 3-12 Circuit Breaker Closing Springs Being Manually Charged

3-4.2 ELECTRICAL OPERATION

For electrically operated circuit breakers, the springs are normally charged through the use of an electrical operator (Figure 3-13). The springs can, however, be charged manually as just described in the previous paragraph (Figure 3-12).

Like the manually operated circuit breaker in the previous paragraph, electrically operated circuit breakers can also be manually closed and opened through the use of the front mounted Manual "ON" and Manual "OFF" buttons.

An electrically operated circuit breaker from the factory is also equipped as standard with a spring release to close the circuit breaker electrically. An optional shunt trip and undervoltage release are also available to trip (open) an electrically operated circuit breaker. Refer to paragraph 3-8 for more details on both standard and optional devices.

3-4.3 ANTI-PUMP FEATURE

The Magnum circuit breaker has both mechanical and electrical anti-pump features. If the circuit breaker is closed on a fault condition (and trips open while the CLOSE signal is maintained), using either the mechanical pushbutton or the spring release, it will not make subsequent attempt to close until the close command is removed and reapplied. Note that if the close signal is applied prematurely (before the breaker is completely charged and latched), the close command will be ignored until it is removed and reapplied. For electrical

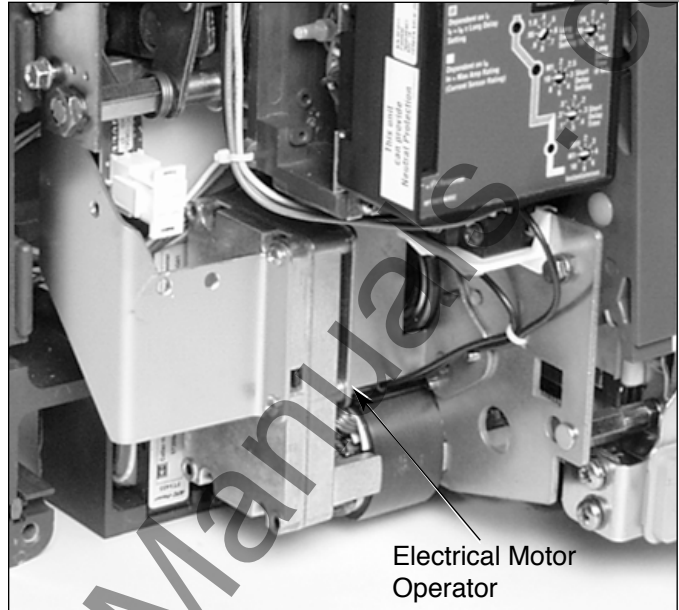

Figure 3-13 Electrical Motor Operator to Charge Closing Spring

closing, a Latch Check Switch (LCS) option is available (see paragraph 3-8.1) which will block the application of the electrical close command until the breaker is ready to close.

3-5 ARC CHAMBERS

The Magnum DS/DSX/DSL circuit breakers utilizes arc chambers to insulate and isolate individual poles from one another, from the rest of the circuit breaker, and from operating personnel (Figure 3-1). Arc chambers are molded and integral parts of the circuit breaker frame. Enclosed within each arc chamber is an arc chute which mounts over each set of primary contacts.

After the main contacts part, any remaining current is driven to the arcing contacts (Figure 3-14). Magnetic action draws the arc to the arc chute. As the arcing contacts separate, the moving arcing contacts discharge into the arc chute plates while the integral arc runner also helps to draw the arc into the arc chute (Figure 3-15).

3-5.1 ARC CHUTE

The Magnum DS/DSX/DSL arc chutes mount down over the arcing contact. V-shaped arc chute plates attract the arc and interrupt it. The top arc plate, which is a part of the arc chute itself, also helps to attract the arc away from the moving arcing contact and up into the arc chute's V-shaped plates (Figure 3-16 and 3-16a).

Arc chute components are assembled in an insulating jacket which is removable from the top of the circuit breaker, as previously described in paragraph 2-4. Each arc chute has a baffled top cover.

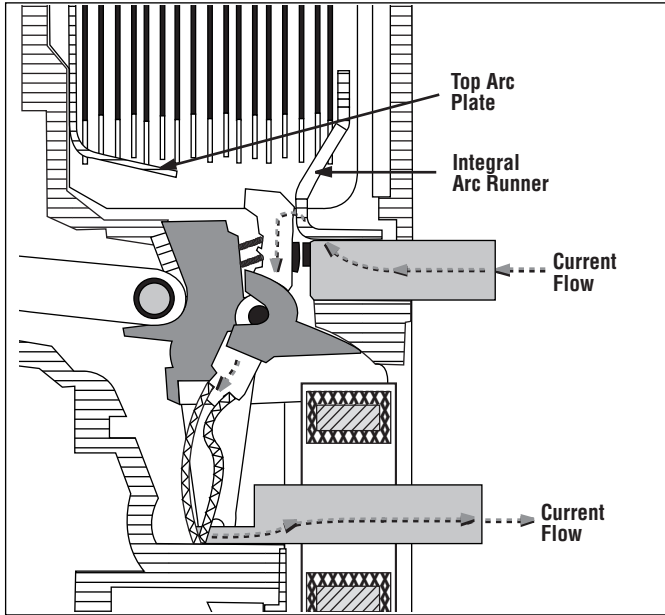

Figure 3-14 Cross Section of Conductor and Arc Control System

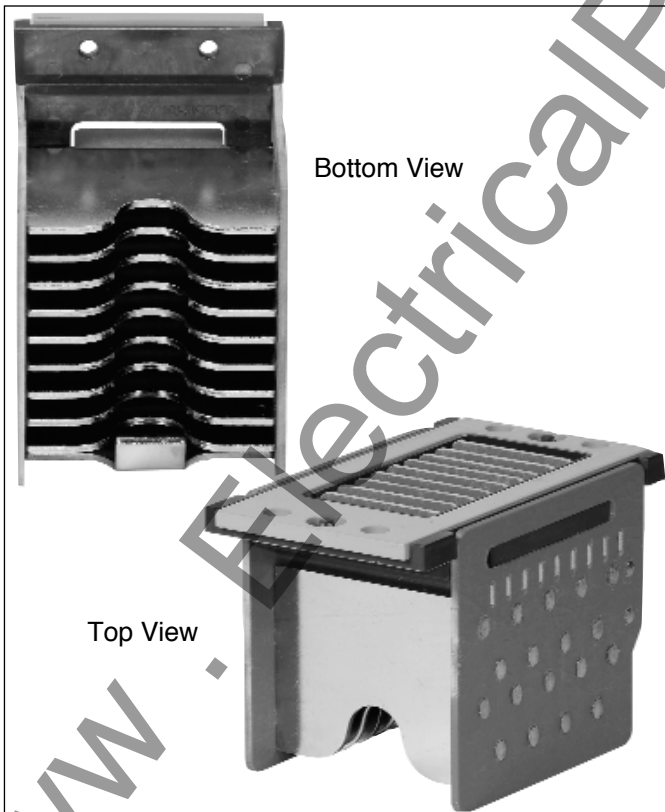

Figure 3-16a Magnum DSX Arc Chute

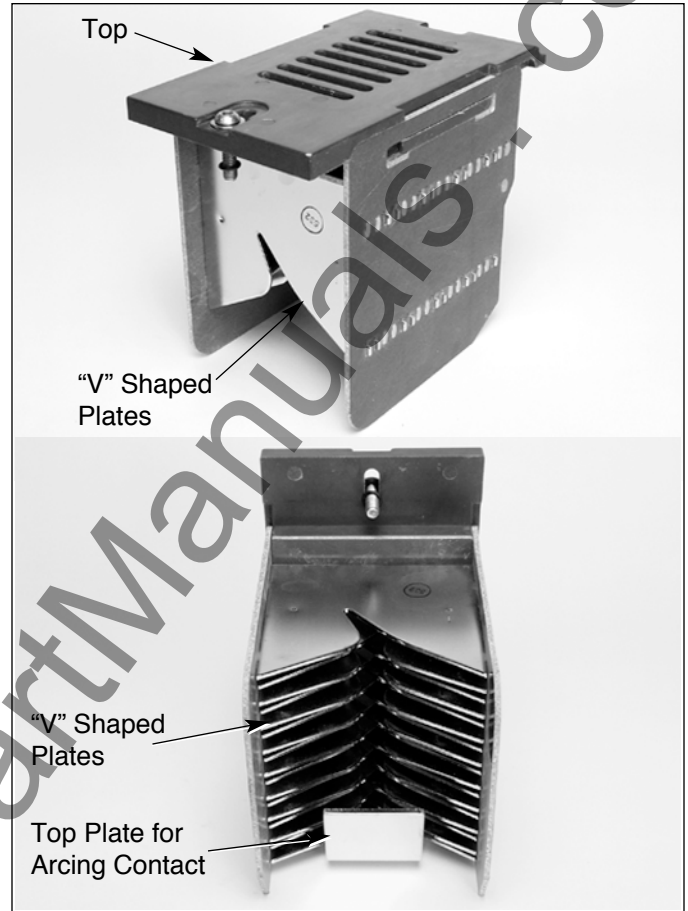

Figure 3-16 Magnum Arc Plate Assembly

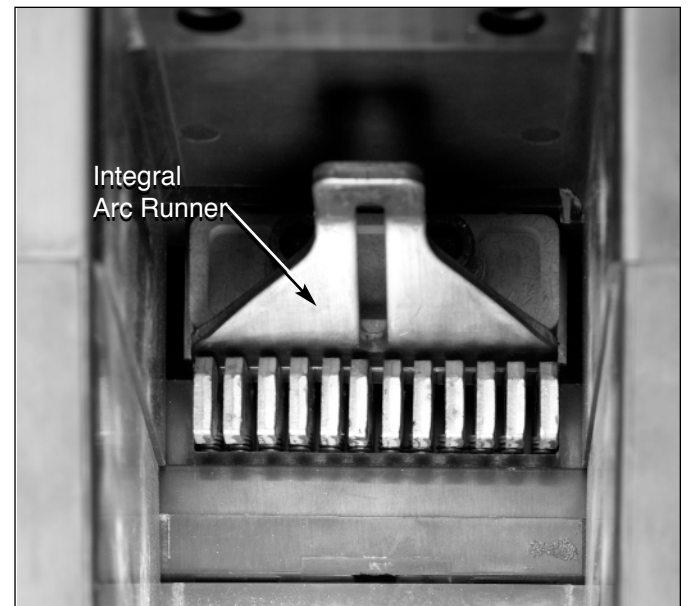

Figure 3-15 Integral Arc Runner Viewed From Top of Arc Chamber (Arc Chute Removed, Circuit Breaker Closed)

3-6 ELECTRONIC TRIPPING SYSTEM

The Magnum DS/DSX/DSL circuit breakers utilize a three part tripping system (Figure 3-17):

- Microprocessor-based trip unit
- Current Sensors
- Trip Actuator

All three parts of the tripping system are discussed here, except that the trip unit itself is not discussed in detail. For detailed information pertaining to the different trip unit models available with Magnum DS/DSX/DSL circuit breakers, refer to the specific instruction leaflet dedicated to the trip units (I.L. 70C1036 and I.L. 70C1037).

3-6.1 MICROPROCESSOR-BASED TRIP UNIT

Magnum circuit breakers use any one of a family of Digitrip RMS trip units whose main features are summarized in Table 3.1. Also, the MDSX family of breakers is intended to be used only with trip units manufactured after May 1, 2005.

Models 520 is plug compatible and interchangeable in the field. Circuit breakers with these trip units can be upgraded to Models 520M and/or 520MC in the field; however additional wiring (for power supply and communications) may be required to take full advantage of the additional features. Contact Cutler-Hammer for upgrading to Model 1150.

The electronic trip units are self-powered. When the circuit breaker is closed, no external power is required to operate their protective systems. Current signal levels and the control power are derived from the current sensors integrally mounted in the circuit breaker.

A functional local test of a major portion of the trip unit's electronic circuitry and the circuit breaker's mechanical tripping action can be verified through the trip unit's test receptacle (Figure 3-18). This is accomplished using a Digitrip (DS Type) Test Kit which provides a secondary injection test that simulates the current sensors. A small hand held Magnum functional Test Kit can also be used to check circuitry and mechanical tripping functions (Figure 3-19).

When the circuit breaker is shipped from the factory, the trip unit's protective functions are normally set at minimum values. For specific overload tripping characteristics and time/current curves to coordinate with a load or system, refer to the trip unit instruction book.

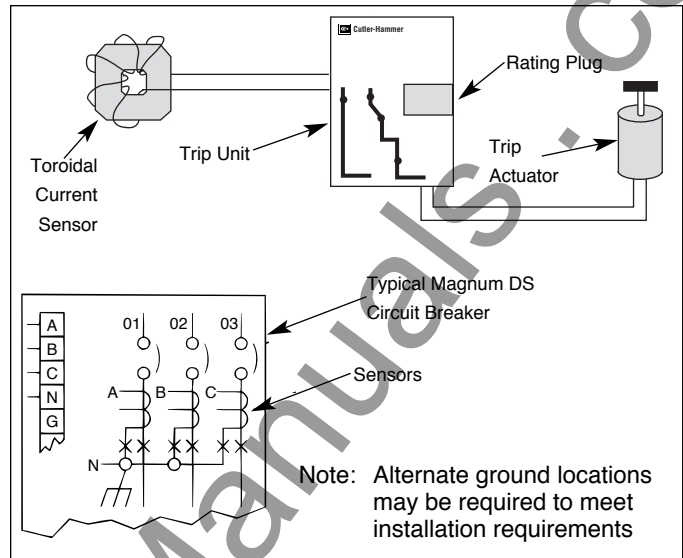

Figure 3-17 Pictorial Diagram of Typical Current Sensing, Processing and Tripping System

Table 3.1 Magnum Digitrip Trip Units

Functions	520	520M ^④	520MC ^④	1150 ^④
LSIG Protection	Yes	Yes	Yes	Yes
Disable (I)	Yes	Yes	Yes	Yes
GF Protection	Yes	Yes	Yes	Yes
GF Alarm	No	Yes	Yes	Yes
Display	No	Yes ^①	Yes ^①	Yes ^②
Programmable	No	No	No	Yes
Metering	No	Yes ^③	Yes ^③	Yes
Power and Energy Values	No	No	No	Yes
Power Quality	No	No	No	Yes
Communication	No	No	Yes	Yes

- ① One-line, (four characters per line) LCD display.
- ② Three-line, (eight characters per line) LED display.
- ③ Phase, neutral, ground, and high load current only.
- ④ Available control voltages are 24/48Vdc, 125Vdc, 120Vac and 240Vac

3-6.2 RATING PLUG

All Magnum DS/DSX/DSL circuit breaker trip units use a fixed type rating plug. The current rating of the rating plug must match the current rating of the integrally mounted current sensors (Figure 2-3, 3-18 and Table 3.2). The rating plug performs several functions:

- 1) It tells the trip unit what the rating is of the current sensors. A label on the front of the rating plug clearly indicates that the rating plug and sensors must have the same rating.
- 2) It determines the maximum instantaneous setting which is a function of the current sensor rating.
- 3) The National Electrical Code (NEC) requires that the maximum ground fault pickup value not exceed 1200 amperes. A properly matched rating plug accomplishes this requirement for higher ampere sensors by incorporating circuitry to identify that level by sensor rating.

If the rating plug is removed from the trip unit, the circuit breaker will trip if it is carrying current. Make certain the rating plug is secured in position with its retaining screw. **Do not torque the retaining screw beyond 15 In-Oz.**

Refer to Table 3.2 for a tabulation of the available rating plugs.

3-6.3 CURRENT SENSORS

Three toroidally wound current sensors are installed at the rear of the circuit breaker on the lower terminals (Figure 3-20). The sensors produce an output current proportional to the load current. Under preselected conditions of current magnitude and time, the sensors furnish the trip unit with a signal and the energy required to trip the circuit breaker.

Neutral current sensors are available for customer installation. The additional sensor is not supplied with the circuit breaker and must be ordered separately. They are wired to the trip unit through the secondary contacts of the circuit breaker.

Refer to Table 3.2 for a tabulation of the available current sensor ratings.

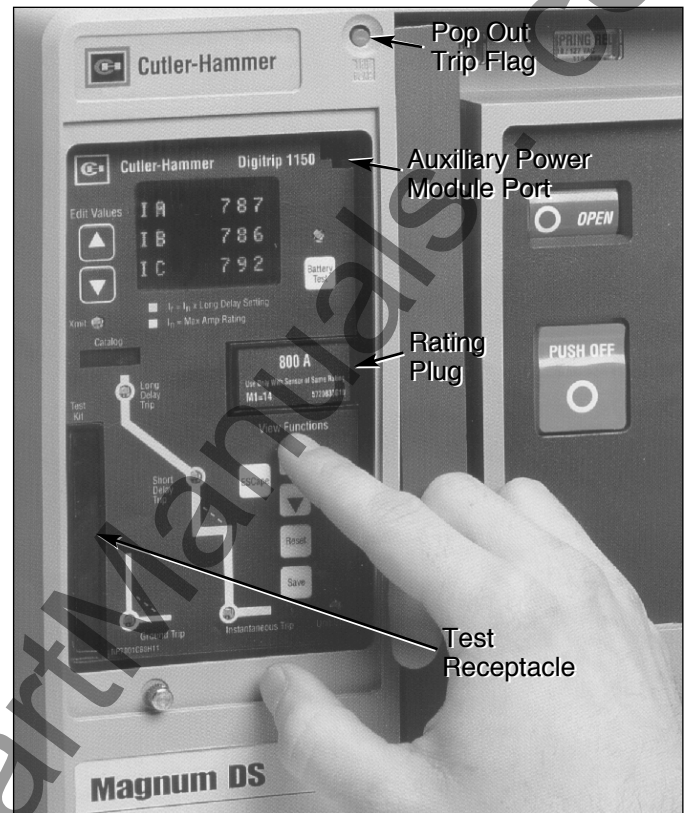

Figure 3-18 Digitrip RMS 1150 Programmable Trip Unit Installed in Magnum DS Circuit Breaker



Figure 3-19 Hand Held Tester

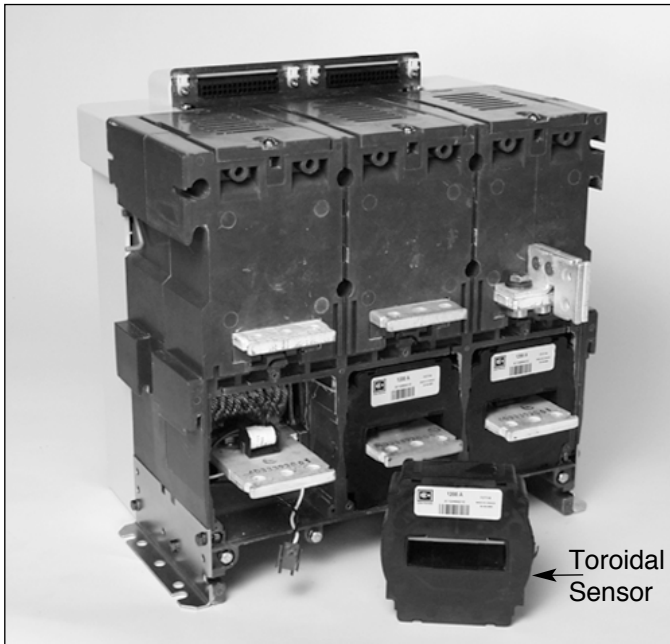

Figure 3-20 Replaceable Current Sensors Shown with Bottom Adapters and Cover Plate Removed

Table 3.2 Magnum Current Sensors and Matching Rating Plugs

Current Rating in Amperes		
200	800	2500
250	1000	3000
300	1200	3200
400	1600	4000
600	2000	5000

3-6.4 TRIP ACTUATOR

The trip actuator is a small cylindrical shaped electromagnetic device which acts mechanically to trip the circuit breaker (Figure 3-17). In general, it is comprised of a permanent magnet, a spring loaded rod to produce the mechanical tripping, and a lever for resetting the actuator after tripping occurs. The electronic trip unit provides a pulse which counteracts the effect of the permanent magnet, allowing the spring loaded rod to act mechanically. The device is reset when the circuit breaker opens.

3-6.5 MECHANICAL TRIP FLAG

A red, pop out mechanical trip indicator is an optional Magnum DS/DSX/DSL feature. It is located above the

trip unit on the breaker’s front faceplate (Figure 3-18). It operates by releasing and popping out any time the circuit breaker trips due to an overcurrent condition. Note that the mechanical trip indicator will not prevent the breaker from being reclosed. The indicator is reset manually by pushing it back in. If the indicator is not reset the circuit breaker will operate normally, but future mechanical trip indication will be lost.

An optional overcurrent trip switch (bell alarm) that operates off the position of the mechanical trip indicator is also available. The switch is reset when the trip indicator is reset.

On optional Digitrip models with LED cause-of-trip indicators, these indicators should also be reset (by pushing momentarily) after the cause of the fault has been diagnosed; this will preserve the internal battery. On trip units equipped for communication the LED reset function can be performed remotely using INCOM commands.

3-6.6 MAKING CURRENT RELEASE

All Magnum DSDSX//DSL circuit breaker trip units have a making current release function. This safety feature prevents the circuit breaker from being closed and latched on a faulted circuit. The non-adjustable release is preset at a peak instantaneous current of $25 \times I_n$; this corresponds to an rms current of $11 \times I_n$ with maximum asymmetry.

The making current release is enabled only for the first 2 cycles following a circuit breaker closing operation. The making current release will trip the circuit breaker instantaneously, release the mechanical (pop-out) indicator and flash the instantaneous LED trip indicator, if so equipped.

3-6.7 HIGH INSTANTANEOUS TRIP OPTION (MAGNUM DS ONLY)

The high instantaneous trip option is installed in 800 to 3200 ampere Magnum DS/DSX circuit breakers with a 100 kA interrupting capacity. In general, the high instantaneous trip is comprised of three small air core sensors, one in each phase, which produce a signal and transmit it back to the trip unit when the 85 kA withstand rating of the circuit breaker is exceeded. The result is an instantaneous trip by the circuit breaker. This high instantaneous trip option permits the 800-3200 ampere Magnum DS circuit breakers to be applied where a 100 kA fault is possible, while selectivity up to 85 kA is maintained.

3-6.8 VOLTAGE TAPS

On circuit breakers with Digitrip 1150 trip units potential taps are required to monitor the three phase voltages. Voltage taps may be placed on either the line (top) or load (bottom) terminals of the breaker at the factory. Figure 3-21 illustrates line-side voltage taps.

3-7 SECONDARY CONTACTS AND CONNECTION DIAGRAMS

A maximum of sixty secondary wiring connection points are available on the standard frame circuit breaker (48 on narrow frame), each dedicated to a specific function

(Figure 3-22). The wiring points are finger safe with no more than two wires per terminal.

Up to two secondary contact plug-in connectors (AMP), each with 30 secondary points, are mounted on the top rear portion of the circuit breaker. The plug-in connectors are protected by a molded hood (Figure 3-23). How many connectors are mounted depends upon a number of considerations, such as whether the circuit breaker is electrically or manually operated and how many features are required. When the front cover of the circuit breaker is removed, the top of each plug-in connector is exposed. A label on each connector identifies the wiring points.



Figure 3-21 Line-Side Voltage Tap for 1150 Trip Unit

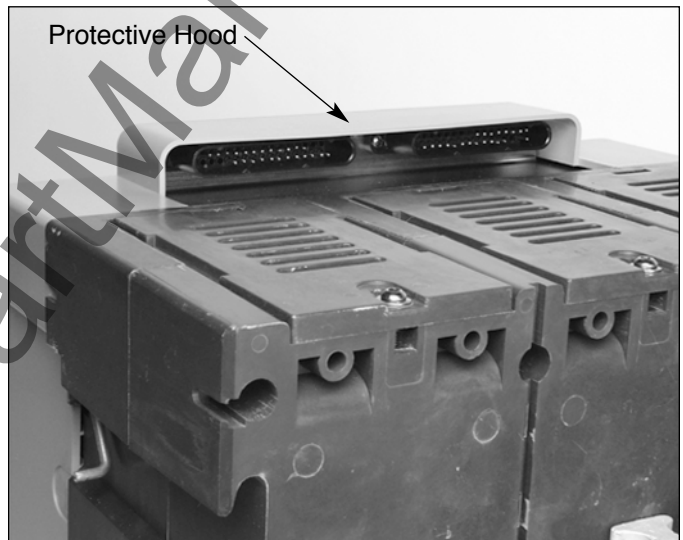

Figure 3-23 Secondary Connector Protective Hood

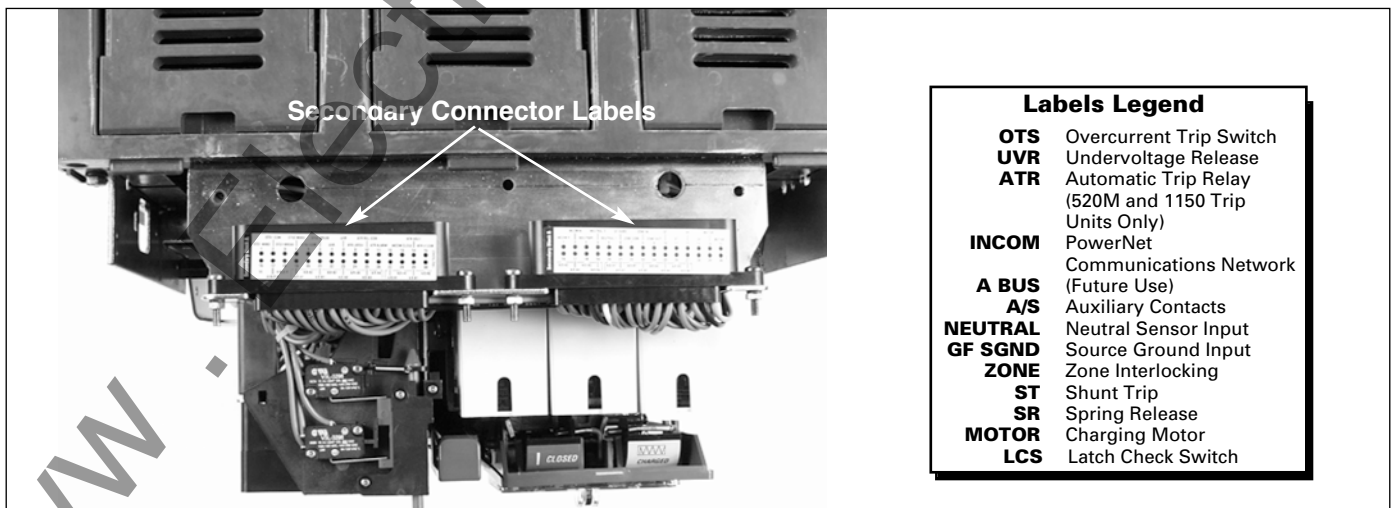

Figure 3-22 Top View Secondary Connectors

Drawout type circuit breakers: Compatible secondary plug-in connectors are mounted on the top front portion of the drawout cassette (Figure 3-24). These connectors match and plug into the circuit breaker mounted connectors. Contact points are wired from the cassette's plug-in connectors to cassette mounted terminal blocks. The terminal blocks are also mounted on the top front portion of the cassette. The secondary terminals have finger-proof hinged covers with small holes for probe testing.

Fixed type circuit breakers: There are two secondary connection options:

- (1) Without Terminal Block
- (2) With Terminal Block

1. Without Terminal Block - If a terminal block for customer use is not required, the circuit breaker is supplied with both plug-in connectors (male and female) just described in the two previous paragraphs. The plug-in connectors are joined and attached to the top portion of the circuit breaker. The customer can plug secondary wiring with crimp-on connectors into back of the plug-in connectors; subsequently the connections to the circuit breaker can be quickly joined or separated as required.

2. With Terminal Block - For those customers preferring to wire to a terminal block, terminal blocks with finger-proof hinged covers are added to the secondary configuration just described for a fixed circuit breaker "without a terminal block." The terminal blocks are wired to the plug-in connectors and also permanently attached to the upper rear portion of the circuit breaker (Figures 3-2 and 3-4).

A standard tool is available from the plug-in connector manufacturer (AMP) to facilitate the removal of secondary wiring from a plug-in connector, or contact Cutler-Hammer for assistance (Figure 3-25). The connector halves must be separated to use this tool.

3-7.1 CONNECTION DIAGRAMS

The connection diagrams for all Magnum circuit breakers using Digitrip RMS trip units are shown in Figures 3-26 through 3-46.

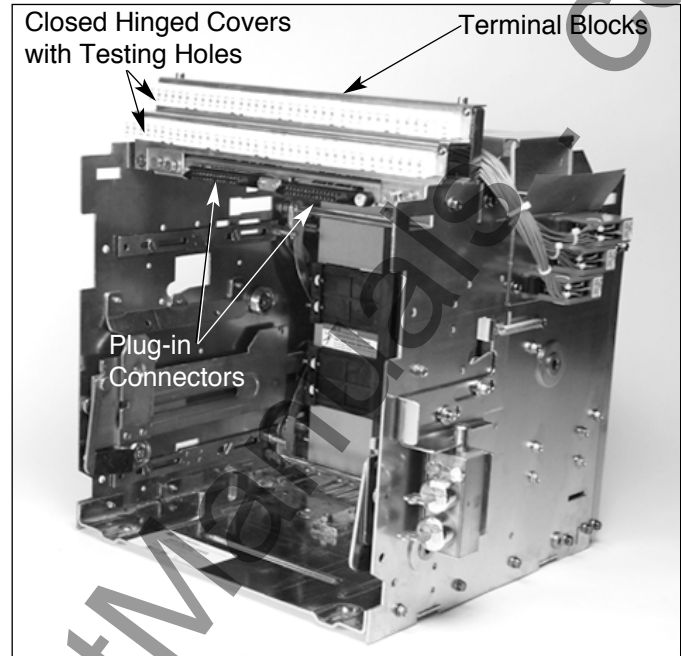

Figure 3-24 Typical Cassette Mounted Secondary Wiring

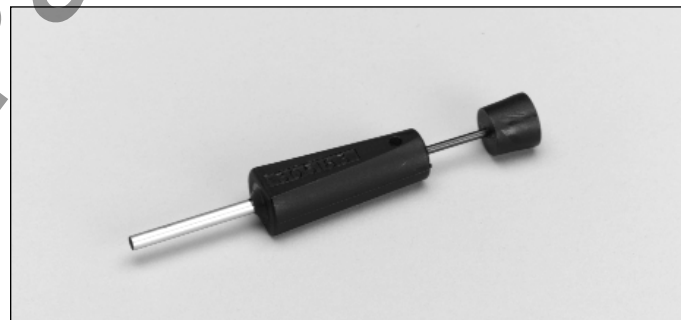

Figure 3-25 AMP Secondary Wiring Removal Tool

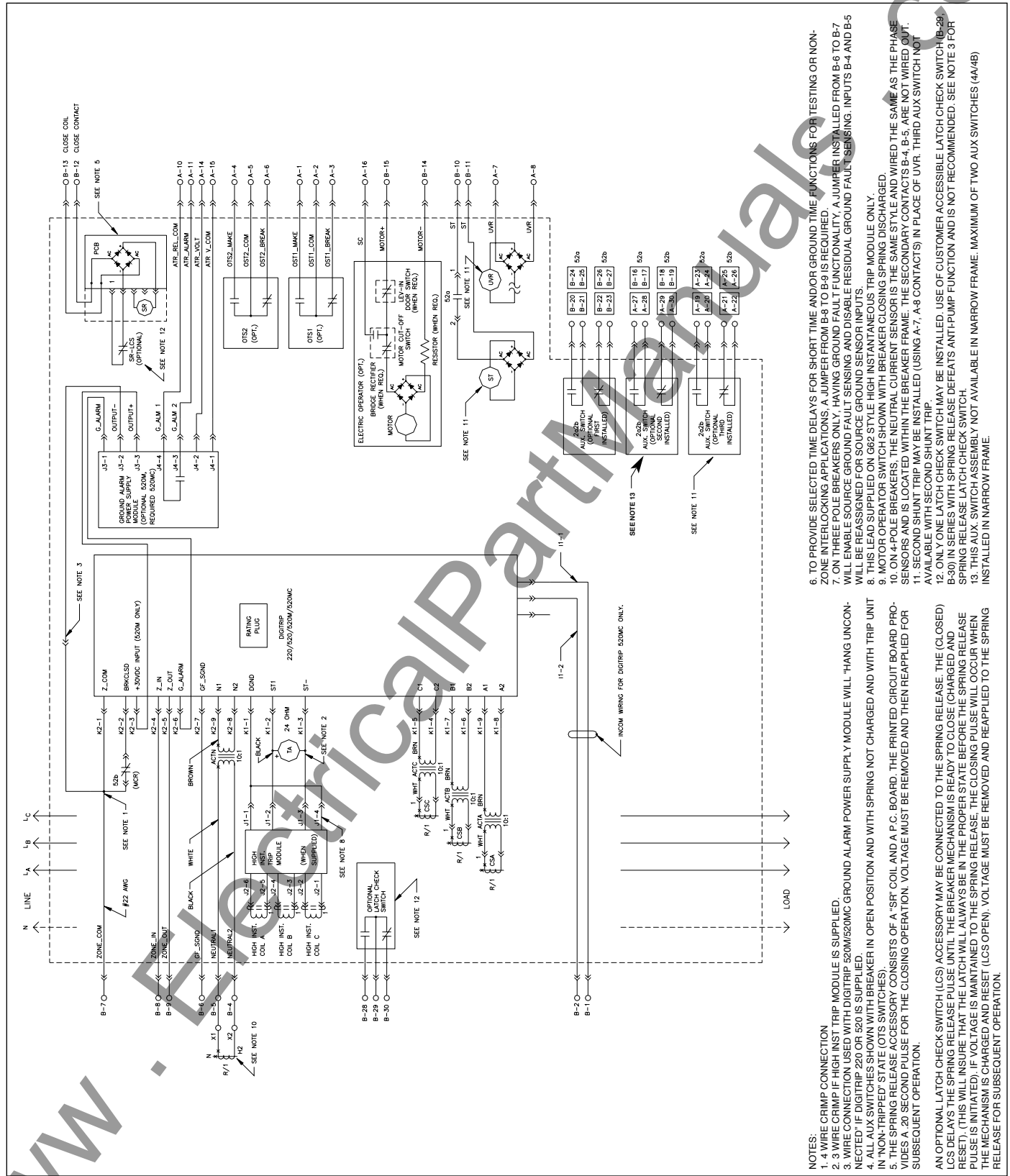

Figure 3-26 Connection Diagram for Narrow and Standard Frame with Digitrip 520 and 520M (except Narrow 100kA ratings)

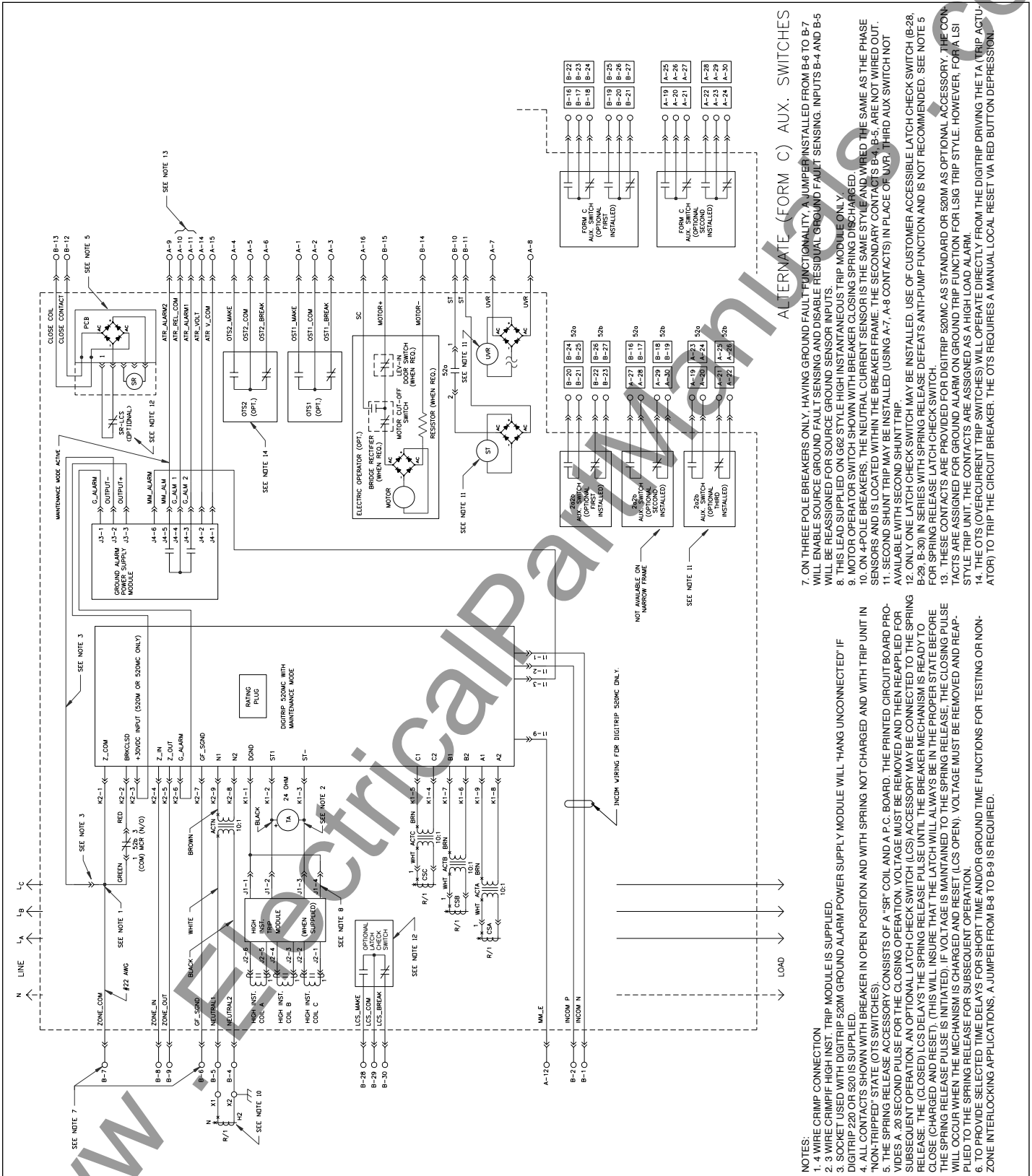
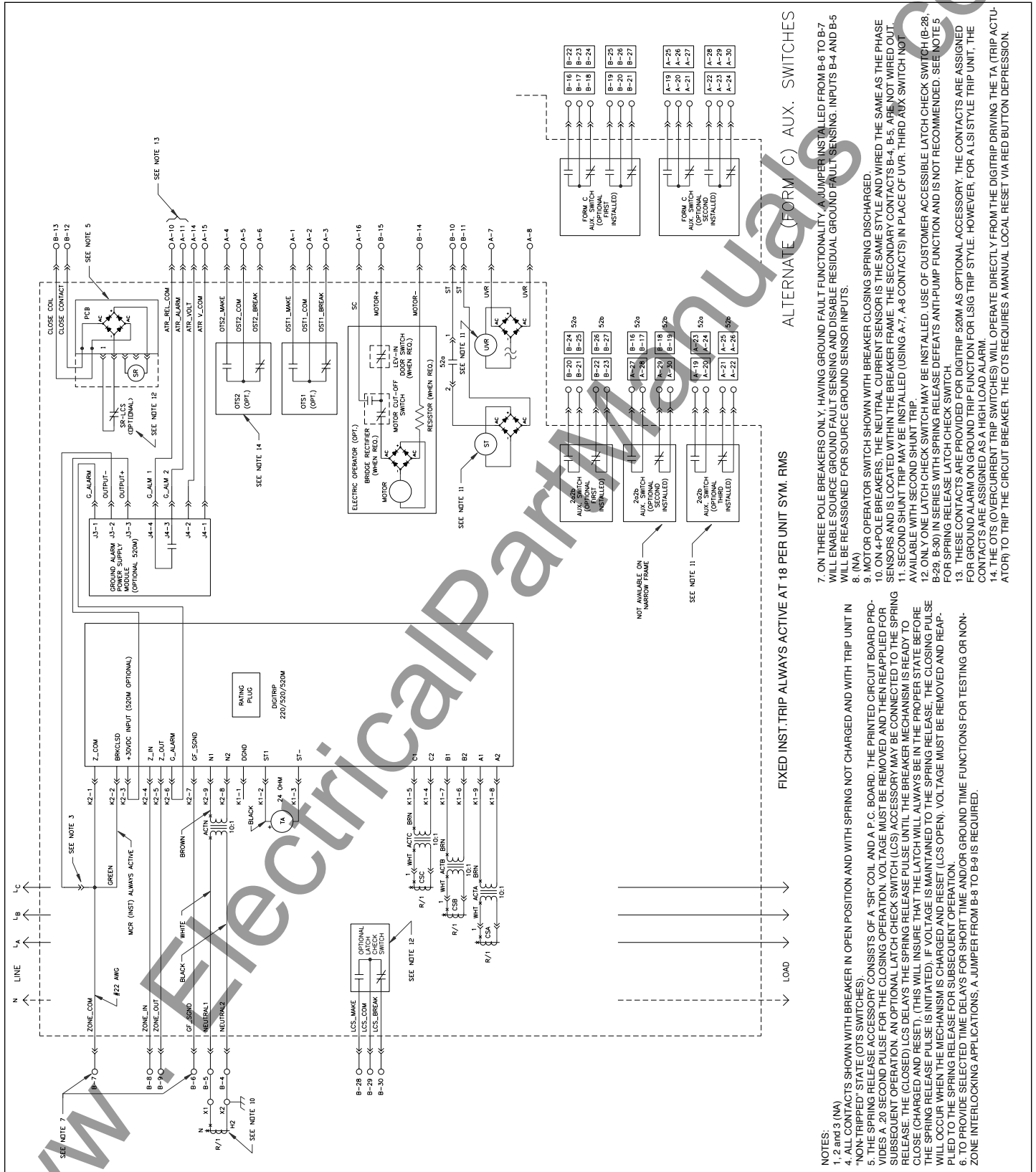

Figure 3-27 Connection Diagram for Narrow and Standard Frame with Digitrip 520MC (except Narrow 100KA ratings)



ALTERNATE (FORM C) AUX. SWITCHES

FIXED INST. TRIP ALWAYS ACTIVE AT 18 PER UNIT SYM. RMS

- NOTES:
1. 2 BRN.3 (NA)
 2. BRN.3 (NA)
 3. ALL CONTACTS SHOWN WITH BREAKER IN OPEN POSITION AND WITH SPRING NOT CHARGED AND WITH TRIP UNIT IN "NON-TRIPPED" STATE (OTS SWITCHES).
 4. ALL CONTACTS SHOWN WITH BREAKER IN OPEN POSITION AND WITH SPRING NOT CHARGED AND WITH TRIP UNIT IN "NON-TRIPPED" STATE (OTS SWITCHES).
 5. THE SPRING RELEASE ACCESSORY CONSISTS OF A "SR" COIL AND A P.C. BOARD. THE PRINTED CIRCUIT BOARD PROVIDES A 20 SECOND PULSE FOR THE CLOSING OPERATION. VOLTAGE MUST BE REMOVED AND THEN REAPPLIED FOR SUBSEQUENT OPERATION. AN OPTIONAL LATCH CHECK SWITCH (LCS) ACCESSORY MAY BE CONNECTED TO THE SPRING RELEASE. THE (CLOSED) LCS DELAYS THE SPRING RELEASE PULSE UNTIL THE BREAKER MECHANISM IS READY TO CLOSE (CHARGED AND RESET). (THIS WILL INSURE THAT THE LATCH WILL ALWAYS BE IN THE PROPER STATE BEFORE THE SPRING RELEASE PULSE IS INITIATED). IF VOLTAGE IS MAINTAINED TO THE SPRING RELEASE, THE CLOSING PULSE WILL OCCUR WHEN THE MECHANISM IS CHARGED AND RESET (LCS OPEN). VOLTAGE MUST BE REMOVED AND REAPPLIED TO THE SPRING RELEASE FOR SUBSEQUENT OPERATION.
 6. TO PROVIDE SELECTED TIME DELAYS FOR SHORT TIME AND/OR GROUND TIME FUNCTIONS FOR TESTING OR NON-ZONE INTERLOCKING APPLICATIONS, A JUMPER FROM B-8 TO B-9 IS REQUIRED.
 7. ON THREE POLE BREAKERS ONLY, HAVING GROUND FAULT FUNCTIONALITY, A JUMPER INSTALLED FROM B-6 TO B-7 WILL ENABLE SOURCE GROUND FAULT SENSING AND DISABLE RESIDUAL GROUND FAULT SENSING. INPUTS B-4 AND B-5 WILL BE REASSIGNED FOR SOURCE GROUND SENSOR INPUTS.
 8. (NA)
 9. MOTOR OPERATOR SWITCH SHOWN WITH BREAKER CLOSING SPRING DISCHARGED.
 10. ON 4-POLE BREAKERS, THE NEUTRAL CURRENT SENSOR IS THE SAME STYLE AND WIRED THE SAME AS THE PHASE SENSORS AND IS LOCATED WITHIN THE BREAKER FRAME. THE SECONDARY CONTACTS B-4, B-5, ARE NOT WIRED OUT.
 11. SECOND SHUNT TRIP MAY BE INSTALLED (USING A-7, A-8 CONTACTS) IN PLACE OF UVR. THIRD AUX SWITCH NOT AVAILABLE WITH SECOND SHUNT TRIP.
 12. ONLY ONE LATCH CHECK SWITCH MAY BE INSTALLED. USE OF CUSTOMER ACCESSIBLE LATCH CHECK SWITCH (B-28, B-29, B-30) IN SERIES WITH SPRING RELEASE DEFEATS ANTI-PUMP FUNCTION AND IS NOT RECOMMENDED. SEE NOTE 5 FOR SPRING RELEASE LATCH CHECK SWITCH.
 13. THESE CONTACTS ARE PROVIDED FOR DIGITRIP 520M AS OPTIONAL ACCESSORY. THE CONTACTS ARE ASSIGNED FOR GROUND ALARM ON GROUND TRIP FUNCTION FOR LSIg TRIP STYLE. HOWEVER, FOR A LSI STYLE TRIP UNIT, THE CONTACTS ARE ASSIGNED AS A HIGH LOAD ALARM.
 14. THE OTS (OVERCURRENT TRIP SWITCHES) WILL OPERATE DIRECTLY FROM THE TA (TRIP ACTUATOR) TO TRIP THE CIRCUIT BREAKER. THE OTS REQUIRES A MANUAL LOCAL RESET VIA RED BUTTON DEPRESSION.

Figure 3-28 Connection Diagram for Narrow 100kA Rating Frame with Digitrip 520 and 520M

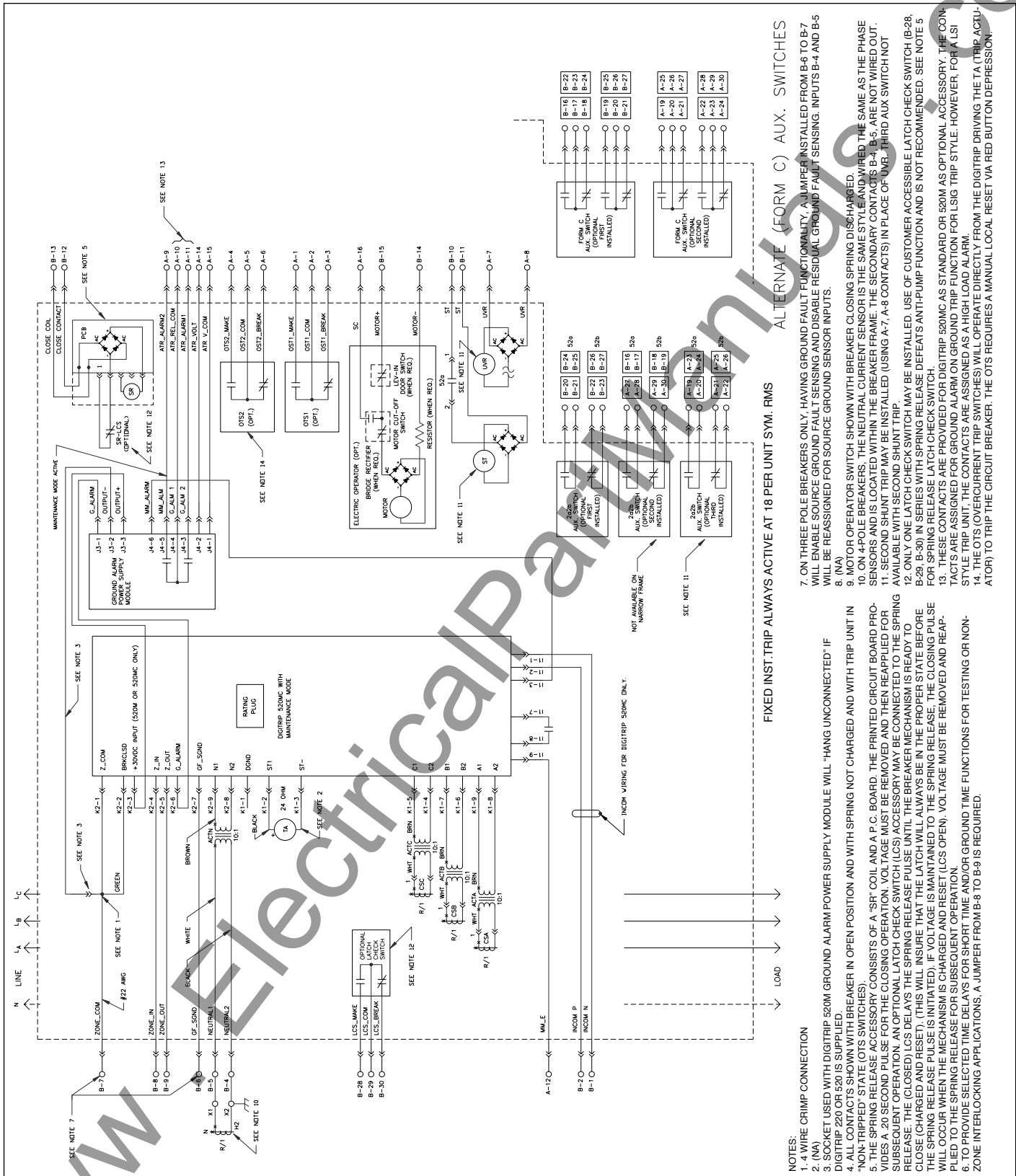

Figure 3-29 Connection Diagram for Narrow 100kA Rating Frame with Digitrip 520MC

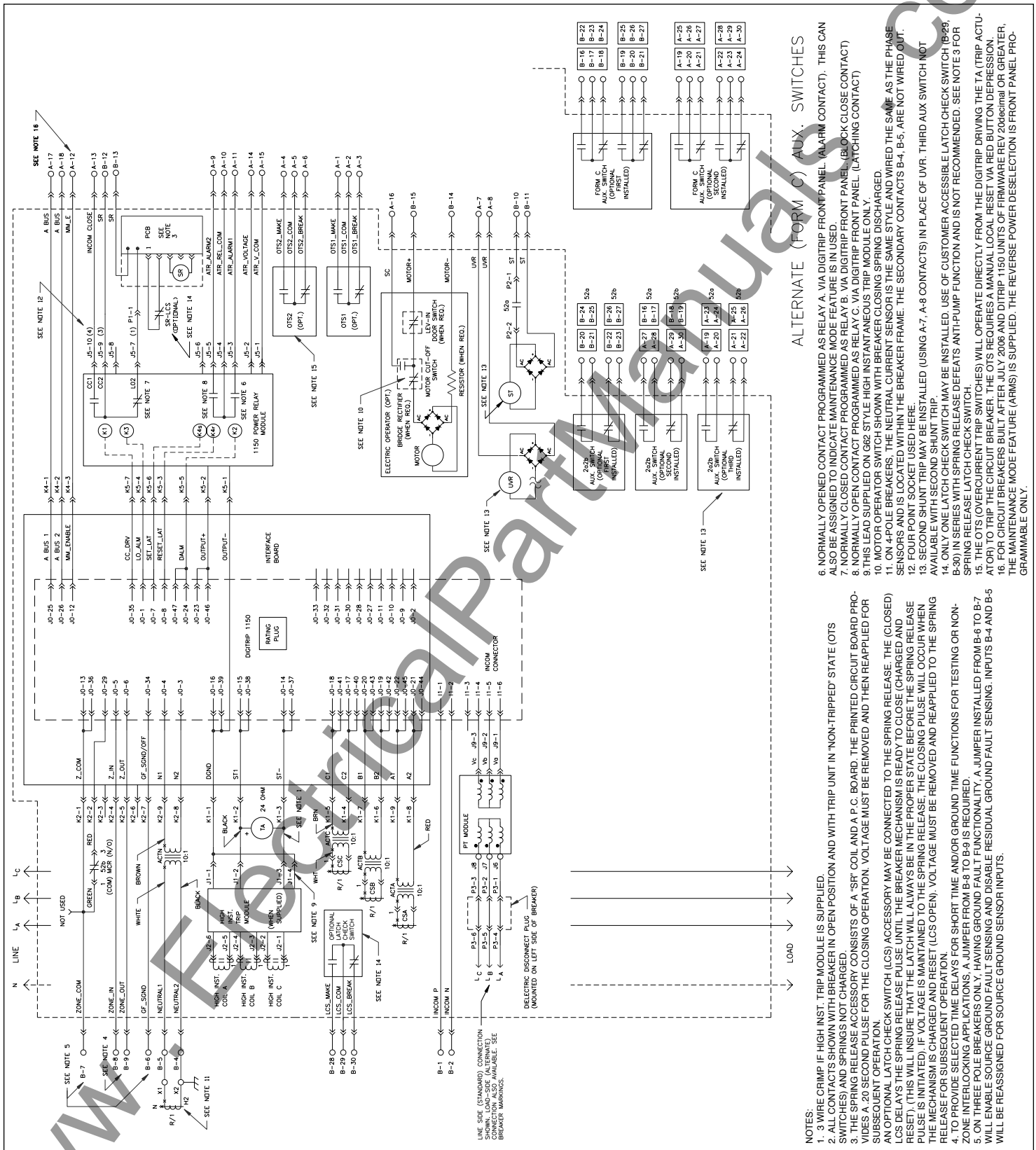

Figure 3-30 Connection Diagram for Standard and Narrow (except 100kA ratings) Frame with Digitrip 1150

- NOTES:
1. 3 WIRE CRIMP IF HIGH INST. TRIP MODULE IS SUPPLIED.
 2. ALL CONTACTS SHOWN WITH BREAKER IN OPEN POSITION AND WITH TRIP UNIT IN "NON-TRIPPED" STATE (OTS SWITCHES) AND SPRINGS NOT CHARGED.
 3. THE SPRING RELEASE ACCESSORY CONSISTS OF A "SF" COIL AND A P.C. BOARD. THE PRINTED CIRCUIT BOARD PROVIDES A 20 SECOND PULSE FOR THE CLOSING OPERATION. VOLTAGE MUST BE REMOVED AND THEN REAPPLIED FOR SUBSEQUENT OPERATION.
 4. TO PROVIDE FOR SUBSEQUENT OPERATION AN OPTIONAL LATCH CHECK SWITCH (LCS) ACCESSORY MAY BE CONNECTED TO THE SPRING RELEASE. THE (CLOSED) LCS RELEASES THE SPRING RELEASE PULSE UNTIL THE BREAKER MECHANISM IS READY TO CLOSE (CHARGED AND RESET). (THIS WILL INSURE THAT THE LATCH WILL ALWAYS BE IN THE PROPER STATE BEFORE THE SPRING RELEASE PULSE IS INITIATED). IF VOLTAGE IS MAINTAINED TO THE SPRING RELEASE. THE CLOSING PULSE WILL OCCUR WHEN THE MECHANISM IS CHARGED AND RESET (LCS OPEN). VOLTAGE MUST BE REMOVED AND REAPPLIED TO THE RELEASE FOR SUBSEQUENT OPERATION.
 5. ON THREE POLE BREAKERS ONLY. A JUMPER FROM B-8 TO B-9 IS REQUIRED.
 6. ON THREE POLE BREAKERS ONLY. HAVING GROUND FAULT FUNCTIONALITY. A JUMPER INSTALLED FROM B-6 TO B-7 WILL ENABLE SOURCE GROUND FAULT SENSING AND DISABLE RESIDUAL GROUND FAULT SENSING. INPUTS B-4 AND B-5 WILL BE REASSIGNED FOR SOURCE GROUND SENSOR INPUTS.

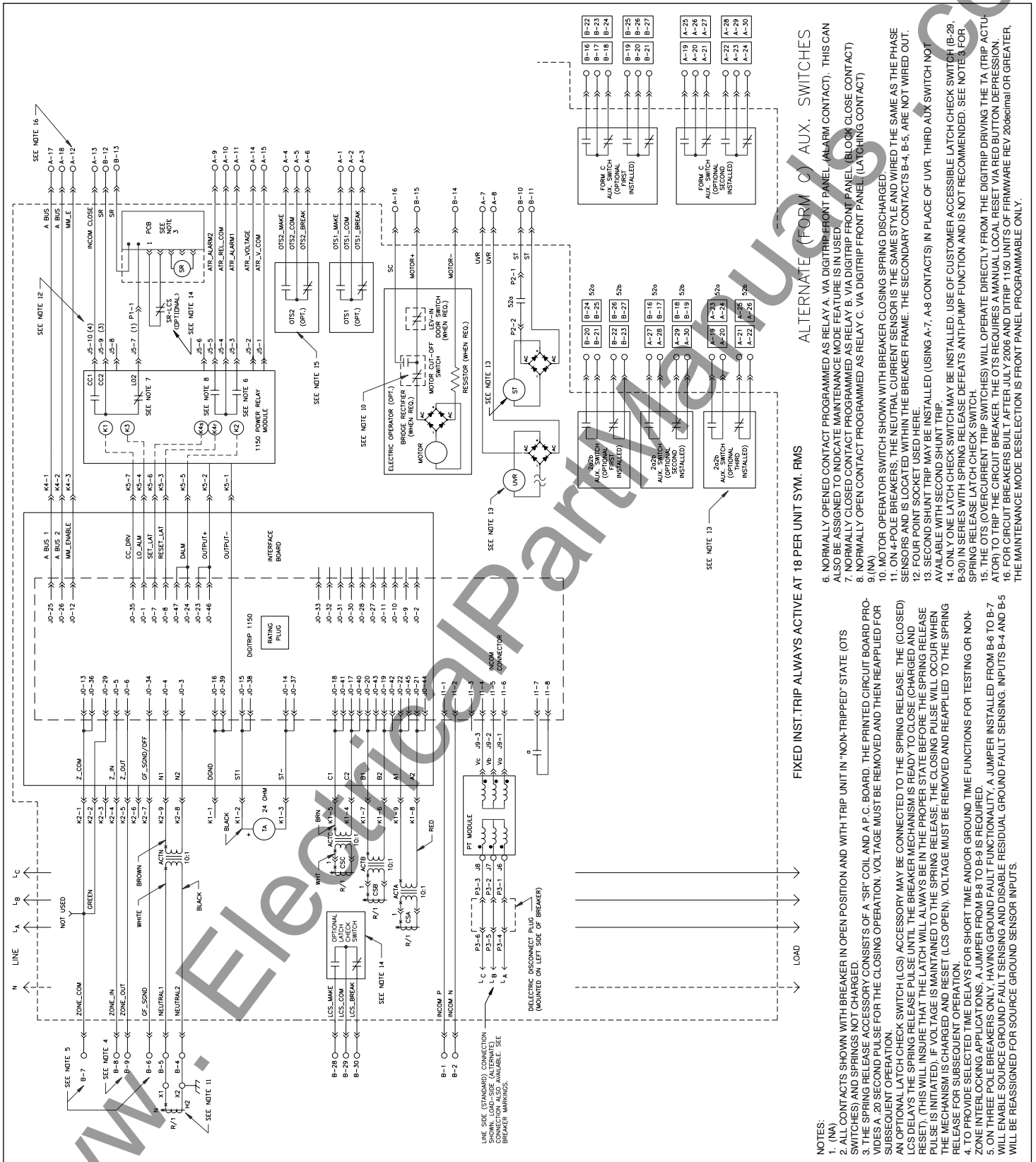

Figure 3-31 Connection Diagram for Narrow Frame (100kA rating) with Digitrip 1150

- NOTES:
- (NA)
 - ALL CONTACTS SHOWN WITH BREAKER IN OPEN POSITION AND WITH TRIP UNIT IN "NON-TRIPPED" STATE (OTS SWITCHES) AND SPRINGS NOT CHARGED.
 - THE SPRING RELEASE ACCESSORY CONSISTS OF A "SR" COIL AND A P.C. BOARD. THE PRINTED CIRCUIT BOARD PROVIDES A .20 SECOND PULSE FOR THE CLOSING OPERATION. VOLTAGE MUST BE REMOVED AND THEN REAPPLIED FOR SUBSEQUENT OPERATION.
 - AN OPTIONAL LATCH CHECK SWITCH (LCS) ACCESSORY MAY BE CONNECTED TO THE SPRING RELEASE. THE (CLOSED) LCS DELAYS THE SPRING RELEASE PULSE UNTIL THE BREAKER MECHANISM IS READY TO CLOSE (CHARGED AND RESET). (THIS WILL INSURE THAT THE LATCH WILL ALWAYS BE IN THE PROPER STATE BEFORE THE SPRING RELEASE PULSE IS INITIATED). IF VOLTAGE IS MAINTAINED TO THE SPRING RELEASE, THE CLOSING PULSE WILL OCCUR WHEN THE MECHANISM IS CHARGED AND RESET (LCS OPEN). VOLTAGE MUST BE REMOVED AND REAPPLIED TO THE SPRING RELEASE FOR SUBSEQUENT OPERATION.
 - TO PROVIDE SELECTED TIME DELAYS FOR SHORT TIME AND/OR GROUND TIME FUNCTIONS FOR TESTING OR NON-ZONE INTERLOCKING APPLICATIONS, A JUMPER FROM B-6 TO B-9 IS REQUIRED.
 - ON THREE POLE BREAKERS ONLY, HAVING GROUND FAULT FUNCTIONALITY, A JUMPER INSTALLED FROM B-6 TO B-7 WILL ENABLE SOURCE GROUND FAULT SENSING AND DISABLE RESIDUAL GROUND FAULT SENSING. INPUTS B-4 AND B-5 WILL BE REASSIGNED FOR SOURCE GROUND SENSOR INPUTS.

FIXED INST. TRIP ALWAYS ACTIVE AT 18 PER UNIT SYM. RMS

ALTERNATE (FORM C) AUX. SWITCHES

- NORMALLY OPENED CONTACT PROGRAMMED AS RELAY A. VIA DIGITRIP FRONT PANEL. (ALARM CONTACT). THIS CAN ALSO BE ASSIGNED TO INDICATE MAINTENANCE MODE FEATURE (IS IN USED)
- NORMALLY CLOSED CONTACT PROGRAMMED AS RELAY B. VIA DIGITRIP FRONT PANEL. (BLOCK CLOSE CONTACT)
- NORMALLY OPEN CONTACT PROGRAMMED AS RELAY C. VIA DIGITRIP FRONT PANEL. (LATCHING CONTACT)
- (NA)
- MOTOR OPERATOR SWITCH SHOWN WITH BREAKER CLOSING SPRING DISCHARGED
- ON 4-POLE BREAKERS, THE NEUTRAL CURRENT SENSOR IS THE SAME STYLE AND WIRED THE SAME AS THE PHASE SENSORS AND IS LOCATED WITHIN THE BREAKER FRAME. THE SECONDARY CONTACTS B-4, B-5, ARE NOT WIRED OUT.
- FOUR POINT SOCKET USED HERE.
- SECOND SHUNT TRIP MAY BE INSTALLED (USING A-7, A-8 CONTACTS) IN PLACE OF UVR. THIRD AUX SWITCH NOT AVAILABLE WITH SECOND SHUNT TRIP.
- ONLY ONE LATCH CHECK SWITCH MAY BE INSTALLED (USING A-7, A-8 CONTACTS) IN PLACE OF UVR. THIRD AUX SWITCH NOT AVAILABLE WITH SECOND SHUNT TRIP.
- THE OTS (OVERCURRENT TRIP SWITCH) WILL OPERATE DIRECTLY FROM THE DIGITRIP DRIVING THE TA (TRIP ACTUATOR) TO TRIP THE CIRCUIT BREAKER. THE OTS REQUIRES A MANUAL LOCAL RESET VIA RED BUTTON DEPRESSION.
- FOR CIRCUIT BREAKERS BUILT AFTER JULY 2006 AND DIGITRIP 1150 UNITS OF FIRMWARE REV 20dec06 OR GREATER, THE MAINTENANCE MODE DESELECTION IS FRONT PANEL PROGRAMMABLE ONLY.

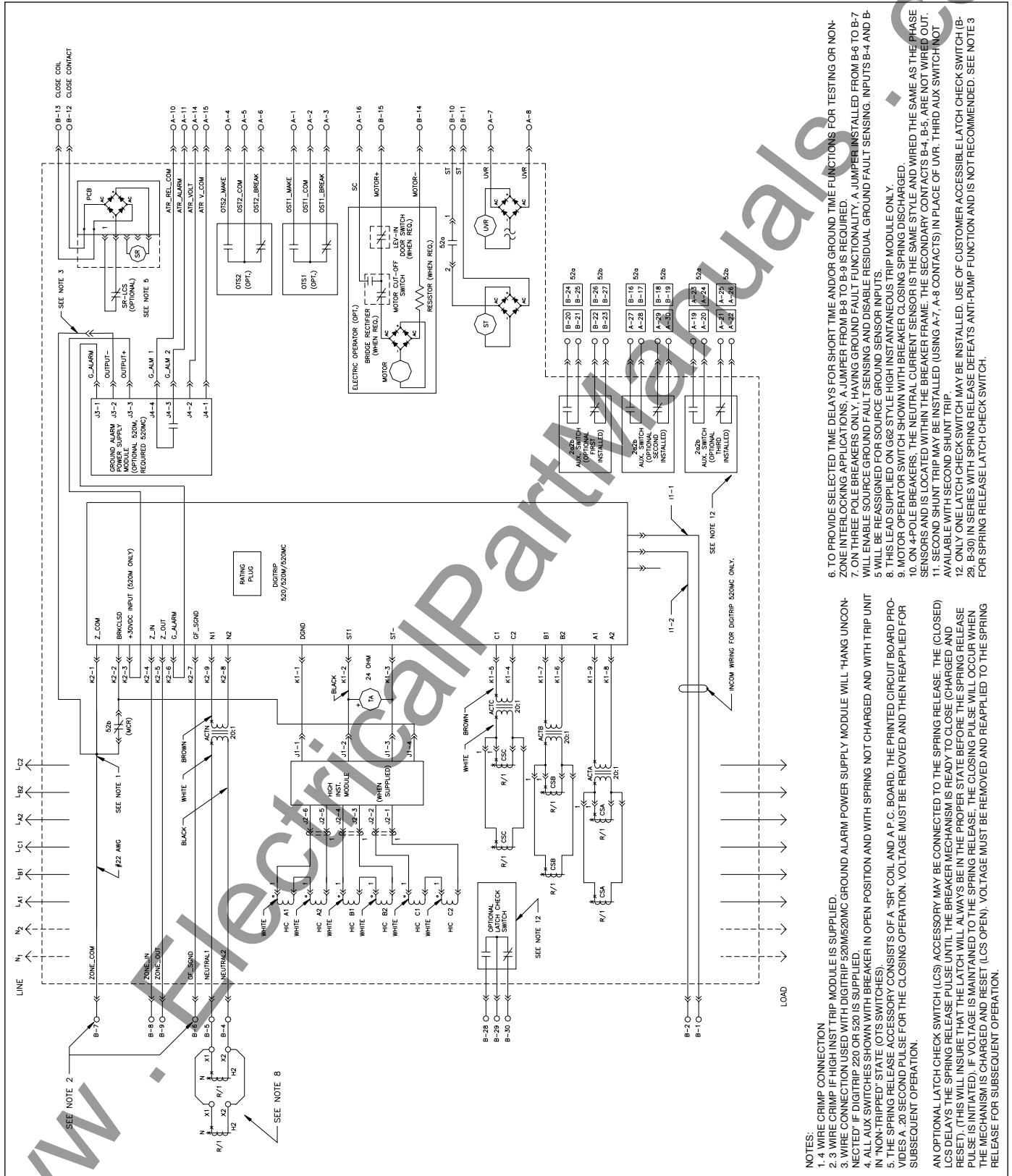
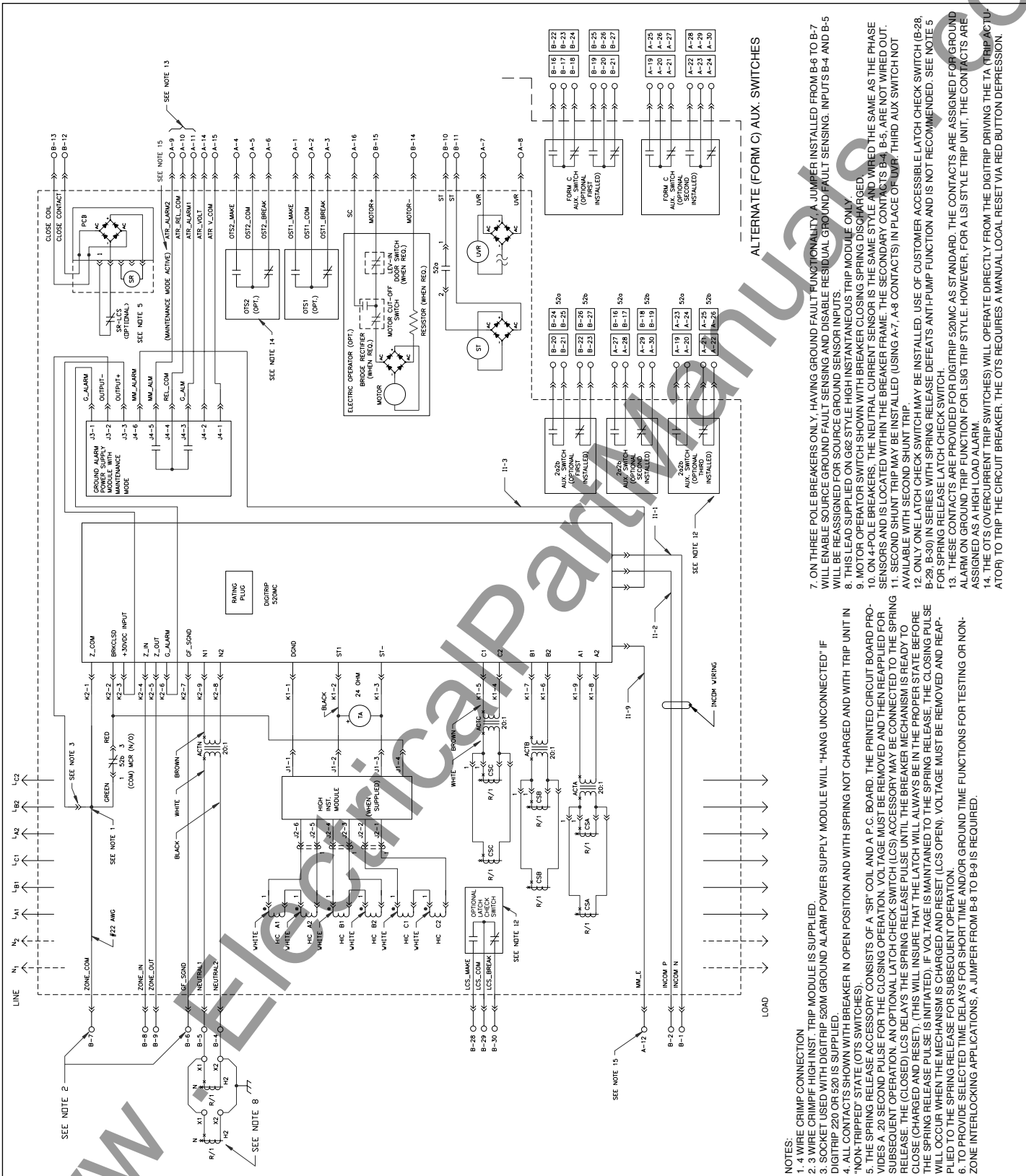
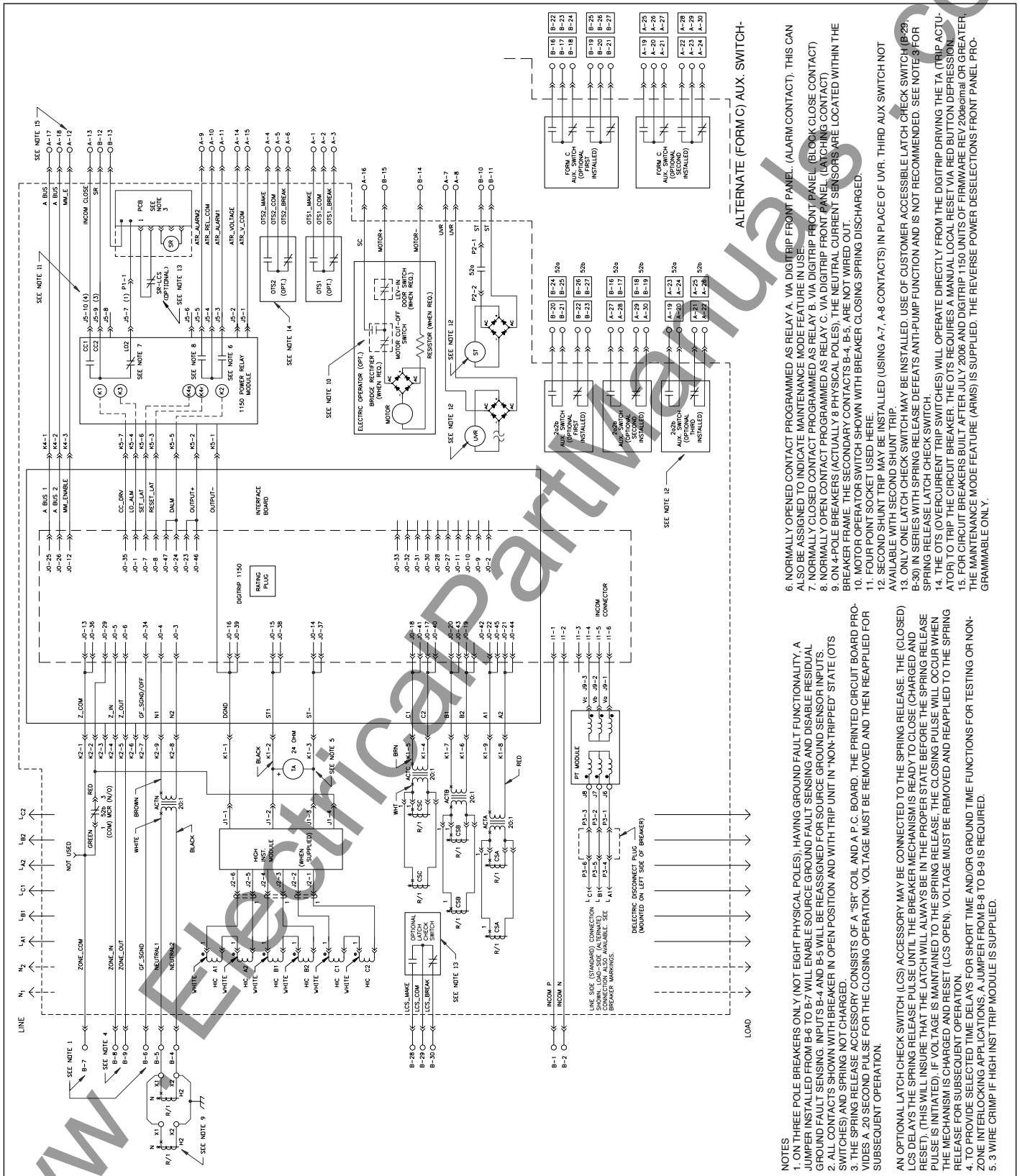

Figure 3-32 Connection Diagram for Double-wide Frame (except MDSX) with Digitrip 520 and 520M with ABCABC Configuration



- NOTES:
- 4 WIRE CRIMP CONNECTION
 - 3 WIRE CRIMP HIGH INST. TRIP MODULE IS SUPPLIED.
 - SOCKET USED WITH DIGITRIP 520M GROUND ALARM POWER SUPPLY MODULE WILL "HANG UNCONNECTED" IF DIGITRIP 220 OR 520 IS SUPPLIED.
 - ALL CONTACTS SHOWN WITH BREAKER IN OPEN POSITION AND WITH SPRING NOT CHARGED AND WITH TRIP UNIT IN "NON-TRIPPED" STATE (OTS SWITCHES).
 - THE SPRING RELEASE ACCESSORY CONSISTS OF A "SR" COIL AND A P.C. BOARD. THE PRINTED CIRCUIT BOARD PROVIDES A 20 SECOND PULSE FOR THE CLOSING OPERATION. VOLTAGE MUST BE REMOVED AND THEN REAPPLIED FOR SUBSEQUENT OPERATION. AN OPTIONAL LATCH CHECK SWITCH (LCS) ACCESSORY MAY BE CONNECTED TO THE SPRING RELEASE. THE (CLOSED) LCS DELAYS THE SPRING RELEASE PULSE UNTIL THE BREAKER MECHANISM IS READY TO CLOSE (CHARGE AND RESET). THIS WILL INSURE THAT THE LATCH WILL ALWAYS BE IN THE PROPER STATE BEFORE THE SPRING RELEASE PULSE IS INITIATED. IF VOLTAGE IS MAINTAINED TO THE SPRING RELEASE, THE CLOSING PULSE WILL OCCUR WHEN THE MECHANISM IS CHARGED AND RESET (LCS OPEN). VOLTAGE MUST BE REMOVED AND REAPPLIED TO THE SPRING RELEASE FOR SUBSEQUENT OPERATION.
 - TO PROVIDE SELECTED TIME DELAYS FOR SHORT TIME AND/OR GROUND TIME FUNCTIONS FOR TESTING OR NON-ZONE INTERLOCKING APPLICATIONS, A JUMPER FROM B-8 TO B-9 IS REQUIRED.

Figure 3-33 Connection Diagram for Double-wide Frame (except MDSX) with Digitrip 520MC with ABCABC Configuration



- NOTES**
1. ON THREE POLE BREAKERS ONLY (NOT EIGHT PHYSICAL POLES), HAVING GROUND FAULT FUNCTIONALITY, A JUMPER INSTALLED FROM B-6 TO B-7 WILL ENABLE SOURCE GROUND FAULT SENSING AND DISABLE RESIDUAL GROUND FAULT SENSING. INPUTS B-4 AND B-5 WILL BE REASSIGNED FOR SOURCE GROUND SENSOR INPUTS.
 2. ALL CONTACTS SHOWN WITH BREAKER IN OPEN POSITION AND WITH TRIP UNIT IN 'NON-TRIPPED' STATE (OTS SWITCHES) AND SPRING NOT CHARGED.
 3. THE SPRING RELEASE ACCESSORY CONSISTS OF A 'SR' COIL AND A P.C. BOARD. THE PRINTED CIRCUIT BOARD PROVIDES A 20 SECOND PULSE FOR THE CLOSING OPERATION. VOLTAGE MUST BE REMOVED AND THEN REAPPLIED FOR SUBSEQUENT OPERATION.
 4. TO PROVIDE SELECTED TIME DELAYS FOR SHORT TIME AND/OR GROUND TIME FUNCTIONS FOR TESTING OR NON-ZONE INTERLOCKING APPLICATIONS, A JUMPER FROM B-8 TO B-9 IS REQUIRED.
 5. 3 WIRE CRIMP IF HIGH INST TRIP MODULE IS SUPPLIED.
- AN OPTIONAL LATCH CHECK SWITCH (LCS) ACCESSORY MAY BE CONNECTED TO THE SPRING RELEASE. THE (CLOSED) LCS DELAYS THE SPRING RELEASE PULSE UNTIL THE BREAKER MECHANISM IS READY TO CLOSE (CHARGED AND RESET). (THIS WILL INSURE THAT THE LATCH WILL ALWAYS BE IN THE PROPER STATE BEFORE THE SPRING RELEASE PULSE IS INITIATED). IF VOLTAGE IS MAINTAINED TO THE SPRING RELEASE, THE CLOSING PULSE WILL OCCUR WHEN THE MECHANISM IS CHARGED AND RESET (LCS OPEN). VOLTAGE MUST BE REMOVED AND REAPPLIED TO THE SPRING RELEASE FOR SUBSEQUENT OPERATION.

6. NORMALLY OPENED CONTACT PROGRAMMED AS RELAY A VIA DIGITRIP FRONT PANEL. (ALARM CONTACT). THIS CAN ALSO BE ASSIGNED TO INDICATE MAINTENANCE MODE FEATURE IN USE.
7. NORMALLY CLOSED CONTACT PROGRAMMED AS RELAY B VIA DIGITRIP FRONT PANEL. (BLOCK CLOSE CONTACT)
8. NORMALLY OPEN CONTACT PROGRAMMED AS RELAY C VIA DIGITRIP FRONT PANEL. (LATCHING CONTACT)
9. ON 4-POLE BREAKERS (ACTUALLY 8 PHYSICAL POLES), THE NEUTRAL CURRENT SENSORS ARE LOCATED WITHIN THE BREAKER FRAME. THE SECONDARY CONTACTS B-4, B-5, ARE NOT WIRED OUT.
10. MOTOR OPERATOR SWITCH SHOWN WITH BREAKER CLOSING SPRING DISCHARGED.
11. FOUR POINT SOCKET USE HERE.
12. SECOND SHUNT TRIP MAY BE INSTALLED (USING A-7, A-8 CONTACTS) IN PLACE OF UVR. THIRD AUX SWITCH NOT AVAILABLE WITH SECOND SHUNT TRIP.
13. ONLY ONE LATCH CHECK SWITCH MAY BE INSTALLED. USE OF CUSTOMER ACCESSIBLE LATCH CHECK SWITCH (B-29, B-30) IN SERIES WITH SPRING RELEASE DEFEATS ANTI-PUMP FUNCTION AND IS NOT RECOMMENDED. SEE NOTE 3 FOR SPRING RELEASE LATCH CHECK SWITCH.
14. THE OTS (OVERCURRENT TRIP SWITCHES) WILL OPERATE DIRECTLY FROM THE DIGITRIP DRIVING THE TA (TRIP ACTUATOR) TO TRIP THE CIRCUIT BREAKER. THE OTS REQUIRES A MANUAL LOCAL RESET VIA RED BUTTON DEPRESSION.
15. FOR CIRCUIT BREAKERS BUILT AFTER JULY 2006 AND DIGITRIP 1150 UNITS OF FIRMWARE REV 2006c10a1 OR GREATER, THE MAINTENANCE MODE FEATURE (ARMS) IS SUPPLIED. THE REVERSE POWER DESELECTIONS FRONT PANEL PROGRAMMABLE ONLY.

Figure 3-34 Connection Diagram for Double-wide Frame (except MDSX) with Digtirip 1150 with ABCABC Configuration

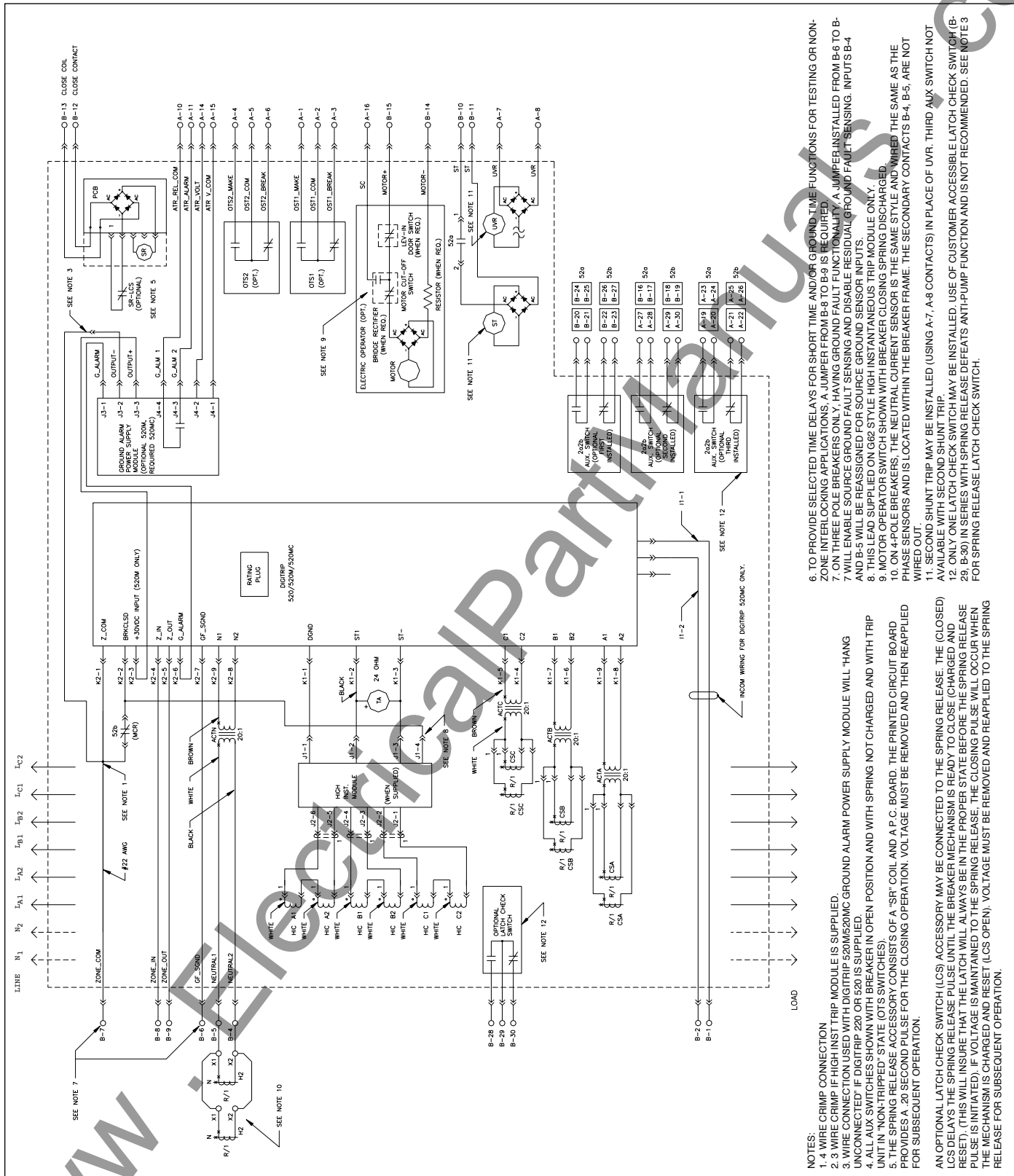

Figure 3-35 Connection Diagram for Double-wide Frame (except MDSX) with Digitrip 520 and 520M with AABCC Configuration

- NOTES:
- 4 WIRE CRIMP CONNECTION
 - 3 WIRE CRIMP IF HIGH INST TRIP MODULE IS SUPPLIED.
 - WIRE CONNECTION USED WITH DIGITRIP 520/520MC GROUND ALARM POWER SUPPLY MODULE WILL "HANG UNCONNECTED" IF DIGITRIP 220 OR 520 IS SUPPLIED.
 - ALL AUX SWITCHES SHOWN WITH BREAKER IN OPEN POSITION AND WITH SPRING NOT CHARGED AND WITH TRIP UNIT IN "NON-TRIPPED" STATE (OTS SWITCHES).
 - THE SPRING RELEASE ACCESSORY CONSISTS OF A "SR" COIL AND A P.C. BOARD. THE PRINTED CIRCUIT BOARD PROVIDES A .20 SECOND PULSE FOR THE CLOSING OPERATION. VOLTAGE MUST BE REMOVED AND THEN REAPPLIED FOR SUBSEQUENT OPERATION.
 - AN OPTIONAL LATCH CHECK SWITCH (LCS) ACCESSORY MAY BE CONNECTED TO THE SPRING RELEASE. THE (CLOSED) LCS DELAYS THE SPRING RELEASE PULSE UNTIL THE BREAKER MECHANISM IS READY TO CLOSE (CHARGED AND RESET). (THIS WILL INSURE THAT THE LATCH WILL ALWAYS BE IN THE PROPER STATE BEFORE THE SPRING RELEASE PULSE IS INITIATED). IF VOLTAGE IS MAINTAINED TO THE SPRING RELEASE, THE CLOSING PULSE WILL OCCUR WHEN THE MECHANISM IS CHARGED AND RESET (LCS OPEN). VOLTAGE MUST BE REMOVED AND REAPPLIED TO THE SPRING RELEASE FOR SUBSEQUENT OPERATION.
 - TO PROVIDE SELECTED TIME DELAYS FOR SHORT TIME AND/OR GROUND TIME FUNCTIONS FOR TESTING OR NON-ZONE INTERLOCKING APPLICATIONS, A JUMPER FROM B-8 TO B-9 IS REQUIRED.
 - ON THREE POLE BREAKERS ONLY, HAVING GROUND FAULT FUNCTIONALITY, A JUMPER INSTALLED FROM B-6 TO B-7 WILL ENABLE SOURCE GROUND FAULT SENSING AND DISABLE RESIDUAL GROUND FAULT SENSING. INPUTS B-4 AND B-5 WILL BE REASSIGNED FOR SOURCE GROUND SENSOR INPUTS.
 - THIS LEAD SUPPLIED ON G62 STYLE HIGH INSTANTANEOUS TRIP MODULE ONLY.
 - MOTOR OPERATOR SWITCH SHOWN WITH BREAKER CLOSING SPRING DISCHARGED.
 - ON 4-POLE BREAKERS, THE NEUTRAL CURRENT SENSOR IS THE SAME STYLE AND WIRED THE SAME AS THE PHASE SENSORS AND IS LOCATED WITHIN THE BREAKER FRAME. THE SECONDARY CONTACTS B-4, B-5, ARE NOT WIRED OUT.
 - SECOND SHUNT TRIP MAY BE INSTALLED (USING A-7, A-8 CONTACTS) IN PLACE OF UVR. THIRD AUX SWITCH NOT AVAILABLE WITH SECOND SHUNT TRIP.
 - ONLY ONE LATCH CHECK SWITCH MAY BE INSTALLED. USE OF CUSTOMER ACCESSIBLE LATCH CHECK SWITCH (B-29, B-30) IN SERIES WITH SPRING RELEASE DEFEATS ANTI-PUMP FUNCTION AND IS NOT RECOMMENDED. SEE NOTE 3 FOR SPRING RELEASE LATCH CHECK SWITCH.

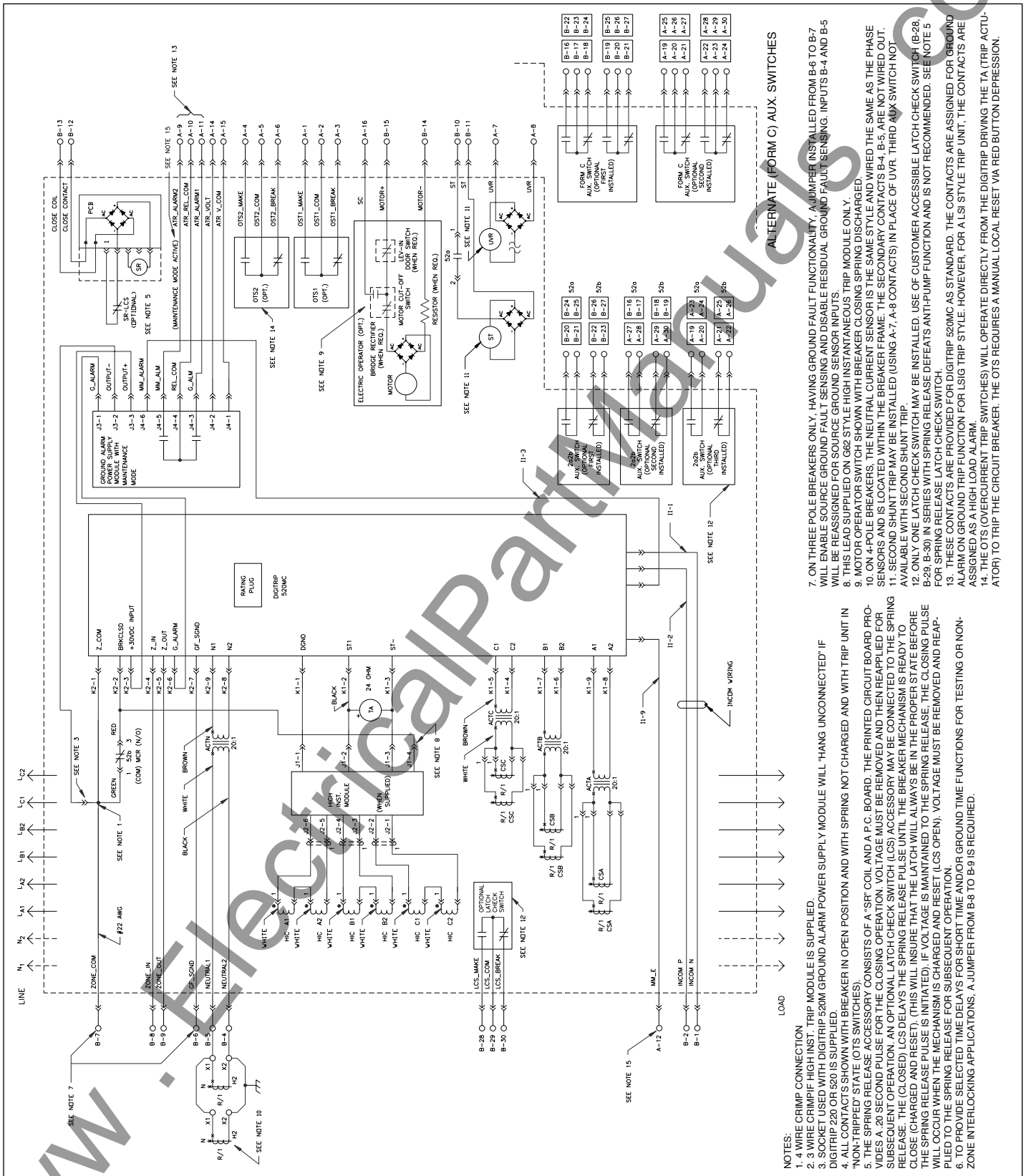

Figure 3-36 Connection Diagram for Double-wide Frame (except MDSX) with Digitrip 520MC with AABCC Configuration

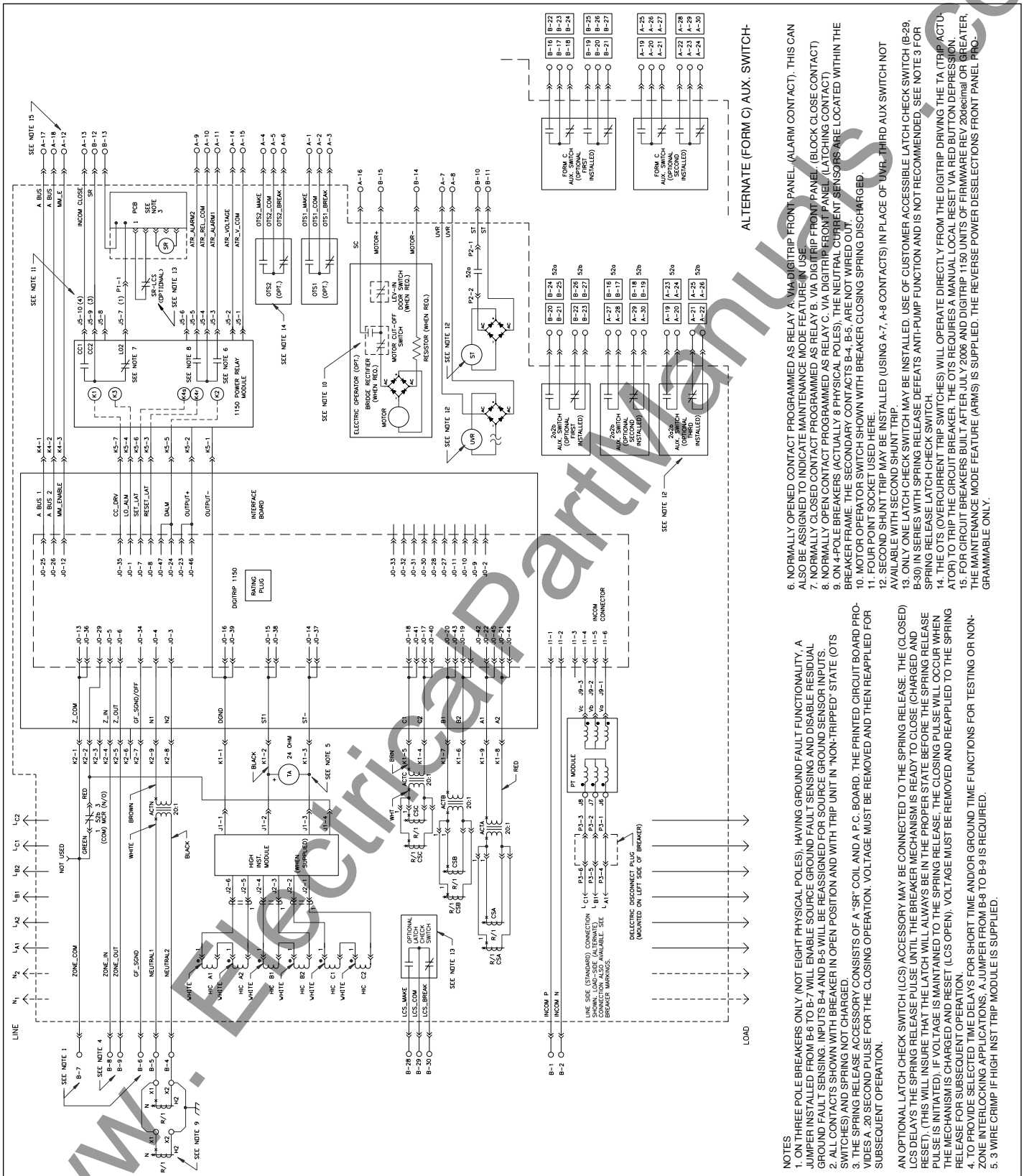

Figure 3-37 Connection Diagram for Double-wide Frame (except MDSX) with Digitrip 1150 with AABCC Configuration

NOTES

1. ON THREE POLE BREAKERS ONLY (NOT EIGHT PHYSICAL POLES), HAVING GROUND FAULT FUNCTIONALITY, A JUMPER INSTALLED FROM B-6 TO B-7 WILL ENABLE SOURCE GROUND FAULT SENSING AND DISABLE RESIDUAL GROUND FAULT SENSING. INPUTS B-4 AND B-5 WILL BE REASSIGNED FOR SOURCE SENSOR INPUTS.
2. ALL CONTACTS SHOWN WITH BREAKER IN OPEN POSITION AND WITH TRIP UNIT IN "NON-TRIPPED" STATE (OTS SWITCHES) AND SPRING NOT CHARGED.
3. THE SPRING RELEASE ACCESSORY CONSISTS OF A "SR" COIL AND A P.C. BOARD. THE PRINTED CIRCUIT BOARD PROVIDES A .20 SECOND PULSE FOR THE CLOSING OPERATION. VOLTAGE MUST BE REMOVED AND THEN REAPPLIED FOR SUBSEQUENT OPERATION.
4. TO PROVIDE SELECTING TIME DELAYS FOR SHORT TIME AND/OR GROUND TIME FUNCTIONS FOR TESTING OR NON-ZONE INTERLOCKING APPLICATIONS, A JUMPER FROM B-8 TO B-9 IS REQUIRED.
5. 3 WIRE CRIMP IF HIGH INST TRIP MODULE IS SUPPLIED.

ALTERNATE (FORM C) AUX. SWITCH-

6. NORMALLY OPENED CONTACT PROGRAMMED AS RELAY A VIA DIGITRIP FRONT PANEL (ALARM CONTACT). THIS CAN ALSO BE ASSIGNED TO INDICATE MAINTENANCE MODE FEATURE IN USE.
7. NORMALLY CLOSED CONTACT PROGRAMMED AS RELAY B VIA DIGITRIP FRONT PANEL (BLOCK CLOSE CONTACT)
8. NORMALLY OPEN CONTACT PROGRAMMED AS RELAY C VIA DIGITRIP FRONT PANEL (LATCHING CONTACT)
9. ON 4-POLE BREAKERS (ACTUALLY 8 PHYSICAL POLES), THE NEUTRAL CURRENT SENSORS ARE LOCATED WITHIN THE BREAKER FRAME. THE SECONDARY CONTACTS B-4, B-5, ARE NOT WIRED OUT.
10. MOTOR OPERATION SWITCH SHOWN WITH BREAKER CLOSING SPRING DISCHARGED.
11. FOUR POINT SOCKET USED HERE.
12. SECOND SHUNT TRIP MAY BE INSTALLED (USING A-7, A-8 CONTACTS) IN PLACE OF UVR. THIRD AUX SWITCH NOT AVAILABLE WITH SECOND SHUNT TRIP.
13. ONLY ONE LATCH CHECK SWITCH MAY BE INSTALLED. USE OF CUSTOMER ACCESSIBLE LATCH CHECK SWITCH (B-29, B-30) IN SERIES WITH SPRING RELEASE DEFERS ANTI-PUMP FUNCTION AND IS NOT RECOMMENDED. SEE NOTE 3 FOR SPRING RELEASE LATCH CHECK SWITCH.
14. THE OTS (OVERCURRENT TRIP SWITCHES) WILL OPERATE DIRECTLY FROM THE DIGITRIP DRIVING THE TA (TRIP ACTUATOR) TO TRIP THE CIRCUIT BREAKER. THE OTS REQUIRES A MANUAL LOCAL RESET VIA RED BUTTON DEPRESSION.
15. FOR CIRCUIT BREAKERS BUILT AFTER JULY 2006 AND DIGITRIP 1150 UNITS OF FIRMWARE REV 2.006 OR GREATER, THE MAINTENANCE MODE FEATURE (ARMS) IS SUPPLIED. THE REVERSE POWER DESELECTIONS FRONT PANEL PROG. GRAMMABLE ONLY.

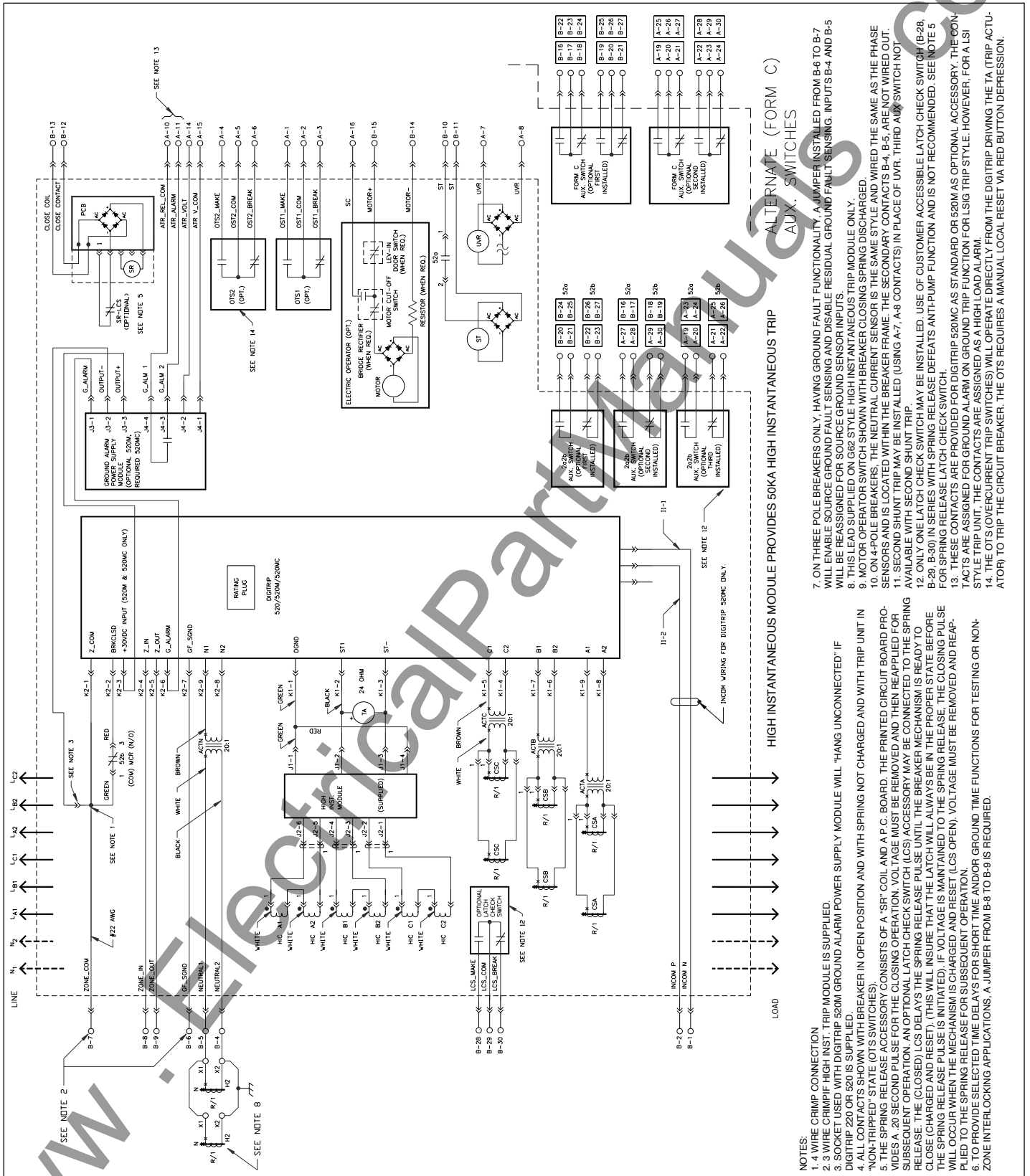

Figure 3-38 Connection Diagram for MDSX Double-wide Frame with Digitrip 520 and 520M with ABCABC Configuration

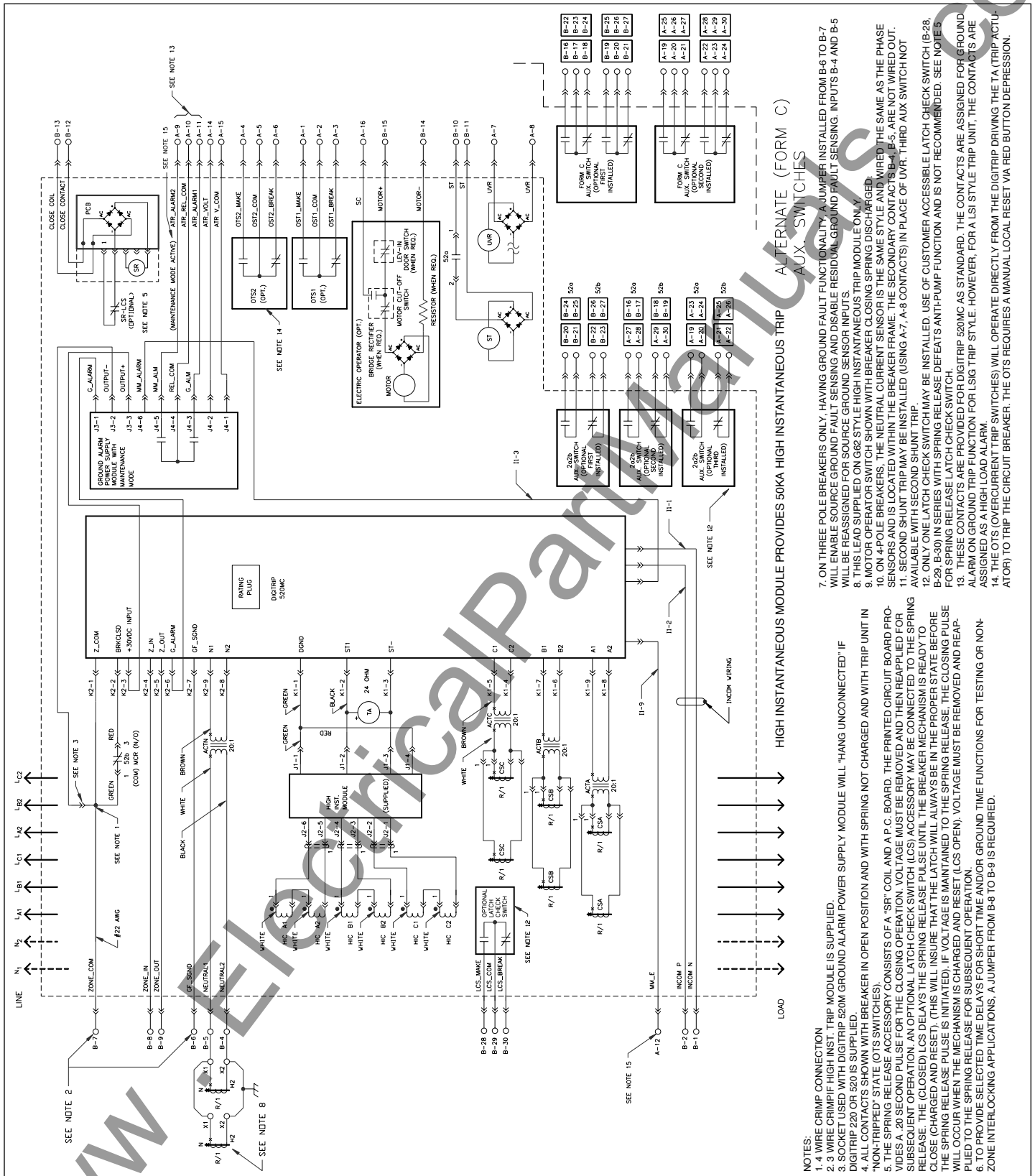

Figure 3-39 Connection Diagram for MDSX Double-wide Frame with Digtrip 520MC with ABCABC Configuration

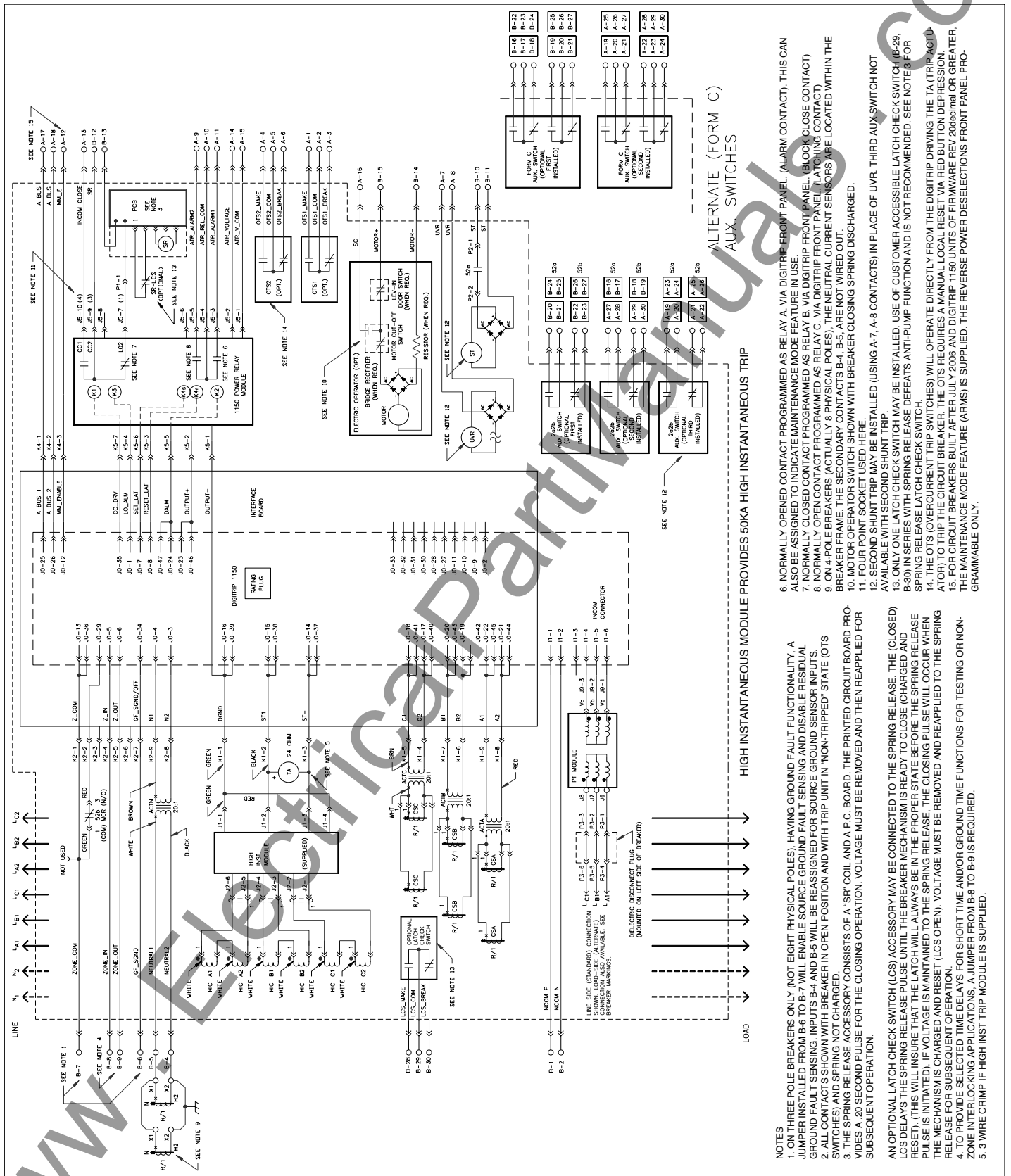
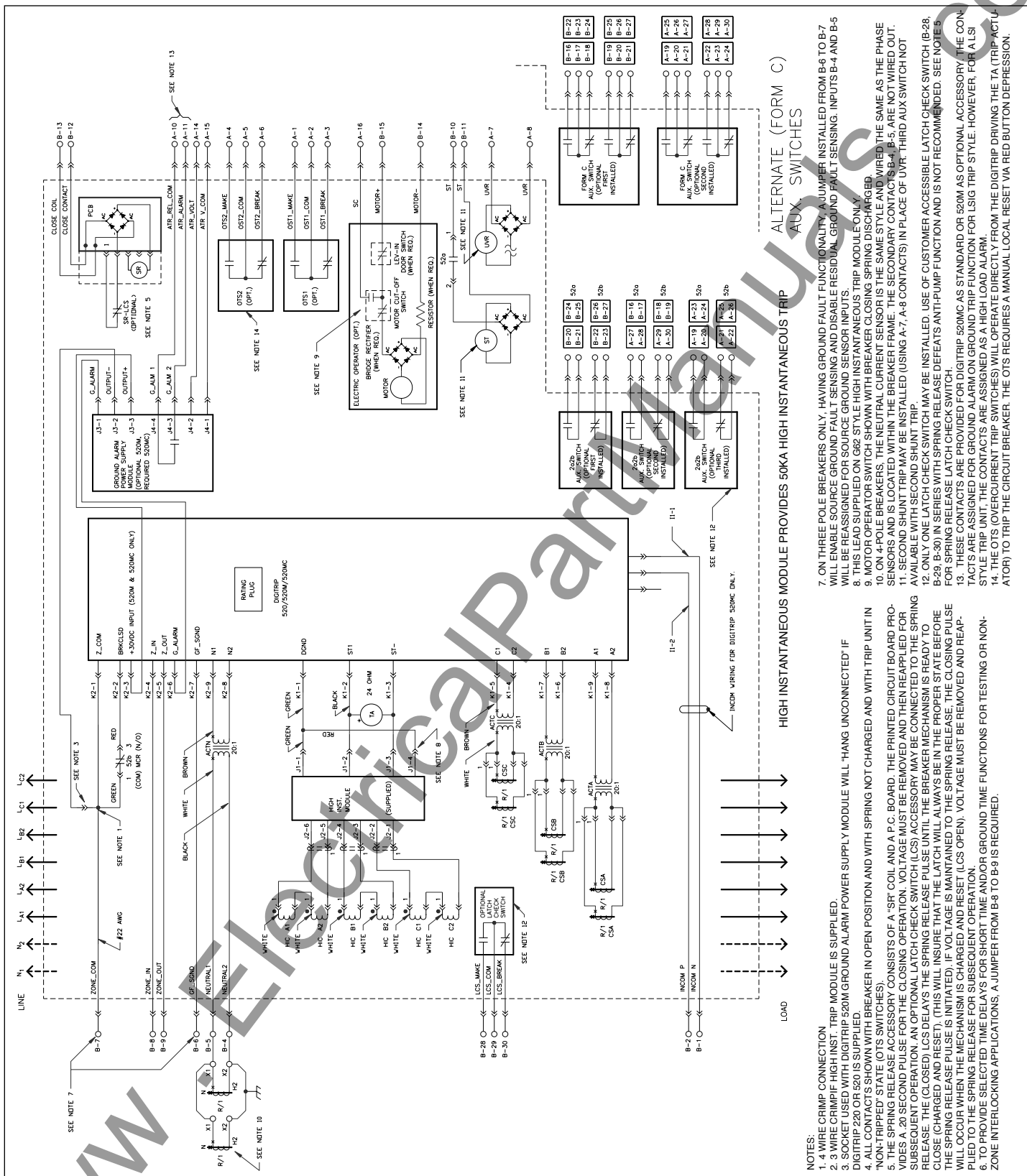

Figure 3-40 Connection Diagram for MDSX Double-wide Frame with Digitrip 1150 with ABC/ABC Configuration



ALTERNATE (FORM C) AUX SWITCHES

HIGH INSTANTANEOUS MODULE PROVIDES 50KA HIGH INSTANTANEOUS TRIP

- NOTES:
- 4 WIRE CRIMP CONNECTION
 - 3 SOCKET USED WITH DIGITRIP 520M GROUND ALARM POWER SUPPLY MODULE WILL "HANG UNCONNECTED" IF DIGITRIP 220 OR 520 IS SUPPLIED.
 - SOCKET SHOWN WITH BREAKER IN OPEN POSITION AND WITH SPRING NOT CHARGED AND WITH TRIP UNIT IN NON-TRIP STATE (O'S SWITCHES).
 - ALL CONTACTS SHOWN WITH BREAKER CLOSING SPRING DISCHARGED.
 - THE SPRING RELEASE ACCESSORY (LCS) ACCESSORY MAY BE CONNECTED TO THE SPRING RELEASE. THE (CLOSED) LCS DELAYS THE SPRING RELEASE PULSE UNTIL THE BREAKER MECHANISM IS HEAD TO CLOSE (CHARGED AND RESET). THIS WILL INSURE THAT THE LATCH WILL ALWAYS BE IN THE PROPER STATE BEFORE THE SPRING RELEASE PULSE IS INITIATED. IF VOLTAGE IS MAINTAINED TO THE SPRING RELEASE, THE CLOSING PULSE WILL OCCUR WHEN THE MECHANISM IS CHARGED AND RESET (LCS OPEN). VOLTAGE MUST BE REMOVED AND REAPPLIED TO THE SPRING RELEASE FOR SUBSEQUENT OPERATION.
 - TO PROVIDE SELECTED TIME DELAYS FOR SHORT TIME AND/OR GROUND TIME FUNCTIONS FOR TESTING OR NON-ZONE INTERLOCKING APPLICATIONS, A JUMPER FROM B-8 TO B-9 IS REQUIRED.
 - ON THREE POLE BREAKERS ONLY. HAVING GROUND FAULT FUNCTIONALITY, A JUMPER INSTALLED FROM B-6 TO B-7 WILL ENABLE SOURCE GROUND FAULT SENSING AND DISABLE RESIDUAL GROUND FAULT SENSING. INPUTS B-4 AND B-5 WILL BE REASSIGNED FOR SOURCE GROUND SENSOR INPUTS.
 - THIS LEAD SUPPLIED FOR 602 STYLE HIGH INSTANTANEOUS TRIP MODULE ONLY.
 - MOTOR OPERATOR SWITCH SHOWN WITH BREAKER CLOSING SPRING DISCHARGED.
 - ON 4-POLE BREAKERS, THE NEUTRAL CURRENT SENSOR IS THE SAME STYLE AND WIRED THE SAME AS THE PHASE SENSORS AND IS LOCATED WITHIN THE BREAKER FRAME. THE SECONDARY CONTACTS B-4-B-5, ARE NOT WIRED OUT.
 - SECOND SHUNT TRIP MAY BE INSTALLED (USING A-7, A-8 CONTACTS) IN PLACE OF OVR. THIRD AUX SWITCH NOT AVAILABLE WITH SECOND SHUNT TRIP.
 - ONLY ONE LATCH CHECK SWITCH MAY BE INSTALLED. USE OF CUSTOMER ACCESSIBLE LATCH CHECK SWITCH (B-28, B-29, B-30) IN SERIES WITH SPRING RELEASE DEFEATS ANTI-PUMP FUNCTION AND IS NOT RECOMMENDED. SEE NOTE 5.
 - THESE CONTACTS ARE PROVIDED FOR DIGITRIP 520MCS AS STANDARD OR 520M AS OPTIONAL ACCESSORY. THE CONTACTS ARE ASSIGNED FOR GROUND ALARM ON GROUND TRIP FUNCTION FOR LSIG TRIP STYLE. HOWEVER, FOR A LSI STYLE TRIP UNIT, THE CONTACTS ARE ASSIGNED AS A HIGH LOAD ALARM.
 - THE OTS (OVERCURRENT TRIP SWITCHES) WILL OPERATE DIRECTLY FROM THE DIGITRIP DRIVING THE TA (TRIP ACTUATOR) TO TRIP THE CIRCUIT BREAKER. THE OTS REQUIRES A MANUAL LOCAL RESET VIA RED BUTTON DEPRESSION.

Figure 3-41 Connection Diagram for MDSX Double-wide Frame with Digtrip 520 and 520M with AABCC Configuration

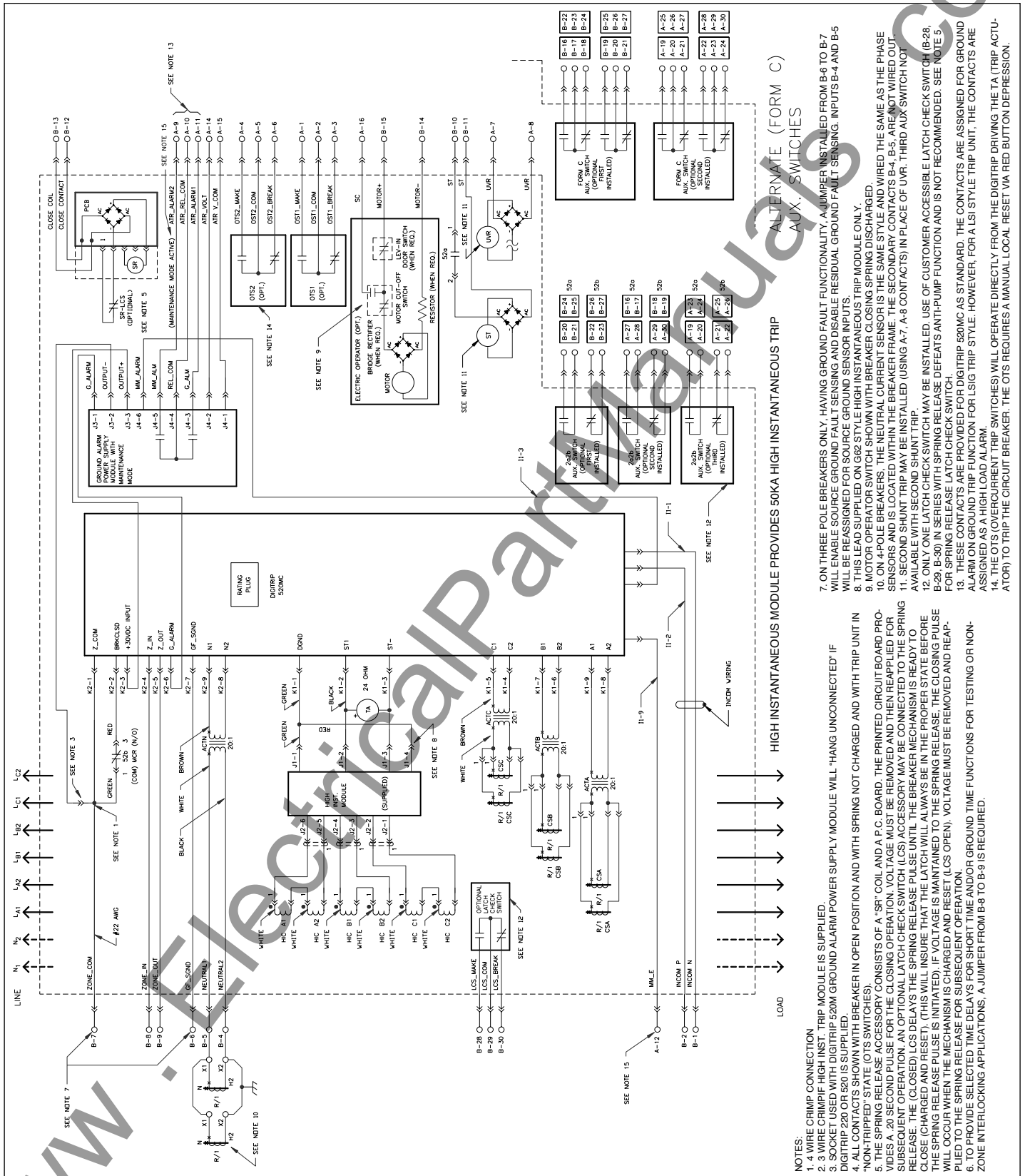

Figure 3-42 Connection Diagram for MDSX Double-wide Frame with Digitrip 520MC with AABCC Configuration

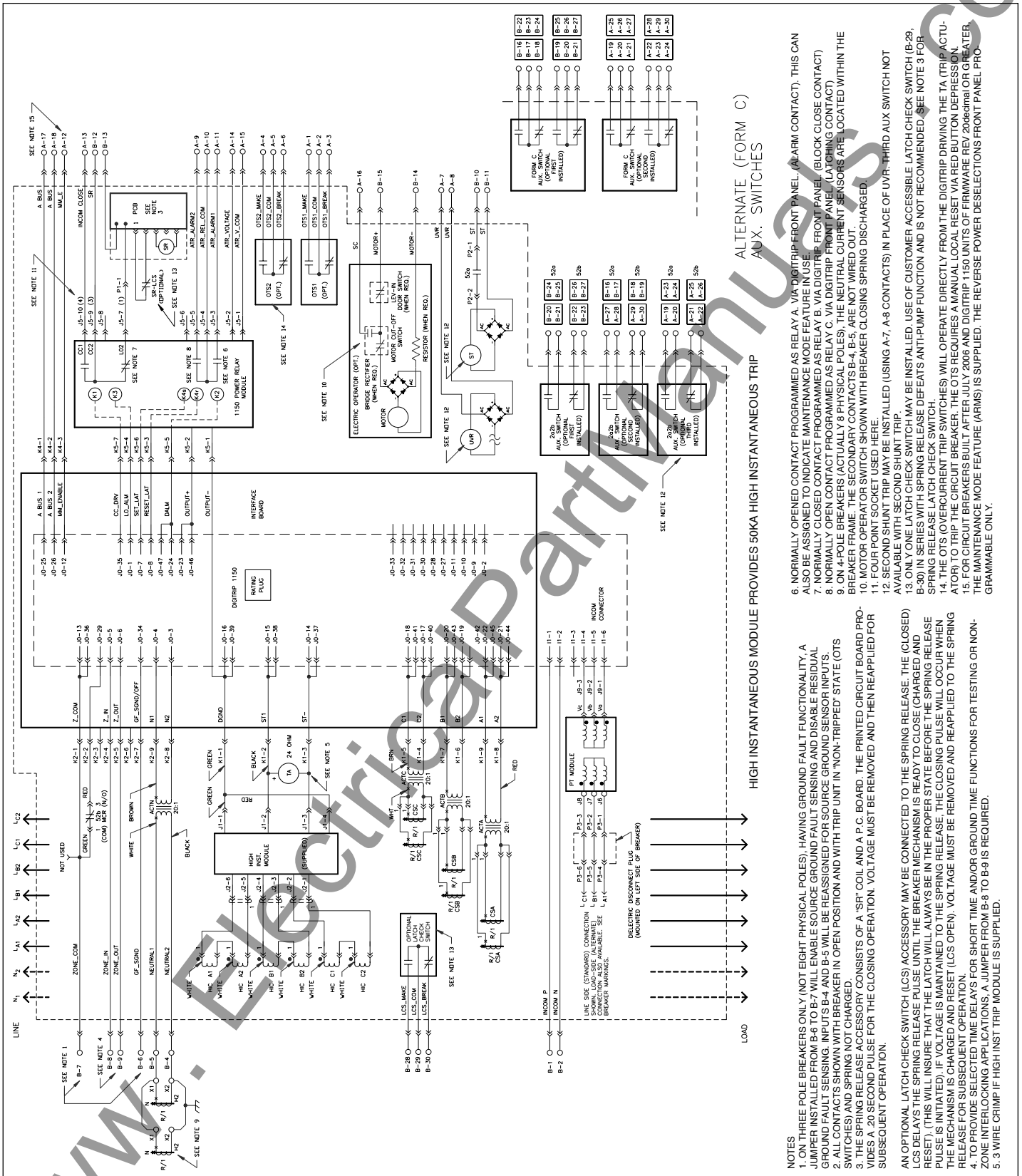

Figure 3-43 Connection Diagram for MDSX Double-wide Frame with Digitrip 1150 with AABCC Configuration

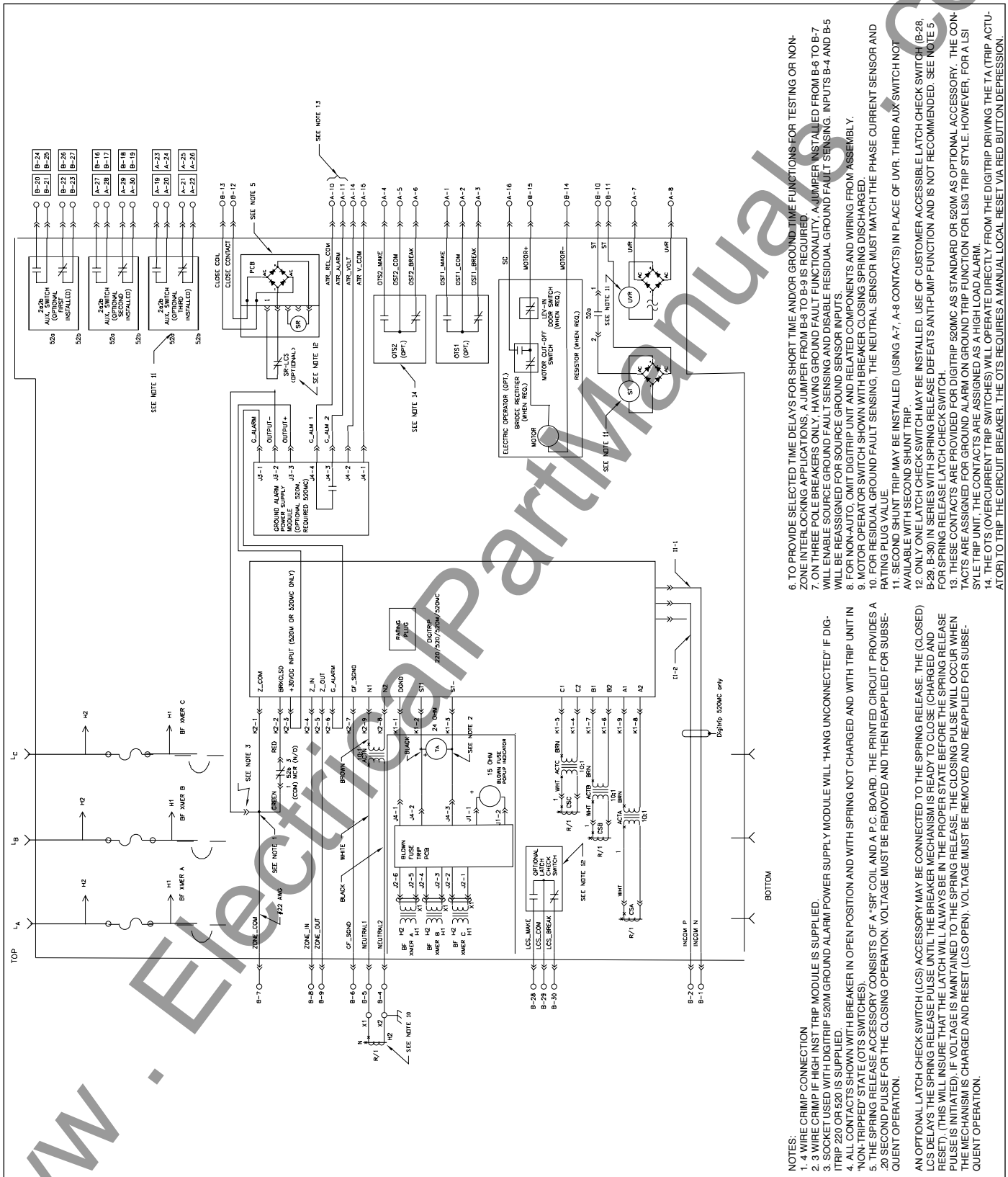

Figure 3-44 Magnum DSL Connection Diagram with Blown Fuse Trip Digitrip 520 and 520M

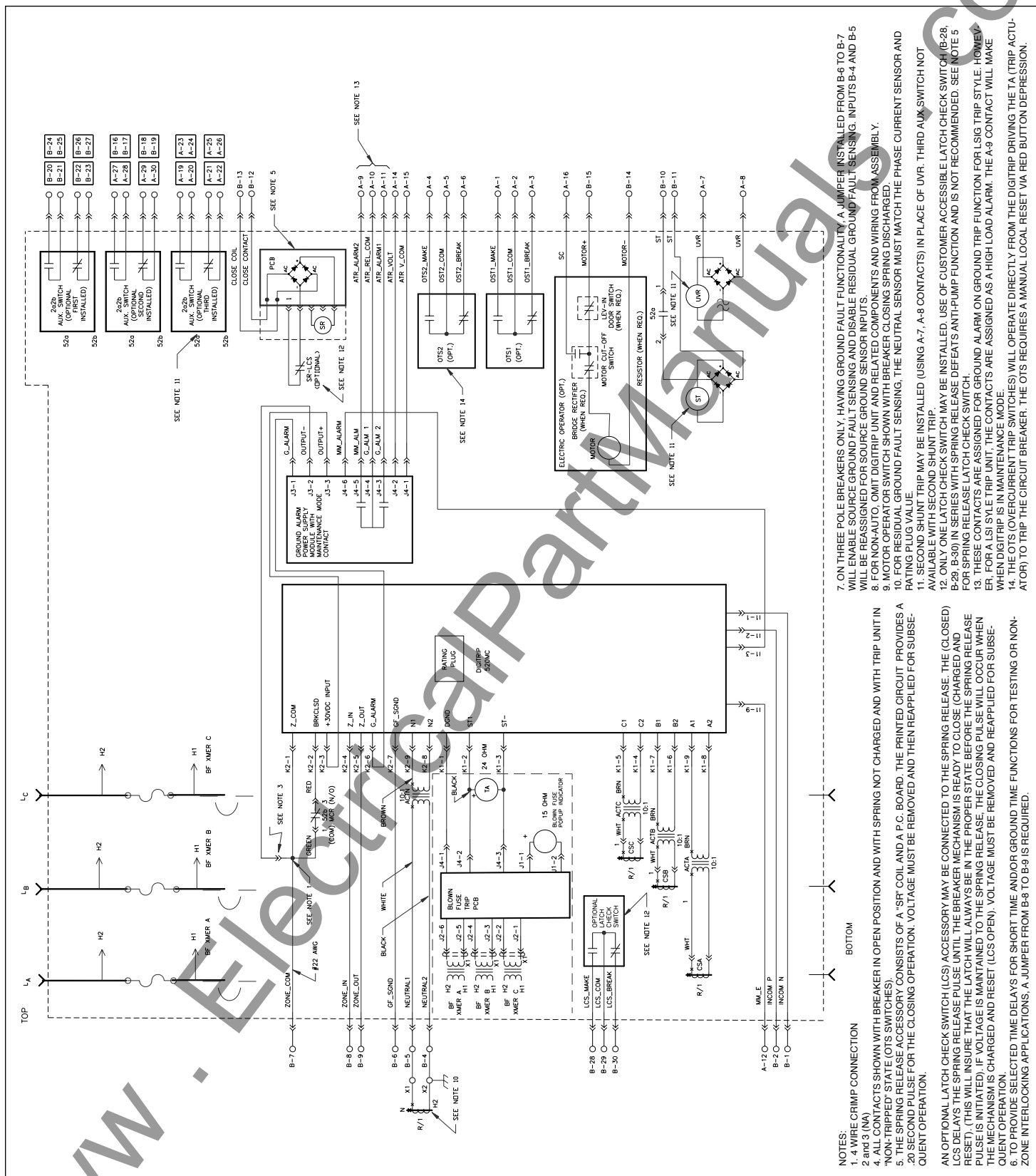

Figure 3-45 Magnum DSL Connection Diagram with Blown Fuse Trip Digitrip 520MC

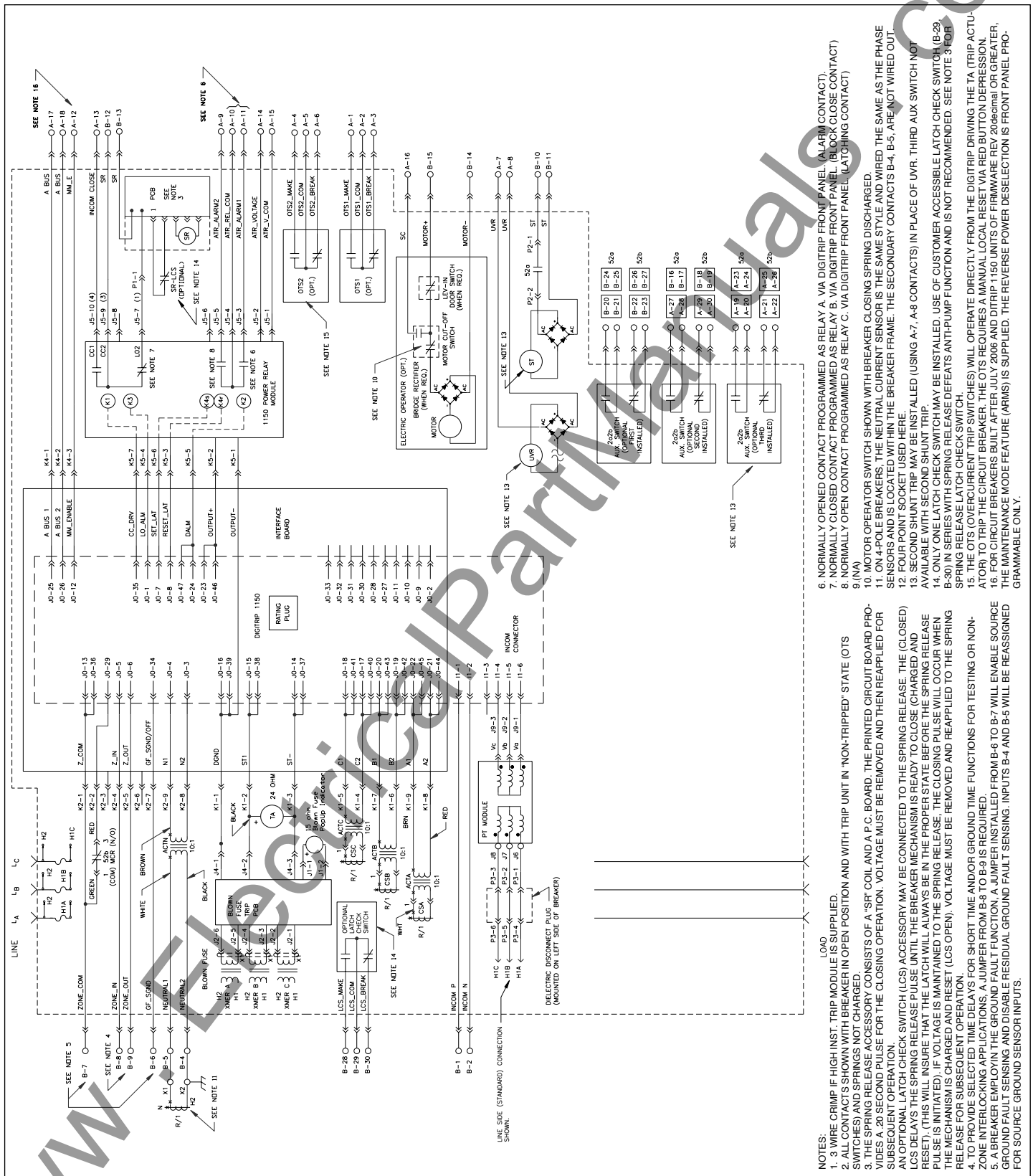

Figure 3-46 Magnum DSL Connection Diagram with Blown Fuse Trip Digtrip 1150

- NOTES:
- 3 WIRE CRIMP IF HIGH INST. TRIP MODULE IS SUPPLIED.
 - ALL CONTACTS SHOWN WITH BREAKER IN OPEN POSITION AND WITH TRIP UNIT IN "NON-TRIPPED" STATE (OTS SWITCHES) AND SPRINGS NOT CHARGED.
 - THE SPRING RELEASE ACCESSORY CONSISTS OF A "SR" COIL AND A P.C. BOARD. THE PRINTED CIRCUIT BOARD PROVIDES A .20 SECOND PULSE FOR THE CLOSING OPERATION. VOLTAGE MUST BE REMOVED AND THEN REAPPLIED FOR SUBSEQUENT OPERATION.
 - AN OPTIONAL LATCH CHECK SWITCH (LCS) ACCESSORY MAY BE CONNECTED TO THE SPRING RELEASE. THE (CLOSED) LCS DELAYS THE SPRING RELEASE PULSE UNTIL THE BREAKER MECHANISM IS READY TO CLOSE (CHARGED AND RESET). (THIS WILL INSURE THAT THE LATCH WILL ALWAYS BE IN THE PROPER STATE BEFORE THE SPRING RELEASE PULSE IS INITIATED). IF VOLTAGE IS MAINTAINED TO THE SPRING RELEASE, THE CLOSING PULSE WILL OCCUR WHEN THE MECHANISM IS CHARGED AND RESET (LCS OPEN). VOLTAGE MUST BE REMOVED AND REAPPLIED TO THE SPRING RELEASE FOR SUBSEQUENT OPERATION.
 - TO PROVIDE SELECTED TIME DELAYS FOR SHORT TIME AND/OR GROUND TIME FUNCTIONS FOR TESTING OR NON-ZONE INTERLOCKING APPLICATIONS, A JUMPER FROM B-6 TO B-7 WILL ENABLE SOURCE
 - A BREAKER EMPLOYING THE GROUND FAULT FUNCTION, A JUMPER INSTALLED FROM B-8 TO B-9 IS REQUIRED.
 - GROUND FAULT SENSING AND DISABLE RESIDUAL GROUND FAULT SENSING. INPUTS B-4 AND B-5 WILL BE REASSIGNED FOR SOURCE GROUND SENSOR INPUTS.

6. NORMALLY OPENED CONTACT PROGRAMMED AS RELAY A VIA DIGITRIP FRONT PANEL (ALARM CONTACT).
7. NORMALLY CLOSED CONTACT PROGRAMMED AS RELAY B VIA DIGITRIP FRONT PANEL (BLOCK CLOSE CONTACT)
8. NORMALLY OPEN CONTACT PROGRAMMED AS RELAY C VIA DIGITRIP FRONT PANEL (LATCHING CONTACT)
- 9.(NA)
10. MOTOR OPERATOR SWITCH SHOWN WITH BREAKER CLOSING SPRING DISCHARGED.
11. ON 4-POLE BREAKERS, THE NEUTRAL CURRENT SENSOR IS THE SAME STYLE AND WIRED THE SAME AS THE PHASE SENSORS AND IS LOCATED WITHIN THE BREAKER FRAME. THE SECONDARY CONTACTS B-4, B-5, ARE NOT WIRED OUT SECOND SHUNT TRIP MAY BE INSTALLED (USING A-7, A-8 CONTACTS) IN PLACE OF UVR. THIRD AUX SWITCH NOT AVAILABLE WITH SECOND SHUNT TRIP.
12. FOUR POINT SOCKET USED HERE.
13. SECOND SHUNT TRIP MAY BE INSTALLED (USING A-7, A-8 CONTACTS) IN PLACE OF UVR. THIRD AUX SWITCH NOT AVAILABLE WITH SECOND SHUNT TRIP.
14. ONLY ONE LATCH CHECK SWITCH MAY BE INSTALLED. USE OF CUSTOMER ACCESSIBLE LATCH CHECK SWITCH (B-28, B-30) IN SERIES WITH SPRING RELEASE DEFEATS ANTI-PUMP FUNCTION AND IS NOT RECOMMENDED. SEE NOTE 3 FOR SPRING RELEASE LATCH CHECK SWITCH.
15. THE OTS (OVERCURRENT TRIP SWITCHES) WILL OPERATE DIRECTLY FROM THE DIGITRIP DRIVING THE TA (TRIP ACTUATOR) TO TRIP THE CIRCUIT BREAKER. THE OTS REQUIRES A MANUAL LOCAL RESET VIA RED BUTTON DEPRESSION.
16. FOR CIRCUIT BREAKERS BUILT AFTER JULY 2006 AND DITRIP 1150 UNITS OF FIRMWARE REV 20060101 OR GREATER, THE MAINTENANCE MODE FEATURE (ARMS) IS SUPPLIED. THE REVERSE POWER DEPRESSION IS FRONT PANEL PROGRAMMABLE ONLY.

www.ElectricalPartManuals.com

3-8 ACCESSORY DEVICES

A variety of accessory devices are available for use with Magnum circuit breakers. Unless otherwise stated, they are all considered optional devices in the sense that they are not provided as standard on a manually operated circuit breaker. Available accessories are identified here and discussed in general terms. For more detailed information and/or installation instructions, refer to individual instruction leaflets dedicated to the accessories.

Magnum circuit breaker accessories are designed to fit all frame sizes. The accessories fall into one of three categories:

- Plug-in electrical
- Internal electrical
- Mechanical

3-8.1 PLUG-IN ELECTRICAL ACCESSORIES

There are four Magnum Plug-In electrical accessories. Three can be viewed for identification by name and rating through viewing windows located in the right front of the circuit breaker (Figure 3-47). All four are plug-in type and can be factory installed or field installed using a UL listed kit.

The four Plug-In accessories are:

- Shunt Trip (ST)
- Spring Release (SR)
- Undervoltage Release (UVR)
- Auxiliary Switch

Shunt Trip - The shunt trip is an optional device on circuit breakers (Figures 3-48 and 3-49). It opens the circuit breaker instantaneously when its coil is energized by a voltage input (Table 3.3). A total of two shunt trips can be mounted on a Magnum circuit breaker.

Table 3.3 Shunt Trip Ratings

Control Voltages	Operational Voltage Range 70-110%	Inrush Power Consumption ^①	Opening Time (ms)
24 Vdc	17-26 Vdc	250 W	35
48 Vdc	34-53 Vdc	250 W	35
110-125 Vdc	77-138 Vdc	450 W	35
220-250 Vdc	154-275 Vdc	450 W	35
110-127 Vac	77-140 Vac	450 VA	35
208-240 Vac	146-264 Vac	450 VA	35

^① Required for less than 35 ms

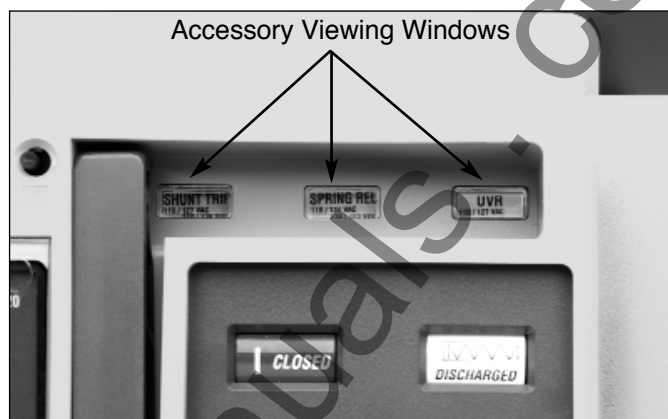

Figure 3-47 Through-the-Window Electrical Accessories



Figure 3-48 Shunt Trip with Cutoff Switch



Figure 3-49 Shunt Trip Switch Installed

Spring Release - The spring release is an optional device (Figure 3-50). It remotely closes the circuit breaker when the coil is energized by a voltage input (Table 3.4). The closing spring must be fully charged and the trip latch reset (not held in the tripped position) for the SR to operate. If these two conditions are not met the close signal will be ignored until it is removed and re-applied.

An optional Latch Check Switch (LCS) can be installed to indicate when the circuit breaker is “ready to close”. Two versions of the LCS are available.

The Latch Check Switch wired to the Spring Release will not permit activation of the Spring Release until the circuit breaker is fully charged and the trip latch is reset (Figure 3-50). If power is applied and maintained to the Spring Release, an activation will occur when the circuit breaker is “ready to close”.

The Latch Check Switch for Remote Indication consists of 1 Form C contact wired to the circuit breaker secondary contacts for integration into external control schemes. Note that wiring the LCS for Remote Indication directly in series with the SR accessory is not recommended as this will override the “anti-pump” feature of the electrical charging/closing system.

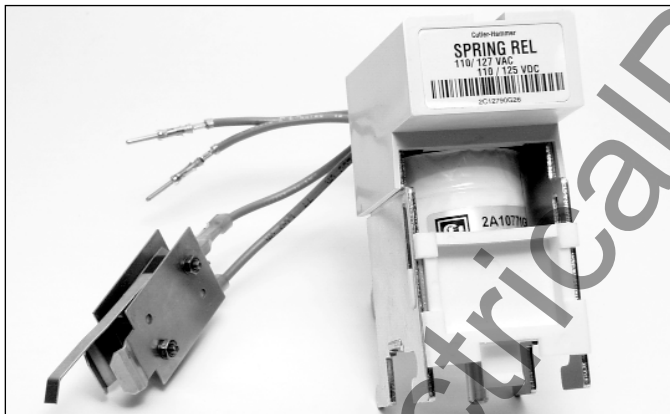

Figure 3-50 Spring Release with Optional Latch Switch

Table 3.4 Spring Release Ratings

Control Voltages	Operational Voltage Range 70-110%	Inrush Power Consumption	Closing Time (ms)
24 Vdc	17-26 Vdc	250 W	40
48 Vdc	34-53 Vdc	250 W	40
110-125 Vdc	77-138 Vdc	450 W	40
220-250 Vdc	154-275 Vdc	450 W	40
110-127 Vac	77-140 Vac	450 VA	40
208-240 Vac	146-264 Vac	450 VA	40

① Required for less than 200 ms

Undervoltage Release - The undervoltage release is an optional device on both manually and electrically operated circuit breakers (Figure 3-51). It opens the circuit breaker when its supply voltage falls to between 35-60% of rated voltage. If the release is not energized to 85% of its supply voltage, the circuit breaker cannot be closed electrically or manually (Table 3.5).

Auxiliary Switch - An auxiliary switch is an optional device providing remote electrical indication if the circuit breaker is open or closed (Figure 3-53). Up to 3 auxiliary switches can be mounted in the circuit breaker. Each switch has 2 normally open (“a”) and 2 normally closed (“b”) contacts for a total of 12 available contacts (Table 3.6).

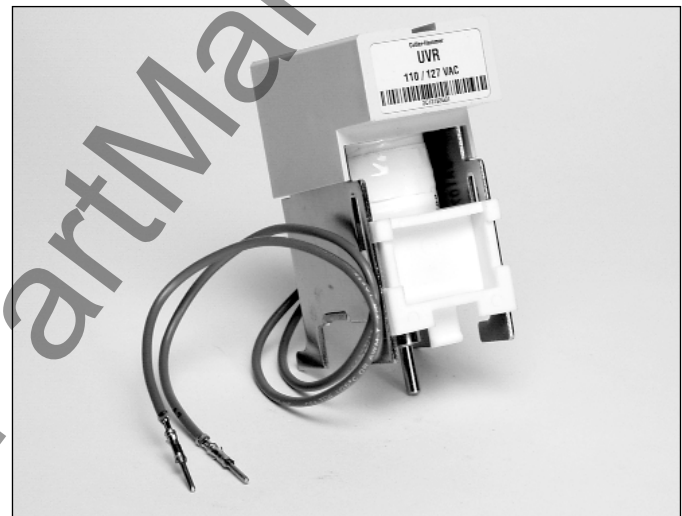

Figure 3-51 Undervoltage Release



Figure 3-52 Shunt Trip, Spring Release and Undervoltage Release Installed



Figure 3-53 Auxiliary Switch (2A/2B)

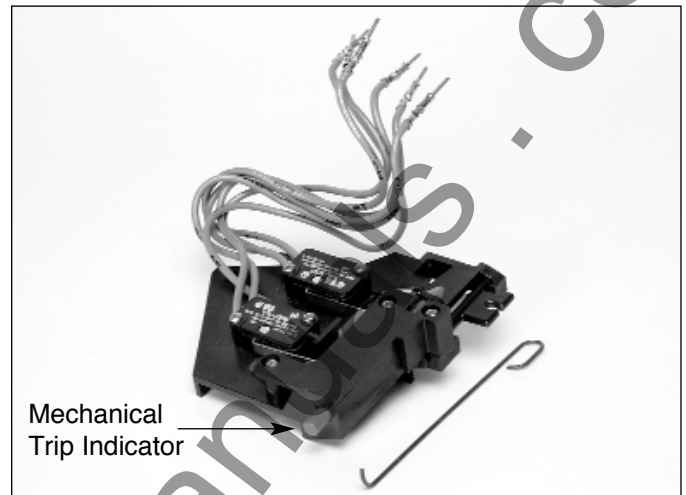

Figure 3-54 Mechanical Trip Indicator with Associated Overcurrent Trip Switch

Table 3.6 Auxiliary Switch, Overcurrent Trip Switch and Cell Switch Contact Ratings

Control Voltages	Contact Rating Inductive Load (amperes)
250 Vac	10
125 Vdc	0.5
250 Vdc	0.25

3-8.2 INTERNAL ELECTRICAL ACCESSORIES

Other electrical accessories are mounted inside the circuit breaker. They can be factory or site installed. There are two different internally mounted accessories:

- Overcurrent Trip Switch (Bell Alarm)
- Motor Operator

Overcurrent Trip Switch (Bell Alarm) - An overcurrent trip switch (bell alarm) is an optional device (Figure 3-54). It provides an electrical indication when a circuit

Table 3.5 Undervoltage Release

Control Voltages	Operational Voltage Range 85-110%	Dropout Volts 30-60%	① ② Inrush/Continuous Power Consumption	Opening Time (ms)
24 Vdc ①	20-26 Vdc	7-14 Vdc	250 W/18 W	70
32 Vdc ①	27-35 Vdc	10-19 Vdc	275 W/15 W	70
48 Vdc ①	41-53 Vdc	14-29 Vdc	275 W/18 W	70
110-125 Vdc ①	94-138 Vdc	33-75 Vdc	450 W/10 W	70
220-250 Vdc ①	187-275 Vdc	66-150 Vdc	450 W/10 W	70
110-127 Vac ②	94-140 Vac	33-76 Vac	450 VA/10 VA	70
208-240 Vac ②	177-264 Vac	62-144 Vac	400 VA/10 VA	70
380-415 Vac ②	323-457 Vac	114-249 Vac	480 VA/10 VA	70
480 Vac ②	408-528 Vac	144-288 Vac	400 VA/10 VA	70
600 Vac ②	510-660 Vac	180-360 Vac	400 VA/10 VA	70

① Required for 200 ms

② Required for 400 ms

breaker trips as a result of the trip unit reacting to an overcurrent condition. Opening as a result of a circuit breaker's manual open button, shunt trip or undervoltage release does **not** cause the overcurrent trip switch to operate. The overcurrent trip switch has (2a 2b) Form C contacts (Table 3.6).

The status of the contacts changes when the trip indicator pops out. This permits the switch to be used as an alarm or in conjunction with a spring release to block a subsequent remote electrical closing signal.

Motor Operator - A Motor operator is an electric motor assembly internally mounted in the circuit breaker (Figures 3-55 and 3-56). It charges the closing springs electrically for remote or local operation. The motor operator can be factory or site installed (Table 3.7).

To convert a manually operated circuit breaker to an electrically operated circuit breaker, a UL listed motor operator kit is available.

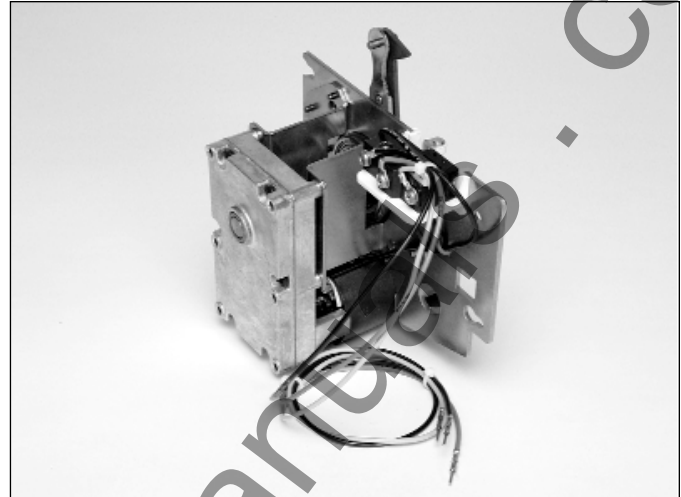

Figure 3-55 Motor Operator Kit

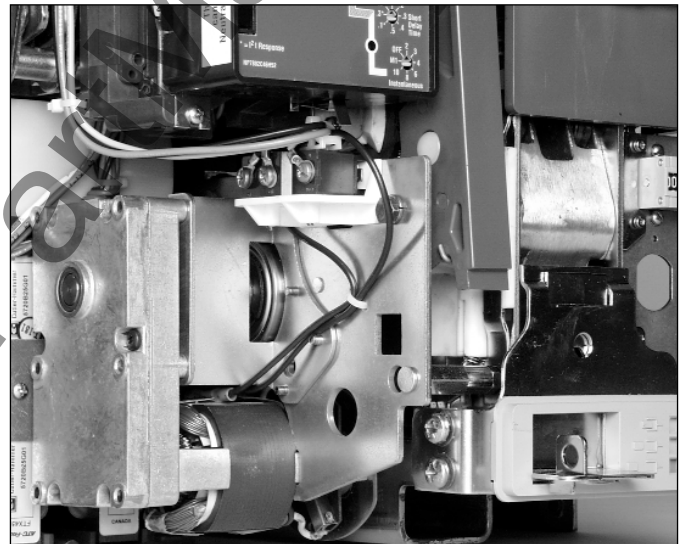

Figure 3-56 Motor Operator Installed in Narrow Frame Circuit Breaker

Table 3.7 Motor Operator

Control ① Voltages	Operational Voltage Range 85-110 %	Running Current (A. avg.)	Typical Inrush Current	Power Consumption (watts or VA)	Maximum Charging Time (seconds)
24 Vdc	20-26	12.0	300% of Running	300	5
48 Vdc	41-53	5.0	500% of Running	250	5
110-125 Vdc	94-138	2.0	600% of Running	250	5
220-250 Vdc	187-225	1.0	600% of Running	250	5
110-127 Vac	94-140	2.0	600% of Running	250	5
208-240 Vac	177-264	1.0	600% of Running	250	5

① AC voltages are 50/60Hz

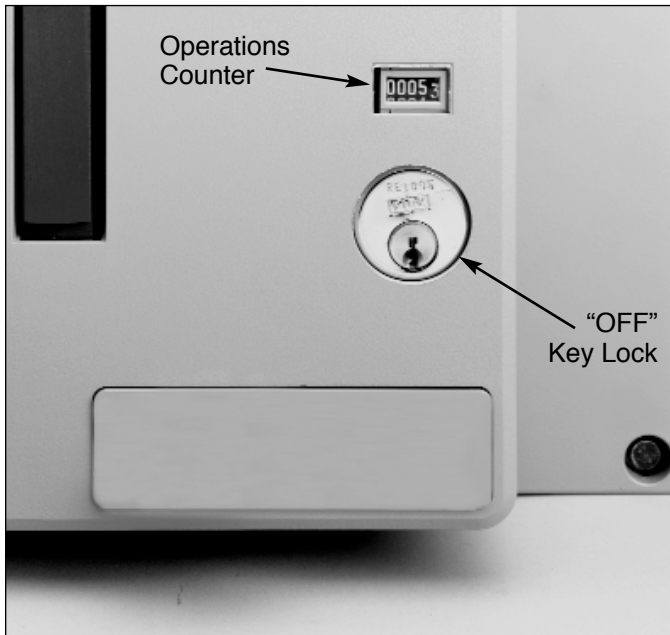

Figure 3-57 Cover Mounted Key Lock and Operations Counter



Figure 3-58 Cassette Mounted Key Lock

3-8.3 MECHANICAL ACCESSORIES

There are eight optional mechanical type accessories:

- Operations Counter
- Off Key Lock
- Cassette Lock
- Pushbutton Cover
- Prevent Close Cover
- Cassette Safety Shutters
- Cassette Cell Switch
- Door Escutcheon
- Waterproof Cover
- Mechanical Interlock

Operations Counter - The operations counter is a mechanical device used to provide a record of the number of circuit operations. It is mounted in the lower right portion of the circuit breaker and can be viewed through the front cover (Figure 3-57).

Off Key Lock - The off key lock secures the circuit breaker in the “OFF” position. It is mounted in the lower right portion of the circuit breaker and can be viewed through the front cover (Figure 3-57). The customer supplies the key lock. The provisions available are for Kirk, Castell or Ronis.

Cassette Lock - A cassette mounted lock can be used in conjunction with different interlocking schemes (such as main-tie-main) (Figure 3-58). The lock holds the circuit breaker trip-free in the connected position, preventing it from being closed.

Up to three lock cylinders can be installed on one cassette. Cutler-Hammer supplies the lock provisions only. The customer is responsible for the locks, which can be Kirk or Castell.

Pushbutton Cover - Padlockable covers are available to limit access to the “ON” and “OFF” pushbuttons (Figure 3-59). They can be installed with either or both pushbutton covers in place.

Prevent Close Cover - All access to the “ON” pushbutton can be prevented by adding the fixed Prevent Close Cover to the pushbutton cover.

Lockout Cover - When padlocked, it maintains the “OFF” button in the actuated position which prevents closure of the breaker.



Figure 3-59 ON-OFF Pushbutton Lockable Cover Plate

Cassette Safety Shutters - Automatically operated insulating type safety shutters are available for use with the drawout cassette. When the drawout circuit breaker is levered from the CONNECT position, the shutters automatically close to cover the fixed primary contacts (Figure 3-60). When the circuit breaker is levered into the cassette, the shutters automatically open permitting primary connections to be made (Figure 3-61).

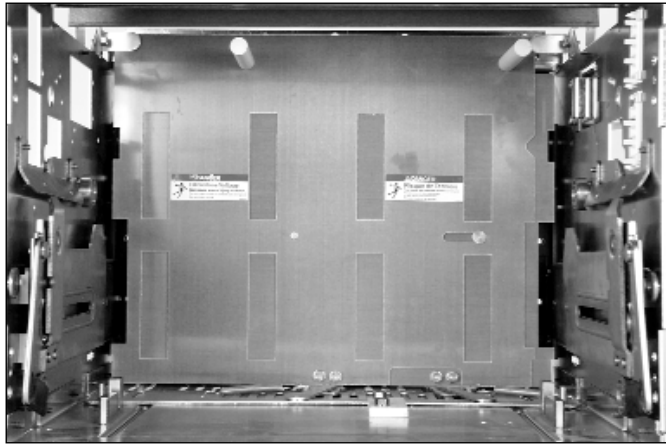

Figure 3-60 Typical Safety Shutters in Closed Position



Figure 3-61 Typical Safety Shutters in Open Position

Cassette Cell Switch - The cassette cell switch is a compartment position switch for drawout circuit breakers. It is available in a 2a2b or 4a4b contact configuration, and mounts on the right side of the cassette (Figure 3-62 and 3-63). Refer to the Ratings Table 3.6 for cell switch contact information. The cell switch changes status between the TEST and CONNECT positions.

Door Escutcheon - The door escutcheon is a molded frame used to seal the space between the circuit breaker and the compartment door cutout. It is supplied with a mounting gasket (Figure 3-64).



Figure 3-62 Cell Switch (Drawout Position Indicator) Unmounted

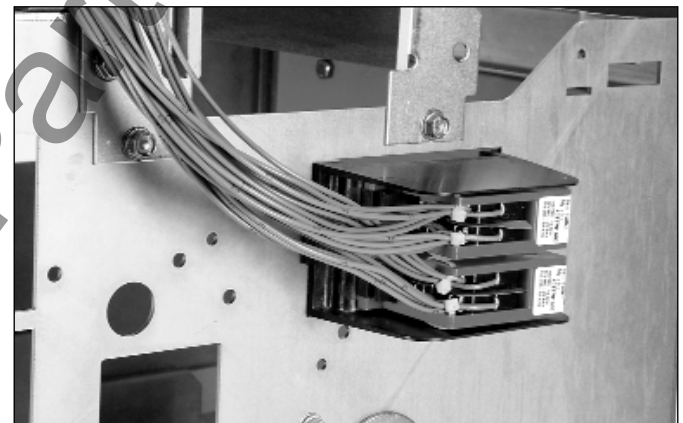

Figure 3-63 Cell Switches Mounted on Cassette

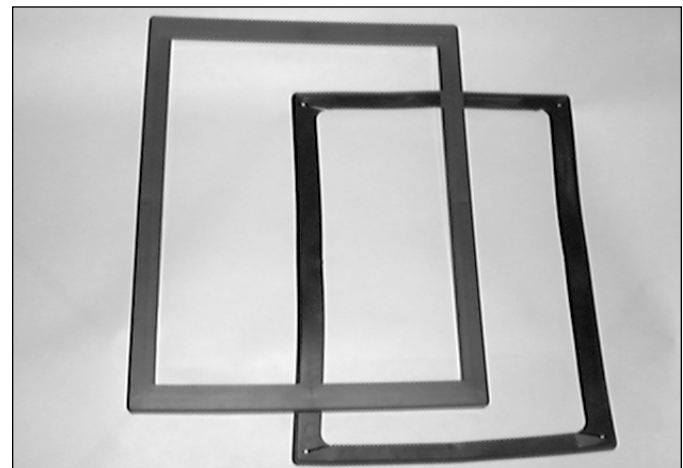

Figure 3-64 Door Escutcheon and Gasket



Figure 3-65 IP54 Waterproof Cover

IP54 Waterproof Cover - A hinged dome shaped waterproof cover attaches to the metal compartment door to provide waterproof protection for the circuit breaker (Figure 3-65).

Mechanical Interlock - A family of mechanical interlocks are available to interlock the closing of two or three Magnum circuit breakers. The mechanical interlock holds one or more circuit breakers tripped (prevents closure) when others are closed. A lever assembly is mounted on each breaker which interfaces with the pole shaft and the tripper bar. The lever assemblies are interconnected with either cables or rods, depending upon the relative orientation of the breakers. Rods can be used only when the circuit breakers to be interlocked are vertically stacked. Cables can be used for any orientation of the breakers. Mechanical interlocks are available for both fixed and drawout circuit breakers and in both 2-way and 3-way versions. An illustration of a 2-way cable interlock mounted on two drawout circuit breakers is shown in Figure 3-66.

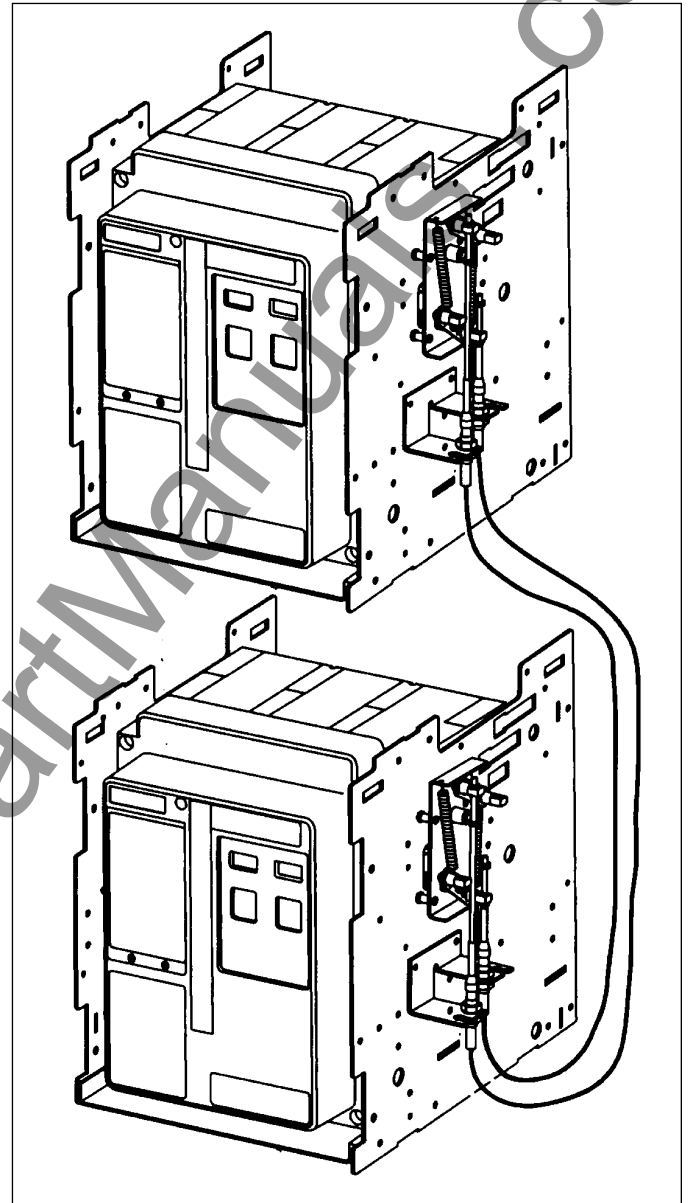

Figure 3-66 Cassette-Mounted 2-Way Cable Interlock

3-9 MDSL LIMITERS/BLOWN LIMITER INDICATION

An overall description of Magnum DSL circuit breakers was provided in sections 3-1 and 3-1.1. More detailed information is provided here relative to application, current limiters and blown limiter indication.

If current limiters are sized in keeping with Table 3.8 recommendations, the circuit breaker will function and interrupt routine fault currents. Infrequent high faults are cleared by the limiters. The limiters protect the circuit breaker on faults above the rating of the breaker. The limiters will blow below the circuit breaker short-time rating, if the fault currents equal the system maximum capacity.

In some applications the current limiters are sized smaller than necessary for protection of the MDSL circuit breaker in order to provide protection from downstream equipment. When this is done, the current limiter will blow on fault currents which could have been satisfactorily interrupted by the basic circuit breaker.

3-9.1 MDSL CURRENT LIMITERS

Do not replace limiters with sizes other than permitted by Table 3.8. MDSL current limiters have been tested and approved by Underwriters Laboratories, Inc. for use in MDSL circuit breakers when applied according to Table 3.8. They are not electrically or physically interchangeable with current limiting fuses of any other design.

The current limiters are held in place in an extension provided on the back of the circuit breaker (Figure 3-67). This extension makes the circuit breaker six inches deeper than the corresponding Magnum DS circuit breaker. The current limiters can only be removed from the circuit breaker and replaced when the MDSL circuit breaker is removed from its associated compartment. For this reason there is no fixed mounted version of the MDSL circuit breaker.

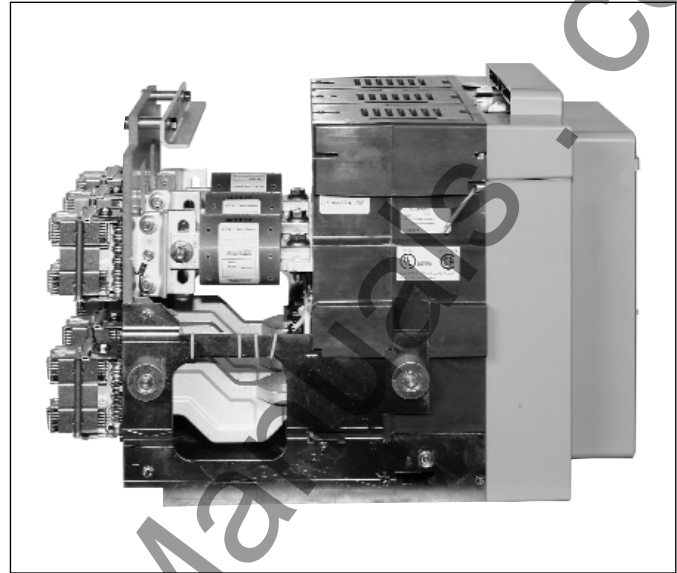

Figure 3-67 Magnum DSL Circuit Breaker (Side View)

3-9.2 BLOWN LIMITER SENSING

The blown limiter indicator provides a visual indication on the front of the MDSL circuit breaker when a current limiter in any phase has interrupted a short circuit. It is the visual element of the circuit that insures that the circuit breaker will be tripped when any current limiter has blown. This prevents single phase power from being applied to a three-phase load.

The indicator itself is a red pop out button located on the lower left portion of the breaker's front cover (Figure 3-68). A transformer is connected in parallel with the limiter. When a limiter is blown, the resulting voltage across the open limiter energizes the transformer. The transformer feeds a PC board to provide an output to the direct trip actuator to trip the circuit breaker, and an output to the indicator causing the button to pop out.



Figure 3-68 Blown Fuse Indicator

Table 3.8 MDSL Integral Current Limiter Selection (for Optimal Performance and Highest Fault Levels)

Magnum DSL Breaker Continuous Current Frame Rating (Amperes) ①				Sensor & Rating Plug (I_n)	Available MDSL Current Limiters ②									
800	1200	1600	2000		Minimum Size ③	Recommended Size ④	Maximum Size ⑤	Other Available Sizes (in addition to minimum, recommended and maximum sizes)						
MDSL08	MDSL12	MDSL16		200	MA250	MA600	MD3000	MA300	MA400	MA800	MB1200	MB1600	MB2000	MD2500
MDSL08	MDSL12	MDSL16		250	MA400	MA800	MD3000	MA600	MB1200	MB1600	MB2000	MD2500		
MDSL08	MDSL12	MDSL16		300	MA400	MA800	MD3000	MA600	MB1200	MB1600	MB2000	MD2500		
MDSL08	MDSL12	MDSL16		400	MA600	MB1200	MD3000	MA800	MB1600	MB2000	MD2500			
MDSL08	MDSL12	MDSL16		600	MA800	MB2000	MD3000	MB1200	MB1600	MD2500				
MDSL08	MDSL12	MDSL16		800	MB1200	MD2500	MD3000	MB1600	MB2000					
	MDSL12	MDSL16		1000	MB1600	MD2500	MD3000	MB2000						
	MDSL12	MDSL16		1200	MB2000	MD2500	MD3000							
		MDSL16	MDSL20	1600	MD3000	MD3000	MD3000							
			MDSL20	2000	MD3000	MD3000	MD3000							
			⑥	⑥	⑥	⑥	⑥							

- ① Select the Magnum breaker frame, then the current sensor and rating plug, and finally the current limiter. Current limiters are mounted integral to the circuit breaker. Refer non-automatic MDSL breaker application requests to Eaton/Cutler-Hammer
- ② Refer to MDSL current limiter curves for let-through and time characteristics.
- ③ The minimum selection provides for the lowest current let-through, but trip unit settings must be considered to avoid nuisance operation.
- ④ The recommended selection avoids nuisance limiter operation and allows for system coordination within the trip unit settings while minimizing let-through.
- ⑤ The maximum selection provides for maximum system coordination with let-through characteristics per the limiter selected.
- ⑥ Heat sinks applied in conjunction with current limiters on this breaker rating.

SECTION 4: DRAWOUT CIRCUIT BREAKER AND CASSETTE

4-1 GENERAL

Section 3 discussed topics and features common to all Magnum circuit breakers, no matter what the mounting configuration or type (drawout or fixed, MDS, MDSX or MDSL). In this section, features unique to the drawout type circuit breaker and drawout cassette, not covered elsewhere, are discussed. Section 5 covers features unique to MDS and MDSX fixed type circuit breakers only. Drawings and dimensions associated with all circuit breakers, drawout cassettes and any appropriate primary bus connections can be found in a separate document entitled **Engineering Data TD01301004E**. The installation and levering of a drawout circuit breaker were discussed in Section 2. If necessary, review that information, since it will not be repeated here.

4-1.1 DRAWOUT CASSETTE

A drawout circuit breaker is used in combination with a fixed drawout cassette (Figures 4-1 and 4-3); the drawout circuit breaker is equipped with automatic primary disconnects (Figure 4-2). The cassette provides all of the necessary interfaces to the drawout circuit breaker including automatic primary and secondary connections. For the MDS narrow frame circuit breaker a single cassette style using horizontal stabs and horizontal cus-tomer bus bar terminals is available (Figure 4-4). For the MDS and MDSX standard and double-wide circuit breakers three cassette styles, all with vertical stabs, are available: basic, standard, and universal. The standard cassette supplies vertical stab/terminals only (Figure 4-5). The basic cassette omits the copper stab/terminals so that these pieces can be integrated with vertical bus bars provided by the switchgear builder (Figure 4-6). The universal cassette provides a set of flat pad terminals on the rear of the cassette that can be adapted to vertical, horizontal or front connection (Figures 4-7). The MDSL circuit breaker with integral current limiters is six inches deeper than the MDS or MDSX circuit breaker and utilizes a cassette similar to the MDS and MDSX standard type cassette except six inches deeper (Figure 4-8 and 4-9). Mounting locations for cell (TOC) switches, safety shutters, mechanical interlocks and key interlocks are provided on the cassette.



Figure 4-1 MDS/MDSX Drawout Circuit Breaker in Cassette

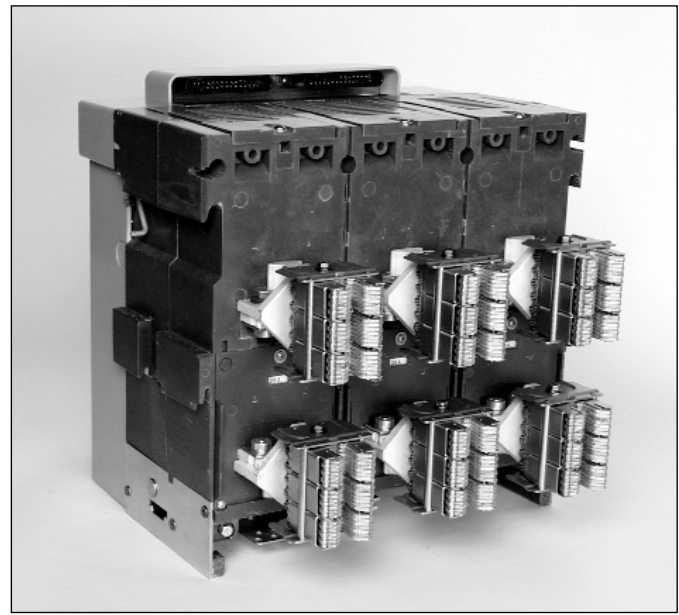
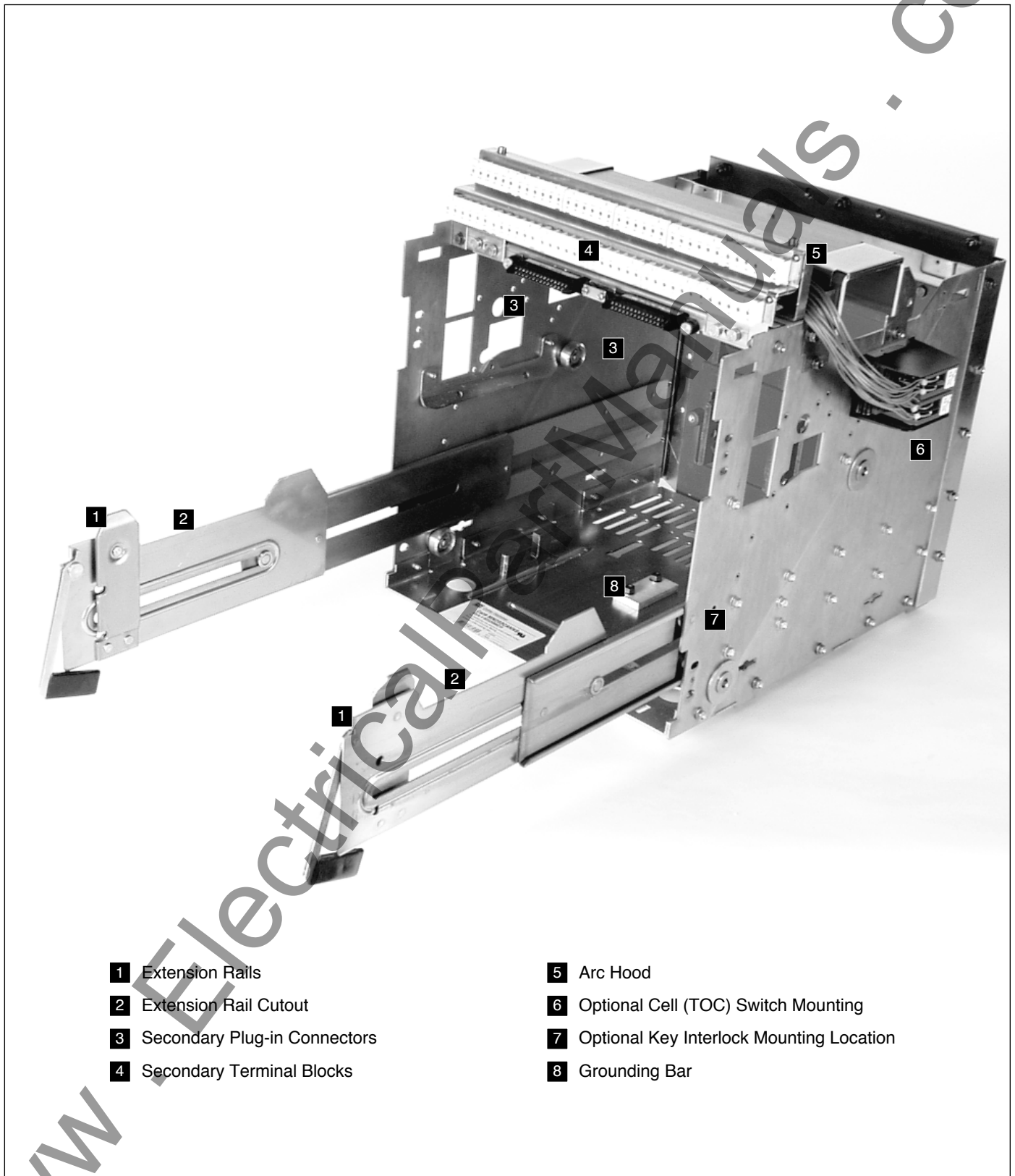

Figure 4-2 MDS/MDSX Drawout Circuit Breaker with Automatic Primary Disconnects



- | | |
|---------------------------------------|---|
| 1 Extension Rails | 5 Arc Hood |
| 2 Extension Rail Cutout | 6 Optional Cell (TOC) Switch Mounting |
| 3 Secondary Plug-in Connectors | 7 Optional Key Interlock Mounting Location |
| 4 Secondary Terminal Blocks | 8 Grounding Bar |

Figure 4-3 Typical Drawout Cassette Features

4-2 DRAWOUT CIRCUIT BREAKER DIMENSIONS

The Magnum drawout circuit breaker connects to the fixed primary stabs of the drawout cassette through the primary finger clusters attached to the rear of the circuit breaker. Three different frame sizes cover all Magnum circuit breakers from an overall dimensional standpoint. Circuit breaker drawings can be found in *Engineering Data TD01301004E*.

4-3 DRAWOUT CASSETTE DIMENSIONS

Cassette drawings provide all the dimensional information required for all mounting configurations and can also be found in *Engineering Data TD01301004E*. Review carefully for a specific installation.

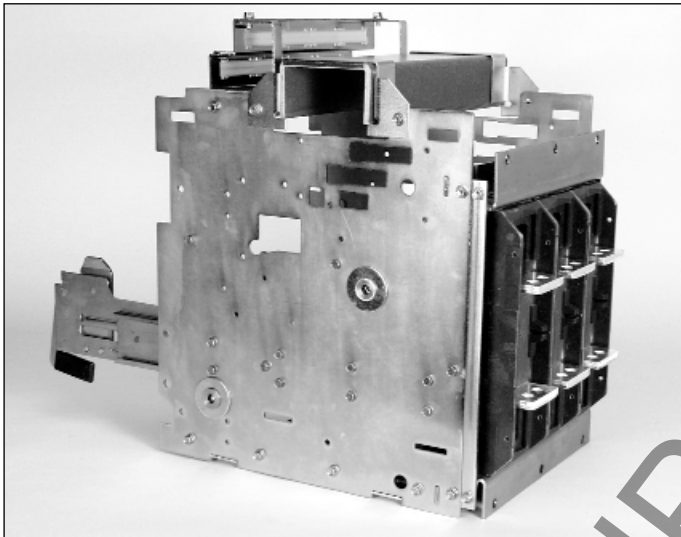

Figure 4-4 Typical MDS Narrow Frame Cassette (Horizontal Terminals)

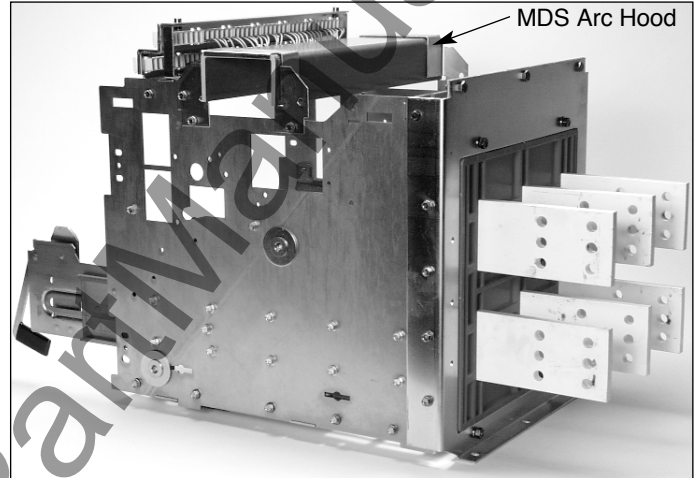

Figure 4-5 Typical MDS /MDSX Standard Cassette (Vertical Terminals) (Shown with MDS Type Arc Hood)

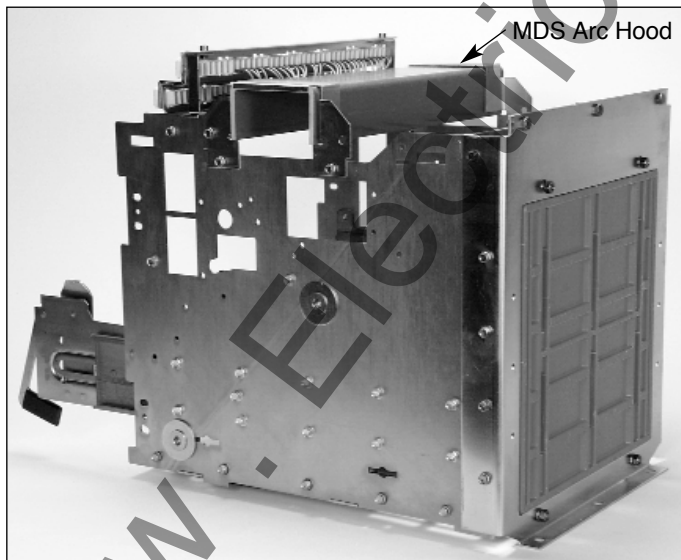

Figure 4-6 Typical MDS/MDSX Basic Cassette (Without Stabs) (Shown with MDS Type Arc Hood)

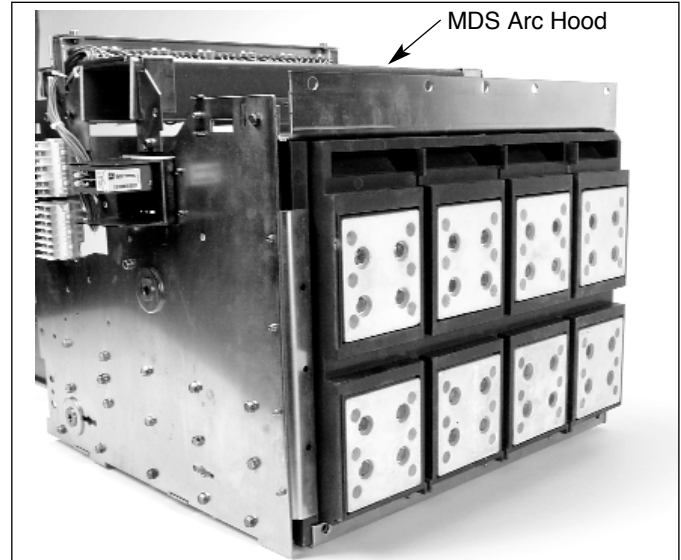

Figure 4-7 Typical MDS/MDSX Universal Cassette, 4-Pole (Flat Terminal Pads) (Shown with MDS Type Arc Hood)

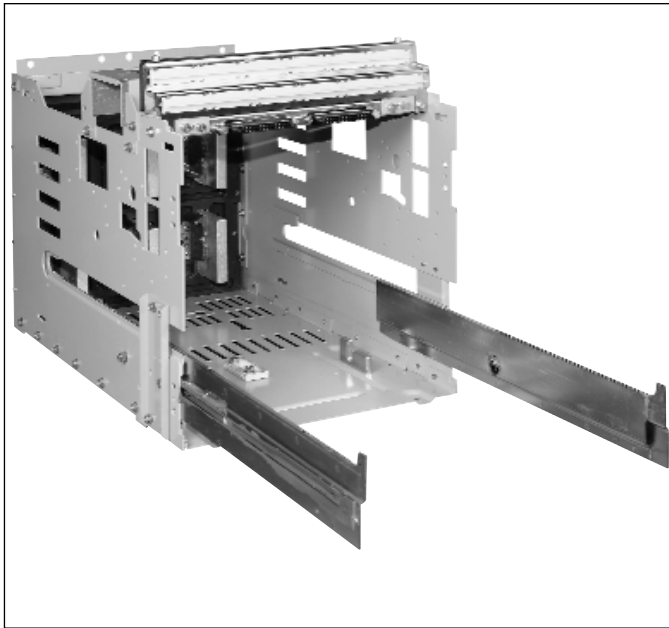

Figure 4-8 Typical MDSL Standard Cassette (Front View)

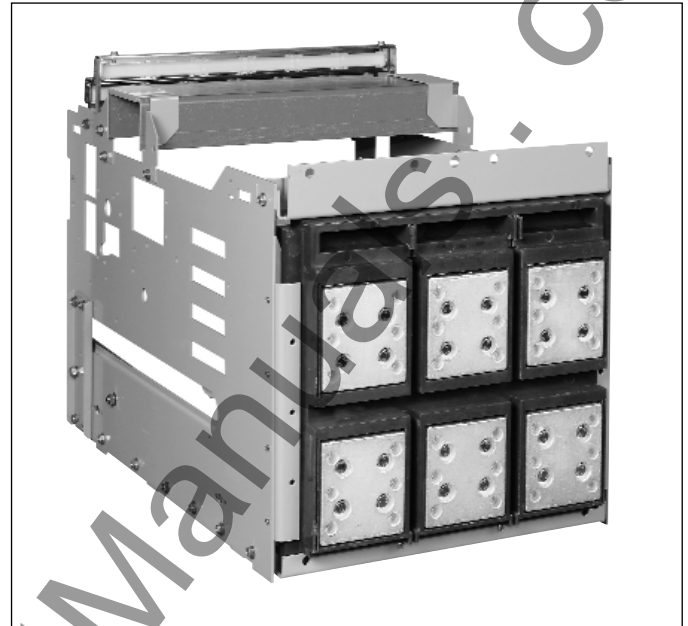

Figure 4-9 Typical MDSL Standard Cassette (Rear View)

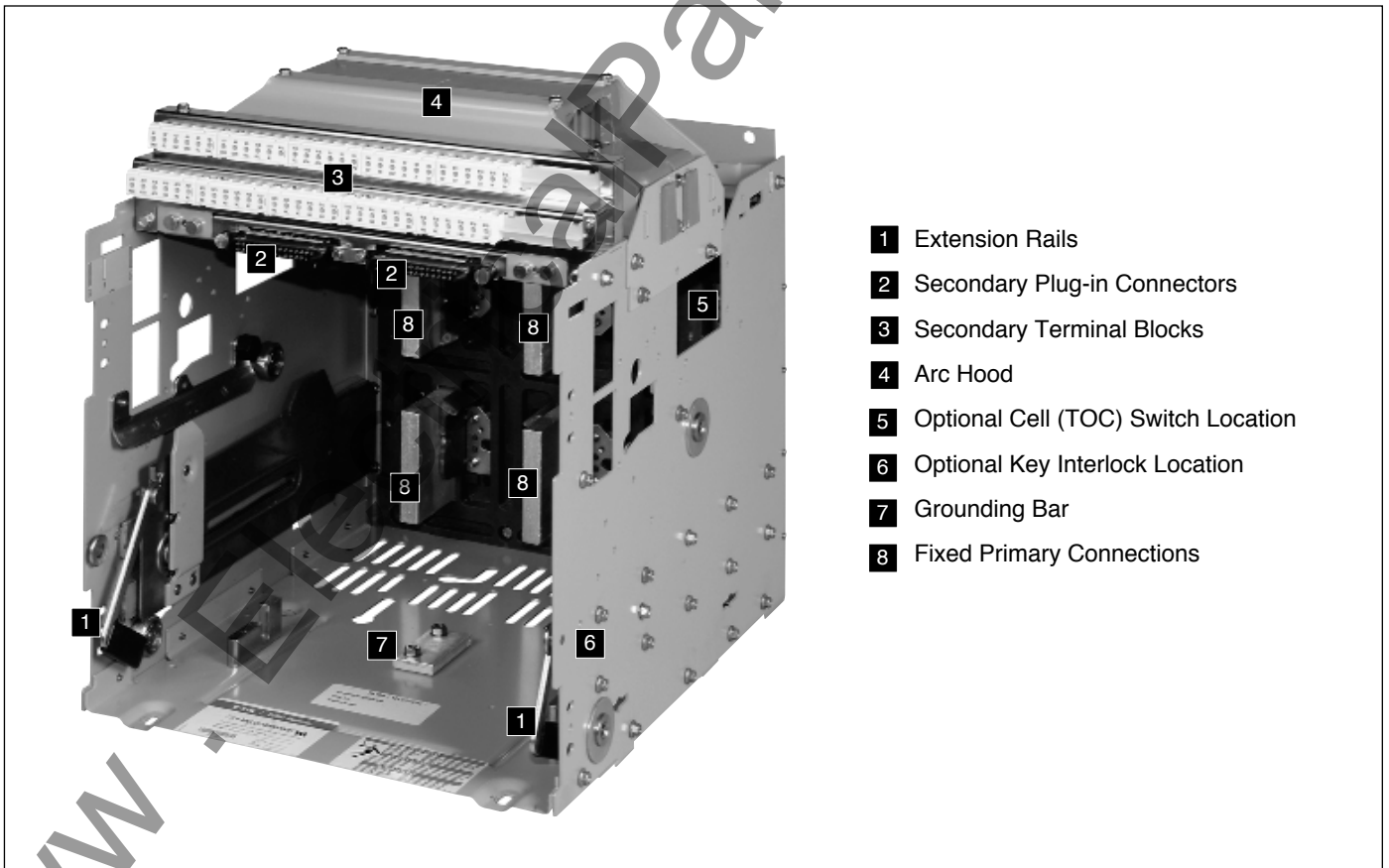

Figure 4-10 Typical MDSX Type Drawout Cassette

- 1** Extension Rails
- 2** Secondary Plug-in Connectors
- 3** Secondary Terminal Blocks
- 4** Arc Hood
- 5** Optional Cell (TOC) Switch Location
- 6** Optional Key Interlock Location
- 7** Grounding Bar
- 8** Fixed Primary Connections

SECTION 5: FIXED CIRCUIT BREAKER

5-1 GENERAL

Section 3 discussed topics and features common to all Magnum circuit breakers, no matter what the mounting configuration or type. In this section, features unique to the fixed configuration (MDS/MDSX only) not covered elsewhere are covered. Drawings and dimensions associated with all fixed circuit breakers and any appropriate primary bus connections can be found in a separate document entitled *Engineering Data TD01301004E*. The installation of a fixed circuit breaker was discussed in Section 2. If necessary, review that information, since it will not be repeated here.



WARNING

FAILURE TO COMPLY WITH INSTALLATION OF THE FIXED MOUNTED MDSX ARC HOOD ASSEMBLY COULD RESULT IN EQUIPMENT DAMAGE, BODILY INJURY OR EVEN DEATH.

The MDSX fixed mounted breaker is shipped with a factory installed arc hood assembly. This assembly is **required to be installed** on the top of the breaker prior to the unit being placed in service.

5-2 FIXED CIRCUIT BREAKER DIMENSIONS

The standard fixed circuit breaker is supplied with horizontally mounted primary connections (Figure 5-1). Optional vertical primary adaptors are available for different bus configurations. Refer to *Engineering Data TD01301004E* for fixed circuit breaker dimensions, vertical adaptor dimensions and vertical adaptor assembly details.



Figure 5-1 Fixed MDS/MDSX Circuit Breaker with Available Vertical Adaptor

SECTION 6: INSPECTION AND MAINTENANCE

6-1 GENERAL



WARNING

FAILURE TO INSPECT, CLEAN AND MAINTAIN CIRCUIT BREAKERS CAN REDUCE EQUIPMENT LIFE OR CAUSE THE EQUIPMENT NOT TO OPERATE PROPERLY UNDER FAULT CONDITIONS. THIS COULD RESULT IN EQUIPMENT DAMAGE, BODILY INJURY OR EVEN DEATH.



CAUTION

INSPECTION AND MAINTENANCE PROCEDURES SHOULD BE CARRIED OUT ONLY BY PERSONNEL FAMILIAR WITH THE HAZARDS ASSOCIATED WITH WORKING ON POWER CIRCUIT BREAKERS. ADDITIONALLY, THEY SHOULD BECOME FAMILIAR WITH THE SPECIFICS ASSOCIATED WITH TYPE MAGNUM DS CIRCUIT BREAKERS AS PRESENTED IN THIS INSTRUCTION BOOK.

Magnum Circuit Breakers are “Top of the Line” equipment. This means they are manufactured under a high degree of quality control, with the best available materials and with a high degree of tooling for accuracy and parts interchangeability. Design tests and actual installation experience show them to have durability well beyond minimum standards requirements. However, because of the variability of application conditions and the great dependence placed upon these circuit breakers for protection and the assurance of service continuity, inspection and maintenance activities should take place on a regularly scheduled basis.

Since maintenance of these circuit breakers consists mainly of keeping them clean, the frequency of scheduled inspection and maintenance depends to some degree on the cleanliness of the surroundings. Cleaning and preventive measures are a part of any good maintenance program. Plant operating and local conditions can vary to such an extent that the actual schedule should be tailored to the conditions. When the equipment is subject to a clean and dry environment, cleaning is not required as frequently as when the environment is humid with a significant amount of dust and other foreign matter.

It is recommended that maintenance record sheets be completed for the equipment. Careful and accurate documentation of all maintenance activities provides a valuable historical reference on equipment condition over time.

6-2 GENERAL CLEANING RECOMMENDATIONS

Circuit breaker cleaning activities should be a part of an overall activity that includes the assembly in which the circuit breaker is installed. Loose dust and dirt can be removed from external surfaces using an industrial quality vacuum cleaner and/or lint free cloth. Unless otherwise indicated, never use high pressure blowing air, since dirt or foreign objects can be driven into areas, such as the breaker mechanism, where additional friction sources could create problems. Never use a wire brush to clean any part of the circuit breaker.

6-3 WHEN TO INSPECT

Do not wait for specific scheduled periods to visually inspect the equipment, if there are earlier opportunities. If possible, make a visual inspection each time a circuit breaker compartment door is opened, and especially when a circuit breaker is withdrawn on its compartment extension rails. This preventive measure could help to avoid future problems.

Industry standards for this type of equipment recommend a general inspection and lubrication after the number of operations listed in Table 6.1 of this section. This should also be conducted at the end of the first six months of service, if the number of operations has not been reached.

Table 6.1 Inspection Frequency

Breaker Frame Size	Interval ^① (Breaker Cycles)
800 amperes and below	1750
Between 800 and 3000 amperes	500
3000 amperes and above	250

① Breaker Cycle = one no load open/close operation

After the first inspection, inspect at least once a year. If these recommended inspections show no maintenance requirements, the period may be extended to a more economical point. Conversely, if the recommended inspection shows, for instance, a heavy accumulation of dirt or other foreign matter that might cause mechanical, insulation or other electrical damage, the inspection and maintenance interval should be decreased.

6-4 WHAT TO INSPECT

What to inspect and to what extent is dictated by the nature of the maintenance function. Routine inspections require one type of observation. Inspections following a known high level fault require more detailed inspections.

A drawout type circuit breaker should first be withdrawn from its compartment onto the compartment's extension rails. When the inspection is complete, the circuit breaker can be levered to the TEST position to check the electrical operations of the circuit breaker. During the levering out and levering in of the circuit breaker, be aware for any signs that would indicate that this process is not working properly.

During the inspection of fixed type circuit breakers, bus systems supplying the fixed circuit breakers **should be de-energized** for convenience and safety.

For functional testing of the trip unit, refer to the separate detailed instruction book dedicated to the trip unit.

Once the circuit breaker has been cleaned as described in paragraph 6-2, visually inspect it for any signs of damage, missing or loose parts and unusual wear. Be especially alert for foreign matter that must be removed. On drawout circuit breakers, inspect the primary disconnect finger clusters for signs of wear and erosion. Make appropriate corrections to anything found out of order.

6-4.1 FUNCTIONAL FIELD TESTING

NOTICE

Before doing any work on drawout type circuit breakers, make sure the breaker is levered out to the TEST or DISCONNECT position. During the levering out and levering in of the circuit breaker, be aware of any signs that would indicate that the levering process is not working properly. If working on a fixed circuit breaker, bus systems should be de-energized for convenience and safety. The circuit breaker should be switched to the OFF position and the mechanism springs discharged.

Eaton Cutler-Hammer recommends that the following functional tests be performed on Magnum circuit breakers as part of any maintenance procedure. The circuit breaker should be removed from service and Cutler-Hammer notified if the circuit breaker fails to perform any of these tests successfully. Please be prepared to provide the number of operations the circuit breaker has to date as well as the following nameplate information:

- ❶ G.O.#: It: Seq: ❷ Code:
- ❸ Cust. P.O.:
- ❹ Date of Manufacture
- ❺ Cat#:

Magnum DS

MDSC32
Low Voltage AC Power Circuit Breaker
3200 Amp Frame 3 Pole 50/60 Hz

Interruption Ratings in Amps		
Max Volts	Inst Trip	Short Delay
635	100,000A	85,000A
508	100,000A	85,000A
254	100,000A	85,000A

Accessories		
Motor Operator	110 - 125 VAC	50/60 Hz
Trip Unit Power	120 VAC	50/60 Hz
Aux Switches	6A / 6B	

G.O.#: SAMPLE It: 001 Seq: 002
 Cust P.O.: SAMPLE
 Code:
 11/21/01 10:49:37
 CAT#: MDSC323WEA 32MUA AAN6N NNNAX
 Enclosure Requirements Dwg: 2C13090
 Installation and Operating Instructions: I.B. 2C12060
 Made in USA

Manual Operation Functional Test

Charge the breaker mechanism springs either using the charging handle or the motor operator. Press the ON pushbutton to close the breaker manually and verify closing by noting the state of the indicating flag. Charge the breaker mechanism springs either using the charging handle or the motor operator. If using the motor operator, disconnect power to it to prevent automatic recharging. Press the OFF pushbutton to manually open the breaker. Press the ON pushbutton to manually close the breaker. Is the breaker closed? Press the OFF pushbutton to manually open the breaker. Is the breaker open? Repeat this entire described test procedure three times.

Electrical Operation Functional Test

This test procedure is based on the assumption that the breaker is equipped with optional shunt trip and spring release accessories. If one accessory is missing, substitute the manual button to replace the accessory's function.

Charge the breaker mechanism springs either using the charging handle or the motor operator. Close the breaker by applying rated voltage to the spring release accessory and verify closing by noting the state of the indicating flag. Charge the breaker mechanism springs either using the charging handle or the motor operator. If using the motor operator, disconnect power to it to prevent automatic recharging. Open the breaker by applying rated voltage to the shunt trip accessory. Close the breaker using the spring release accessory. Is the breaker closed? Open the breaker using the shunt trip accessory. Is the breaker open? Repeat this entire described test procedure three times.

Trip Unit Overload Functional Test

This test uses the Digitrip 1150 self test function, the Digitrip Test Kit or the handheld Magnum Functional Test Kit. Review test kit instructions for the trip unit. Instruction leaflet 5720B55, section 1.2 or 1.3 applies for instantaneous test procedures or paragraph 5.2.1 “1150 Self Testing, Trip Mode” in the trip unit instruction leaflet 70C1036.

Charge the breaker mechanism springs either using the charging handle or the motor operator. Press the ON pushbutton to close the breaker manually and verify closing by noting the state of the indicating flag. Charge the breaker mechanism springs either using the charging handle or the motor operator. If using the motor operator, disconnect power to it to prevent automatic recharging. Trip the breaker with a trip unit test. Verify that the trip indicator pop out button (if so equipped) is “out” and then reset it. Press the ON pushbutton to manually close the breaker. Is the breaker closed? Trip the breaker with a trip unit test. Verify that the trip indicator pop out button (if so equipped) is “out” and then reset it. Repeat this entire described test procedure three times. Reset the blinking red cause of trip LED on the trip unit by pressing the Reset/Battery Test pushbutton.

6-4.2 ARC CHUTE INSPECTION

When a circuit breaker experiences a high level fault or during regularly scheduled maintenance periods, the circuit breaker’s arc chutes and arc chambers should be inspected for any kind of damage or dirt. Be especially alert for signs of significant erosion of the V-shaped plates inside the arc chute.

Arc chutes fit inside the arc chambers and down over a the primary contacts. Each arc chute is held in place by either 1 (MDS) or 4 (MDSX) top inserted screws (Figure 6-1 shows MDS). Begin by removing the arc chute screws and all three arc chutes. Turn each arc chute upside down to visually inspect the inside (Figure 6-2).

Since the arc chutes are removed, this is an ideal time to inspect primary contacts for wear using the circuit breaker’s contact wear indicators. The details associated with primary contact inspection are presented in the next paragraph.

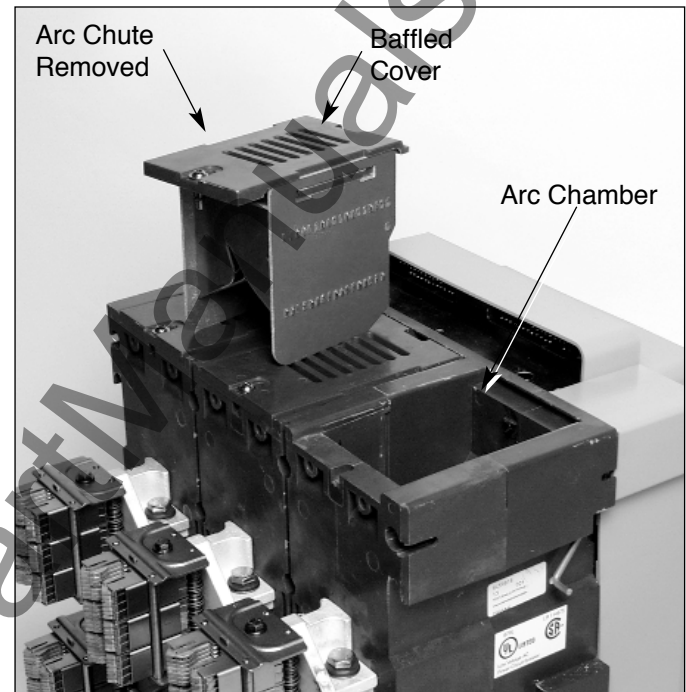

Figure 6-1 Top Rear View of Circuit Breaker with One Arc Chute Removed



Figure 6-2 Bottom View of Arc Chute



Figure 6-3 Primary Contacts with Circuit Breaker Open (Not Used for Contact Wear Inspection)

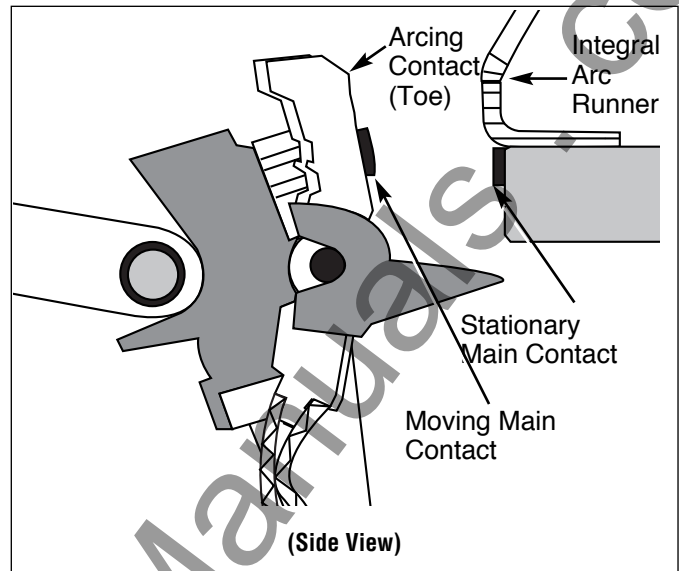

Figure 6-4 Contact Inspection Area with Circuit Breaker Open



WARNING

ARC CHUTES MUST ALWAYS BE SECURED PROPERLY IN PLACE BEFORE A CIRCUIT BREAKER IS INSTALLED IN A CIRCUIT BREAKER COMPARTMENT. FAILURE TO DO THIS COULD RESULT IN EQUIPMENT DAMAGE, BODILY INJURY OR EVEN DEATH.

When the inspections are complete, position each arc chute down over its respective set of primary contacts, and secure in place with the screw removed earlier. Torque the arc chute screws to 35 to 45 in-lb.

6-4.3 PRIMARY CONTACT INSPECTION

With the arc chutes removed, visually inspect each primary contact structure for signs of wear and/or damage. The primary contacts with the circuit breaker open can be viewed by looking directly down into the arc chamber (Figure 6-3 and 6-4).

A contact wear indicator is provided for each primary contact and indicates whether or not the contact should be replaced. Inspection of the contacts using the contact wear indicators is conducted **only with the circuit breaker closed** (Figures 6-5).

NOTICE

When making a contact wear inspection, always make the inspection by looking straight down into the arc chamber for the proper perspective. Viewing the contact wear area from an angle could distort the view.

The contact wear indicator is the relative position of the individual contact fingers to a narrow, side-to-side ledge inside the arc chamber. The ledge is actually part of the arc chamber. When the circuit breaker is closed and the contacts are in good condition, the narrow ledge is covered by the back end of the contacts (Figure 6-5). If the back end of the contacts do not totally cover the ledge, the contacts should be replaced.



WARNING

ARC CHUTES MUST ALWAYS BE SECURED PROPERLY IN PLACE BEFORE A CIRCUIT BREAKER IS INSTALLED IN A CIRCUIT BREAKER COMPARTMENT. FAILURE TO DO THIS COULD RESULT IN EQUIPMENT DAMAGE, BODILY INJURY OR EVEN DEATH.

Once the inspection is complete, be sure the arc chutes are properly replaced as previously described in paragraph 6-4.1.

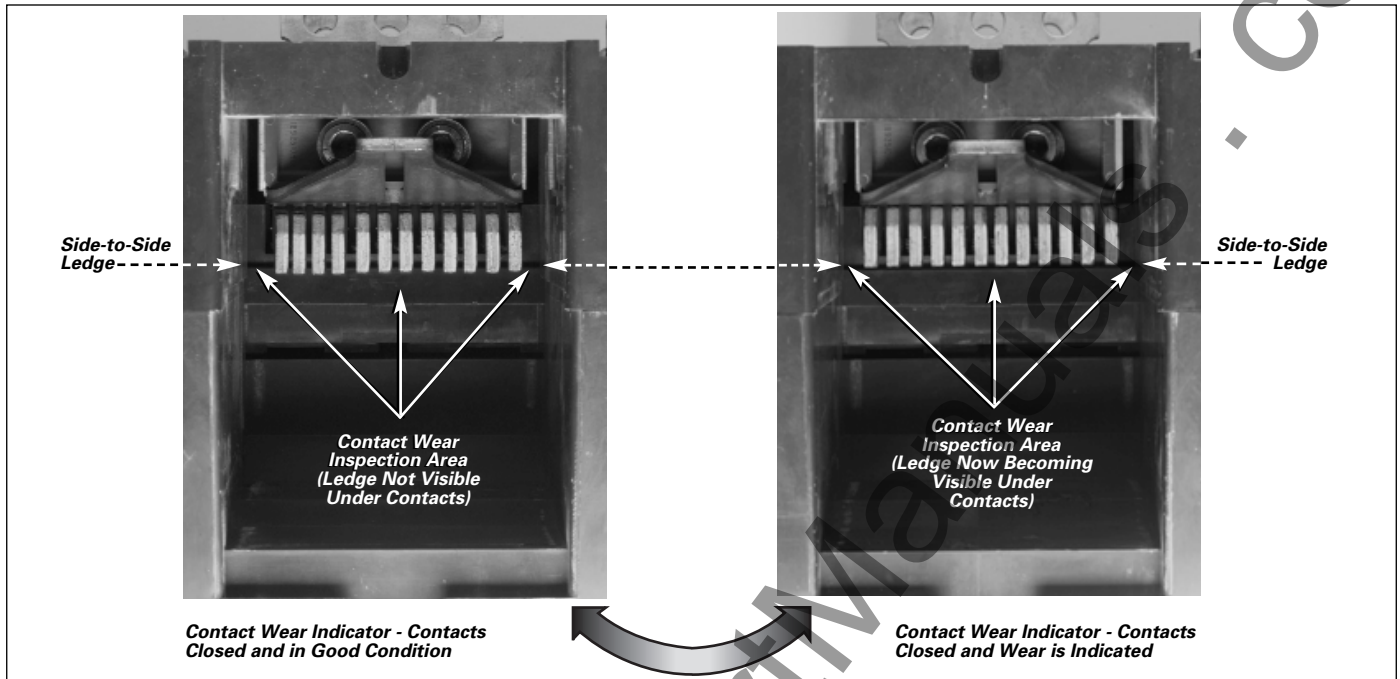

Figure 6-5 Use of Contact Wear Indicator with Circuit Breaker Closed

6-5 CIRCUIT BREAKER MODIFICATIONS AND CHANGES

The topics discussed here will relate to those actions that can be taken in the field to change, update, maintain or repair a Magnum circuit breaker. This information does not, however, include most accessory devices. Their installation is covered by separate instruction leaflets dedicated to the individual devices. The tasks described here do not, under ordinary circumstances, require any assistance beyond the appropriate instructional material. If further assistance is required, however, contact your Cutler-Hammer representative.

6-5.1 RATING PLUG REPLACEMENT

NOTICE

If a rating plug is not installed in the trip unit, the trip unit will trip when energized. Also remember that the trip unit's rating plug and the circuit breaker's current sensors must have matching ratings.

To remove the rating plug from the trip unit, open the small rating plug door located on the right side of the trip unit (Figure 6-6). The trip unit's battery cavity is also located behind this door. Use a 1/8" wide screwdriver to remove the M4 screw holding the rating plug in position. Pull the door to release the rating plug from the trip unit.



Figure 6-6 Trip Unit Rating Plug Location

To install a new rating plug, insert the rating plug into the cavity where the other rating plug was removed. Make sure the three pins on the rating plug are aligned with the sockets in the cavity. The rating plug should fit with a slight insertion force.



CAUTION

TO PREVENT DAMAGE TO THE RATING PLUG, DO NOT FORCE IT INTO THE MOUNTING CAVITY.

Use the same 1/8" screwdriver to tighten the M4 screw and secure the rating plug in the trip unit. The maximum torque on the mounting screw is 15 in-oz. Close the rating plug door.

6-5.2 CURRENT SENSOR REPLACEMENT

NOTICE

Remember that the trip unit's rating plug and the circuit breaker's current sensors must have matching ratings.

The three current sensors are installed at the rear of the circuit breaker on the lower terminals. A cover with sensor rating viewing windows covers the sensors and is held in place with screws (Figure 6-7). Remove the cover by removing the screws.



Figure 6-7 Current Sensor Cover in Place Over Sensors

If the circuit breaker is a drawout configuration, the lower primary disconnect finger clusters and the vertical adaptors must first be removed from frame sizes up to 3000/3200A. On the 3000/3200A frame, both the upper and lower primary disconnects and vertical adaptors must be removed. Each primary disconnect finger cluster is removed by loosening the two hex-head bolts with a 10 mm wrench. These bolts do not have to be completely removed to slide the primary disconnects off of the terminals. Remove the vertical adaptors next from the circuit breaker terminals by removing the two or three 10 mm bolts holding them in place (Figure 6-8).

The current sensors are removed by pulling them off of the terminals and unplugging the wiring plugs from the sensors (Figure 6-8).

Install new current sensors by connecting the wiring plugs to the sensors and sliding the sensors over the terminals. Reinstall the cover over the sensors and secure in place with the screws previously removed.

Reinstall the previously removed vertical adaptors to the terminals using the removed hardware and **40 ft-lb** of tightening torque. Make sure the vertical adaptors are square to the rear housing. Slip the primary disconnects on to the vertical adaptors. Make sure the primary disconnects are fully inserted on to the vertical adaptors. Tighten the two retention bolts to **40 in-oz** of torque. Properly engaged and secured retention bolts should engage the slots or holes in the vertical adaptors.

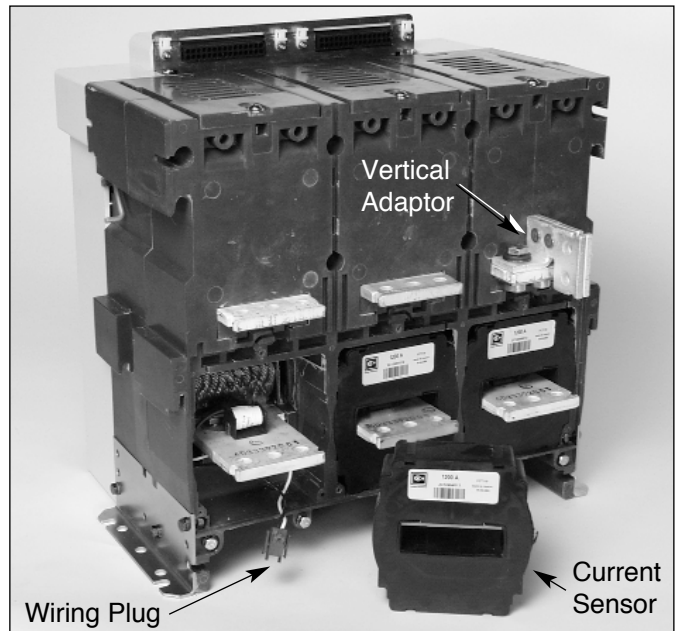

Figure 6-8 One Current Sensor Shown Removed and Disconnected

6-5.3 CURRENT LIMITER REPLACEMENT (MDSL)

NOTICE

Do not replace limiters with sizes other than permitted by Table 3.8. MDSL current limiters have been tested and approved by Underwriters Laboratories, Inc. for use in MDSL circuit breakers when applied according to Table 3.8. They are not electrically or physically interchangeable with current limiting fuses or any other design.

The current limiters are held in place in an extension provided on the back of the circuit breaker (Figure 6-9). They can only be removed from the circuit breaker and replaced when the MDSL circuit breaker is removed from its associated compartment.

6-5.3.1 REPLACING TYPE MA AND MB CURRENT LIMITERS

The Type MA and MB current limiters have a single hole in each end blade for attaching the limiters to the breakers. Removal of the limiters is easily accomplished by simply removing the hardware.

Replacement of limiters should be performed as follows:

Note: Replace the center phase limiter first.

Step 1: Place the Belleville washer on the hex head bolt such that the dome of the washer is towards the head of the bolt.

Step 2: Place a flat washer on next.

Step 3: Place each of these hardware assemblies through the holes in the limiter end blades, and put one end through the center hole of the breaker's fixed horizontal primary terminal. The other end attaches to the center hole on the rear stab.

Step 4: Place a lockwasher and a hex nut onto each bolt and tighten by hand.

Step 5: The first bolt to torque is the one attaching the limiter to the breaker's fixed, horizontal, primary terminal (torque to 40 ft-lbs).

Step 6: Torque the remaining bolt to 40 ft-lbs.

6-5.3.2 REPLACING TYPE MD CURRENT LIMITERS

Type MD current limiters have three holes in each of the end blades for attaching the limiters to the breakers. Removal of the limiters is easily accomplished by simply removing the hardware.

Replacement of limiters should be performed as follows:

Note: Replace the center phase limiter first.

Step 1: Place the Belleville washer on the hex head bolt such that the dome of the washer is towards the head of the bolt.

Step 2: Place a flat washer on next.

Step 3: Place three of these hardware assemblies through the holes in one of the limiter end blades, and put this end blade on the breaker's fixed horizontal primary terminal. These three bolts can be threaded into the nut plate that was originally installed and tighten by hand. The other end of the limiter will attach to the rear stab.

Step 4: Put the remaining three bolt assemblies through the holes in the other end blades and secure them with lockwashers and hex nuts. Hand tighten only.

Step 5: First torque the bolts attaching the limiter to the breaker's fixed, horizontal, primary terminal (torque to 40 ft-lbs).

Step 6: Torque the remaining bolts to 40 ft-lbs.

Step 7: Install the phase barriers between the limiters.

6-5.3.3 REPLACING TYPE MD CURRENT LIMITERS ON MDSL20 BREAKERS

Replacement of MD limiters on the MDSL20 circuit breaker is exactly the same as previously described in Paragraph 6-5.3.2, except that the heat sinks (Figure 6-9) must be installed with the bolt assemblies on each of the breaker's fixed, horizontal, primary terminals.

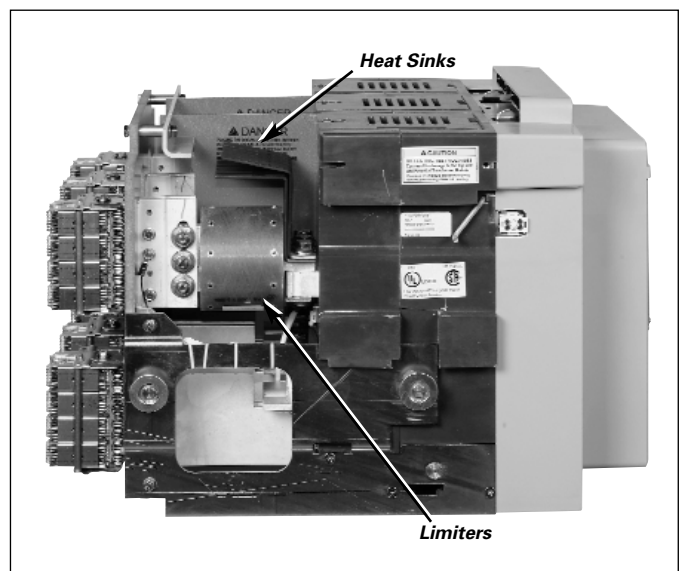

Figure 6-9 MD Limiters Shown Mounted in Extension

www.ElectricalPartManuals.com

SECTION 7: TROUBLESHOOTING

7-1 INTRODUCTION

Table 7.1 will help to determine the probable causes of simple circuit breaker problems and possible corrective actions. Possible problems associated with the electronic trip unit are covered in companion publications, I.L. 70C1037H04 and I.L. 70C1036H05. If the problem cannot be resolved with the aid of one or both of these guides, contact the Cutler-Hammer service center for more in-depth assistance.

Table 7.1 Circuit Breaker Troubleshooting Guide (continued on next page)

Symptom	Probable Cause	Corrective Actions
The circuit breaker <i>trips</i> open (red fault trip indicator button is <i>out</i> and/or fault indicator LED is <i>lighted</i>) when closed on a load current	Rating plug not installed and load current through the breaker	Install rating plug that corresponds to current sensors
	Repeated closing on transient (in-rush) current with thermal memory active	Wait for circuit breaker (and loads) to cool before re-closing
	An overload or fault current condition	Use status and fault indicators to help locate and remove overload or fault condition
Circuit breaker <i>opens</i> (fault trip indicator button is <i>not out</i>)	Undervoltage release operates; voltage too low or zero	Check and correct the UVR supply voltage (85-110% rated voltage)
	Shunt trip operates	Check control signal(s) to shunt trip; correct if necessary
	Trip latch is defective	Inspect latch condition and engagement before closing; consult Cutler-Hammer service center

Table 7.1 Circuit Breaker Troubleshooting Guide (continued from previous page)

Symptom	Probable Cause	Corrective Actions
Circuit breaker cannot be opened remotely, but can be opened locally	Shunt trip control signal absent or too low	Check supply voltage exceeds 70% of rated voltage when signal is applied to shunt trip
	Shunt trip is faulty or improperly installed	Remove front cover; check voltage supplied to shunt trip; make sure shunt trip is seated and retainer snapped into place. Check for shunt trip motion; replace shunt trip if faulty
	Secondary contact wiring problem	Make sure electrical pin and socket connectors are properly seated in molded plug. Verify proper wiring
Circuit breaker cannot be opened locally	OPEN pushbutton locked	Remove lock
	Faulty mechanism or main contacts welded	Contact Cutler-Hammer service center
Circuit breaker makes no attempt to close with either local (manual) or remote controls; springs do not discharge	Closing spring not fully charged (check SPRING CHARGED indicator)	Charge spring manually; check voltage to electrical operator; replace electrical operator if faulty
	If equipped with undervoltage release, undervoltage release is not energized or is faulty	Unplug undervoltage release from mounting deck and retry closing operation; if OK, check voltage supply to undervoltage release (>85%); replace undervoltage release if faulty
	Circuit breaker locked in OPEN position	Check reason for lock
	Drawout position interlock is operating; levering screw	Make sure that circuit breaker is at a position that permits closure; door is <i>open</i> check that shutter (door) over the levering screw is fully closed
	Circuit breaker interlocked with another circuit breaker or device	Check for presence of an interlocking scheme (cable interlock or key interlock); check to see if interlocked circuit breaker is CLOSED

Table 7.1 Circuit Breaker Troubleshooting Guide (continued from previous page)

Symptom	Probable Cause	Corrective Actions
Circuit breaker cannot be closed remotely (can be closed locally)	Spring release (closing) coil supply voltage low or spring release faulty	Check power supply voltage; replace spring release if faulty
	Secondary contact wiring problem	Make sure electrical pin and socket connectors are properly seated in molded plug. Verify proper wiring
	Spring release closing coil signal blocked	Clear Digitrip 1150 relay contact
Circuit breaker cannot be closed locally (but can be closed remotely)	Opening and/or closing pushbuttons locked	Check reason for lock
Circuit breaker does not recharge electrically but will recharge manually	Charging motor supply voltage absent or too low (<85%)	Check charging motor electrical circuit voltage (check under load)
	Charging motor faulty	Replace charging motor assembly
Drawout circuit breaker will not lever-in	Circuit breaker will not fully enter cell (cell rejection code plate)	Circuit breaker ratings do not correspond to the cassette requirements
	Levering-in screw not in fully DISCONNECT position at insertion	Rotate levering-in screw counterclockwise to DISCONNECT position, then insert breaker fully into cassette
	Levering-in screw in DISCONNECT position but not pushed in far enough	Push circuit breaker in as far it will go, cover should be flush with front of cassette side plate
	Protective boots covering stationary disconnects	Remove boots
	Shutter jammed or locked	Clear problem

SECTION 8: RENEWAL PARTS

8-1 GENERAL

All renewal parts and/or spare parts recommendations for Type Magnum DS, Magnum DSX and Magnum DSL Circuit Breakers are supplied in separate Renewal Parts Documentation, not this instruction manual. Refer to the most recent version of this documentation for specific assistance.

When ordering parts, always specify, if known, the part name and style number. If the style number is not known, it would help to refer to a pictorial and/or graphic reference. Also include the circuit breaker type, General Order number and other information as shown on the nameplate on the front cover of the circuit breaker (Figures 1-2 and 3-5).

Some detailed parts shown in the figures in this manual may only be available as a part of a sub-assembly. Certain parts may not be available at all for field installation. Some parts in the figures are illustrated just to show their function and location in the assembly. The Renewal Parts Documentation indicates which parts are available and in what form. For additional information, visit the Cutler-Hammer website at www.EatonElectrical.com

This instruction booklet is published solely for information purposes and should not be considered all inclusive. If further information is required, you should consult Cutler-Hammer.

Sale of product shown in this literature is subject to terms and conditions outlined in appropriate Cutler-Hammer selling policies or other contractual agreement between the parties. This literature is not intended to and does not enlarge or add to any such contract. The sole source governing the rights and remedies of any purchaser of this equipment is the contract between the purchaser and Cutler-Hammer.

NO WARRANTIES, EXPRESSED OR IMPLIED, INCLUDING WARRANTIES OF FITNESS FOR A PARTICULAR PURPOSE OR MERCHANTABILITY, OR WARRANTIES ARISING FROM COURSE OF DEALING OR USAGE OF TRADE, ARE MADE REGARDING THE INFORMATION, RECOMMENDATIONS AND DESCRIPTIONS CONTAINED HEREIN. In no event will Cutler-Hammer be responsible to the purchaser or user in contract, in tort (including negligence), strict liability or otherwise for any special, indirect, incidental or consequential damage or loss whatsoever, including but not limited to damage or loss of use of equipment, plant or power system, cost of capital, loss of power, additional expenses in the use of existing power facilities, or claims against the purchaser or user by its customers resulting from the use of the information, recommendations and description contained herein.

Eaton Corporation
1000 Cherrington Parkway
Moon Township, PA 15108-4312
USA
tel: 1-800-525-2000
www.EatonElectrical.com

EAT•N

Cutler-Hammer