



CONTROLS

RENEWAL PARTS ORDERING GUIDE

TYPES LA-600 and LA-600F

AIR CIRCUIT BREAKER

WITH

MANUAL OR ELECTRICAL

OPERATORS

www.ElectricalPartManuals.com

**HOW TO USE YOUR
RENEWAL PARTS ORDERING GUIDE**

1. Locate the part or parts to be replaced in one of the drawings in this manual
2. Identify each part by item number, description and part number. Give drawing figure number in which part is shown.
3. Include breaker type, rating and breaker serial number with your order.
4. Place order with your Allis-Chalmers representative.
5. When ordering relays or other electrical parts, include control voltage (see recommended spare parts list for part numbers).

ORDERING EXAMPLE

Type	<u>LA-600</u>	Rated Amps	<u>600</u>	Serial Number	<u>H-66679A-4</u>
Mode of Operation:	<input checked="" type="checkbox"/> Electrical		<input type="checkbox"/> Manual		
Renewal Parts Ordering Guide					
<u>Fig</u>	<u>Item</u>	<u>Description</u>	<u>Part Number</u>	<u>Quantity</u>	
1	5	Support	71-141-916-001	1	
3	44	Arc Runner	71-141-983-001	2	
2	11	Pawl	72-140-062-002	1	

If required part is not identified in this manual -----

1. Make a copy of the drawing figure in which the part would appear.
2. Indicate with arrows or other markings location of part.
3. Describe or sketch required part.
4. Include breaker type, rating and breaker serial number with your order.
5. Place order with your Allis-Chalmers representative.

TABLE OF CONTENTS

	<u>Drawing No.</u>	<u>Figure</u>	<u>Page</u>
Air Circuit Breaker	18-384-441-602	1	
Operator Mechanism	18-465-970-501	2	
Panel Assembly	18-657-346-522	3	

USAGE CODE TABLE

Type	Application	Operator	Top Level Assembly	Usage Code*
LA-600	600 AMP	Manual	18-384-441-601	A
LA-600	600 AMP	Electrical	18-384-441-602	B
LA-600	600 AMP	Electrical/Manual	18-384-441-603	C
LA-600	600 AMP	Manual-Fused	18-384-441-611	D
LA-600	600 AMP	Electrical-Fused	18-384-441-612	E
LA-600	600 AMP	Electrical/Manual Fused	18-384-441-613	F

* If no usage code appears in the "USAGE" column of the following parts lists, the part is used on all assemblies listed in the figure title.

www.ElectricalPartManuals.com

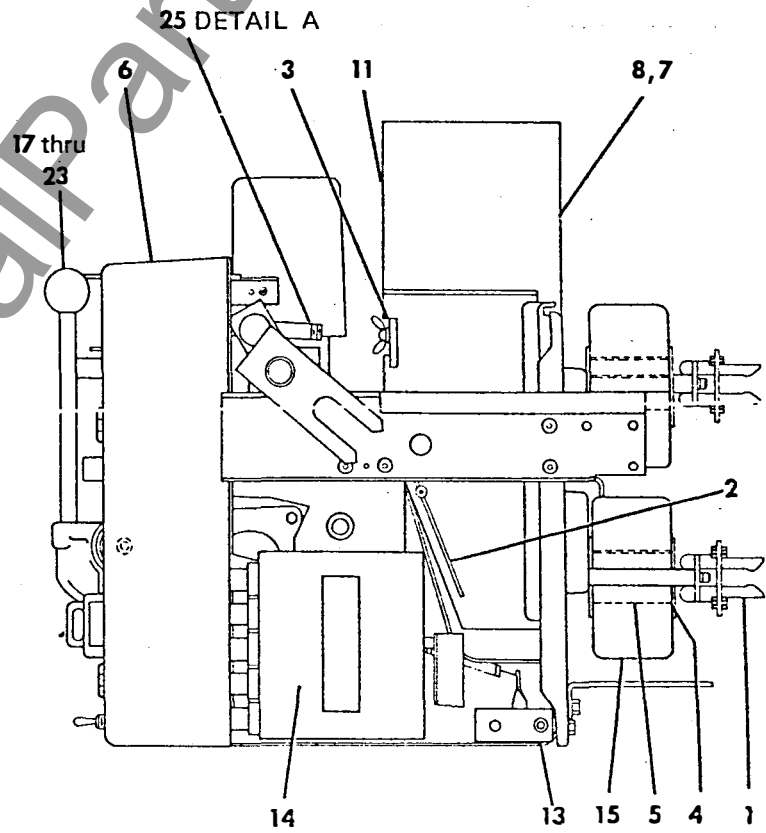
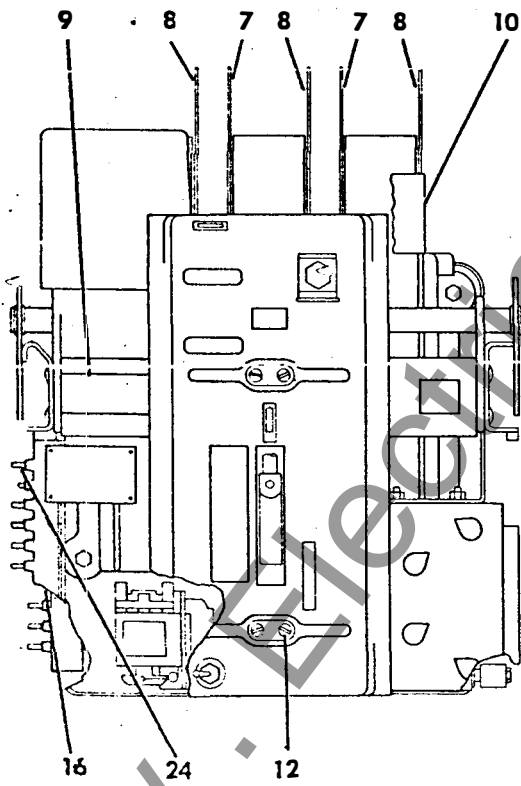
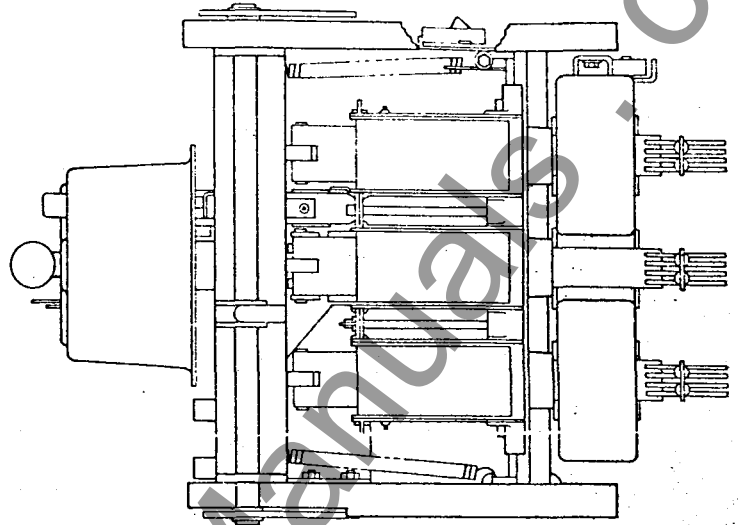
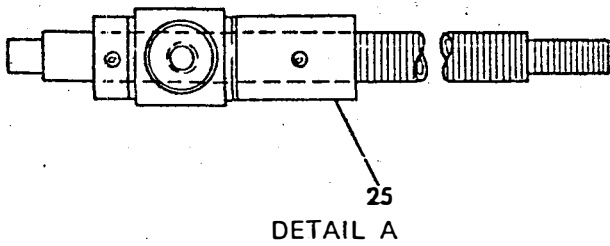

Figure 1. Air Circuit Breaker (18-384-441-602)

www.ElectricalPartManuals.com

ITEM	DESCRIPTION	PART NUMBER	USAGE
1	Contact Finger Assembly	71-240-055-509	
2	Barrier	71-142-008-001	
3	Strap	71-141-841-001	
4	Washer	71-141-915-001	
5	Support	71-141-916-001	
6	Cover Assembly	18-657-346-523	A
6	Cover Assembly	18-657-346-579	B
6	Cover Assembly	18-657-359-558	C
6	Cover Assembly	18-657-346-581	D
6	Cover Assembly	18-657-349-551	E
6	Cover Assembly	18-657-364-568	F
7	Barrier	71-141-838-001	
8	Barrier	71-141-838-002	
9	Decal	71-141-867-001	
10	Belt Assembly	72-140-031-501	
11	Arc Chute Assembly	18-657-346-524	
12	Screw	00-615-203-216	
13	Operator Mechanism	See Fig. 2 & 3	
14	Static Trip	*	
15	Tripping Current Transformers	**	
16	Base Assembly	72-240-028-501	
17	Manual Handle Assembly (Includes items 17 thru 23)		
18	Cam Assembly	18-657-340-515***	
19	Handle Assembly	18-657-346-516***	
20	Pin	71-240-127-016***	
21	Retaining Ring	00-673-165-037***	
22	Set Screw	00-617-031-413***	
23	Spring	71-141-761-001***	
24	Contact Finger	71-142-169-001	
25	Racking Screw Assembly	18-657-426-880	

* When ordering replacement, give nameplate data, type, time band if applicable (e.g. "MAX", "INT", or "MIN" as indicated by white dot or "X").

** When ordering trip current transformers, give part number shown on tag, on original current transformer or breaker trip rating.

*** NOTE: Manual handle is not standard on electrically operated breakers. Total assembly if replaced is Part No. 74-142-152-503.

Figure 1. Air Circuit Breaker (18-384-441-602)

www.ElectricalPartManuals.com

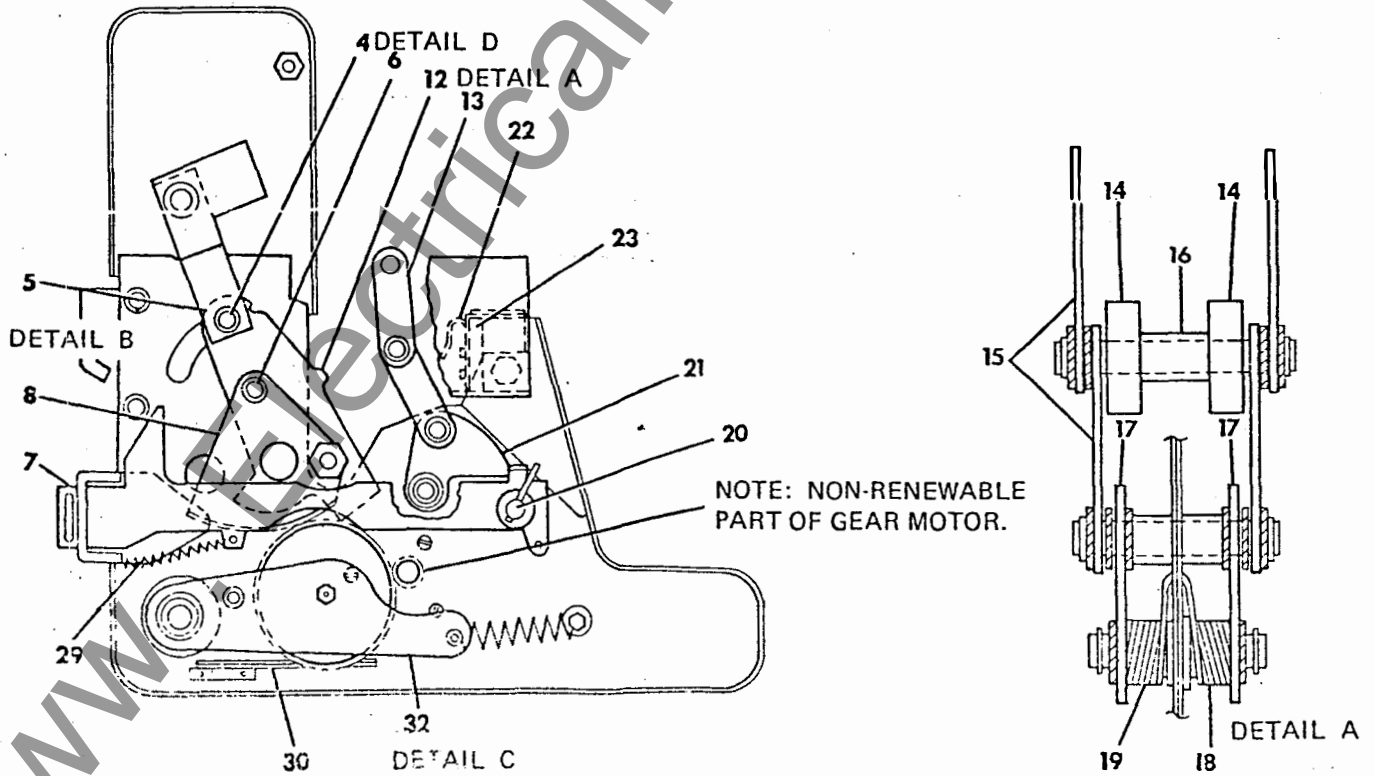
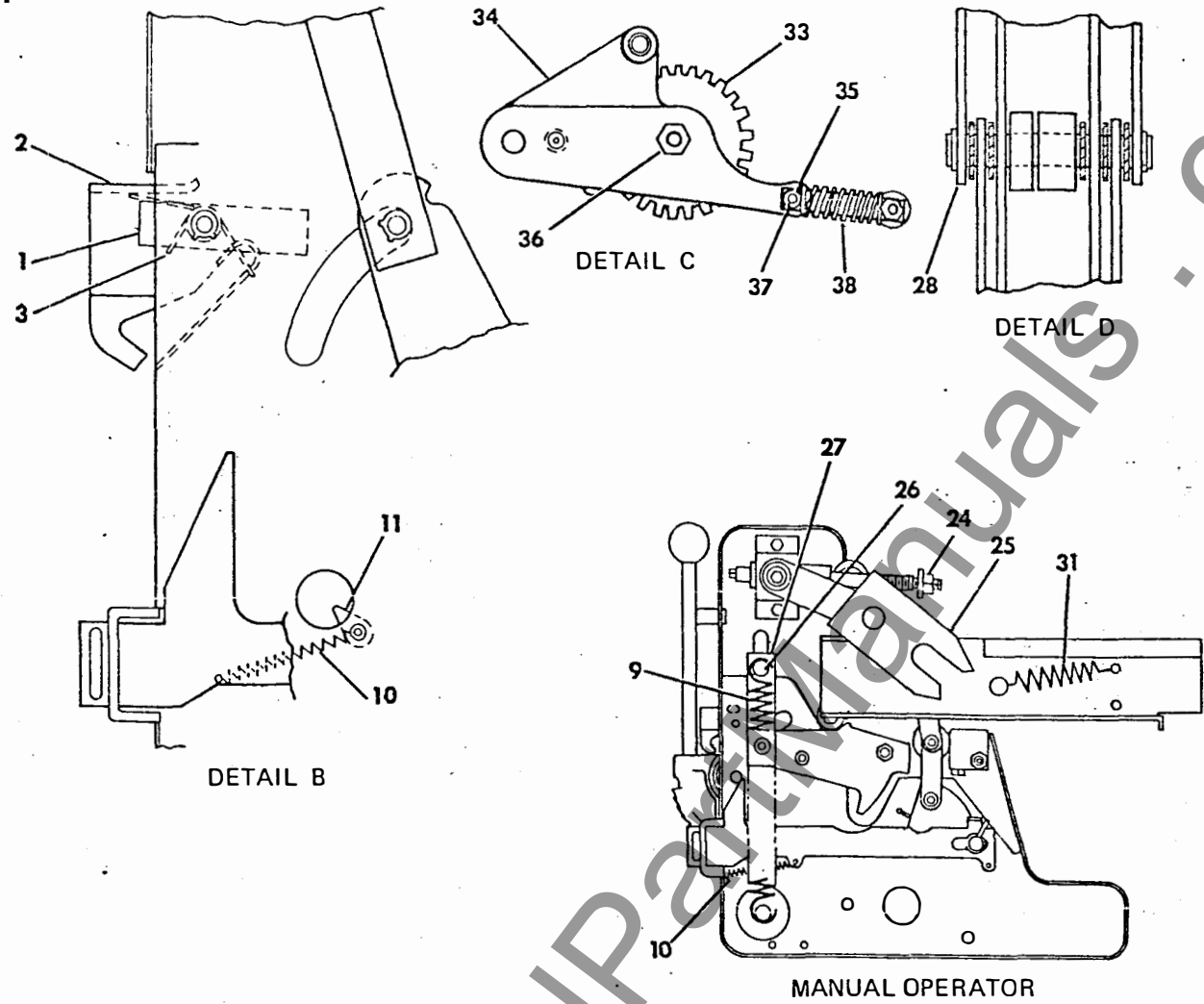

Figure 2. Operator Mechanism (18-465-970-501)

www.ElectricalPartManuals.com

ITEM	DESCRIPTION	PART NUMBER	USAGE
1	Spring Release Latch	71-142-409-002	
2	Channel	71-142-407-001	
3	Spring	71-142-406-001	
4	Pin	71-240-127-017	
5	Roller Bearing	00-813-109-037	
6	Pin	71-141-823-001	
7	Trip Shaft Assembly	18-657-345-579	
8	Gear Segment	71-141-777-001	
9	Spring	71-141-836-001	
10	Spring	71-141-266-001	
11	Pawl	72-140-062-002	
12	Cam	71-141-782-001	
13	Toggle Linkage Assembly (Includes items 14 thru 16)	18-657-345-581	
14	Roller	71-141-789-003	
15	Link	71-141-791-001	
16	Spacer	71-141-828-006	
17	Spacer	71-141-828-001	
18	Spring	71-141-833-001	
19	Spring	71-141-833-002	
20	Trip Shaft	72-240-007-001	
21	Trip Latch	71-141-793-001	
22	Spring Assembly	18-657-345-580	
23	Bumper	71-141-776-001	
24	Nut	71-142-155-001	
25	Clevis	72-140-015-401	
26	Racking Screw	72-140-039-501	
27	Pin	71-141-827-001	
28	Link	71-141-790-002	
29	Link Assembly	18-657-359-552	
30	Spring	18-657-346-578	
31	Spring	71-141-813-001	
32	Gear Train Assembly (Includes items 33 thru 38)	18-657-346-577	
33	Gear Assembly	71-141-860-501	
34	Arm Assembly	71-141-977-501	
35	Link	71-141-851-001	
36	Bearing	71-141-864-001	
37	Pin	71-141-865-001	
38	Spring	00-837-321-027	

Figure 2. Operator Mechanism (18-465-970-501)

www.ElectricalPartManuals.com

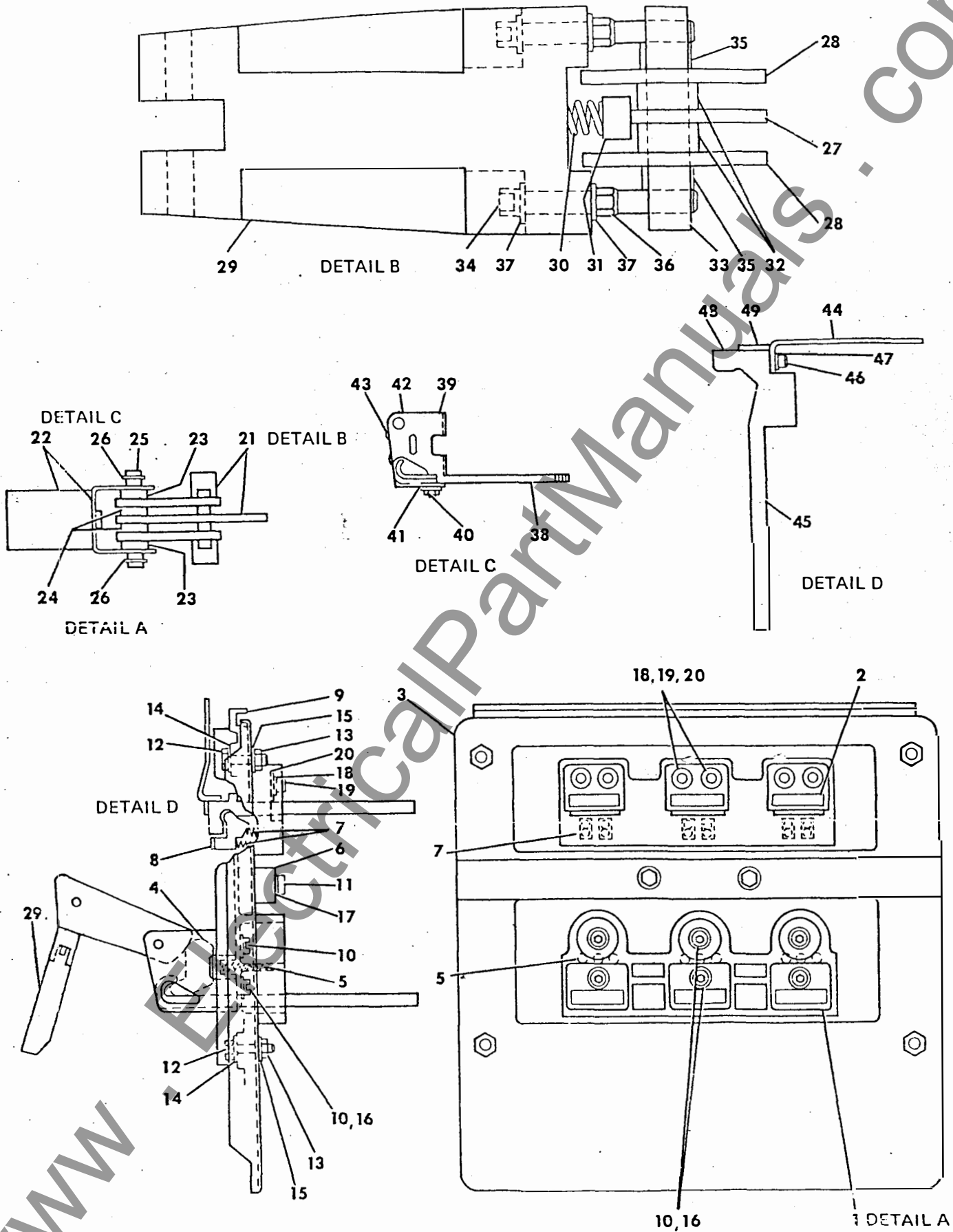

Figure 3. Panel Assembly (18-657-346-522)

www.ElectricalPartManuals.com

ITEM	DESCRIPTION	PART NUMBER	ITEM	DESCRIPTION	PART NUMBER
1	Conn & Clevis Ass'y. (Includes items 21 thru 26)	18-657-346-521	23	Spacer	71-141-822-002
2	Conn. Ass'y.	18-657-346-520	24	Spacer	71-141-822-003
3	Pan	71-240-525-001	25	Pin	71-141-823-001
4	Contact	71-141-768-001	26	Retainer Ring	00-673-165-037
5	Spring	71-141-930-001	27	Arcing Contact Ass'y.	71-141-803-501
6	Bar	71-141-832-001	28	Main Contact Ass'y.	71-141-805-501
7	Spring	71-141-976-001	29	Clevis	71-240-542-001
8	Contact Finger Ass'y.	71-141-973-501	30	Spring	71-141-799-001
9	Base	71-440-117-001	31	Spring Guide	71-141-975-001
10	Screw	00-615-114-375	32	Spacer	71-141-822-003
11	Screw	00-611-315-422	33	Pin	71-141-921-001
12	Screw	00-611-315-468	34	Screw	00-615-114-386
13	Jam Nut	00-631-171-106	35	Spacer	71-142-182-001
14	Washer	00-651-007-214	36	Elastic Stop Nut	00-633-025-116
15	Lockwasher	00-655-017-032	37	Washer	00-651-007-909
16	Lockwasher	00-655-067-140	38	Connector	71-141-786-001
17	Lockwasher	00-655-017-030	39	Support Ass'y.	71-142-172-501
18	Lockwasher	00-655-017-026	40	Screw	00-611-289-373
19	Screw	00-615-114-380	41	Washer	00-655-017-026
20	Washer	00-651-007-146	42	Support	71-141-794-001
21	Clevis Ass'y. (Includes items 27 thru 37)	18-657-346-517	43	Pem Fastener	00-673-115-422
22	Connector Ass'y. (Includes items 38 thru 43)	18-657-346-518	44	Arc Runner	71-141-983-001
			45	Connector Ass'y.	71-141-769-502
			46	Screw	00-615-124-218
			47	Washer	00-655-017-022
			48	Connector	71-141-771-001
			49	Contact	71-141-772-003

Figure 3. Panel Assembly (18-657-346-522)

www.ElectricalPartManuals.com