



plug-in low impedance bus duct

application data

30-567

page 1

straight lengths, fittings, plug-in protective devices, hangers

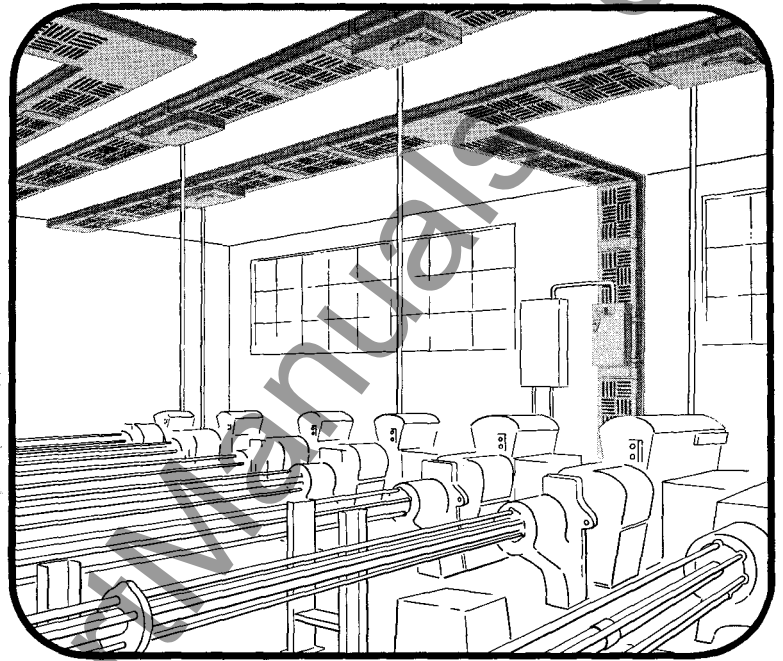
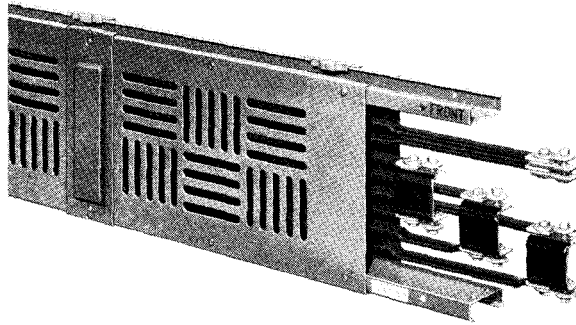

in this section:

description	page	description	page
general information	2	plug-in protective devices	
straight lengths (10 ft. sections)		circuit breaker plug-ins	12, 13
10 foot section	3	safety switch plug-in type T.A.P.	14
construction details	3	combination linestarter plug-in	15
duct joint	3	ground detector and neutralizer plug-in	15
fittings		hangers	
flange sections	4	cantilever and "C" type	16
elbows	5	channel hangers	16
tees	6	hangers for vertical mounting	16
crossovers	7	engineering and test data	
offsets	7	dimensions and weights	17
elbow flanges	8, 9	voltage drop table	18
expansion sections	9	typical specifications	18, 19
end closers	9		
adapter cubicles	10		
reducers	10		
DB breaker cubicles	11		
pressure type switches	11		

June, 1965

supersedes application data 30-667, pages 1-20, dated November, 1961
 mailed to: E/1136/DB; D/808/DB; C/315/AD



general information

10 foot section of plug-in low impedance bus duct with ventilated housing

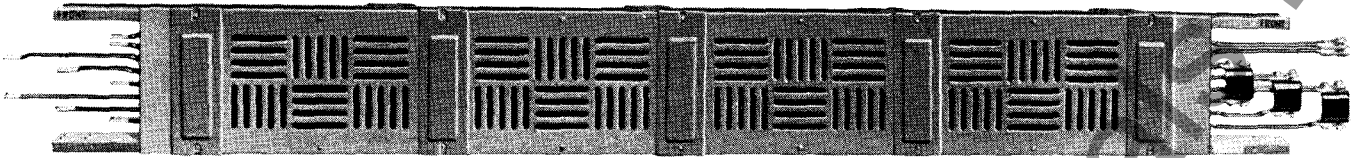

application

Plug-in low impedance bus duct is used to conduct large amounts of power over long distances with a minimum voltage drop and provide frequent tap-off locations for power and lighting loads. It consists of insulated copper or aluminum bars, closely spaced, supported by combination clamp type, plug-in supports. These are enclosed in a 16-gauge steel housing, utilizing the 4-channel interlocking type construction.

Plug-in low impedance duct is available in ventilated and totally enclosed indoor housings. For most applications a totally enclosed housing is not necessary since the bus bars are fully insulated, (except for short space at the splice between sections where uninsulated portions are staggered) therefore, ventilated bus duct is usually specified.

note: Plug-in low impedance feeder duct is also available where plug-in openings are not required. It is interchangeable with plug-in low impedance of the same rating.

construction

Plug-in low impedance bus duct is applicable to 2-wire, 3-wire, 4-wire half and 4-wire full neutral systems. All hardware used in assembling bus duct is zinc chromate plated. Special fasteners (bolts with shakeproof washers permanently attached) are used to join sections of duct. The fasteners are inserted into drawn, threaded holes in the housing, providing a rigid mechanical connection between all sections of a system.

Bus bars are insulated their entire length with polyvinyl chloride plastic tubing and are silver plated at

splice ends and plug-in openings, to provide a good electrical contact. Captive bolts and lockwashers are provided on the right end of each section for making bus bar joints. Slots are provided in bus bars at the left end of each section to simplify installation. Tie straps are also installed on the right end of each section to equalize the load. Bolts for bus bar splices are heat-treated zinc chromate plated steel bolts having a tensile strength of 100,000 lbs. per square inch.

Bus bars of all ratings using two bars per phase are insulated and firmly supported on 1-inch centers by moulded plug-in type glass polyester supports spaced at 24-inch intervals. All plug-in outlets can be used simultaneously. 10-ft. sections of bus duct using 2½-inch thru 7-inch bus bar size have a total of 10 plug-in outlets (5 on each side of duct on same centerline). 10-ft. sections of bus duct using 1-inch thru 2-inch bus bar size have a total of 10 plug-in outlets (5 on each side of duct slightly offset with respect to each other). Bus bars on non plug-in fittings, tees, elbows, etc., are firmly supported on ¾-inch centers by moulded glass polyester supports. Spring retained, sliding-plate type outlet covers are provided for each plug-in opening. For reduced reactance, bus bars of opposite polarity are interlaced to provide a repeating phase sequence.

standards

Westinghouse plug-in low impedance bus duct is manufactured to withstand short circuit stresses in accordance with NEMA short circuit ratings for busways. These ratings are listed on page 9 A.D. 30-660. All ratings have the Underwriters Laboratories, Inc., listing unless noted otherwise.

straight lengths

10 foot section top and front views

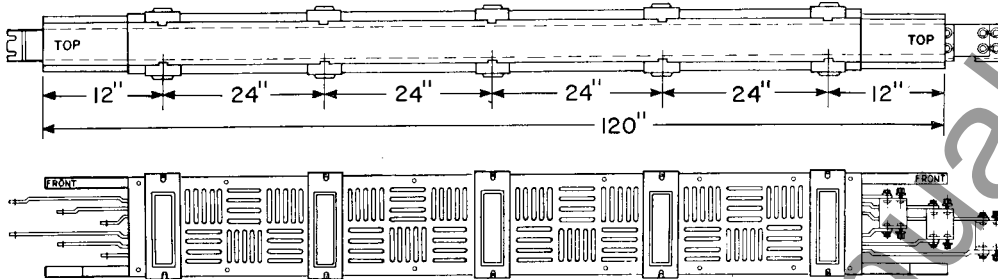

construction details

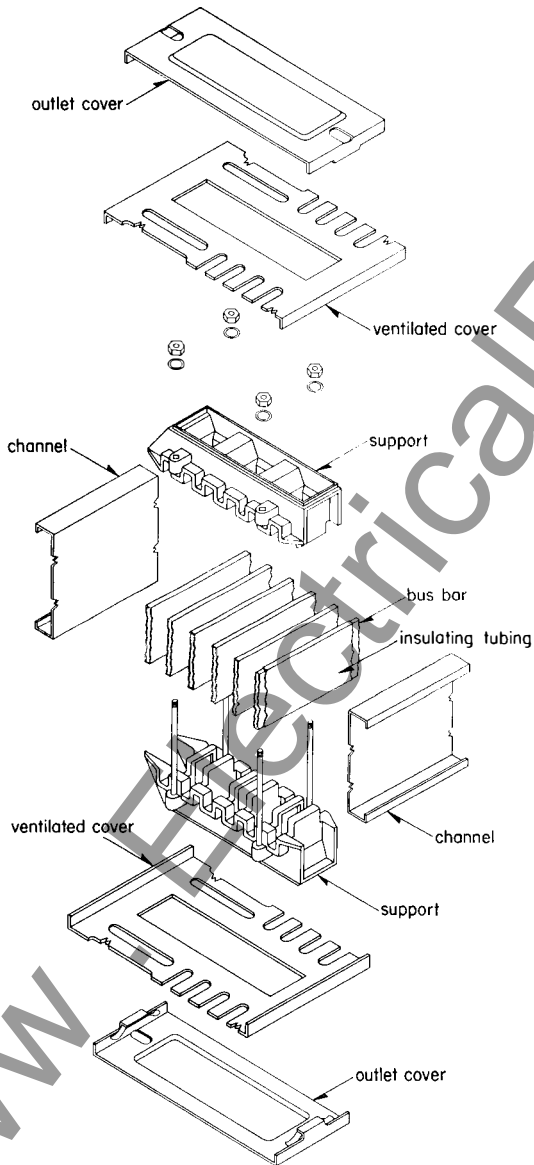

duct joint

For ease of inspection of bus bar joints and to facilitate ease of installation, access openings to bolted joints are provided on opposite sides of the duct. This affords ample room for bolting of bus bars. After bolted joint is made, an access cover 14 inches long covers this opening.

Bus bars are provided with captive bolts on one end and slots at the other for ease in making splices. Heavy 14-gauge steel splice plates telescope inside the top and bottom channels. They are attached by Semes fasteners, insuring a strong mechanical connection between housings of adjoining sections.

duct joint details

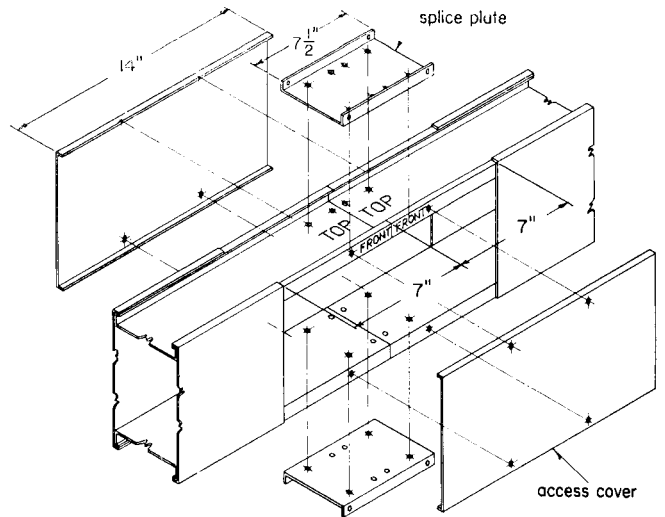



fittings

There are ten basic fittings to meet every application need. These include: flange ends, elbows, tees, offsets, crossovers, reducers, adapter cubicles, expansion sections, cable tap boxes, and end closers. They, along with standard and minimum dimensions are described on the following pages. When making field measurements and layouts, it should be remembered that dimensions of fittings such as elbows, tees, offsets, and crossovers are given from the centerline of the duct.

flange sections

Flange sections are used to make mechanical and electrical connection of busway to other apparatus. Flanges join bus duct housing to the switchgear or switchboard while specially fabricated bus bar extensions connect to the bus work of the apparatus.

When bus duct extends out of switchgear the opening and flange drillings must be provided by the switchgear builder. In which case, the cutout dimensions and drilling plan must be followed. For proper coordination between bus duct and switchgear, detailed drawings must accompany the order.

Standard bus extensions are eight inches long and phase bars are brought together in the housing before extending through the flange. Flange and bus extension sections are fabricated for either right or left connection to the duct system. Viewing the "FRONT" of the duct system with the "TOP" marking up, the right flange section joins to the right and the left joins to the left end of the system.

copper	aluminum	bus bar size	minimum "X" dimension	maximum "X" dimension	standard length
800	600	2-1/4" x 1"	16 1/2	54	24
1000	800	2-1/4" x 1 1/2"	17	54	24
*1350	*1000	2-1/4" x 2"	17 1/2	54	24
*1600	*1350	2-1/4" x 2 1/2"	18	54	24
*2000	*1600	2-1/4" x 3"	18 1/2	54	24
*2500	*2000	2-1/4" x 4"	19 1/2	54	24
*3000	2-1/4" x 5"	20 1/2	54	24
.....	*2500	2-1/4" x 6"	21 1/2	54	24
*4000	*3000	2-1/4" x 7"	22 1/2	54	24

* For flatwise mounting only.

key to relationship of fittings to straight lengths

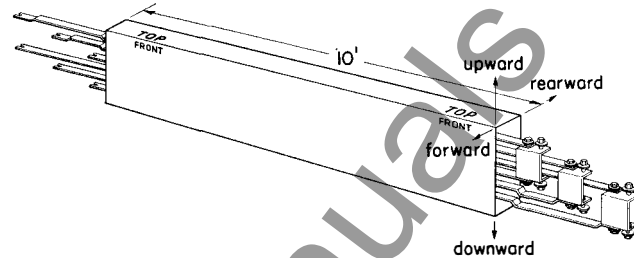

3 Ø/4W/FN

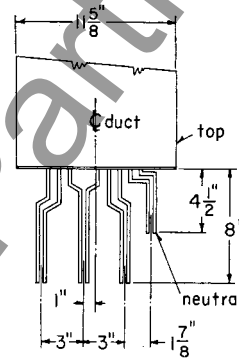

3 Ø/4W/1/2N

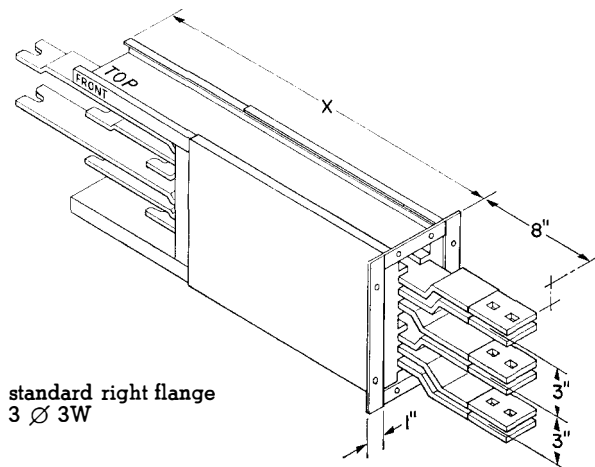
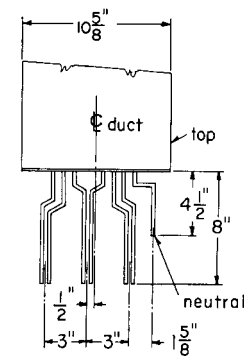

standard right flange
3 Ø 3W

elbows

Elbows are used to make 90° changes in the direction of busway runs. There are four types available with each leg of the standard elbow being 24-inches long.

upward and downward elbows

forward and rearward elbows

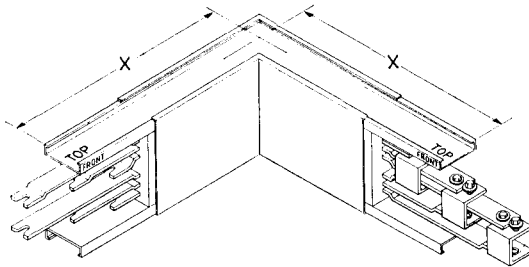

forward elbow

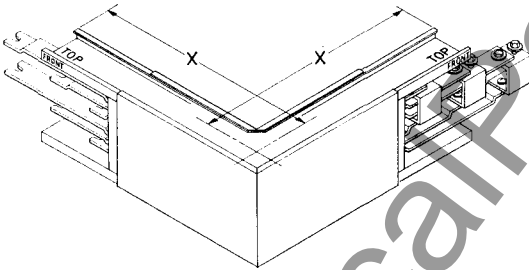

rearward elbow

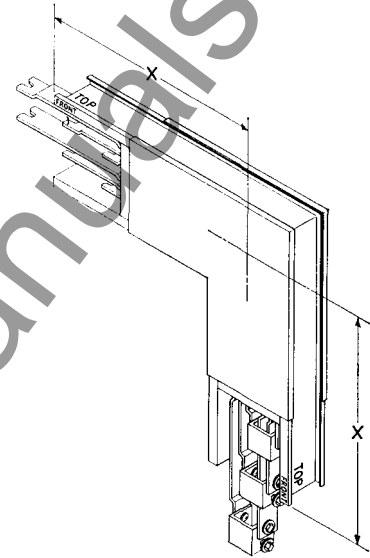

downward elbow

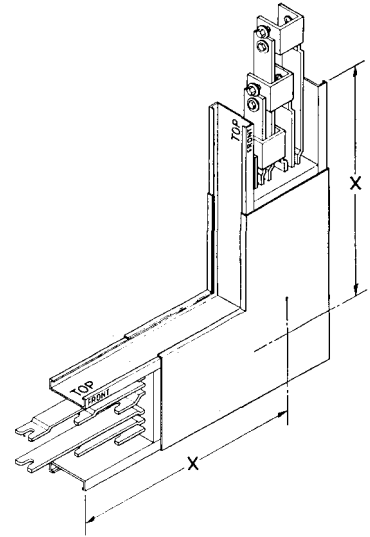

upward elbow

copper	aluminum	bus bar size	minimum "X" dim. left or right leg	maximum "X" dim. left or right leg
800	600	2-1/4 x 1	11 1/2	50
1000	800	2-1/4 x 1 1/2	12	50
*1350	*1000	2-1/4 x 2	12 1/2	50
*1600	*1350	2-1/4 x 2 1/2	12 3/4	50
*2000	*1600	2-1/4 x 3	13	50
*2500	*2000	2-1/4 x 4	13 1/2	50
*3000	.	2-1/4 x 5	14	50
....	*2500	2-1/4 x 6	14 1/2	50
*4000	*3000	2-1/4 x 7	15	50

* For flatwise mounting only.



fittings

tees

Tees are busway fittings for making T connections to bus duct. The four standard tees for plug-in low-impedance duct are: forward, rearward, upward, and downward. Each leg of a standard tee is 24-inches long, measured from the centerline of the duct to the end of the top or bottom channels.

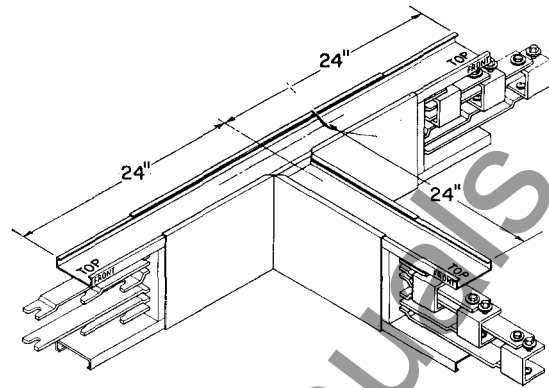

forward tee

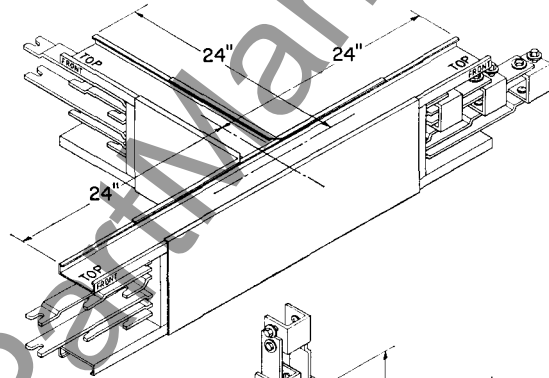

rearward tee

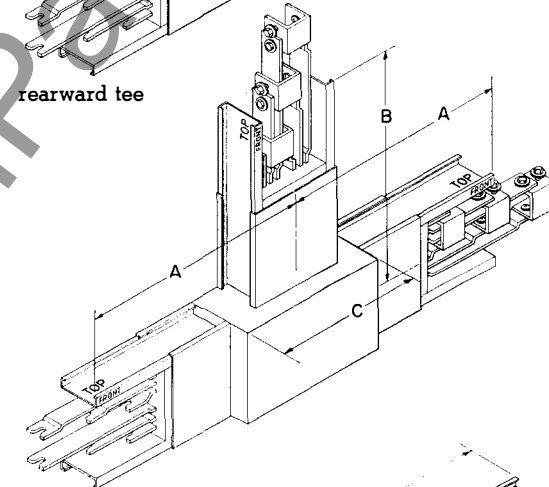

upward tee

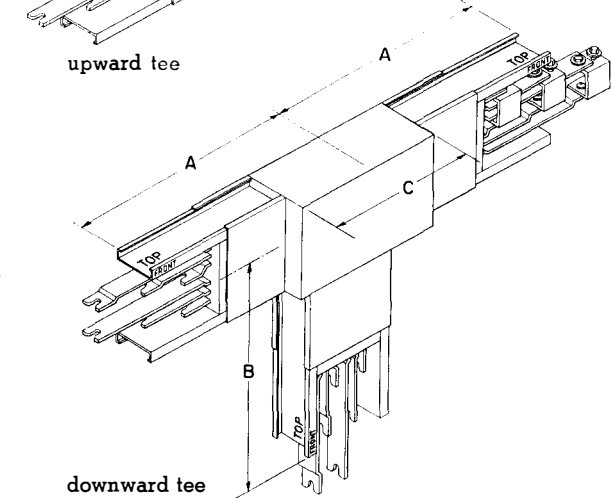

downward tee

forward and rearward tees

Facing the "FRONT" with the marking "TOP" upward, a 24-inch leg extends forward on a forward tee and rearward on a rearward tee from the center of a four foot section of duct.

amp ratings		bar size	minimum leg lengths
copper	aluminum		
800	600	2-1/4 x 1	13 1/4
1000	800	2-1/4 x 1 1/2	13 1/2
*1350	*1000	2-1/4 x 2	13 3/4
*1600	*1350	2-1/4 x 2 1/2	14
*2000	*1600	2-1/4 x 3	14 1/4
*2500	*2000	2-1/4 x 4	14 3/4
*3000		2-1/4 x 5	15 1/4
*3500	*2500	2-1/4 x 6	15 3/4
*4000	*3000	2-1/4 x 7	16 1/4

upward and downward tees

Upward tees have a 24-inch leg extending upward from the center of a 4-foot section of duct with the "TOP" marking up. With the "TOP" marking up, downward tees have a 24-inch leg extending downward from the center of a 4-foot section of duct.

amp ratings		bar size	minimum leg dimension								
copper	aluminum		3Ø3W			3Ø4W 1/2N			34ØW F/N		
			A	B	C	A	B	C	A	B	C
800	600	2-1/4 x 1	16 1/4	15 1/4	11	16 1/4	16 1/4	11	17 1/4	16 1/4	13
1000	800	2-1/4 x 1 1/2	16 3/4		12	16 3/4	12	17 3/4		14	
*1350	*1000	2-1/4 x 2	17 1/4		13	17 1/4	13	18 1/4		15	
*1600	*1350	2-1/4 x 2 1/2	17 3/4		14	17 3/4	14	18 3/4		16	
*2000	*1600	2-1/4 x 3	18 1/4		15	18 1/4	15	19 1/4		17	
*2500	*2000	2-1/4 x 4	19 1/4		17	19 1/4	17	20 1/4		19	
*3000		2-1/4 x 5	24		19	24	19	24		21	
.....	*2500	2-1/4 x 6	24		21	24	21	24		23	
*4000	*3000	2-1/4 x 7	24		23	24	23	24		25	

* For flatwise mounting only.

CROSS

A cross is a busway fitting suitable for connection in four directions. It is used where two runs of duct intersect each other in the same plane. There are two types: the forward-rearward and the upward-downward. Each leg is two feet long.

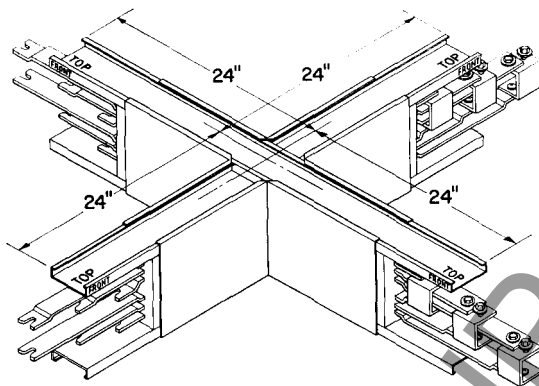

forward-rearward

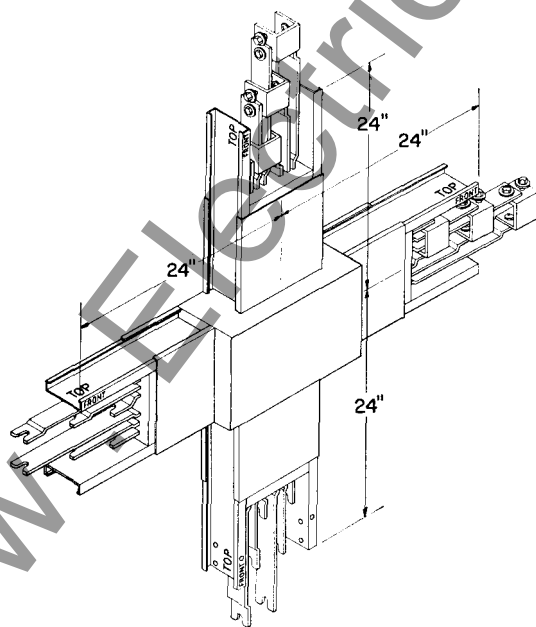

upward-downward

offsets

An offset is used to avoid obstacles and to conform with building structure. It is simply two elbows fabricated into one unit for use where it is impossible to use a standard elbow because of space restrictions. The minimum left and right leg dimensions are the same as those listed for similar type elbows.

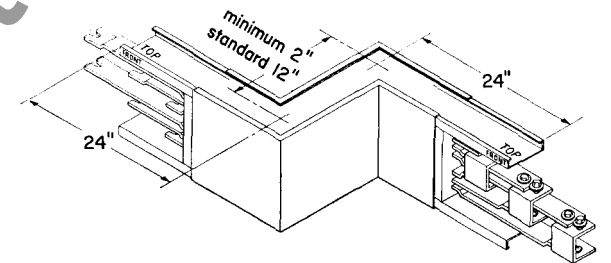
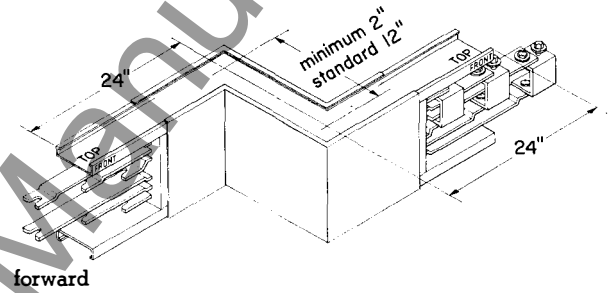

rearward

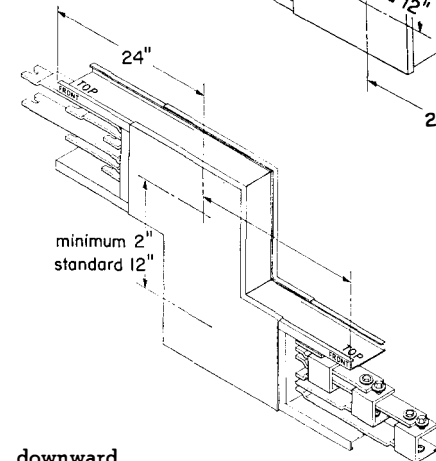
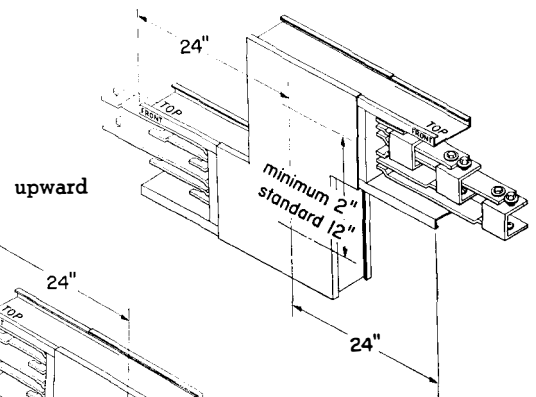

downward



fittings

elbow flanges

forward and rearward elbow right or left flange

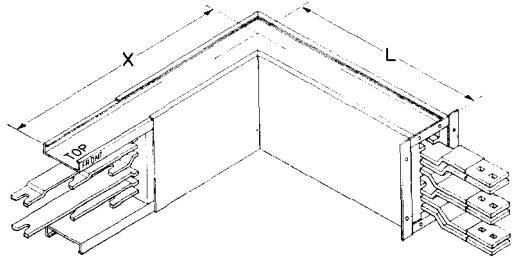

forward elbow right flange

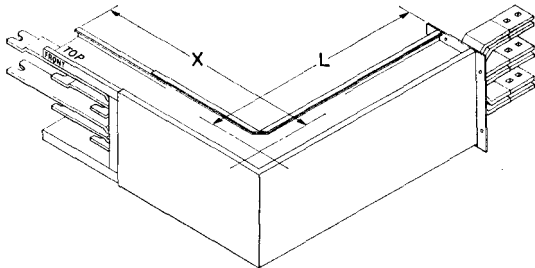

rearward elbow right flange

upward and downward elbow flange

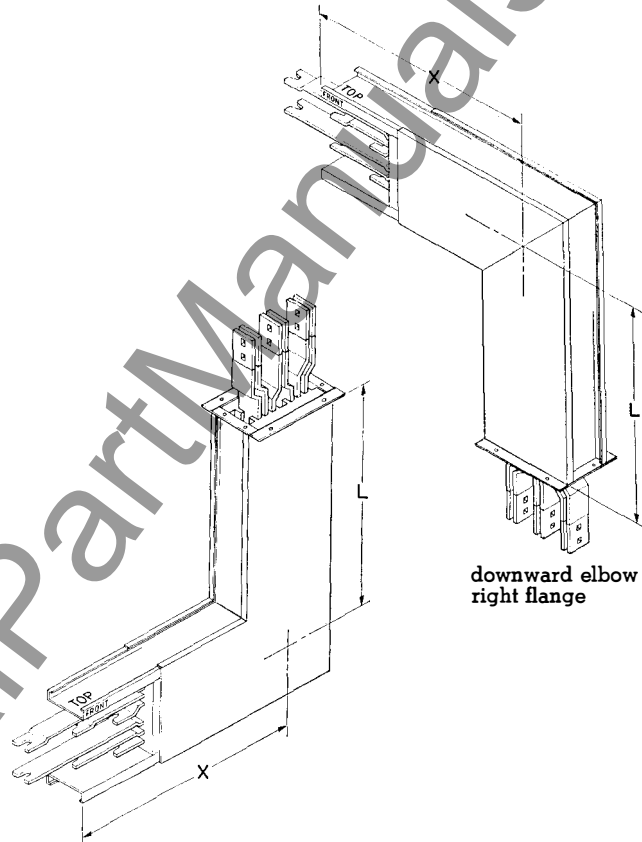

downward elbow right flange

upward elbow right flange

copper	aluminum	bus bar size	flange leg		elbow leg	
			minimum "L" dimension	maximum "L" dimension	minimum "X" dimension	maximum "X" dimension
800	600	2-1/4 x 1	9	52 3/8	11 1/2	59 7/8
1000	800	2-1/4 x 1 1/2	9 1/2	52 3/8	12	59 7/8
*1350	*1000	2-1/4 x 2	10	52 3/8	12 1/2	59 7/8
*1600	*1350	2-1/4 x 2 1/2	10 1/2	52 3/8	12 3/4	59 7/8
*2000	*1600	2-1/4 x 3	11	52 3/8	13	59 7/8
*2500	*2000	2-1/4 x 4	12	52 3/8	13 1/2	59 7/8
*3000	2-1/4 x 5	13	52 3/8	14	59 7/8
.....	*2500	2-1/4 x 6	14	52 3/8	14 1/2	59 7/8
*4000	*3000	2-1/4 x 7	15	52 3/8	15	59 7/8

* For flatwise mounting only.
Flanges can be supplied on end of right or left leg as required.

copper	aluminum	bus bar size	flange leg		elbow leg	
			minimum "L" dimension	maximum "L" dimension	minimum "X" dimension	maximum "X" dimension
800	600	2-1/4 x 1	14 3/4	52 1/8	15 3/4	45
1000	800	2-1/4 x 1 1/2	15 1/4	52 1/8	15 3/4	45
*1350	*1000	2-1/4 x 2	15 3/4	52 1/8	15 3/4	45
*1600	*1350	2-1/4 x 2 1/2	16 1/4	52 1/8	15 3/4	45
*2000	*1600	2-1/4 x 3	16 3/4	52 1/8	15 3/4	45
*2500	*2000	2-1/4 x 4	17 3/4	52 1/8	15 3/4	45
*3000	2-1/4 x 5	18 3/4	52 1/8	15 3/4	45
.....	*2500	2-1/4 x 6	19 3/4	52 1/8	15 3/4	45
*4000	*3000	2-1/4 x 7	20 3/4	52 1/8	15 3/4	45

* For flatwise mounting only.

www.criticalpartmanuals.com

flush elbow flange

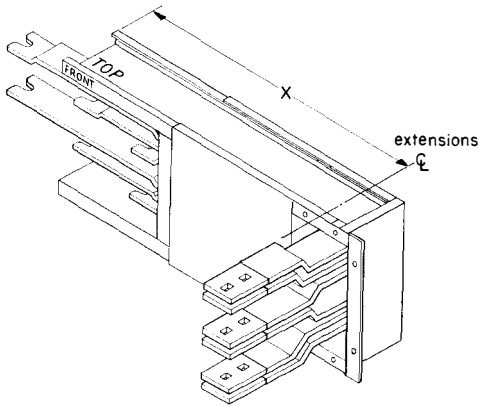

copper	aluminum	bus bar size	minimum "X" dimension	maximum "X" dimension
800	600	2-1/4 x 1	15 3/4	63 1/2
1000	800	2-1/4 x 1 1/2	16	63 1/2
*1350	*1000	2-1/4 x 2	16 1/4	63 1/2
*1600	*1350	2-1/4 x 2 1/2	16 1/2	63 1/2
*2000	*1600	2-1/4 x 3	16 3/4	63 1/2
*2500	*2000	2-1/4 x 4	17 1/4	63 1/2
*3000	2-1/4 x 5	17 3/4	63 1/2
	*2500	2-1/4 x 6	18 1/4	63 1/2
*4000	*3000	2-1/4 x 7	18 3/4	63 1/2

* For flatwise mounting only.

Flange can be supplied on left or right end of section as required.

expansion sections

Expansion sections accommodate the expansion and contraction of bus bars with respect to the enclosure. They are necessary in long, straight runs to compensate for the difference in the coefficient of expansion of steel and copper or aluminum.

They are seven foot sections of duct in which the steel housings contain sliding telescopic joints to allow movement of the housings. Inside the telescopic joints lengths of rigid bus bars are replaced by flexible braid surrounded with ebony asbestos.

An expansion section should be installed in the

center of any horizontal run of 150 feet or more of copper or of 100 feet or more of aluminum duct. If such a run has an end closer at one end, so that the bus bars are free to move, the expansion section may be omitted. When duct is installed in a vertical position, as in tall commercial buildings, expansion sections should be used at every 150 feet of vertical rise. Also, they *must* be used wherever a run of duct crosses an expansion joint in the building. The use of expansion sections should be engineered for individual installations.

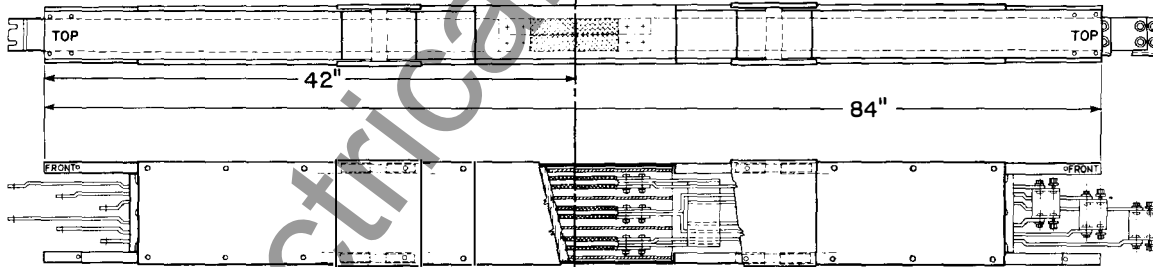

end closers

An end closer is a fitting which terminates the busway run and closes the end. It comes complete with two splice plates and two access covers and is designed to be used on either end of duct. The effective length of an end closer is 7 3/4" and the width is the same as the rating of duct involved.

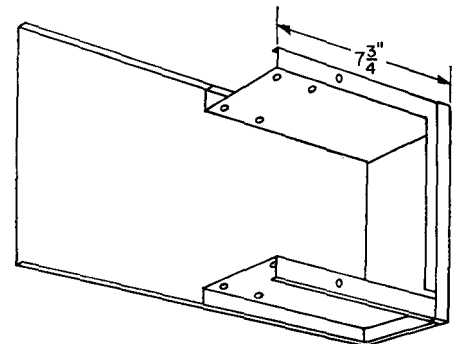



fittings

adapter cubicles

In many instances, it is economical to reduce the ampere rating of the duct as the load drops off. In this case, whenever the rating is reduced more than two-thirds of the rating of the overcurrent protection next back on the line or the length of the reduced run is over 50 feet an overcurrent protective device must be used to meet NEC requirements.

Adapter cubicles are available with either a circuit

breaker or fused non-automatic circuit breaker to furnish overcurrent protection and serve as a disconnecting means. Reduction in bus capacity is made within the cubicle. The line side of the cubicle is connected to the large rating of duct and the load side to the reduced rating of duct. These cubicles may also be used when adapting from plug-in low impedance to other types of bus duct.

circuit breaker adapter cubicles

Overall length of circuit breaker cubicles using the type MA breaker, is 60 inches. Facing the "FRONT" of a left cubicle with the marking "TOP" up, the larger size duct is on the right end or the line side and the smaller size duct is on the left end or load side of the cubicle. Viewing the "FRONT" of a right cubicle with the marking "TOP" up, the larger size duct is on the left end or the line side of the cubicle, while the smaller size duct is on the right end or load side.

safety switch adapter cubicles

Fused disconnect cubicles consist of a nonautomatic circuit breaker with fuse clips built into a 6'0" section of duct. These units are similar in appearance to the circuit breaker cubicle shown on this page. For complete information refer to Westinghouse.

reducers

Reducers are used to reduce the capacity of bus duct without overcurrent protective devices. They are built into a 36-inch section of duct.

No overcurrent protection is required where bus duct is reduced in size provided the length of the smaller duct does not extend more than 50 feet and has a current rating at least 1/3 that of the breaker next back on the line.

left reducer: If, when facing the "FRONT" of a bus duct run with marking "TOP" up, one desires to reduce the capacity of the run at its left end, a left reducer is used. Viewing the "FRONT" of a left reducer the larger size bars are on the right and the smaller size bars on the left.

right reducer: A right reducer is used to reduce the capacity of the run at its right end when viewing the "FRONT" of a bus duct run with marking "TOP" up. Facing the "FRONT" of a right reducer the bus bars are reduced from left to right.

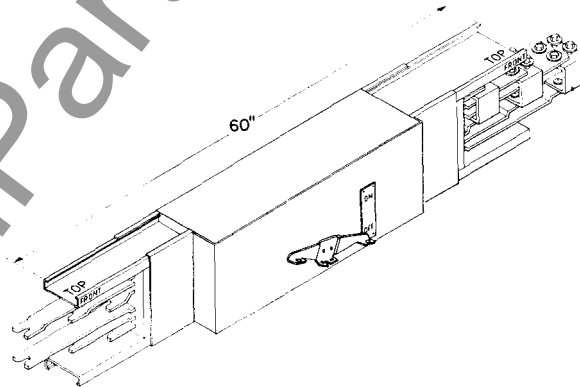

left circuit breaker cubicle

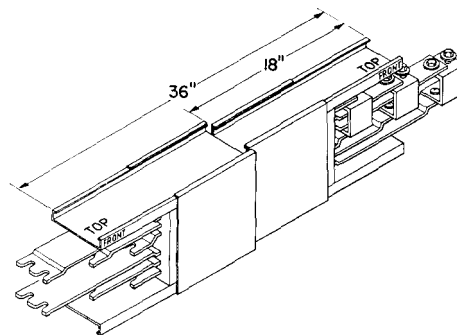

right reducer

cable tap boxes

Cable tap boxes are used where a run of duct is fed by cable and conduit or where equipment served by the duct is connected without overcurrent protection. There are two types of cable tap boxes: the end cable

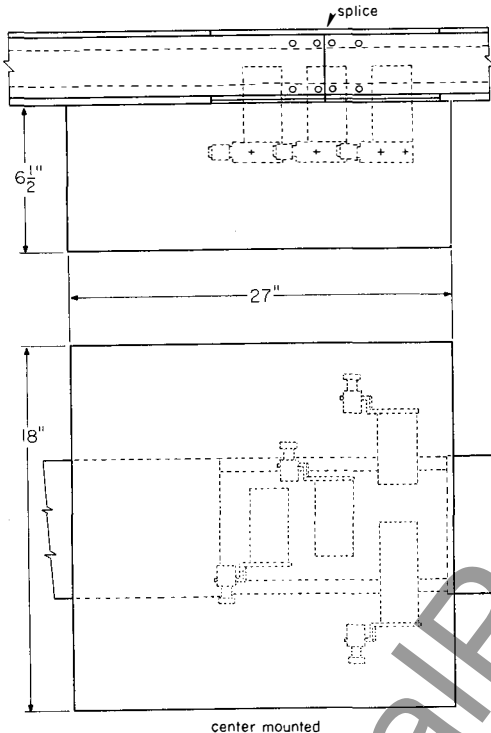

tap box which bolts onto the end of the duct; and the center cable tap box which bolts onto the joint between any two sections of duct.

Solderless lugs are furnished with each cable tap box. The size and number of lugs are listed for each ampere rating in the charts below.

center cable tap box

This cable tap box is bolted on to the front or rear of the duct at the splice between any two sections of duct. The front cover is removable for easy access to the lugs.

lugs

amp rating	per phase and full neutral	half neutral
600	2-600 mcm	2-250 mcm
1000	3-600 mcm	3-250 mcm

end cable tap boxes

End cable tap boxes have a short section of duct attached to them so that they can be bolted onto the end of the duct like any other section. The front cover is removable and the back cover is flush with the rear side of the duct.

The left and right end cable tap boxes are identical except for the short section of duct attached to the boxes. These sections are so constructed that facing the "FRONT" of the duct run with the marking "TOP" upward, the left end cable tap box bolts to the left end of the duct and the right end cable tap box bolts on to the right end of the duct.

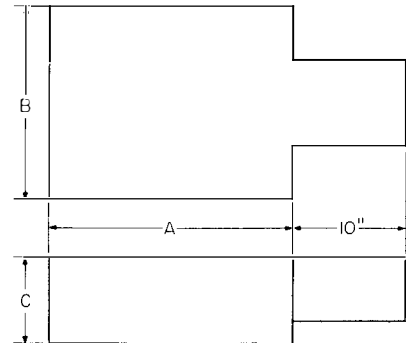

amp rating		dimensions in inches									lugs	
		3Ø3W			3Ø4WHN			3Ø4WFN			per phase and full neutral 600 MCM	half neutral 250 MCM
copper	aluminum	A	B	C	A	B	C	A	B	C		
800	600	21	18	7	21	25	7	21	25	7	3	3
1000	800	21 1/2	18	7	21 1/2	25	7	21 1/2	25	7	3	3
1350	1000	24	24	7	24	25	7	24	25	7	4	4
1600	1350	26 1/2	24	12	26 1/2	27	9	26 1/2	27	9	5	5
2000	1600	29	26	12	29	32	9	29	32	9	6	6
2500	2000	34	26	12	34	32	12	34	32	12	8	8
3000	2500	37	26	18	37	32	12	37	32	12	9	9
4000	3000	45	25	18	45	32	12	45	32	12	8	8
		45	26	18	45	32	12	45	32	12	12	12



PA breaker cubicle

When a breaker with a rating higher than that of an MA is needed, a PA breaker may be used. They are available in continuous ratings of 1000, 1200, 1400, 1600 and 2000 amperes with interrupting ratings up to 150,000 amperes asymmetrical, at 240 volts a-c. Refer to application data 29-160 for complete information on the PA circuit breaker. The PA circuit breaker can be used as a main breaker in a run of duct or as branch feeder protection. These breakers are furnished as bus duct components and are complete with pull box with provisions for incoming and outgoing bus duct.

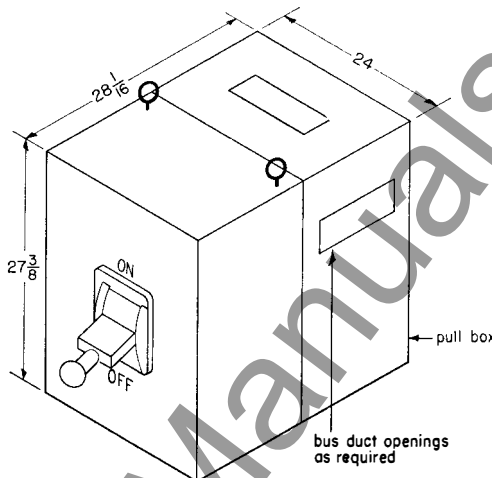

type breaker	dimensions (in inches)		
	A	B	C
PA	26 ³ / ₁₆	46	22 ³ / ₈

pressure type switch^②

Used primarily for service entrance applications, these switches are available in capacities ranging from 1200 to 5000 amperes for 3-wire or 4-wire service, 600 volts maximum. They have bolted high pressure contacts and are used in conjunction with high interrupting capacity fuses to obtain I.C. of 100,000 amperes. The operating mechanism is so arranged that the first turn closes the blades and a continuing motion of the handle tightens the contact bolts at the hinge and jaw, thus actually bolting the blades and contacts together. They may be obtained in either a wall-mounted or a floor-mounted, free-standing enclosure. The switch enclosure is complete with internal bussing, duct entrance and exit stubs and external operating handle. Bus duct line and load connections may be located in the upper and lower sides, top of cubicle, and the upper and lower portions of the rear cover when the cubicle is free-standing. Provisions can be made for built-in current transformers and any other modifications which may be required.

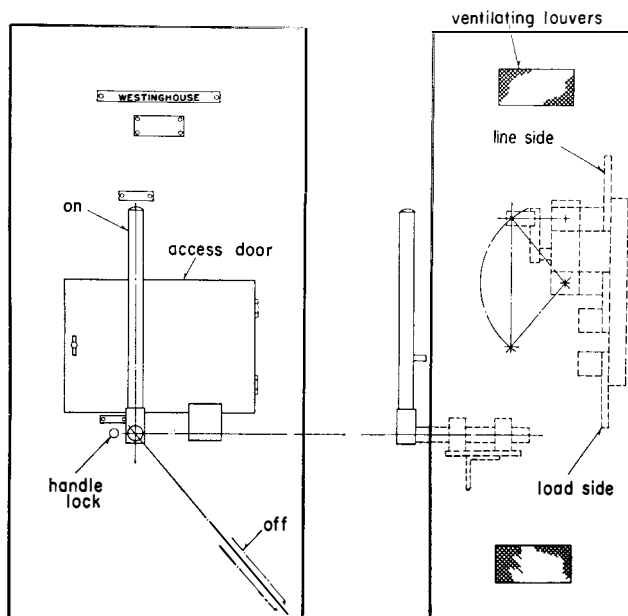

② For dimensions refer to Westinghouse.

plug-in protective devices

A primary advantage of plug-in low impedance bus duct is that power can be taken off close to its utilization point. To accomplish this, easily installed plug-in devices are available which plug-in through the insulators onto the bus bars of the duct. These devices provide overcurrent protection to the conductors and also serve as a disconnecting means.

Two types of overload protective units are available: the AB circuit breaker (type BP), and safety switch

(type TAP). These units are equipped with insulated plug-in stabs which engage the bus bar through plug-in openings in the duct. The stabs are made from cadmium copper alloy. The use of this material makes possible the elimination of reinforcing springs, while maintaining better contact pressure through a wider range of temperatures. All 3-wire units for 3-wire duct only are interchangeable with the 3- and 4-wire plug-in unit on standard plug-in duct.

breaker plug-in ① type BP

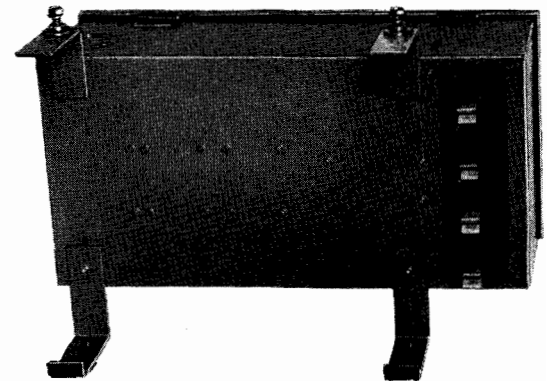
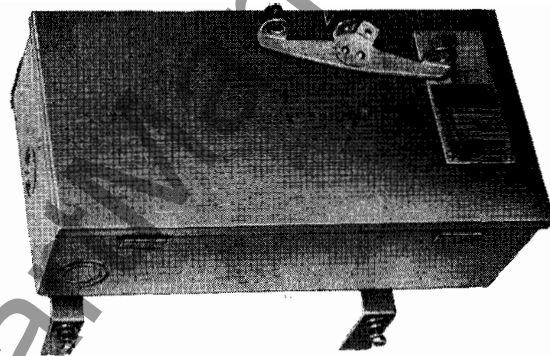
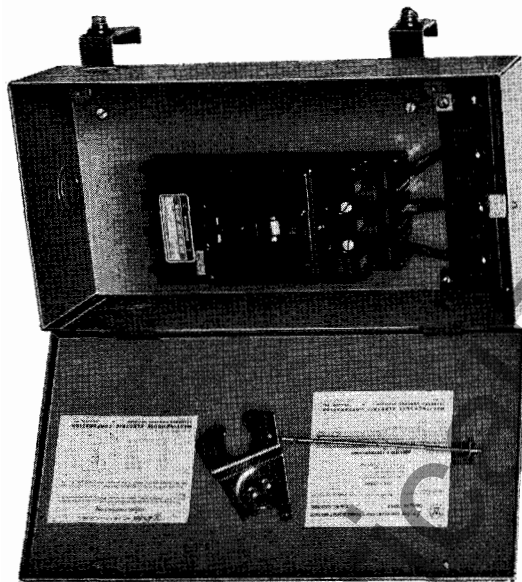

The AB-DE-ION® circuit breakers provide the highest type of automatic branch circuit protection. They incorporate the exclusive Westinghouse "DE-ION" principle of arc quenching and combine thermal and magnetic overload protection on all ratings.

In the event of a dangerous overload or short circuit, the breaker opens the circuit and the handle indicates this by moving to the "TRIPPED" position. The circuit is restored, after the fault is cleared, simply by moving the handle to the "RESET" position and then back to "ON".

The slam-proof cover is locked into place as soon as it is closed and cannot be opened until the operating handle is pulled to the "OPEN COVER" beyond the "OFF" position. The operating handle can be locked in either "OFF" or "ON" position and is constructed

so that the unit can be hookstick, chain, or hand operated. In case of an emergency, a means has been provided for an authorized person to open the cover with the breaker in the "ON" position.

Type E, EH, F, JA, KA and LA breaker plug-ins are furnished with plug-in stabs, and Type MA® breaker units are built with copper extensions that bolt onto the bus bars between any two sections of duct.

The 4-pole solid neutral type E, EH and F plug-ins through 50 ampere rating have lugs designed to accommodate a full-size neutral conductor. However, in all other ratings of type E, EH and F plug-ins and all other circuit breaker plug-ins, when a full-size neutral stab and lug is required, it must be specified in the order write-up. It must also be specified if units are for 3 or 4-wire duct.

① For complete information on breaker types refer to price list 29-120, general catalog.



plug-in low impedance bus duct

circuit breaker plug-in type BP cont'd

E breaker plug-in: 100 amp, 240 volts a-c, non-interchangeable trip. Available in 15, 20, 30, 40, 50, 70, 90 and 100 ampere trip ratings, the Type E plug-in is the standard unit for 240 volt, 2 and 3 pole, and 3-phase, 4-wire systems up to 100 amperes. Connections between the plug-in stabs and the line side of the breaker are made with heavy stranded wire.

EH breaker plug-in: 100 amp, 480 volts a-c, non-interchangeable trip. Same as E except single pole rating is 277 volts a-c with 10,000 amperes interrupting capacity, and 125 volts d-c with 5000 amperes interrupting capacity. Two and three pole 480 volts a-c, 250 volts d-c with 10,000 amperes interrupting capacity.

F breaker plug-in: 100 amp, 600 volts a-c, non-interchangeable trip. Type F breaker plug-in is used up to and including 100 amperes, 600 volts, and is available with 15, 20, 30, 40, 50, 70, 90 and 100 ampere trip ratings. Connections between the line side of the breaker and the plug-in stabs are made with heavy stranded wire.

JA breaker plug-in: 225 amp, 600 volts a-c, non-interchangeable trip. When a larger breaker is needed the Type JA breaker plug-in is used to and including 225 amperes, 600 volts. It is available with 70, 90, 100, 125, 150, 200 and 225 ampere trip ratings.

KA breaker plug-in: 225 amp, 600 volts a-c interchangeable trip. Wherever a larger breaker with an interchangeable trip is needed, the KA breaker plug-in is used up to and including 225 ampere, 600 volts. It is available with 70, 90, 100, 125, 150, 175, 200 and 225 ampere trip ratings.

LA breaker plug-in: 400 amp, 600 volts a-c interchangeable trip. These units provide a maximum of 400 ampere, 600 volt protection in minimum space. The LA breaker plug-in has an interchangeable trip with ratings of 125, 150, 175, 200, 225, 250, 300, 350 and 400 amperes.

MA[ⓐ] breaker bolt-on: 800 amp, 600 volts a-c, interchangeable trip. Trip ratings available are 125, 150, 175, 200, 225, 250, 275, 300, 325, 350, 400, 450, 500, 550, 600, 700 and 800 amperes.

ⓂARK 75[Ⓜ] Available in HE, HK, HKL and HLM frame sizes. Ideally suited for network systems where unusually high fault currents are available. (See price list 29-120 for additional information).

ⓂTRI-PAC[Ⓜ]: The TRI-PAC breaker provides triple protection in a single compact device; thermal, magnetic and current limiting. Available in 100, 225, 400 and 600 ampere frame sizes.

E, EH, FA, JA, KA and LA breaker enclosure

MA breaker enclosure

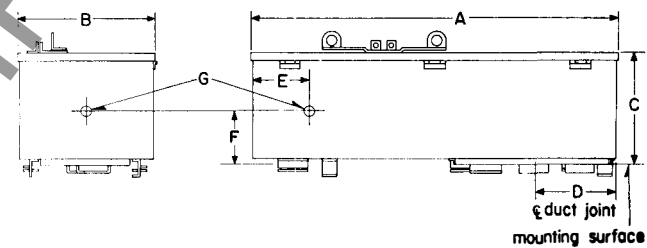
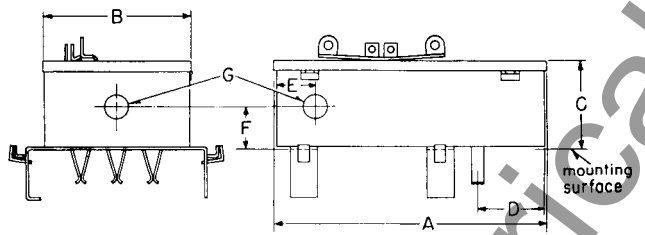

circuit breaker [Ⓜ]	3 wire						net wt., lbs		
	A	B	C	D	E	F	G	2 pole	3 pole
E	16 ¹ / ₈	8 ¹ / ₁₆	4 ⁹ / ₁₆	3 ¹ / ₁₆	1 ⁵ / ₁₆	1 ³ / ₈	3 ⁴ -1-1 ¹ / ₄	13	15
EH	16 ¹ / ₈	8 ¹ / ₁₆	4 ⁹ / ₁₆	3 ¹ / ₁₆	1 ⁵ / ₁₆	1 ³ / ₈	3 ⁴ -1-1 ¹ / ₄	15	16
F	18 ¹ / ₈	8 ¹ / ₁₆	5 ⁹ / ₁₆	3 ¹ / ₁₆	1 ⁵ / ₁₆	1 ³ / ₈	3 ⁴ -1-1 ¹ / ₄	18	20
JA	20 ⁷ / ₁₆	9 ¹ / ₄	5 ¹ / ₁₆	3 ³ / ₁₆	2 ⁹ / ₁₆	2 ³ / ₈	2-2 ¹ / ₂ -3	32	34
KA	20 ⁷ / ₁₆	9 ¹ / ₄	5 ¹ / ₁₆	3 ³ / ₁₆	2 ⁹ / ₁₆	2 ³ / ₈	2-2 ¹ / ₂ -3	32	34
LA	24 ¹ / ₁₆	10 ¹ / ₂	6 ⁷ / ₈	3 ³ / ₁₆	4 ³ / ₈	2 ³ / ₈	2-2 ¹ / ₂ -3	50	53
MA [ⓐ]	33 ³ / ₁₆	12 ¹ / ₂	12 ¹ / ₈	7 ¹ / ₁₆	111	118

circuit breaker [Ⓜ]	4 wire half and full neutral							net wt., lbs 3 [∅] 4W
	A	B	C	D	E	F	G	
E	14 ³ / ₈	9 ³ / ₁₆	4 ⁹ / ₁₆	1 ⁵ / ₁₆	2	1 ³ / ₈	1-1 ¹ / ₄ -1 ¹ / ₂	16
EH	14 ³ / ₈	9 ³ / ₁₆	4 ⁹ / ₁₆	1 ⁵ / ₁₆	2	1 ³ / ₈	1-1 ¹ / ₄ -1 ¹ / ₂	17
F	17 ¹ / ₈	9 ³ / ₁₆	5 ⁹ / ₁₆	1 ⁵ / ₁₆	1 ⁵ / ₁₆	1 ³ / ₈	1-1 ¹ / ₄ -1 ¹ / ₂	21
JA	18 ⁷ / ₁₆	11 ¹ / ₄	5 ¹ / ₁₆	1 ³ / ₈	2 ⁹ / ₁₆	2 ³ / ₈	2-2 ¹ / ₂ -3	35
KA	18 ⁷ / ₁₆	11 ¹ / ₄	5 ¹ / ₁₆	1 ³ / ₈	2 ⁹ / ₁₆	2 ³ / ₈	2-2 ¹ / ₂ -3	35
LA	22 ¹ / ₁₆	11 ³ / ₈	6 ⁷ / ₈	1 ³ / ₈	4 ⁷ / ₁₆	2 ³ / ₈	2-2 ¹ / ₂ -3	54
MA [ⓐ]	35 ¹ / ₁₆	12 ¹ / ₂	12 ¹ / ₈	7 ¹ / ₁₆	119

Ⓜ Changed or added since previous issue.
 Ⓜ Above 225 amperes bolts on at joint.
 Ⓜ Bolts on at joint.

Refer to Westinghouse
Refer to Westinghouse

plug-in protective devices

safety switch plug-in^① type TAP

For use on motor circuits and heavy-duty industrial circuits, type TAP fusible plug-in is available in 30, 60, 100, 200, 400 and 600 ampere ratings in 2-pole, 3-pole, and 3-phase, 4-wire types for 240 and 600 volt circuits.

The 30, 60 and 100 ampere units use the visible blade de-ion switch. The 200 ampere unit uses the Visi-flex switch. The 400 and 600 ampere units use a

non-automatic circuit breaker. These units have a front-operated device similar to the circuit breaker plug-in and can be hookstick, chain or hand operated. Cover is interlocked to prevent opening while the switch is "ON." A second interlock is provided to prevent accidental closing of switch when cover is open. Four-pole solid neutral units in the 60 and 30 ampere ratings have proper lugs to accommodate a full-size neutral conductor. **However, in all other ratings, a full-size neutral stab and lug must be specified in the order write-up, if needed.**

front operated
30, 60, 100 and
200 amp. type
TAP safety
switch plug-in

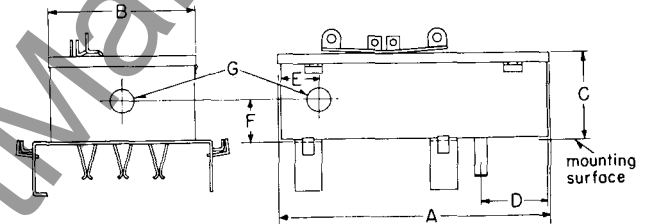
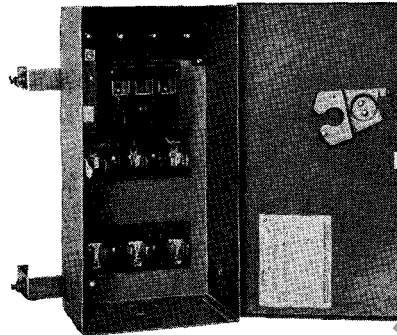

amp rating	voltage	poles	horsepower rating		dimensions (inches)							net wt., lbs
			N.E.C. stand.	time delay	A	B	C	D ^②	E	F	G	
30	240	2	1½	3	18 7/8	8 1/16	5 3/8	3 9/16	1 9/16	1 3/8	3/4-1-1/4-1-1/2	15
	240	3	3	7 1/2	18 7/8	8 1/16	5 3/8	3 9/16	1 9/16	1 3/8	3/4-1-1/4-1-1/2	16
	240	3Ø4W	3	7 1/2	17 1/4	9 3/16	5 3/8	1 7/8	1 1/2	1 3/4	3/4-1-1/4-1-1/2	16
	600	2	3	10	18 7/8	8 1/16	5 3/8	3 9/16	1 9/16	1 3/8	3/4-1-1/4-1-1/2	15
	600	3	7 1/2	20	18 7/8	8 1/16	5 3/8	3 9/16	1 9/16	1 3/8	3/4-1-1/4-1-1/2	16
	277/480	3Ø4W	5	15	17 1/4	9 3/16	5 3/8	1 7/8	1 1/2	1 3/4	3/4-1-1/4-1-1/2	16
60	240	2	3	10	18 7/8	8 1/16	5 3/8	3 9/16	1 9/16	1 3/8	3/4-1-1/4-1-1/2	15
	240	3	7 1/2	15	18 7/8	8 1/16	5 3/8	3 9/16	1 9/16	1 3/8	3/4-1-1/4-1-1/2	16
	240	3Ø4W	7 1/2	15	17 1/4	9 3/16	5 3/8	1 7/8	1 1/2	1 3/4	3/4-1-1/4-1-1/2	16
	600	2	10	25	18 7/8	8 1/16	5 3/8	3 13/16	1 9/16	1 3/8	3/4-1-1/4-1-1/2	15
	600	3	15	50	18 7/8	8 1/16	5 3/8	3 9/16	1 9/16	1 3/8	3/4-1-1/4-1-1/2	16
	277/480	3Ø4W	15	30	17 1/4	9 3/16	5 3/8	1 7/8	1 1/2	1 3/4	3/4-1-1/4-1-1/2	16
100	240	2	7 1/2	15	22 3/4	8 1/16	5 1 1/16	3 1 1/16	2 3/4	1 7/8	3/4-1-1/4	22
	240	3	15	30	22 3/4	8 1/16	5 1 1/16	3 1 1/16	2 3/4	1 7/8	3/4-1-1/4	22
	240	3Ø4W	15	30	21 7/8	10 5/8	5 1 1/16	2 13/16	2 3/4	1 7/8	3/4-1-1/4	23
	600	2	15	40	22 3/4	8 1/16	5 1 1/16	3 1 1/16	2 3/4	1 7/8	3/4-1-1/4	23
	600	3	30	50	22 3/4	8 1/16	5 1 1/16	3 1 1/16	2 3/4	1 7/8	3/4-1-1/4	23
	277/480	3Ø4W	25	50	21 7/8	10 5/8	5 1 1/16	2 13/16	2 3/4	1 7/8	3/4-1-1/4	25
200	240	2	15	...	19 7/8	15 1/8	8 3/16	3 1 1/16	2 9/16	2 3/8	2-2 1/2-3	56
	240	3	25	50	19 7/8	15 1/8	8 3/16	3 1 1/16	2 9/16	2 3/8	2-2 1/2-3	57
	240	3Ø4W	25	50	19 3/8	15 5/8	8 1/16	1 1 1/16	2 9/16	2 3/8	2-2 1/2-3	58
	600	2	30	50	19 7/8	15 5/8	8 3/16	3 1 1/16	2 9/16	2 3/8	2-2 1/2-3	56
	600	3	50	...	19 7/8	15 5/8	8 3/16	3 1 1/16	2 9/16	2 3/8	2-2 1/2-3	57
	277/480	3Ø4W	50	...	19 3/8	15 5/8	8 1/16	1 1 1/16	2 9/16	2 3/8	2-2 1/2-3	58
④400	240	2	19 1 5/16	16 1/4	13 9/16	6 1/32	16 3/4	9 1/8	2-2 1/2-3	79
	240	3	19 1 5/16	16 1/4	13 9/16	6 1/32	16 3/4	9 1/8	2-2 1/2-3	80
	240	3Ø4W	19 1 5/16	16 1/4	13 9/16	6 1/32	16 3/4	9 1/8	2-2 1/2-3	81
	600	2	19 1 5/16	16 1/4	13 9/16	6 1/32	16 3/4	9 1/8	2-2 1/2-3	79
	600	3	19 1 5/16	16 1/4	13 9/16	6 1/32	16 3/4	9 1/8	2-2 1/2-3	80
	277/480	3Ø4W	19 1 5/16	16 1/4	13 9/16	6 1/32	16 3/4	9 1/8	2-2 1/2-3	81
600 ①	240	3	33 3/8	15 1/2	15 3/4	7 1 1/16	157
	240	3Ø4W	33 3/8	15 1/2	15 3/4	7 1 1/16	158
	600	3	33 3/8	15 1/2	15 3/4	7 1 1/16	157
	277/480	3Ø4W	33 3/8	15 1/4	15 3/4	7 1 1/16	158

① Changed or added since previous issue.
② Line and load same end.



combination Life-Line® starter plug-ins

For motor circuits the ultimate in motor overload and branch conductor protection is furnished by combination Life-Line starter plug-ins. The unit consists of a Linestarter for motor overload protection and a circuit breaker or a De-ion® Switch with fuses for protection of the conductors. Additional safety for operating personnel can be obtained by using a step-down control transformer to provide a low-voltage

control circuit. These units are available for motors up to 100 horsepower, 440 volts, which use a size 4 starter and type JA breaker. A remote control push-button can be located at any convenient place. *When ordering a combination plug-in Life-Line starter, include all information necessary for any other combination starter.*

ground detector and neutralizer plug-in

In rare cases, bus bars in a bus duct system pick up static electricity. In order to discharge this potential, a neutralizer plug is available which also serves as a ground detector. The unit has an 18,000 ohm resistor connected between the bus bars and the ground. Static electricity is discharged through this resistor. A neon lamp is placed in series with the bus bar and part of the resistor and burns continuously. If there is a ground anywhere on the system which is of lower resistance than the path through the lamp, the lamp will go out, indicating that there is a short in the system. *When ordering specify system voltage—240, 480 or 575. For 3 ∅ 3 wire systems only.*

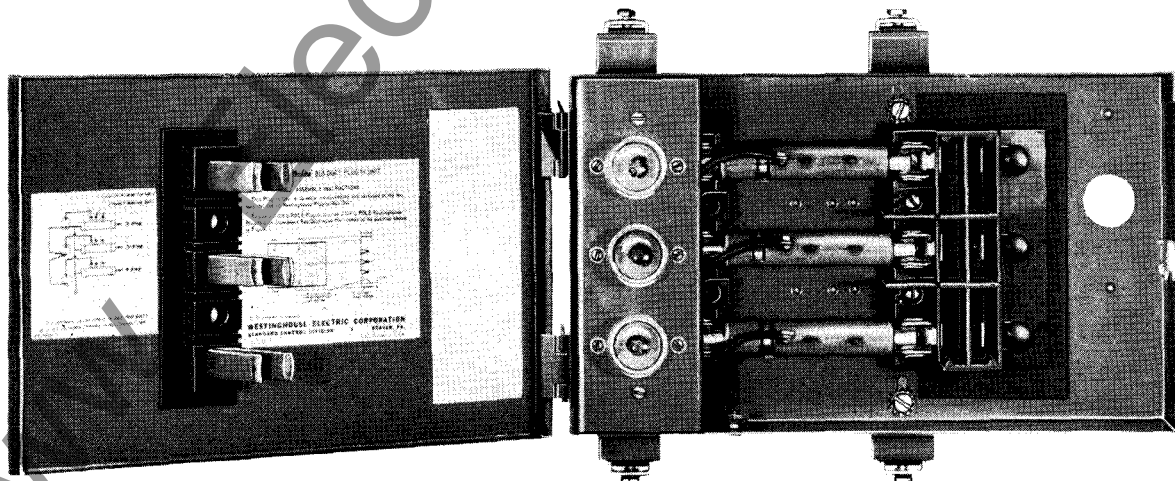
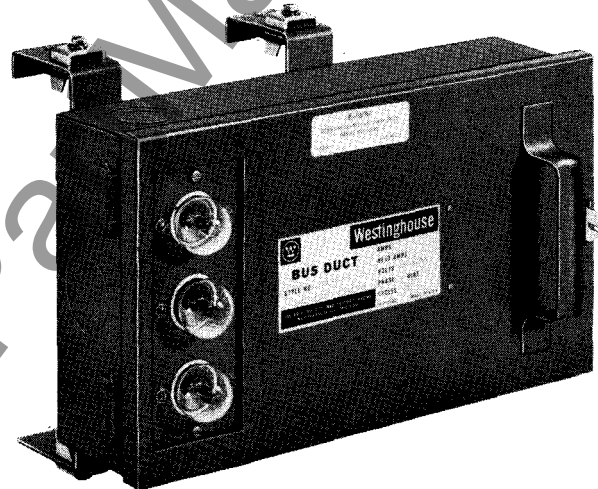

hangers for plug-in low impedance duct

cantilever edgewise mounted duct

One cantilever hanger is supplied for every 10 feet of duct. This hanger can be used on all 2 bar per phase plug-in low impedance bus duct except 5 inch, 6 inch and 7 inch copper bus bar ratings. Drop rods and hardware are supplied by contractor.

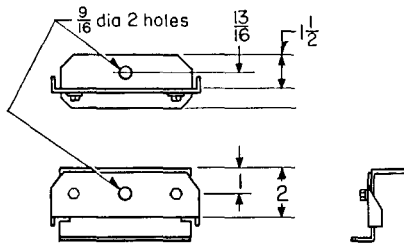

"C" clamp flatwise or edgewise mounted duct

One "C" clamp hanger is supplied with every 10 feet of bus duct when required. This hanger can be used on 2 bar per phase 1 inch through 4 inch copper bus bar and 1 inch through 7 inch aluminum bus bar, three wire and four wire half neutral bus duct only.

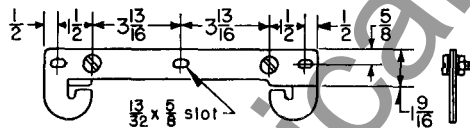

trapeze type flatwise or edgewise mounted duct

Used to hang duct in a flatwise position or in edge-wise position when proper bar size is applied. General dimensions are shown below:

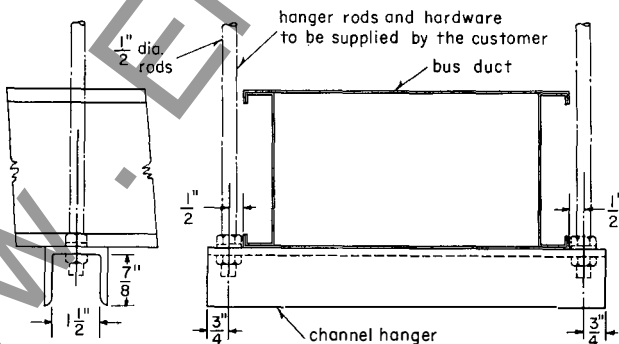

hanger for vertical mounting

This unique hanger equalizes the weight of vertically mounted duct among all supports. A vertical hanger should be used for every ten feet of duct. However, if floors are not over 14 feet apart one hanger per floor may be used. Although the tables and drawings apply to plug-in low impedance duct, this hanger may be used with plug-in and low impedance duct.

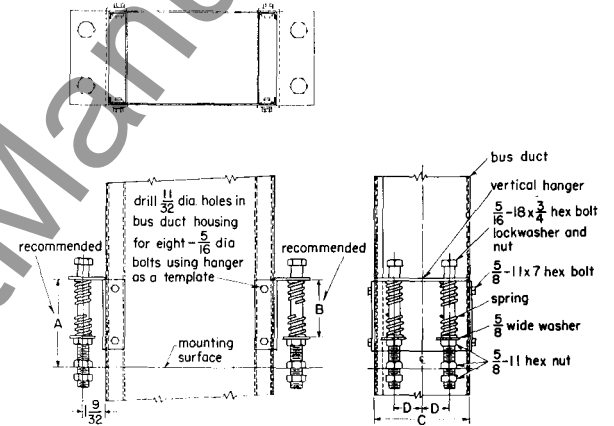

deflection diagram

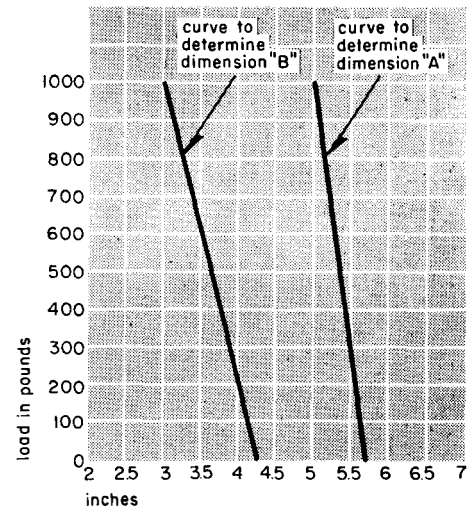

dimensions (inches)

C	D	C	D
3/8	15/16	6/8	23/32
3/8	31/32	7/8	219/32
4/8	13/32	8/8	33/32
4/8	111/32	9/8	319/32
5/8	119/32		



engineering and test data

dimensions and weights

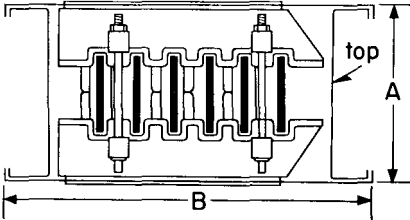

ventilated duct

amp rating	dimension B (inches) and weights						bar size	A dim. inches
	3 wire	lb ft.	4 wire 1/2 neut.	lb ft.	4 wire F/N	lb ft.		
copper								
800	9 5/8 ↓	11	10 5/8 ↓	13	11 5/8 ↓	14	2-1/2 x 1	3 3/8
1000		15		17		19	2-1/4 x 1 1/2	3 7/8
*1350		19		21		23	2-1/4 x 2	4 3/8
*1600		22		25		28	2-1/4 x 2 1/2	4 7/8
*2000		25		28		30	2-1/4 x 3	5 3/8
*2500		32		37		41	2-1/4 x 4	6 3/8
*3000		40		46		52	2-1/4 x 5	7 3/8
*4000		54		63		69	2-1/4 x 7	9 3/8

aluminum								
600	9 5/8 ↓	7	10 5/8 ↓	8	11 5/8 ↓	9	2-1/4 x 1	3 3/8
800		9		10		11	2-1/4 x 1 1/2	3 7/8
*1000		11		12		13	2-1/4 x 2	4 3/8
*1350		12		13		14	2-1/2 x 2 1/2	4 7/8
*1600		13		14		15	2-1/4 x 3	5 3/8
*2000		15		17		19	2-1/4 x 4	6 3/8
*2500		21		25		27	2-1/4 x 6	8 3/8
*3000		25		29		31	2-1/4 x 7	9 3/8

① Flatwise mounting only

enclosed duct

amp rating	dimension B (inches) and weights						bar size	A dim. inches
	3 wire	lb ft.	4 wire 1/2 neut.	lb ft.	4 wire F/N	lb ft.		
copper								
600	9 5/8 ↓	13	10 5/8 ↓	15	11 5/8 ↓	16	2-1/4 x 1	3 3/8
800		16		18		20	2-1/4 x 1 1/2	3 7/8
1000		20		22		24	2-1/4 x 2	4 3/8
1350		34		39		42	2-1/4 x 4	6 3/8
*1600		42		48		54	2-1/4 x 5	7 3/8
*2000		49		58		64	2-1/4 x 6	8 3/8

aluminum								
600	9 5/8 ↓	10	10 5/8 ↓	11	11 5/8 ↓	12	2-1/4 x 1 1/2	3 7/8
800		13		14		15	2-1/4 x 2 1/2	4 7/8
1000		17		19		21	2-1/4 x 4	6 3/8
1350		23		27		29	2-1/4 x 6	8 3/8
1600		27		31		33	2-1/4 x 7	9 3/8

* Flatwise mounting only

engineering and test data

line to line voltage drop • per 100 feet distributed loading

ampere rating	percent power factor											
	0	10	20	30	40	50	60	70	80	90	95	100

copper

800	1.36	1.50	1.62	1.73	1.82	1.90	1.95	1.97	1.96	1.88	1.78	1.43
1000	1.30	1.40	1.50	1.58	1.64	1.69	1.71	1.71	1.68	1.58	1.48	1.13
1350	1.48	1.59	1.67	1.75	1.80	1.83	1.87	1.85	1.79	1.66	1.53	1.13
1600	1.55	1.63	1.72	1.79	1.84	1.87	1.87	1.83	1.76	1.62	1.47	1.04
2000	1.61	1.71	1.80	1.87	1.92	1.96	1.96	1.94	1.87	1.71	1.57	1.13
2500	1.67	1.77	1.86	1.93	1.98	2.01	2.02	1.99	1.91	1.75	1.60	1.14
3000	1.66	1.78	1.87	1.95	2.00	2.04	2.06	2.04	1.97	1.82	1.68	1.26
4000	1.51	1.60	1.67	1.73	1.77	1.78	1.78	1.75	1.67	1.51	1.37	0.95

aluminum

600	1.02	1.18	1.33	1.47	1.59	1.71	1.81	1.88	1.93	1.92	1.88	1.64
800	1.19	1.34	1.48	1.60	1.72	1.81	1.88	1.94	1.95	1.91	1.85	1.55
1000	1.10	1.23	1.35	1.45	1.55	1.64	1.71	1.75	1.75	1.71	1.64	1.37
1350	1.31	1.45	1.59	1.69	1.80	1.88	1.94	1.99	1.97	1.92	1.84	1.50
1600	1.39	1.52	1.65	1.76	1.86	1.94	1.98	2.02	2.01	1.93	1.82	1.47
2000	1.56	1.70	1.80	1.91	1.97	2.04	2.08	1.10	2.04	1.94	1.80	1.40
2500	1.25	1.30	1.50	1.61	1.70	1.75	1.83	1.86	1.86	1.79	1.71	1.39
3000	1.25	1.36	1.46	1.55	1.62	1.68	1.71	1.73	1.70	1.62	1.52	1.20

For line to neutral values, multiply the above figures by .577.

typical specifications for plug-in low impedance bus duct

general

The bus duct shall be of the ventilated type with two { aluminum } conductors per phase supported in a sheet steel housing. The complete installation shall be coordinated throughout, rigid in construction, of uniform size and neat and symmetrical in appearance. As many sections as possible shall be ten foot lengths. Special sections and/or fittings shall be provided only where necessary to suit the installation. Access openings to the bolted joints of conductors shall be provided on two opposite sides of the duct. Conductor joints shall be made in such a manner that no increase of enclosure size is required at the splice between adjoining sections. One hanger shall be provided for every 10'0" of horizontally mounted duct. The duct shall be suitable for supporting at 10'0" intervals. For vertically mounted duct, one adjustable vertical hanger shall be provided per 12'0" of riser or per span between floors. The bus shall be listed by Underwriter's Laboratories including mounting in either the horizontal or vertical position. The bus duct shall be as manufactured by Westinghouse or approved equal.

enclosure

The duct housing which shall be made from 16-gauge steel, according to Underwriters' standards, shall be of the 4-channel interlocking type of construction. It shall be bonderized both inside and outside and given one coat of ASA 49 medium light gray, baked-on enamel. At least two sides of the ventilated duct shall have perforations stamped out. Two removable access covers shall be provided at each splice to insure ease of inspection of bus bar joints and to facilitate the bolting on of current take-off devices. Two splice plates shall be provided at each splice to insure a strong, positive, mechanical connection being made between the housing of adjoining sections. Spring retained, sliding plate type outlet covers shall be provided, to cover each plug-in opening when not in use.



typical specifications for plug-in low impedance bus duct

conductors

The conductors of aluminum shall be fabricated from high strength, 55% minimum conductivity extruded aluminum bus bars. Bars shall be of the rectangular type with full rounded edges. All aluminum bus bars shall be plated electrolytically their entire length with silver using the 13 step plating process.

The conductors of copper shall be fabricated of the best grade, 98% conductivity pure copper bus bars. Bus bars shall be of the rectangular type with full rounded edges. All copper bus bars shall be silver plated their entire length.

Except for the portion required for the lap joint, the bus bars shall be completely insulated with polyvinyl chloride tubing of not less than .020 total thickness or other approved insulating sheath. A tie bar shall be bolted to one end of the bus bars complete with threaded steel inserts and captive hardware. The other end of the bus shall be slotted for ease in making the joint. The joint hardware shall be heat-treated zinc chromate plated steel with a tensile strength of 100,000 pounds per square inch.

Bus bar joints shall be so arranged that no additional insulation need be applied.

bus bar assembly

The bus bars shall be firmly supported on 1-inch centers for plug-in fittings and 3/4-inch centers on non plug-in fittings in such a manner that their flat sides are adjacent. In order to reduce reactance, bars of opposite polarity shall be interlaced to provide a repeating phase sequence. Tie-bars shall be provided with each section in order to balance the load of each phase bar. Four-wire systems shall have all neutral conductors assembled entirely to one side of the phase bar assembly. The bus bar assembly shall withstand short circuit stresses in accordance with NEMA short circuit ratings for busways. Supports shall be of high strength polyester glass located on both sides of the housing and spaced on no greater than 20-inch centers. Supports shall be of the type through which it is possible to insert the stabs of a plug-in device in order to fully isolate stabs as well as afford extra protection in the event of stresses due to a fault.

operating characteristics

The bus duct shall be so designed and tested that, at rating, no part shall exceed 55°C rise. The bus duct shall withstand for one minute without breakdown the application of 2200 volts of 60 cycle alternating potential between conductors and between conductors and the enclosure.