

Cutler-Hammer Beaver, PA

Automatic Transfer Switch

Type **ATSRM** Wiring Diagrams

Cutler-Hammer
Power Distribution Components Division
One Tuscarawas Road
Beaver, PA 15009

Copyright 1995 by Eaton/Cutler-Hammer Inc.
All Rights Reserved

Version 1.2 10-9-92

Cutler-Hammer Automatic Transfer Switch Wiring Diagrams

Directions for Use

The drawing package can be used as a point to point wiring diagram for maintenance and diagnostic purposes for Solid State Logic SPB Transfer Switches, all voltages.

This document contains the following wiring information:

Page 1

Basic Solid State Intelligence Panel Wiring exclusive of added option functions

Page 2

Power Switching Panel basic wiring exclusive of added option functions.

Pages 3 - 18

Wiring for optional functions

Page 19

Legend Sheet describing symbols used throughout this document

Note: Unnumbered sheets may be added to this document on specific occasions to illustrate custom options additions per order instructions.

All transfer switch units will be standardly wired as indicated by Pages 1, and 2. The Intelligence Panel and Power Panel are interconnected via keyed plug/socket connectors (P1-S1/P2-S2). Your specific unit may be equipped with certain optional functions as noted which require additional wiring as shown on pages 3 - 18.

Wiring for optionally added functions will typically interface with the basic unit wiring (Pages 1-2) which should be used as the base reference.

Note: **BOLD** lines on option wiring indicate components and wiring added to the basic wiring diagram to accomplish that specific option function.

Cutler-Hammer Automatic Transfer Switch

Standard Features

Test Pushbutton

Simulates a power failure in the logic. Will cause the Generator to start, and load to transfer to the Emergency Source.

Undervoltage Protection on NORMAL (All phases)

Monitors the voltage on the NORMAL Source for an undervoltage condition. Should the voltage drop below a preset Dropout, the generator is started and transfer to the EMERGENCY Source takes place.

Engine Start Contact

Contact that provides a closure to Engine Controller when the NORMAL Source fails.

Logic Disconnect

Plugs provided to disconnect the logic circuitry for maintenance purposes.

Auxiliary Contacts

Auxiliary contacts integral to the switching devices rated at 120 VAC, 10 amps. These may be applied for customer use, and may be applied to certain customer specified options.

Fully Rated Neutral

A fully rated solid neutral is supplied on all two and three pole switches. All four pole switches are supplied with switched neutral contacts of identical construction and rating as the power poles.

SPB ATS INTELLIGENCE PANEL

NOTE A

NOTE A:

TRANSFORMERS NT3, NT4 AND WIRES 103, 109 USED FOR 3 PHASE NORMAL SENSING

TRANSFORMERS ET3, ET4 AND WIRES 114, 116 USED FOR 3 PHASE EMERGENCY SENSING (OPTION 5F AND/OR 5G)

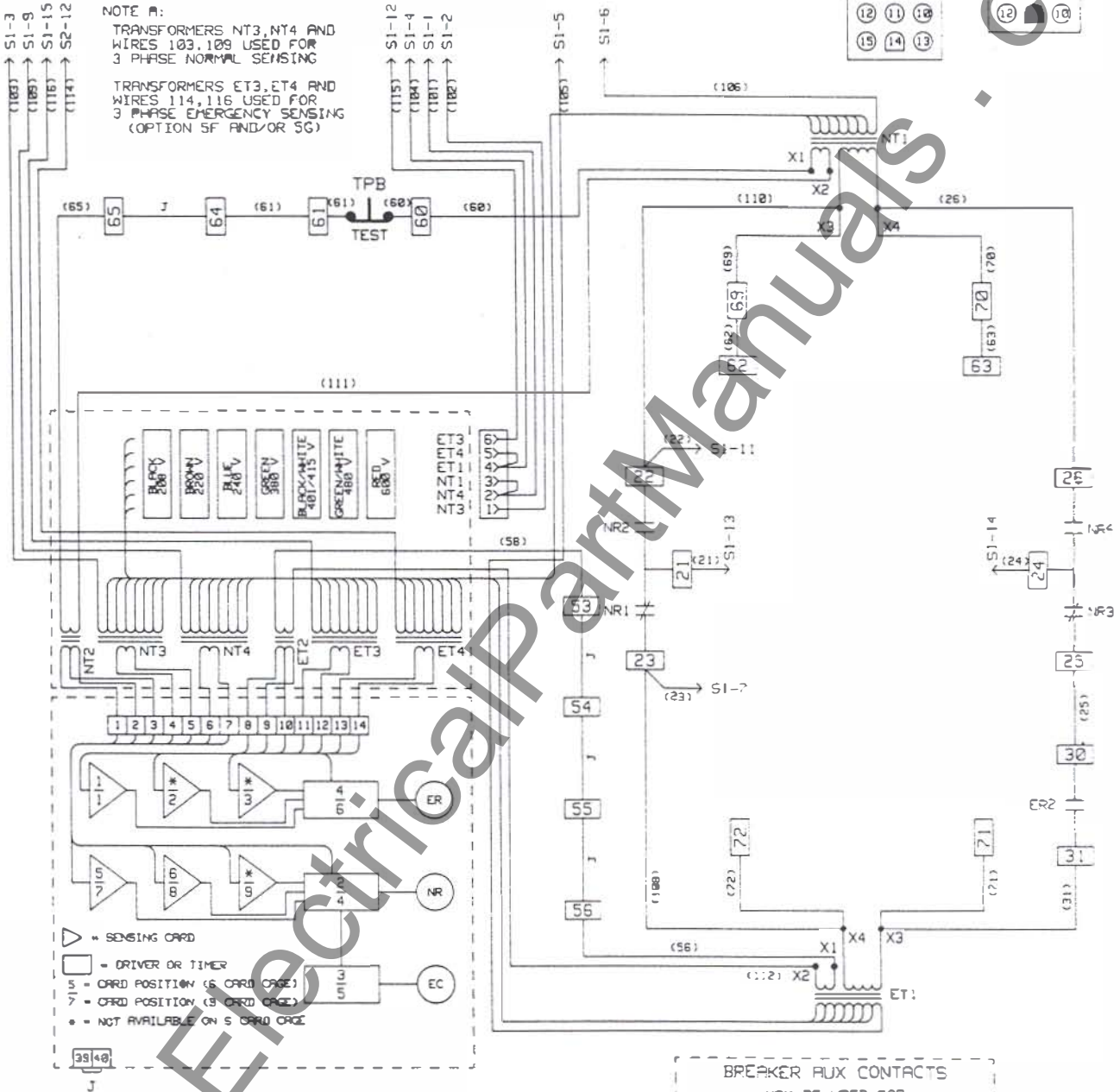

- ▷ = SENSING CARD
- = DRIVER OR TIMER
- 5/ = CARD POSITION (5 CARD CRG)
- 7/ = CARD POSITION (3 CARD CRG)
- = NOT AVAILABLE ON 5 CARD CRG

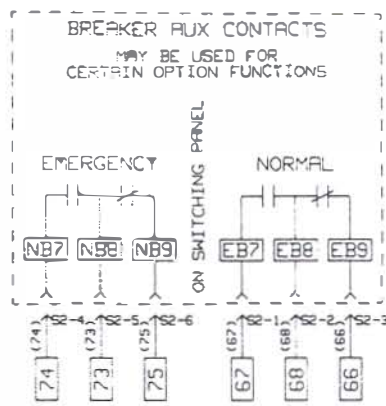
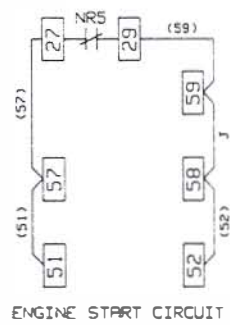
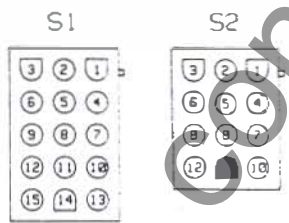

www.ElectricalPartManuals.com

SPB POWER SWITCHING PANEL (FIXED MOUNT)

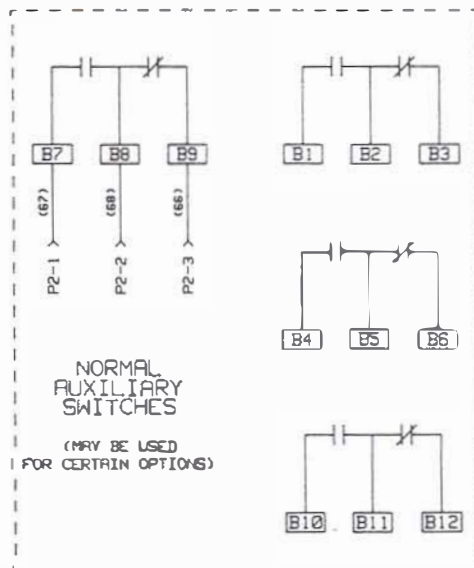
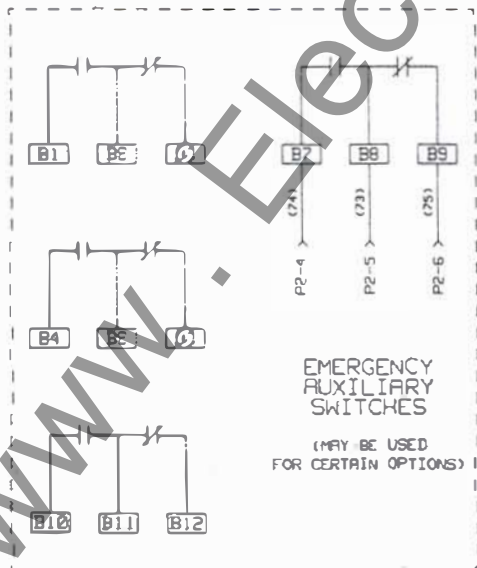
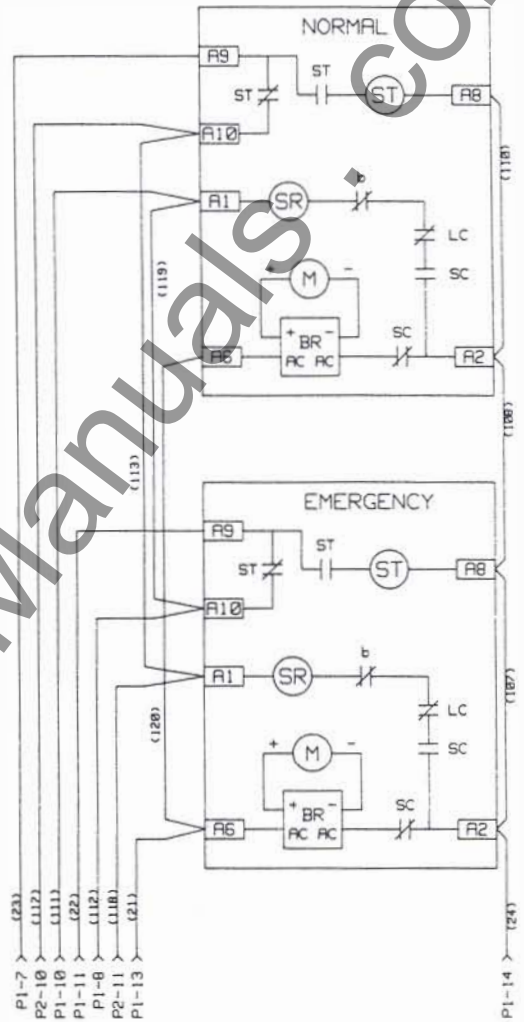
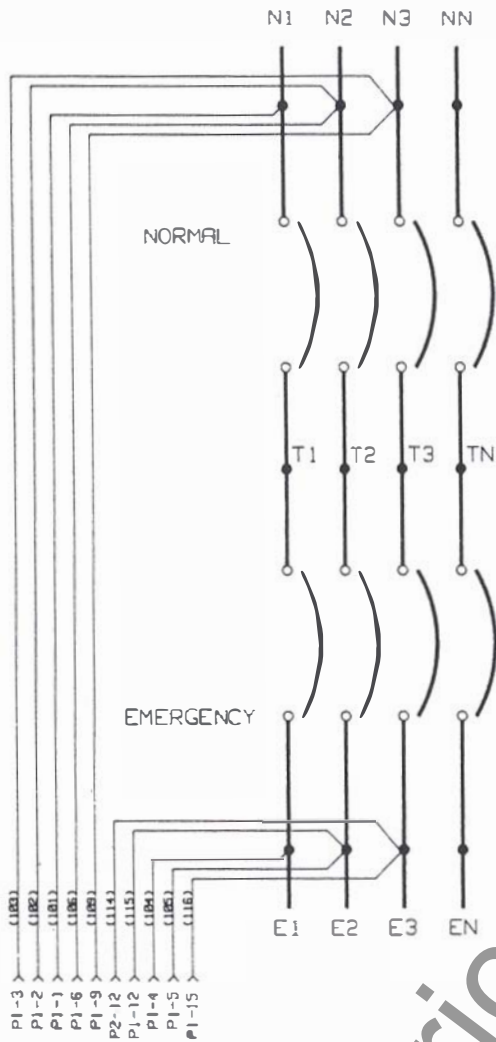

6 POSITION CARD CAGE

NORMAL		ENG	EMERGENCY		
1	2	3	4	5	6
UNDERVOLTAGE STD	DRIVER (OPTION 3)	BLANK (OPTION 4)	DRIVER (OPTION 1)	BLANK (OPTION 5)	BLANK (OPTION 5)

9 POSITION CARD CAGE

NORMAL				ENG	EMERGENCY			
1	2	3	4	5	6	7	8	9
UNDERVOLTAGE STD	BLANK (OPTION 26)	BLANK (OPTION 26)	DRIVER (OPTION 3)	BLANK (OPTION 4)	DRIVER (OPTION 1)	BLANK (OPTION 5)	BLANK (OPTION 5)	BLANK (OPTION 5)

OPTION 1 - TIME DELAY NORMAL TO EMERGENCY (TDNE)

6 POSITION CARD CAGE
REPLACE DRIVER CARD IN POSITION 4 WITH TIMER CARD

9 POSITION CARD CAGE
REPLACE DRIVER CARD IN POSITION 6 WITH TIMER CARD

OPTION 3 - TIME DELAY EMERGENCY TO NORMAL (TDEN)

6 POSITION CARD CAGE
REPLACE DRIVER CARD IN POSITION 2 WITH TIMER CARD

9 POSITION CARD CAGE
REPLACE DRIVER CARD IN POSITION 4 WITH TIMER CARD

OPTION 4 - TIME DELAY ENGINE COOLOFF (TDEC)

6 POSITION CARD CAGE
REPLACE BLANK CARD IN POSITION 3 WITH TIMER CARD
ADD EC RELAY TO MOTHERBOARD

9 POSITION CARD CAGE
REPLACE BLANK CARD IN POSITION 5 WITH TIMER CARD
ADD EC RELAY TO MOTHERBOARD

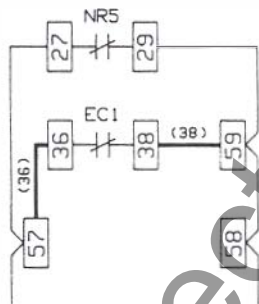

OPTION 4 ONLY

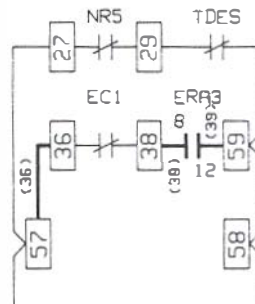

OPTION 4 WITH 2 **
** REQUIRES OPTION 14D

OPTION 5 - EMERGENCY SENSING (UV,OV,UF,OF)

6 POSITION CARD CAGE
REPLACE BLANK CARD IN POSITION 5 OR 6 WITH APPROPRIATE SENSING CARD

9 POSITION CARD CAGE
REPLACE BLANK CARD IN POSITION 7, 8 OR 9 WITH APPROPRIATE SENSING CARD

OPTION 26 - NORMAL SENSING (OV,UF,OF)

6 POSITION CARD CAGE
NOT AVAILABLE

9 POSITION CARD CAGE
REPLACE BLANK CARD IN POSITION 2 OR 3 WITH APPROPRIATE SENSING CARD

* UNDERVOLTAGE SENSING ON NORMAL IS STANDARD

OPTION 2 - TIME DELAY ENGINE START (TDES)

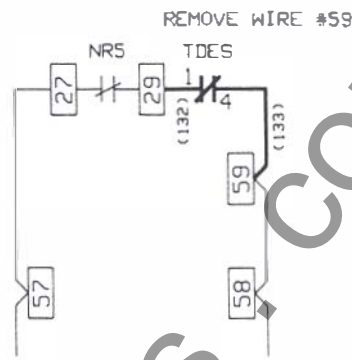
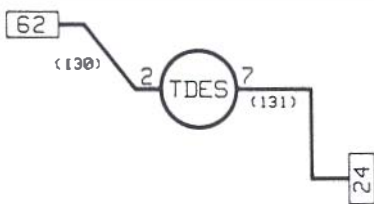

OPTION 6D - TEST SELECTOR (TSS)



OPTION 6H - FOUR POSITION SELECTOR SWITCH (FPSS)

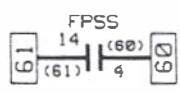

REPLACES STANDARD TEST SELECTOR SWITCH

FPSS	J9 10T	J11 12T	J4 14T	J15 16T	J17 18T
TEST					
AUTO					
OFF					
ENG. RUN					

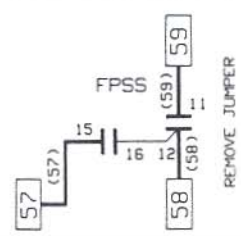
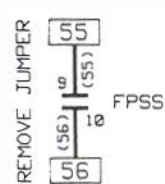
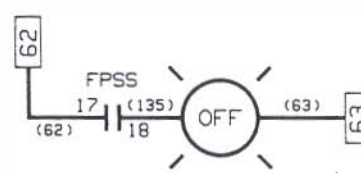

OPTION 8C - BYPASS TDEN TIMER (PBEN)

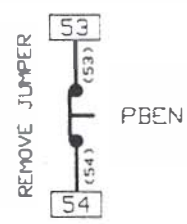

OPTION 8D - BYPASS TDNE TIMER (PBNE)

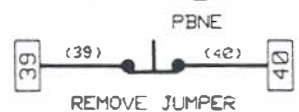

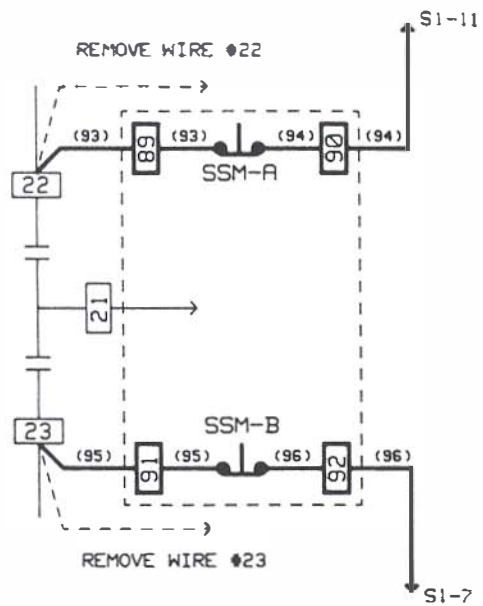
OPTION 9 - MAINTENANCE SELECTOR SWITCH

- OPTION 12C - NORMAL POSITION LIGHT (NL)
INDICATES LOAD IS CONNECTED TO NORMAL

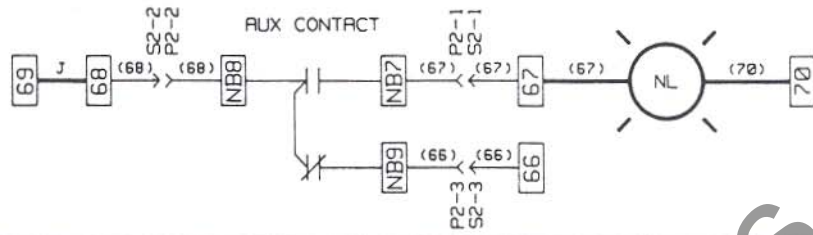

- OPTION 12D - EMERGENCY POSITION LIGHT (EL)
INDICATES LOAD IS CONNECTED TO EMERGENCY

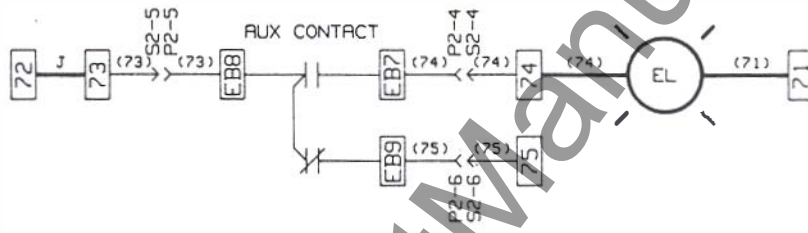

- OPTION 12G - NORMAL SOURCE LIGHT (SN)
INDICATES NORMAL SOURCE AVAILABLE

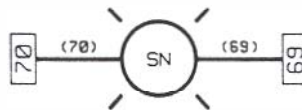

- OPTION 12H - EMERGENCY SOURCE LIGHT (SE)
INDICATES EMERGENCY SOURCE AVAILABLE



- OPTION 14C - NORMAL AUXILIARY RELAY (NRA)
 PROVIDES ADDITIONAL RELAY CONTACTS ON NORMAL

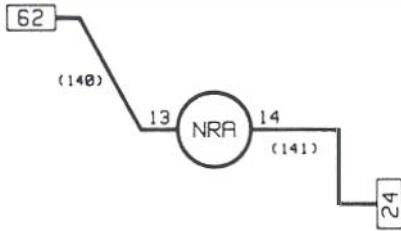

NOTE: CUSTOMER CONTACTS ARE ON RELAY SOCKET
 SEE SOCKET DIAGRAM BELOW

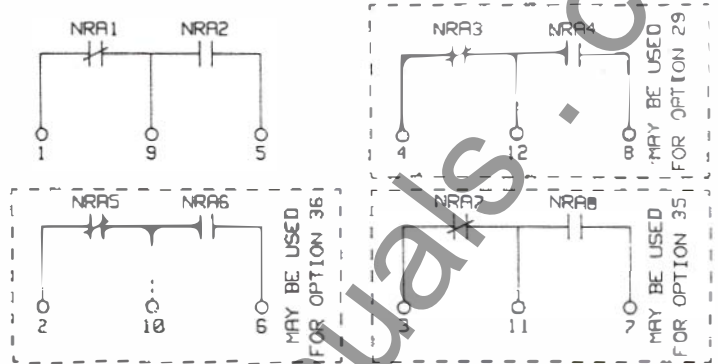

- OPTION 14D - EMERGENCY AUXILIARY RELAY (ERA)
 PROVIDES ADDITIONAL RELAY CONTACTS ON EMERGENCY



NOTE: CUSTOMER CONTACTS ARE ON RELAY SOCKET
 SEE SOCKET DIAGRAM BELOW

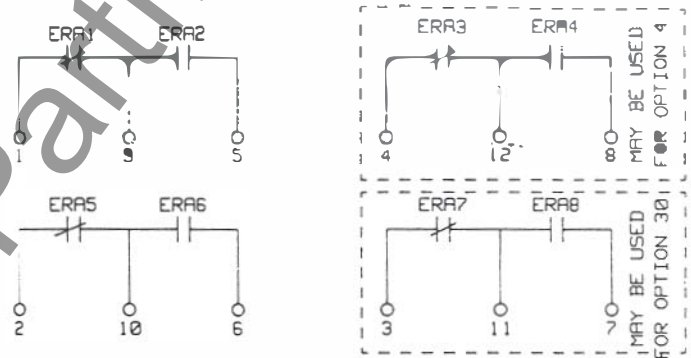

NRA - ERA SOCKET DIAGRAM

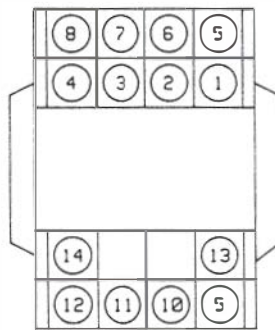

OPTION 18E - VOLTMETER

	HANDLE POSITION					
	NORMAL			EMERGENCY		
	1-3	2-3	1-2	1-2	2-3	1-3
1 - 2				X		X
3 - 4	X		X			
5 - 6					X	
7 - 8		X				
9 - 10						X
11 - 12	X					
13 - 14					X	
15 - 16		X	X			

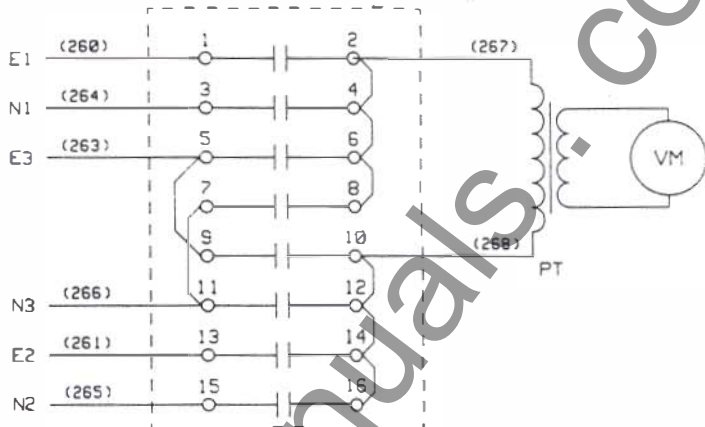

OPTION 18F - AMMETER

	HANDLE POSITION					
	OFF	1	2	3		
1 - 2	X					
3 - 4	X					
5 - 6	X					
7 - 8	X					
9 - 10	X					
11 - 12	X					

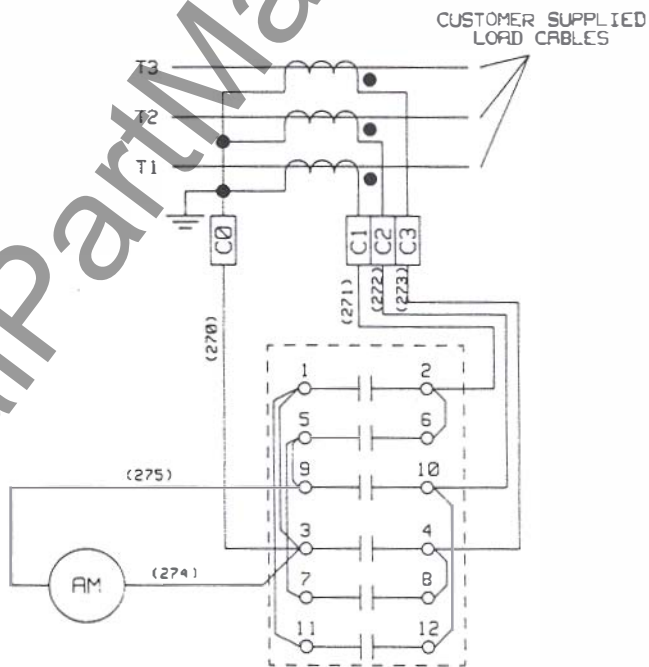

OPTION 18G - FREQUENCY METER

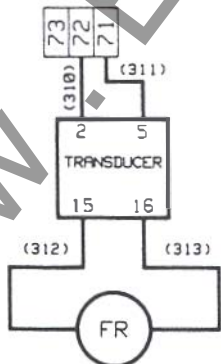

OPTION 18H - RUNNING TIME METER

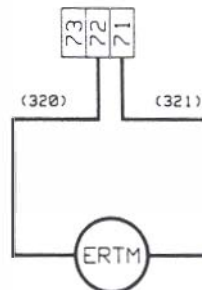

- OPTION 23C - PLANT EXERCISER RUN ENGINE AT SPECIFIED TIME (NO LOAD)

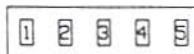
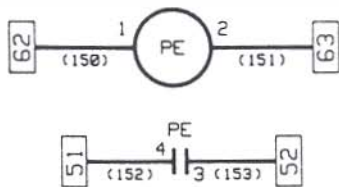

PE TERMINAL BLOCK

- OPTION 23I = 23D W/FAILS SAFE
- OPTION 23J = 23G W/FAILS SAFE

- OPTION 23D - PLANT EXERCISER RUN ENGINE AT SPECIFIED TIME (LOAD)

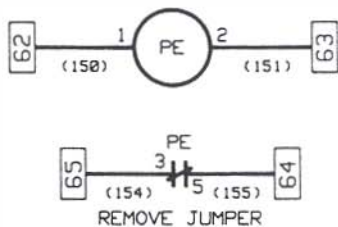

FAILSAFE CIRCUIT

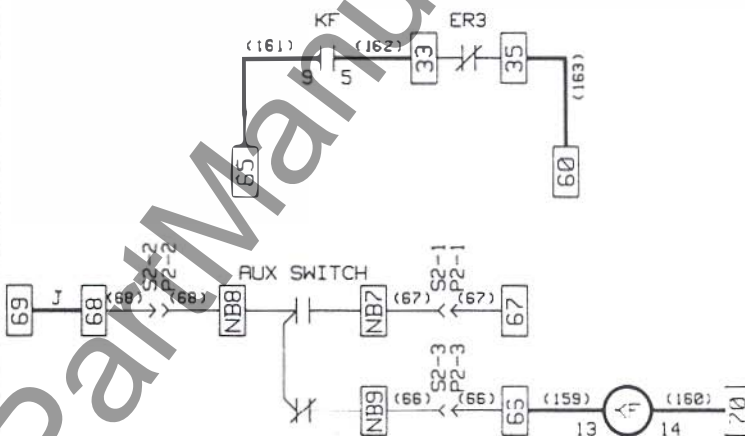

- OPTION 23G - PLANT EXERCISER RUN ENGINE AT SPECIFIED TIME (SWITCH SELECTABLE LOAD OR NO LOAD)



	ENGINE RUN	BYPASS	LOAD TIME
1 — 2	X		
5 — 6		X	
7 — 8	X		
9 — 10	X	X	
11 — 12			X

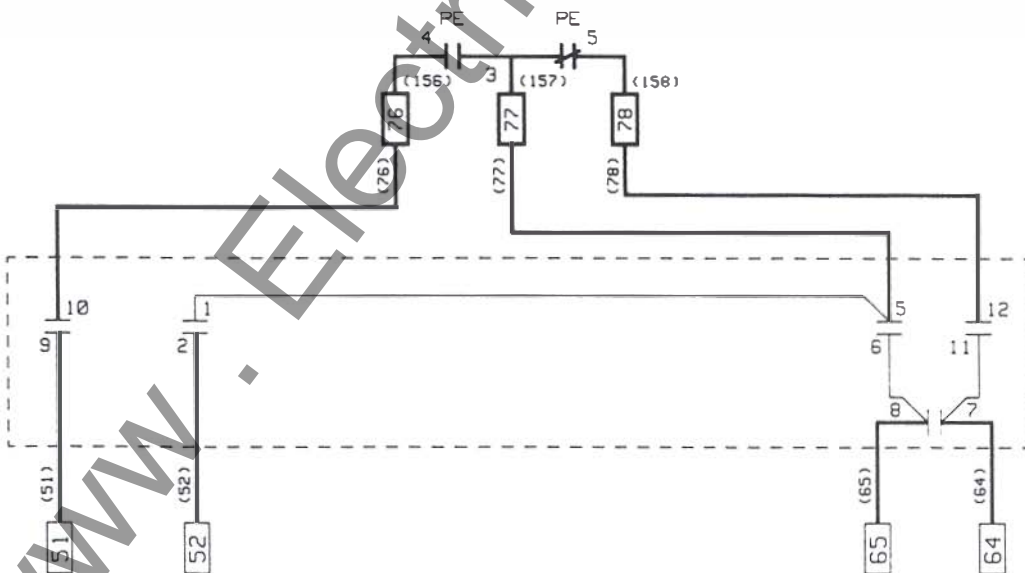

REMOVE JUMPER 64-65

- OPTION 28A - INTELLIGENCE CIRCUIT FUSES
FUSES NON-ESSENTIAL CIRCUITRY ONLY

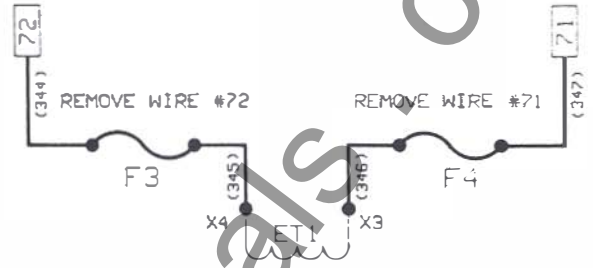
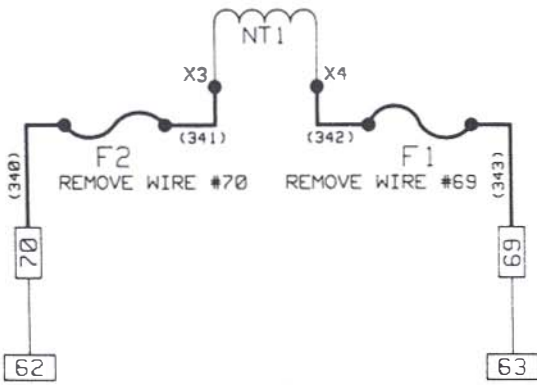

- OPTION 30 - TIME DELAY CRANK LIMITER (TDCL)
INTERUPTS ENGINE START CIRCUIT IF VOLTAGE DOES NOT APPEAR WITHIN A PRESELECTED TIME

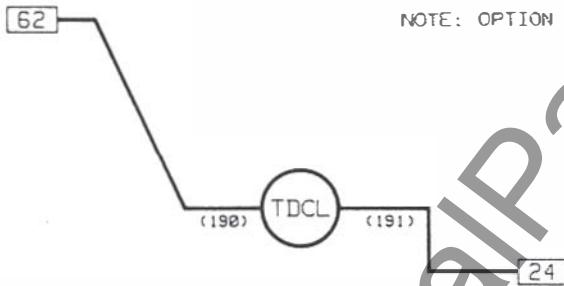

NOTE: OPTION 14d REQUIRED

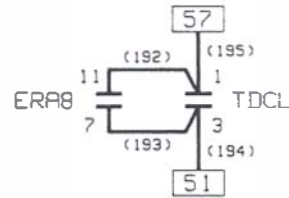

- OPTION 31B - AUDIBLE ALARM W/SILENCE SWITCH
ALARM WHEN ATS IS CONNECTED TO EMERGENCY

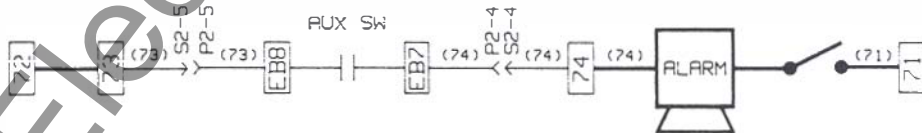

OPTION 31 ONLY

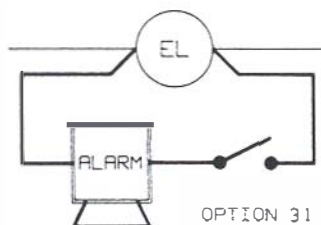

OPTION 31 WITH OPTION 12D

OPTION 29E - MANUAL RETURN TO NORMAL (NMPB)

REQUIRES OPTION 14C
OPTION 3 MAY NOT BE USED

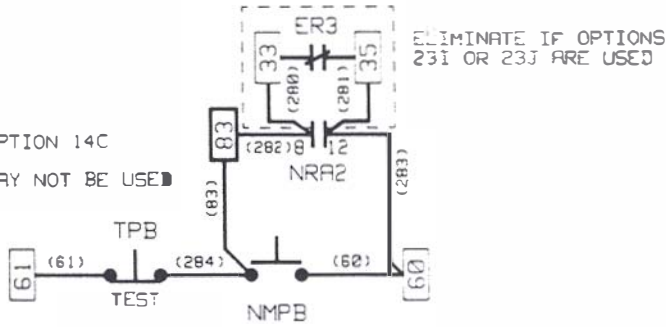

OPTION 29J AUTOMATIC/MANUAL RETURN TO NORMAL

REQUIRES OPTION 14C

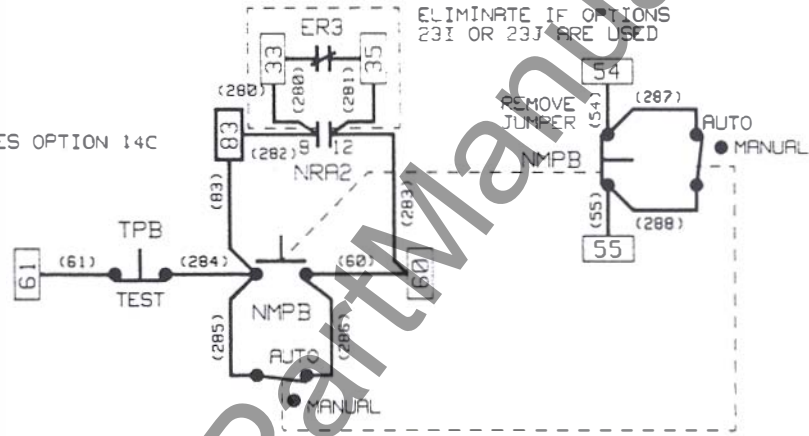

OPTION 29G - AUTOMATIC/MANUAL OPERATION

REQUIRES OPTION 14C

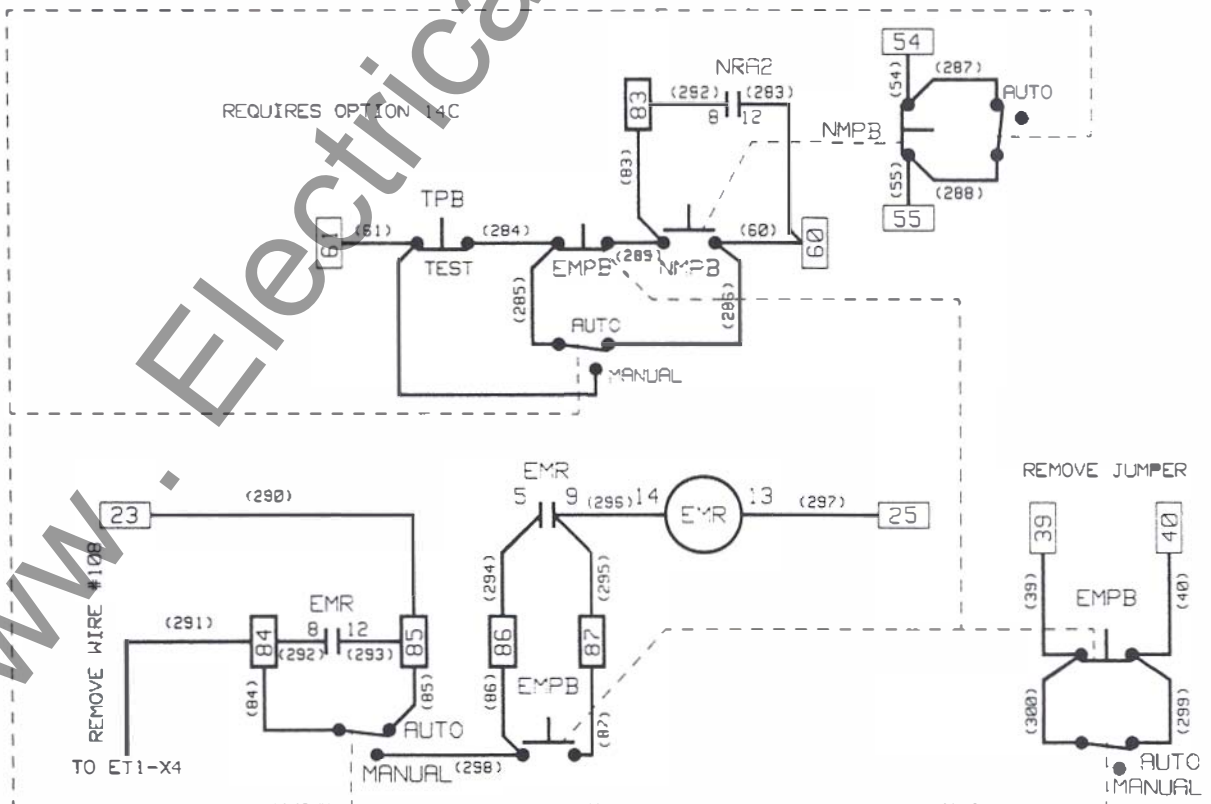

Option 16 SPB Digitrip (2000 Amp or Less)

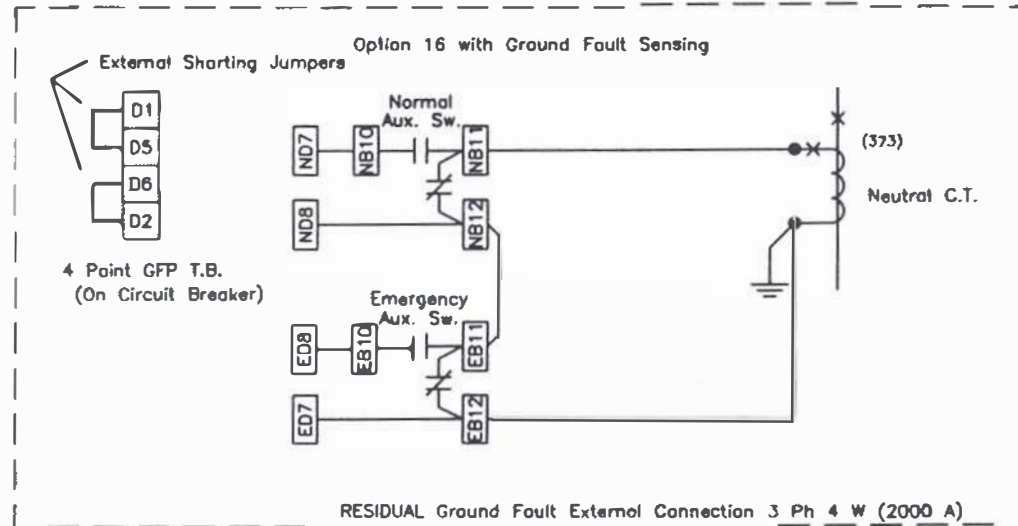
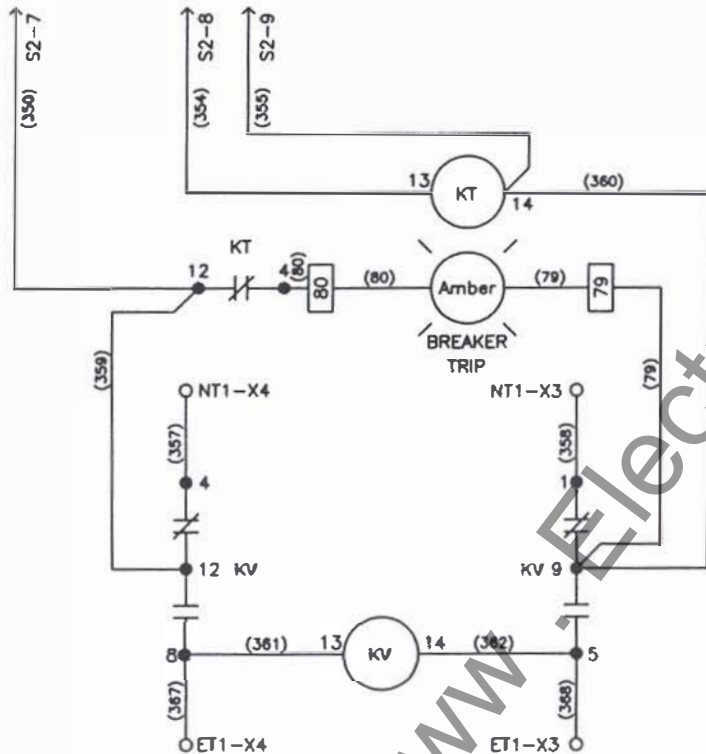
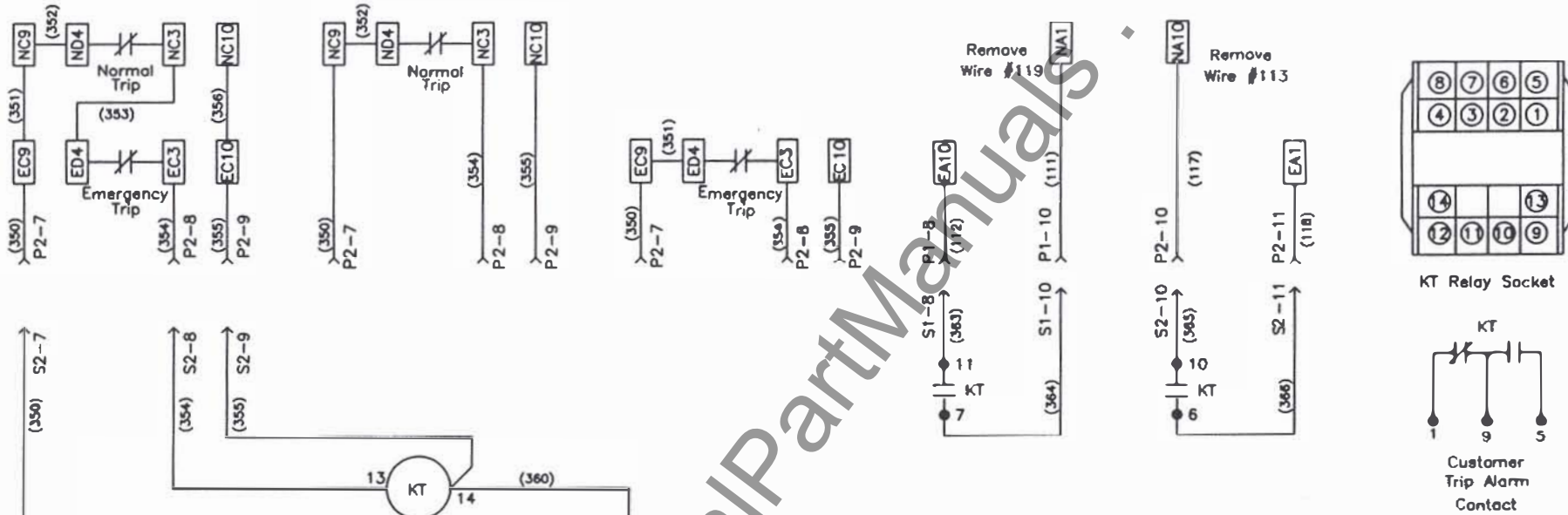



OPTION 35 - PRETRANSFER SIGNAL DEVICE
(OPTION 14 REQUIRED)

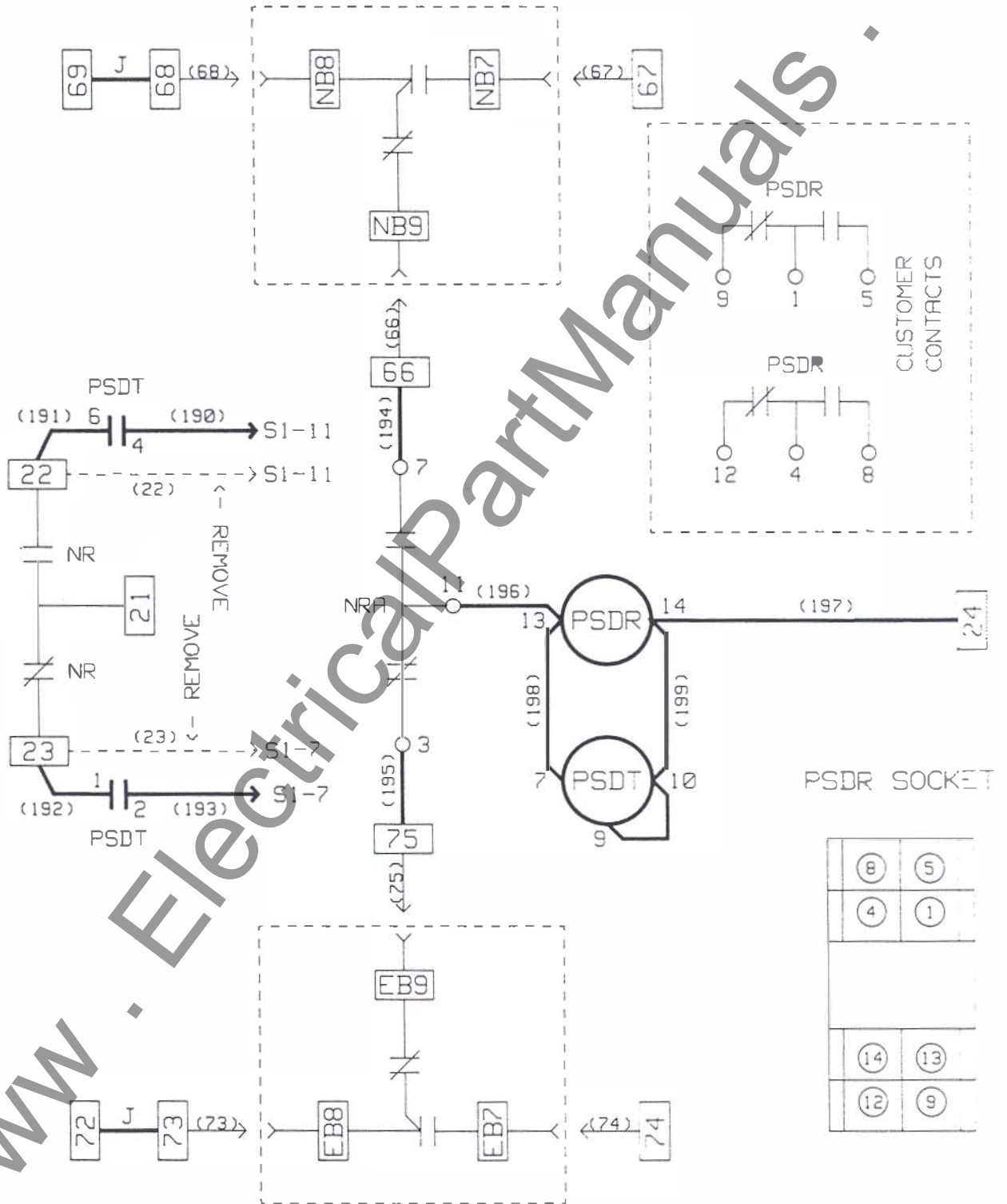

8	5
4	1
14	13
12	9

OPTION 37 - SERVICE ENTRANCE
(MUST USE OPTION 16)

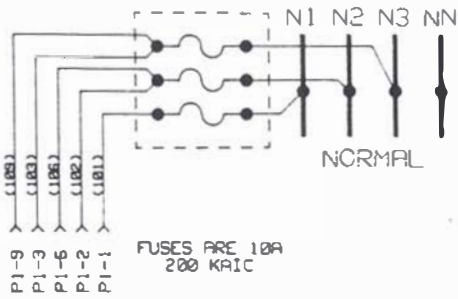

KV IS PROVIDE
W/ OPTION 16

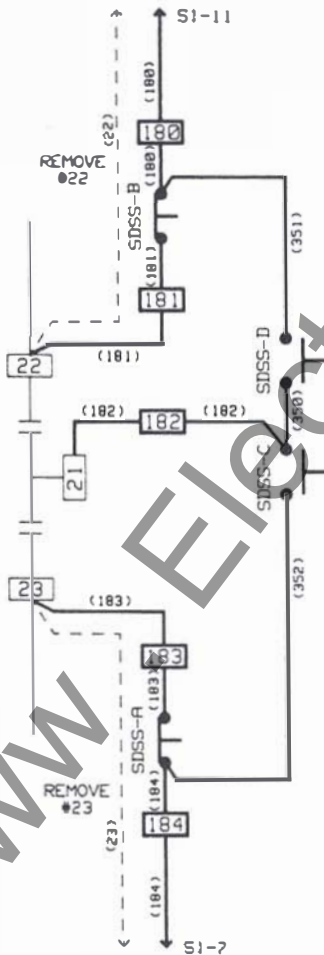
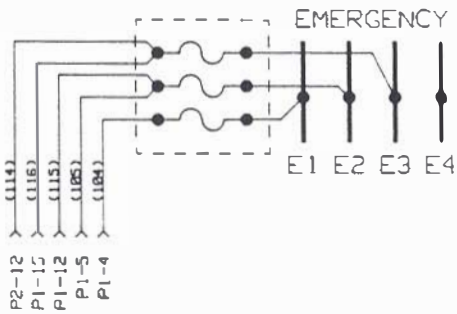
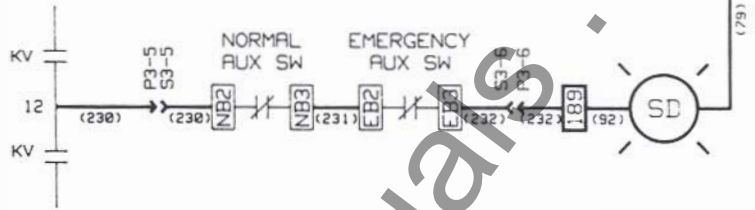

SERVICE DISCONNECT SEL SW	1	2	3	4	5	6	7	8	9	10	11	12
DISCONNECT			X	X								
ENERGIZE	X	X			X	X						

KEY LOCKED
KEY REMOVABLE
IN "DISCONNECTED" POSITION

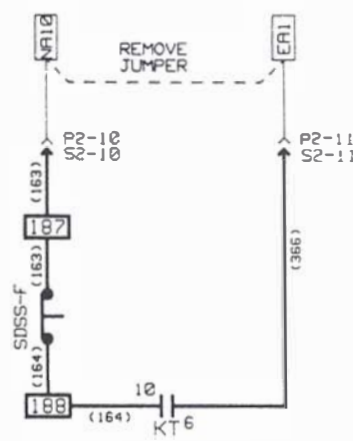
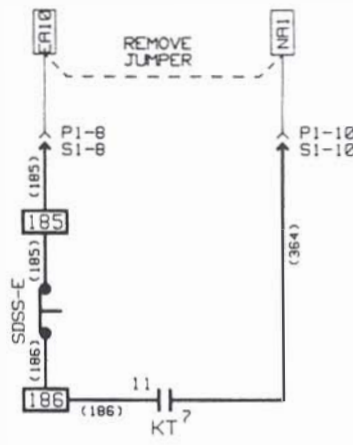

www.ElectricalPartManuals.com

COMBINATION WIRING

OPTIONS 16, 32, 35, 36, AND 37

THIS DRAWING SHOWS INTER WIRING OF THESE OPTIONS WHEN COMBINED

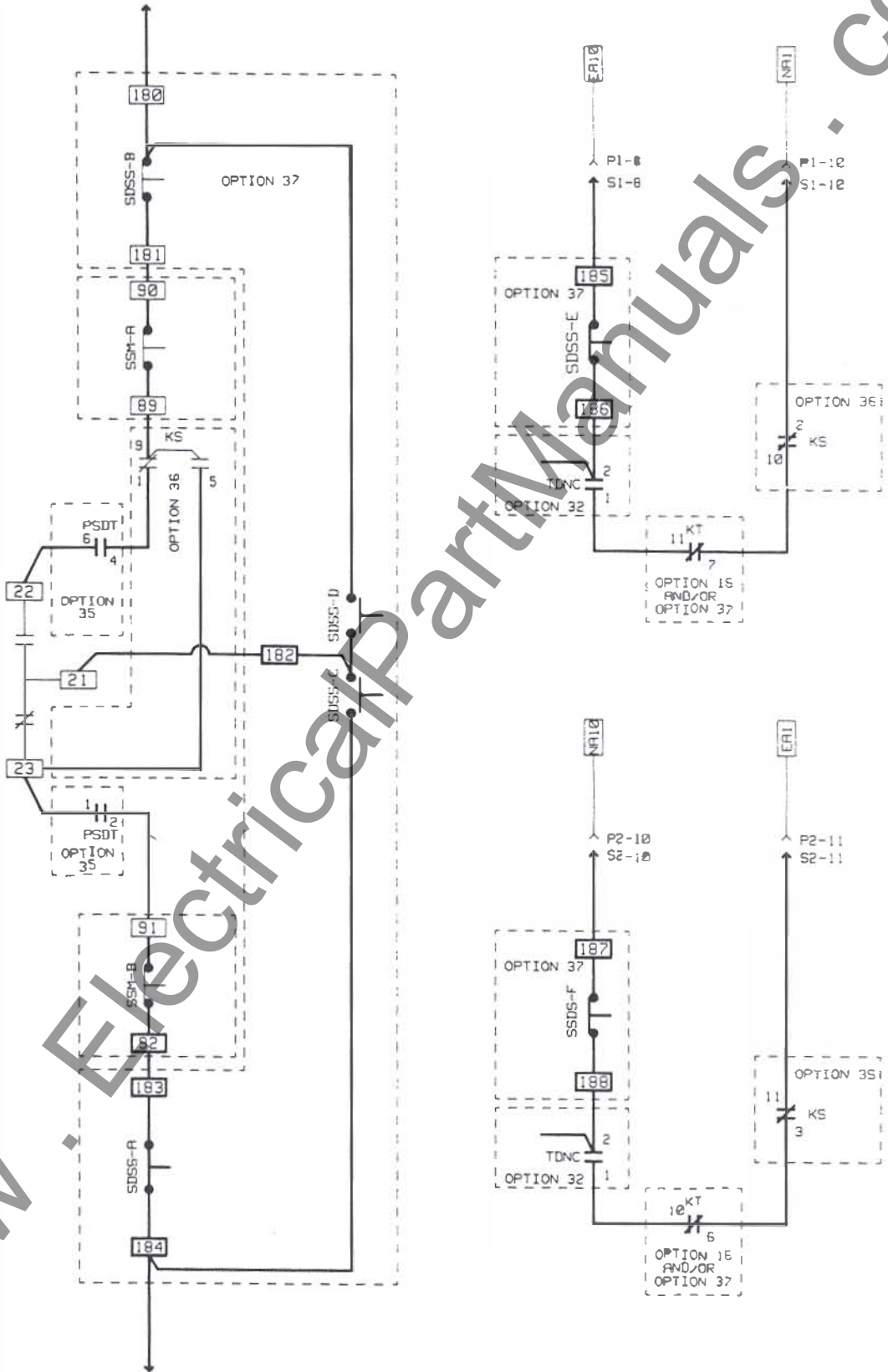

www.ElectricalPartManuals.com

Westinghouse SPB Automatic Transfer Switch
Legend for Wiring Diagram Symbols

Symbol	Description
AM	Ammeter
Ex	Power Terminal, Emergency Source (x = Terminal Number)
EASx	Emergency Lockout (x = contact number)
EC	Engine Cooloff Relay Coil
ECx	Engine Cooloff Relay Contact (x = contact number)
EL	Emergency Position Indicator Light
EMPB	Emergency Pushbutton for Manual Operation
EMR	Emergency Relay (Manual Operation)
ER	Emergency Relay Coil
ERx	Emergency Relay Contact (x = contact number)
ERA	Emergency Auxiliary Relay Coil
ERAx	Emergency Auxiliary Relay Contact (x = Contact Number)
ERTM	Generator Run Time Meter
ESx	Emergency Auxiliary Switch (x = contact number)
ET1	Emergency Transformer (Line Voltage to 120vac - 2 windings)
ET2	Emergency Transformer (120 to 24vac CT)
ET3	Emergency Transformer (Line Voltage to 12vac)
ET4	Emergency Transformer (Line Voltage to 12vac)
FPSS	Four Position Selector Switch (Option 6H)
FR	Frequency Meter
Fx	Fuse (x = Fuse Number)
KF	Failsafe Relay
KS	Load Shed Relay
KT	Trip Relay (Used w/Option 16)
KV	Voting Relay
MSS	Maintenance Selector Switch
NASx	Normal Lockout (x = contact number)
Nx	Power Terminal, Normal (x = Terminal number)
NL	Normal Position Indicator Light
NMPB	Normal Pushbutton for Manual Operation
NR	Normal Relay Coil
NRx	Normal Relay Contact (x = contact number)
NRA	Normal Auxiliary Relay Coil
NRAx	Normal Auxiliary Relay Contact (x = contact number)
NSx	Normal Auxiliary Switch (x = contact number)
NT1	Normal Transformer (Line Voltage to 120vac - 2 windings)
NT2	Normal Transformer (120 to 24vac CT)
NT3	Normal Transformer (Line Voltage to 12vac)
NT4	Normal Transformer (Line Voltage to 12vac)
Px-y	Plug (x = number, y = Terminal number)
PBEN	Bypass TDEN Pushbutton
PBNE	Bypass TDNE Pushbutton
PBRE	Pushbutton Reset Emergency Trip
PBRN	Reset Normal Breaker Trip Pushbutton
PE	Plant Exerciser
PSDR	Pre-Transfer Signal Device Relay
PSDT	Pre-Transfer Signal Device Timer
PSS	Preferred Source Selector Switch
Sx-y	Socket (x = number, y = Terminal number)
SDL	Service Disconnect Light
SDSS	Service Disconnect Selector Switch
SD	Services Disconnected Light
SE	Emergency Source Available Indicator Light
SN	Normal Source Available Indicator Light
Tx	Power Terminal, Load (x = Terminal Number)
TDCL	Time Delay Crank Time Limiter
TDEC	Time Delay Engine Cool Down
TDEN	Time Delay Emergency to Normal
TDES	Time Delay Engine Start
TDNC	Time Delay Neutral
TDNE	Time Delay Normal to Emergency
TE	Emergency Trip Indicator Light
TM	Transfer Motor and Brake
TN	Normal Trip Indicator Light
TPB	Test Pushbutton
TSS	Test Selector Switch
VM	Voltmeter

Zero Sequence Ground Fault Sensing Non-Separately Derived System

