

**Cutler-Hammer  
Beaver, PA**

**Automatic Transfer Switch**

**Type ATSBM Wiring Diagrams**

Cutler-Hammer  
Power Distribution Components Division  
One Tuscarawas Road  
Beaver, PA 15009

Copyright 1995 by Eaton/Cutler-Hammer Inc.  
All Rights Reserved

Version 2.3 12-17-92

# Cutler-Hammer Automatic Transfer Switch Wiring Diagrams

## Directions for Use

The drawing package can be used as a point to point wiring diagram for maintenance and diagnostic purposes for Solid State Logic Transfer Switches, 100 -1000 amperes, all voltages.

This document contains the following wiring information:

**Page 1**

**Basic Solid State Intelligence Panel Wiring exclusive of added option functions**

**Page 2**

**Power Switching Panel basic wiring 100, 400, 600, 800, 1000 amperes exclusive of added option functions.**

**Page 3**

**Power Switching Panel basic wiring 150 - 300 amperes exclusive of added option functions.**

**Pages 4 - 15**

**Wiring for optional functions**

**Page 16**

**Legend Sheet describing symbols used throughout this document**

**Note: Unnumbered sheets may be added to this document on specific occasions to illustrate custom options additions per order instructions.**

**All transfer switch units will be standardly wired as indicated by Pages 1, and Pages 2 or 3. The Intelligence Panel and Power Panel are interconnected via keyed plug/socket connectors (P1-S1/P2-S2). Your specific unit may be equipped with certain optional functions as noted which require additional wiring as shown on pages 4 - 15.**

**Wiring for optionally added functions will typically interface with the basic unit wiring (Pages 1-3) which should be used as the base reference.**

**Note: BOLD lines on option wiring indicate components and wiring added to the basic wiring diagram to accomplish that specific option function.**

# Cutler-Hammer Automatic Transfer Switch

## Standard Features

### **Test Pushbutton**

Simulates a power failure in the logic. Will cause the Generator to start, and load to transfer to the Emergency Source.

### **Undervoltage Protection on NORMAL (All phases)**

Monitors the voltage on the NORMAL Source for an undervoltage condition. Should the voltage drop below a preset Dropout, the generator is started and transfer to the EMERGENCY Source takes place.

### **Engine Start Contact**

Contact that provides a closure to Engine Controller when the NORMAL Source fails.

### **Logic Disconnect**

Plugs provided to disconnect the logic circuitry for maintenance purposes.

### **Motor Disconnect**

Plug provided to disconnect the motor circuit for testing of the logic circuitry without transfer.

### **Auxiliary Contacts**

Auxiliary contacts integral to the switching devices rated at 120 VAC, 10 amps. These may be applied for customer use, and may be applied to certain customer specified options.

### **Fully Rated Neutral**

A fully rated solid neutral is supplied on all two and three pole switches. All four pole switches are supplied with switched neutral contacts of identical construction and rating as the power poles.

# SOLID STATE INTELLIGENCE PANEL

NOTE A

NOTE A:  
 TRANSFORMERS NT3, NT4 AND WIRES 183, 188 USED FOR 3 PHASE NORMAL SENSING  
 TRANSFORMERS ET3, ET4 AND WIRES 114, 116 USED FOR 3 PHASE EMERGENCY SENSING (OPTION 5F AND/OR 5G)

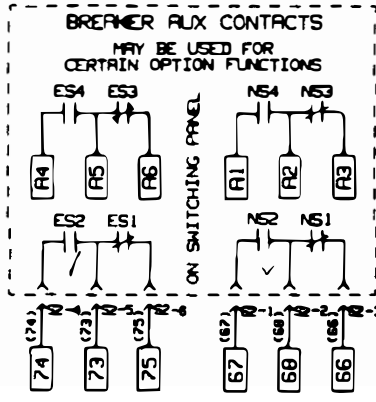
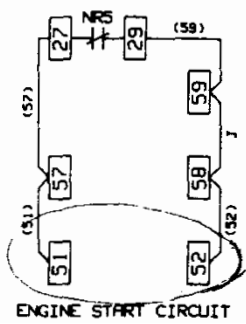
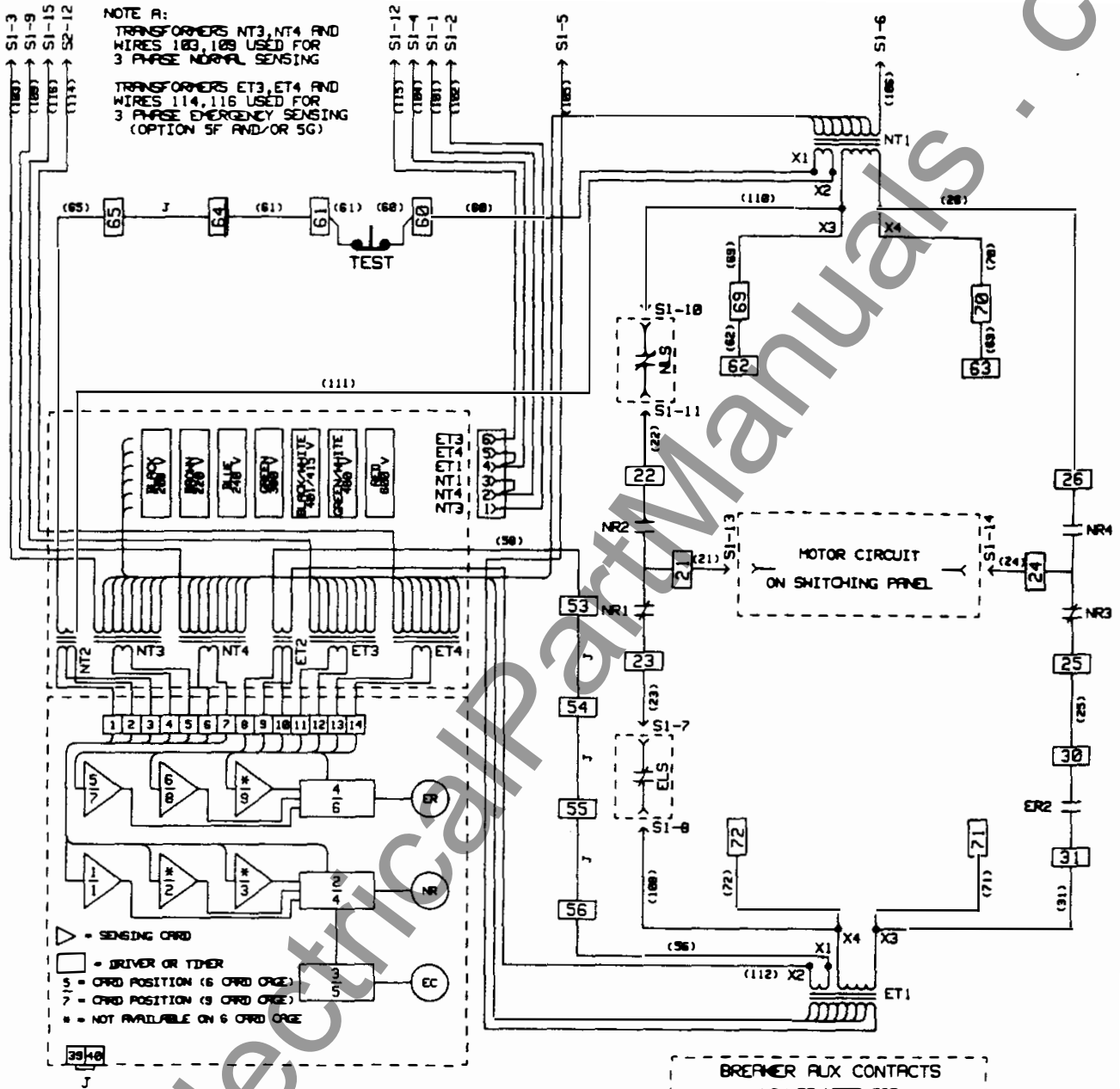



# POWER SWITCHING PANEL

100, 400, 600, 800, AND 1000 AMP

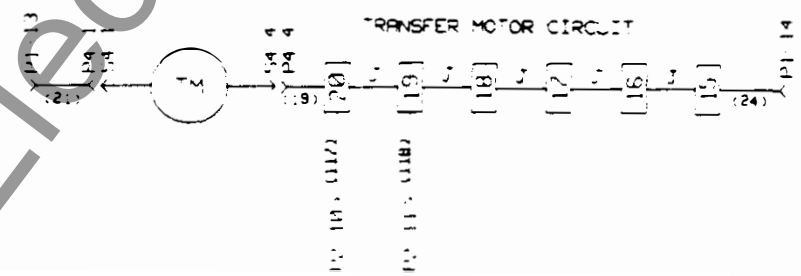
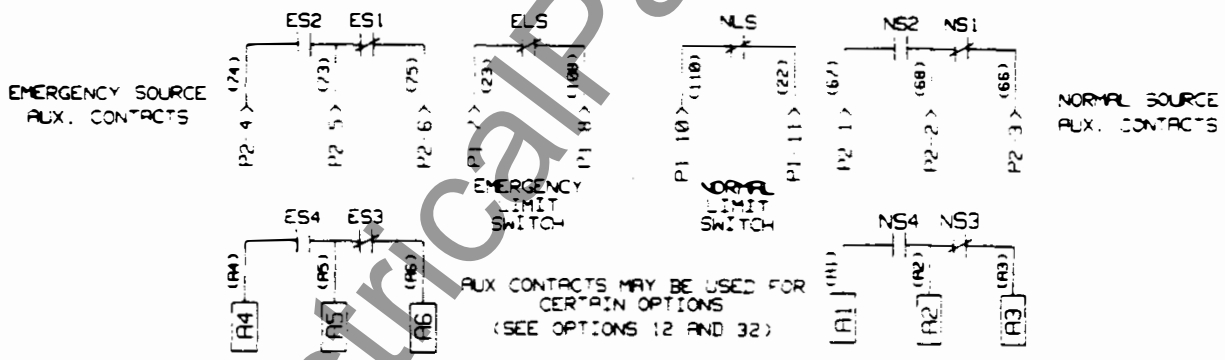
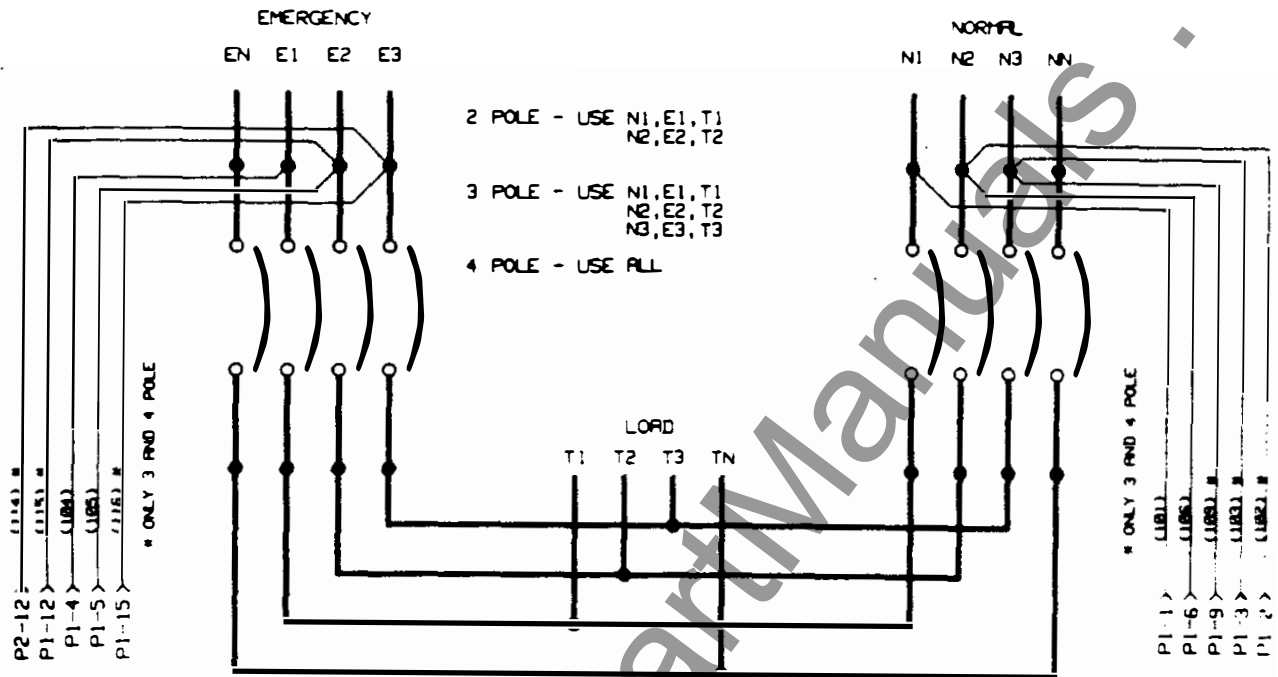

www.ElectricalPartManuals.com



# POWER SWITCHING PANEL

## 150 - 300 AMP

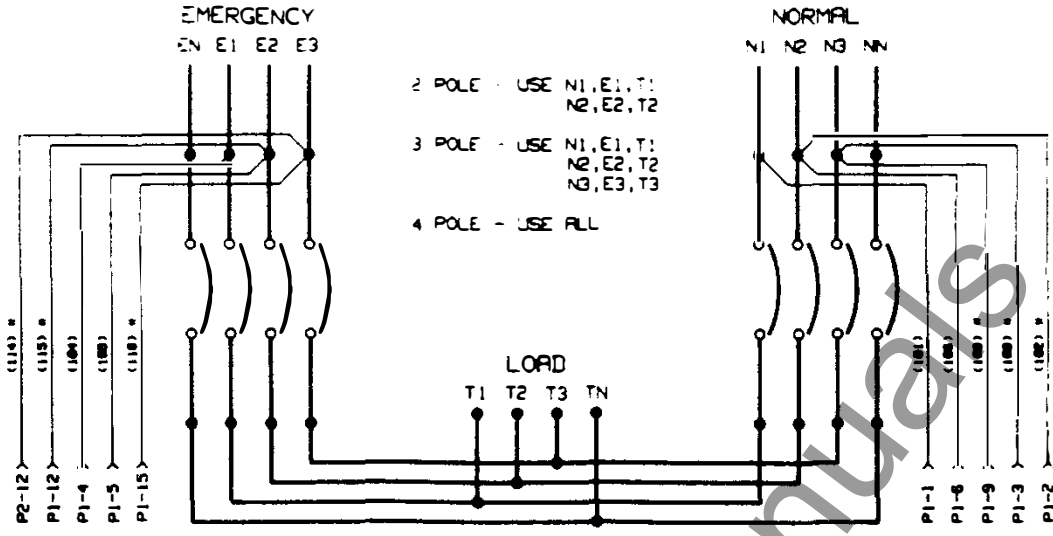

\* ONLY 3 AND 4 POLE UNITS

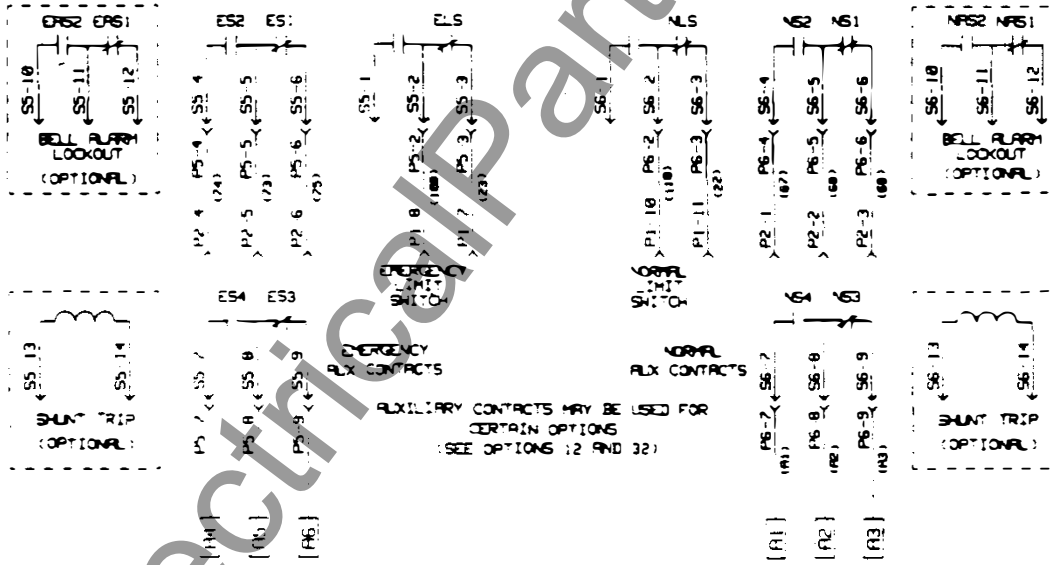

AUXILIARY CONTACTS MAY BE USED FOR CERTAIN OPTIONS (SEE OPTIONS 12 AND 32)

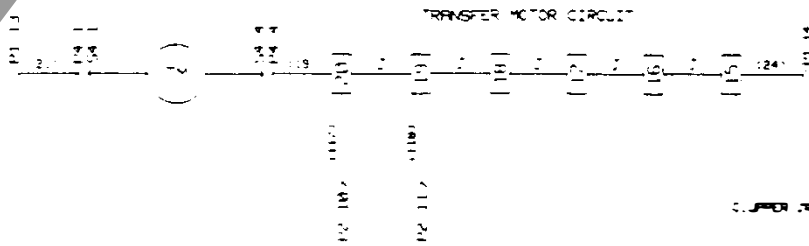

26-1000-2-7-92

www.ElectricalPartManuals.com



6 POSITION CARD CAGE

NORMAL			ENG		EMERGENCY
1	2	3	4	5	6
UNDERVOLTAGE STD	DRIVER (OPTION 3)	BLANK (OPTION 4)	DRIVER (OPTION 1)	BLANK (OPTION 5)	BLANK (OPTION 5)



9 POSITION CARD CAGE

NORMAL			ENG		EMERGENCY			
1	2	3	4	5	6	7	8	9
UNDERVOLTAGE STD	BLANK (OPTION 26)	BLANK (OPTION 26)	DRIVER (OPTION 3)	BLANK (OPTION 4)	DRIVER (OPTION 1)	BLANK (OPTION 5)	BLANK (OPTION 5)	BLANK (OPTION 5)



OPTION 1 - TIME DELAY NORMAL TO EMERGENCY (TDNE)

6 POSITION CARD CAGE  
REPLACE DRIVER CARD IN POSITION 4 WITH TIMER CARD

9 POSITION CARD CAGE  
REPLACE DRIVER CARD IN POSITION 6 WITH TIMER CARD



OPTION 3 - TIME DELAY EMERGENCY TO NORMAL (TDEN)

6 POSITION CARD CAGE  
REPLACE DRIVER CARD IN POSITION 2 WITH TIMER CARD

9 POSITION CARD CAGE  
REPLACE DRIVER CARD IN POSITION 4 WITH TIMER CARD



OPTION 4 - TIME DELAY ENGINE COOLOFF (TDEC)

6 POSITION CARD CAGE  
REPLACE BLANK CARD IN POSITION 3 WITH TIMER CARD  
ADD EC RELAY TO MOTHERBOARD

9 POSITION CARD CAGE  
REPLACE BLANK CARD IN POSITION 5 WITH TIMER CARD  
ADD EC RELAY TO MOTHERBOARD

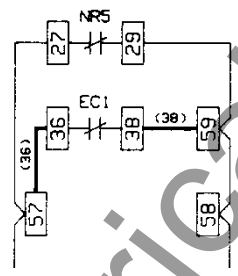

OPTION 4 ONLY

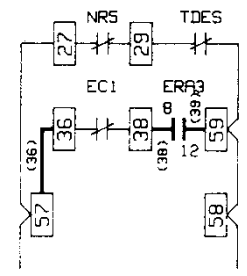

OPTION 4 WITH 2 \*\*  
\*\* REQUIRES OPTION 14D



OPTION 5 - EMERGENCY SENSING (UV,OV,UF,OF)

6 POSITION CARD CAGE  
REPLACE BLANK CARD IN POSITION 5 OR 6 WITH APPROPRIATE SENSING CARD

9 POSITION CARD CAGE  
REPLACE BLANK CARD IN POSITION 7,8 OR 9 WITH APPROPRIATE SENSING CARD



OPTION 26 - NORMAL SENSING (OV,UF,OF)

6 POSITION CARD CAGE  
NOT AVAILABLE

9 POSITION CARD CAGE  
REPLACE BLANK CARD IN POSITION 2 OR 3 WITH APPROPRIATE SENSING CARD

\* UNDERVOLTAGE SENSING ON NORMAL IS STANDARD

OPTION 2 - TIME DELAY ENGINE START (TDES)

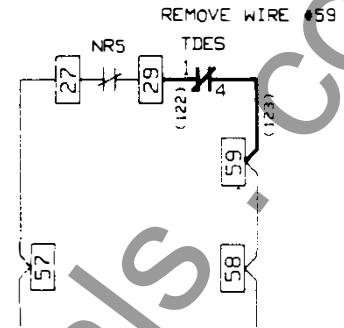
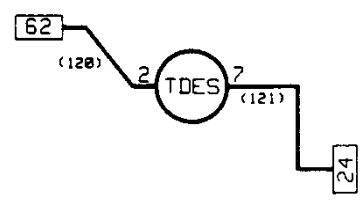

OPTION 6D - TEST SELECTOR SWITCH (TSS)



OPTION 6H - FOUR POSITION SELECTOR SWITCH (FPSS)

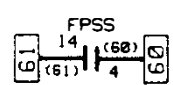

REPLACES STANDARD TEST PUSHBUTTON

FPSS	J1 10T	J1 12T	J1 14T	J1 16T	J1 18T
TEST					
AUTO					
OFF					
ENG. RUN					

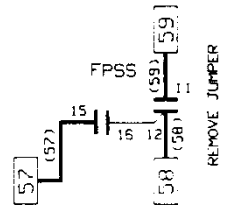
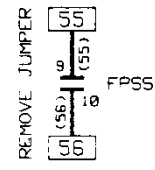
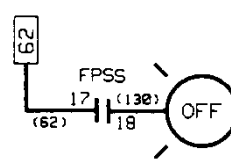

OPTION 8C - BYPASS TDEN TIMER (PBEN)

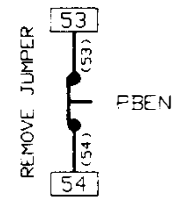

OPTION 8D - BYPASS TDNE TIMER (PBNE)

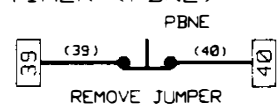



- OPTION 9B - MAINTENANCE SELECTOR SWITCH (MSS)  
PROVIDES A MOTOR CIRCUIT DISCONNECT TO PREVENT TRANSFER DURING ATS MAINTENANCE

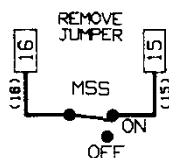

- OPTION 11D - PUSHBUTTON RESET NORMAL (PBRN)  
PROVIDES PUSHBUTTON RESET OF LOCKOUT

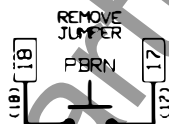

NOTE: ONLY AVAILABLE IF OPTIONS 11F, 16, OR 17 ARE PROVIDED  
NOTE: NOT AVAILABLE ON 100 AMP

- OPTION 11E - PUSHBUTTON RESET EMERGENCY (PBRE)  
PROVIDES PUSHBUTTON RESET OF LOCKOUT

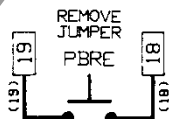

NOTE: ONLY AVAILABLE IF OPTIONS 11F, 16, OR 17 ARE PROVIDED  
NOTE: NOT AVAILABLE ON 100 AMP

- OPTION 11F - TRIP LOCKOUT (NAS) (EAS)  
PREVENTS TRANSFER AFTER BREAKER TRIP

(PROVIDED AS STANDARD WITH THERMAL MAGNETIC TRIP UNITS OPTION 16 OR 17) NOTE: NOT USED ON 100 AMP

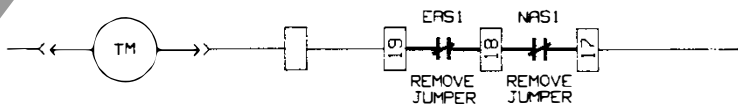

- OPTION 12C - NORMAL POSITION LIGHT (NL)  
INDICATES LOAD IS CONNECTED TO NORMAL

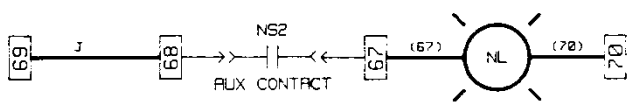

- OPTION 12D - EMERGENCY POSITION LIGHT (EL)  
INDICATES LOAD IS CONNECTED TO EMERGENCY

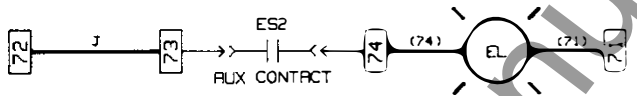

- OPTION 12G - NORMAL SOURCE LIGHT (SN)  
INDICATES NORMAL SOURCE AVAILABLE



- OPTION 12H - EMERGENCY SOURCE LIGHT (SE)  
INDICATES EMERGENCY SOURCE AVAILABLE

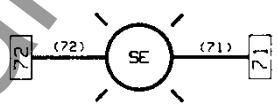

- OPTION 12L - NORMAL TRIPPED INDICATOR (TN)  
INDICATES OVERLOAD TRIP ON NORMAL

NOTE: ONLY AVAILABLE WHEN OPTION 11F IS SUPPLIED

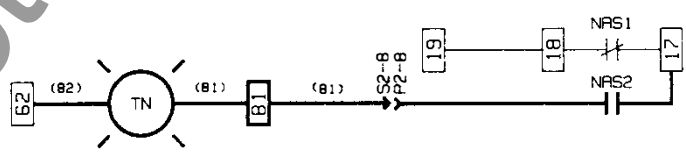

- OPTION 12M - EMERGENCY TRIPPED INDICATOR (TE)  
INDICATES OVERLOAD TRIP ON EMERGENCY

NOTE: ONLY AVAILABLE WHEN OPTION 11F IS SUPPLIED

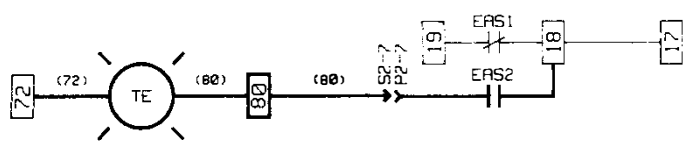

- OPTION 14C - NORMAL AUXILIARY RELAY (NRA)  
PROVIDES ADDITIONAL RELAY CONTACTS ON NORMAL

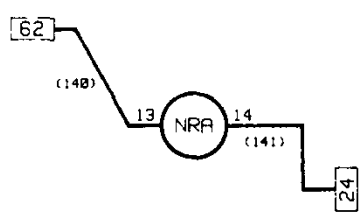

NOTE: CUSTOMER CONTACTS ARE ON RELAY SOCKET  
SEE SOCKET DIAGRAM BELOW

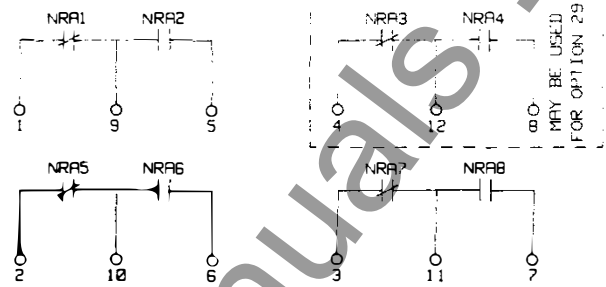

- OPTION 14D - EMERGENCY AUXILIARY RELAY (ERA)  
PROVIDES ADDITIONAL RELAY CONTACTS ON EMERGENCY



NOTE: CUSTOMER CONTACTS ARE ON RELAY SOCKET  
SEE SOCKET DIAGRAM BELOW

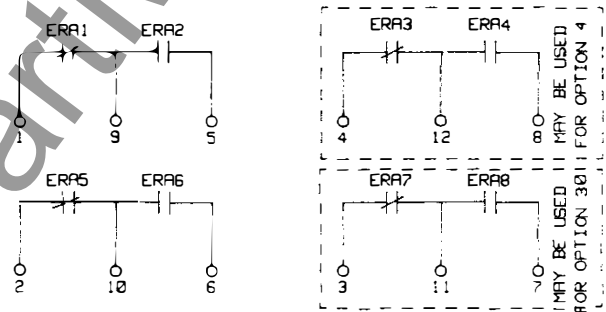

NRA - ERA SOCKET DIAGRAM

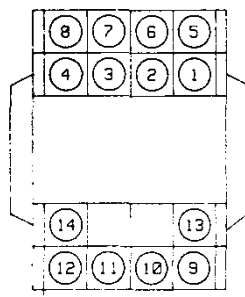

OPTION 18E - VOLTMETER

	HANDLE POSITION	HANDLE POSITION					
		NORMAL			EMERGENCY		
		1-3	2-3	1-2	1-2	2-3	1-3
1 -    2				X	X		
3 -    4	X		X				
5 -    6					X		
7 -    8		X					
9 -    10						X	
11 -    12	X						
13 -    14				X	X		
15 -    16		X	X				

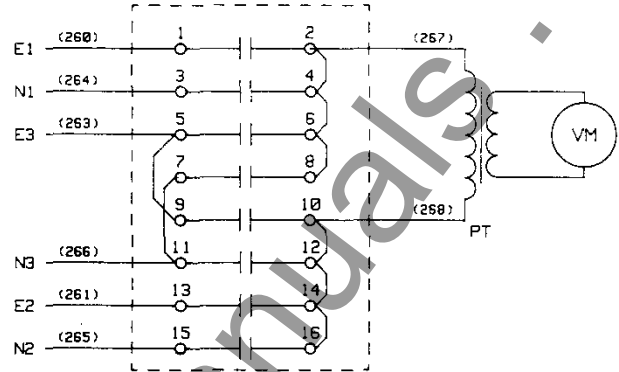

OPTION 18F - AMMETER

	HANDLE POSITION	HANDLE POSITION					
		OFF	-	1	-	2	-
1 -    2		X	X	X	X	X	X
3 -    4	X	X	X	X	X	X	X
5 -    6		X	X	X	X	X	X
7 -    8		X	X	X	X	X	X
9 -    10	X	X	X	X	X	X	X
11 -    12		X	X	X	X	X	X

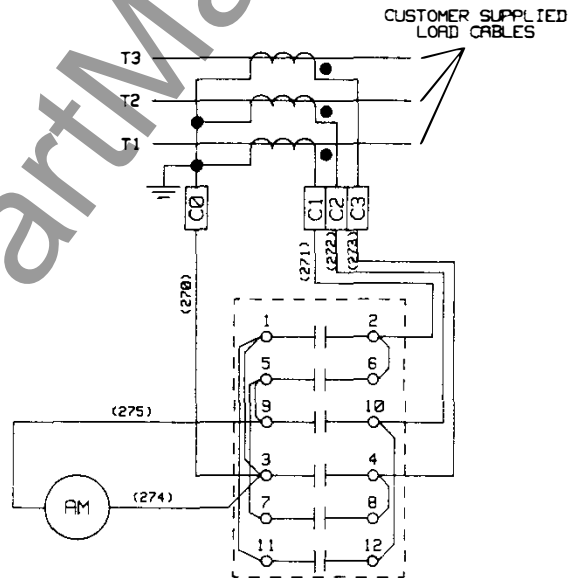

OPTION 18G - FREQUENCY METER

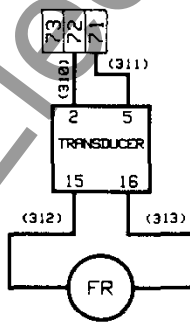

OPTION 18H - RUNNING TIME METER

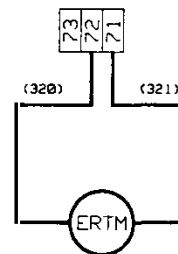

- OPTION 23C - PLANT EXERCISER  
RUN ENGINE AT SPECIFIED TIME - NO LOAD



- OPTION 23D - PLANT EXERCISER  
RUN ENGINE AT SPECIFIED TIME - LOAD



- OPTION 23I = 23D W/FAILSAFE

- OPTION 23J = 23G W/FAILSAFE

- OPTION 23G - PLANT EXERCISER  
RUN ENGINE AT SPECIFIED TIME - LOAD OR NO LOAD  
(SWITCH SELECTABLE)

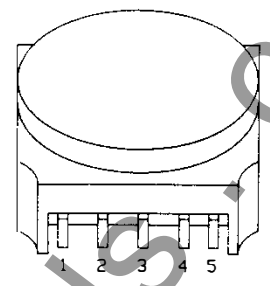
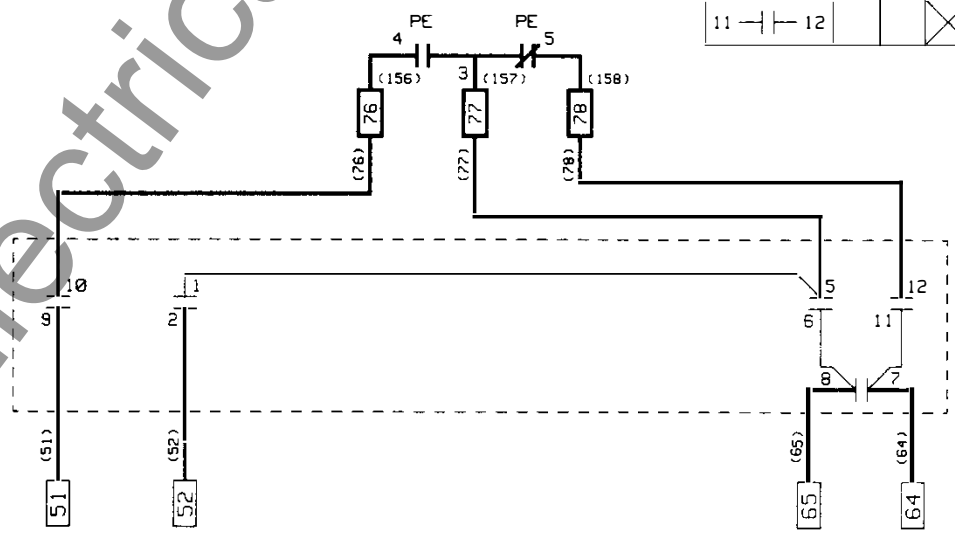
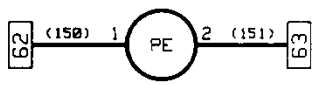

PLANT EXERCISER  
TERMINAL LAYOUT

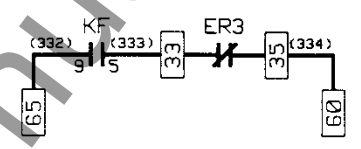

FAILSAFE CIRCUIT

	ENGINE RUN	BYPASS	LOAD TEST
1 — 2	X		
5 — 6			X
7 — 8	X	X	
9 — 10	X	X	
11 — 12			X

REMOVE JUMPER 64-65

OPTION 28A - INTELLIGENCE CIRCUIT FUSES  
FUSES NON-ESSENTIAL CIRCUITRY ONLY

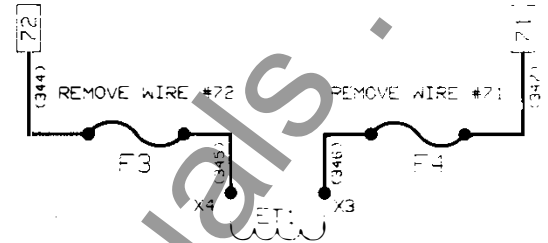
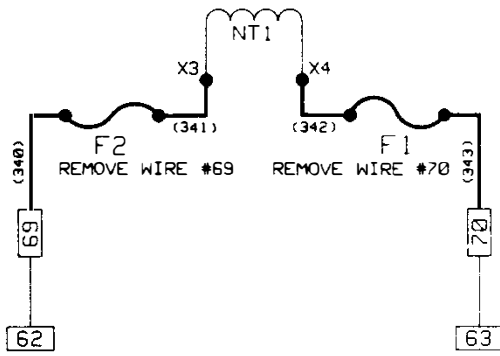

OPTION 33A - SHUNT TRIP  
(NORMAL)

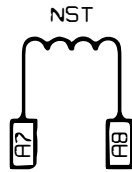

OPTION 33B - SHUNT TRIP  
(EMERGENCY)

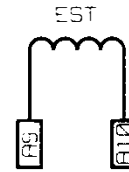

OPTION 29E - MANUAL RETURN TO NORMAL (NMPB)

REQUIRES OPTION 14C  
OPTION 3 MAY NOT BE USED

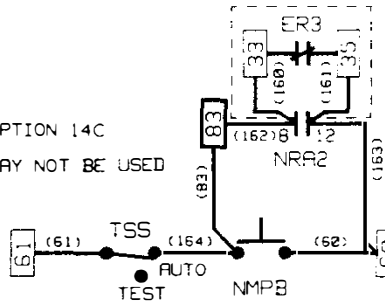

OPTION 29J AUTOMATIC/MANUAL RETURN TO NORMAL

REQUIRES OPTION 14C

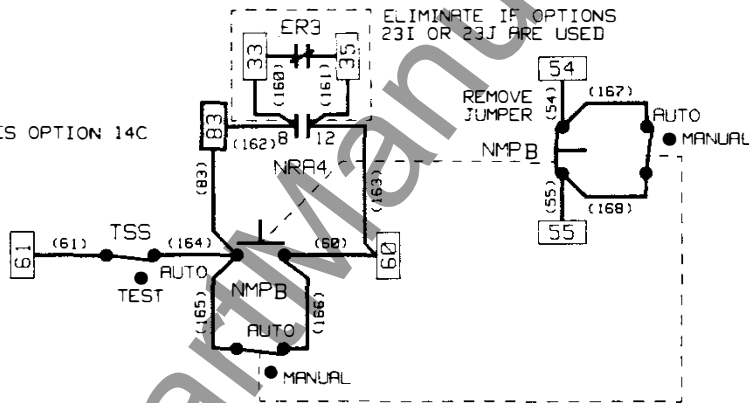

OPTION 29G - AUTOMATIC/MANUAL OPERATION

REQUIRES OPTION 14C

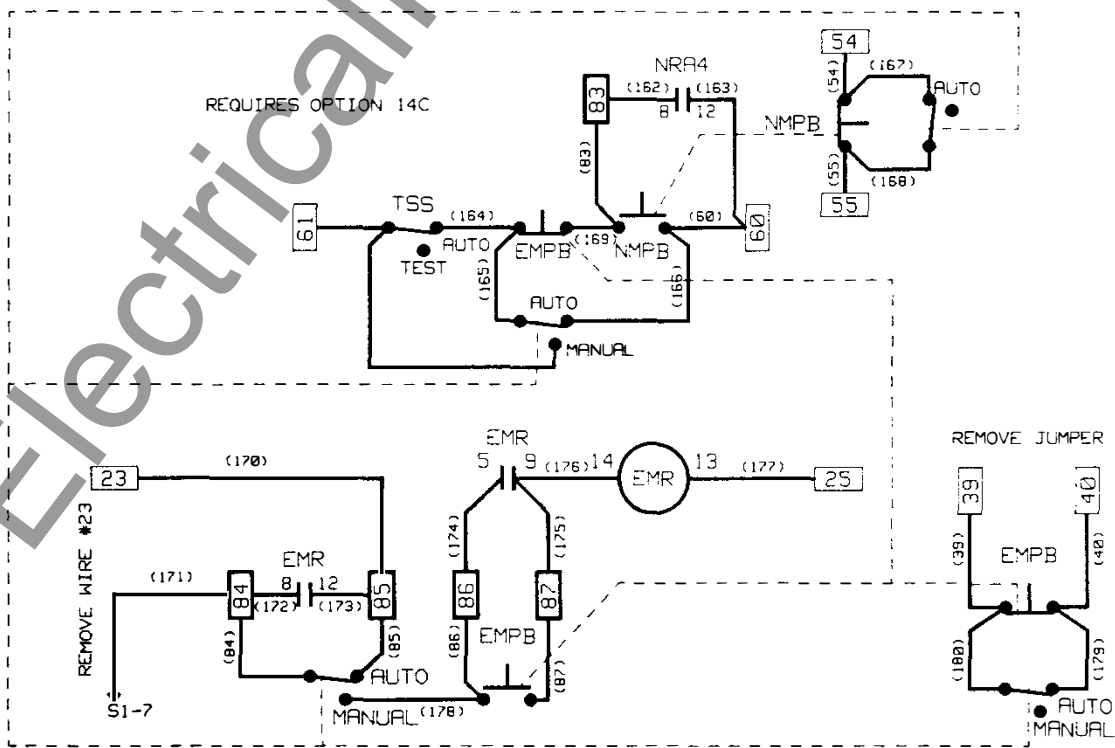

- OPTION 30 - TIME DELAY CRANK LIMITER (TDCL)  
 INTERRUPTS ENGINE START CIRCUIT IF VOLTAGE DOES NOT APPEAR WITHIN A PRESELECTED TIME

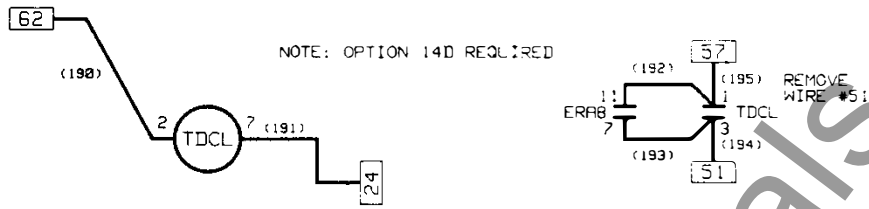

- OPTION 32A - TIME DELAY NEUTRAL (TDNC)  
 PROVIDES A TIME DELAY IN THE NEUTRAL POSITION WHEN THE LOAD IS TRANSFERRED IN EITHER DIRECTION TO PREVENT EXCESSIVE INRUSH CURRENTS DUE TO OUT-OF-PHASE SWITCHING OF INDUCTIVE LOADS

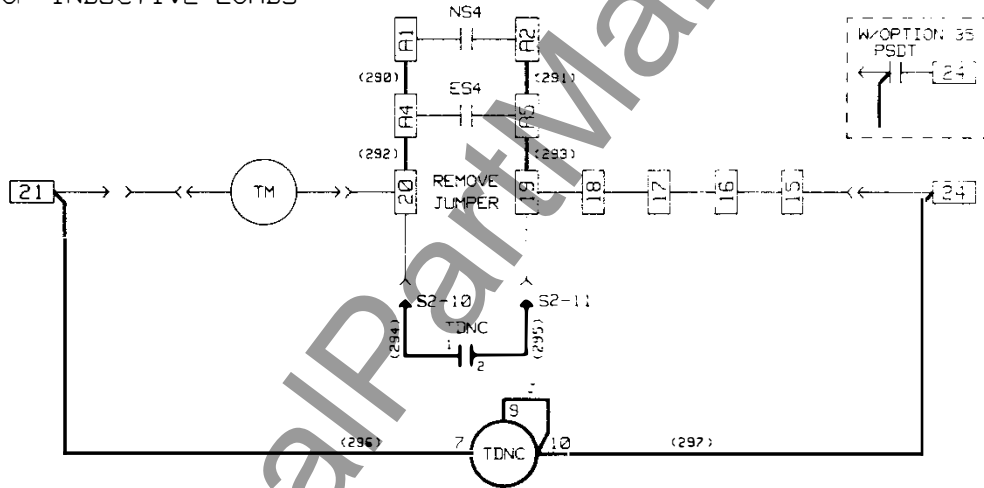

- OPTION 35A - PRETRANSFER SIGNAL DEVICE (PSD)  
 RELAY CONTACTS CHANGE STATE PRIOR TO TRANSFER WITH PRESET TIME DELAY

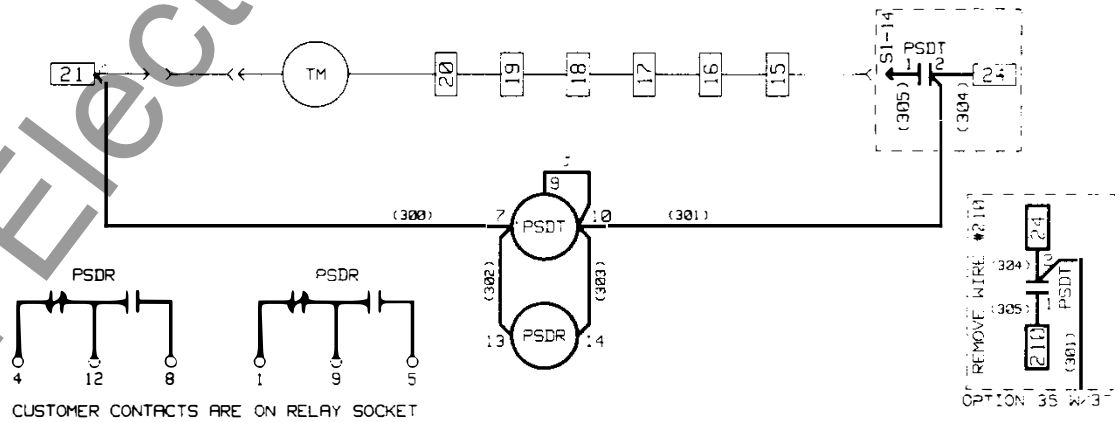



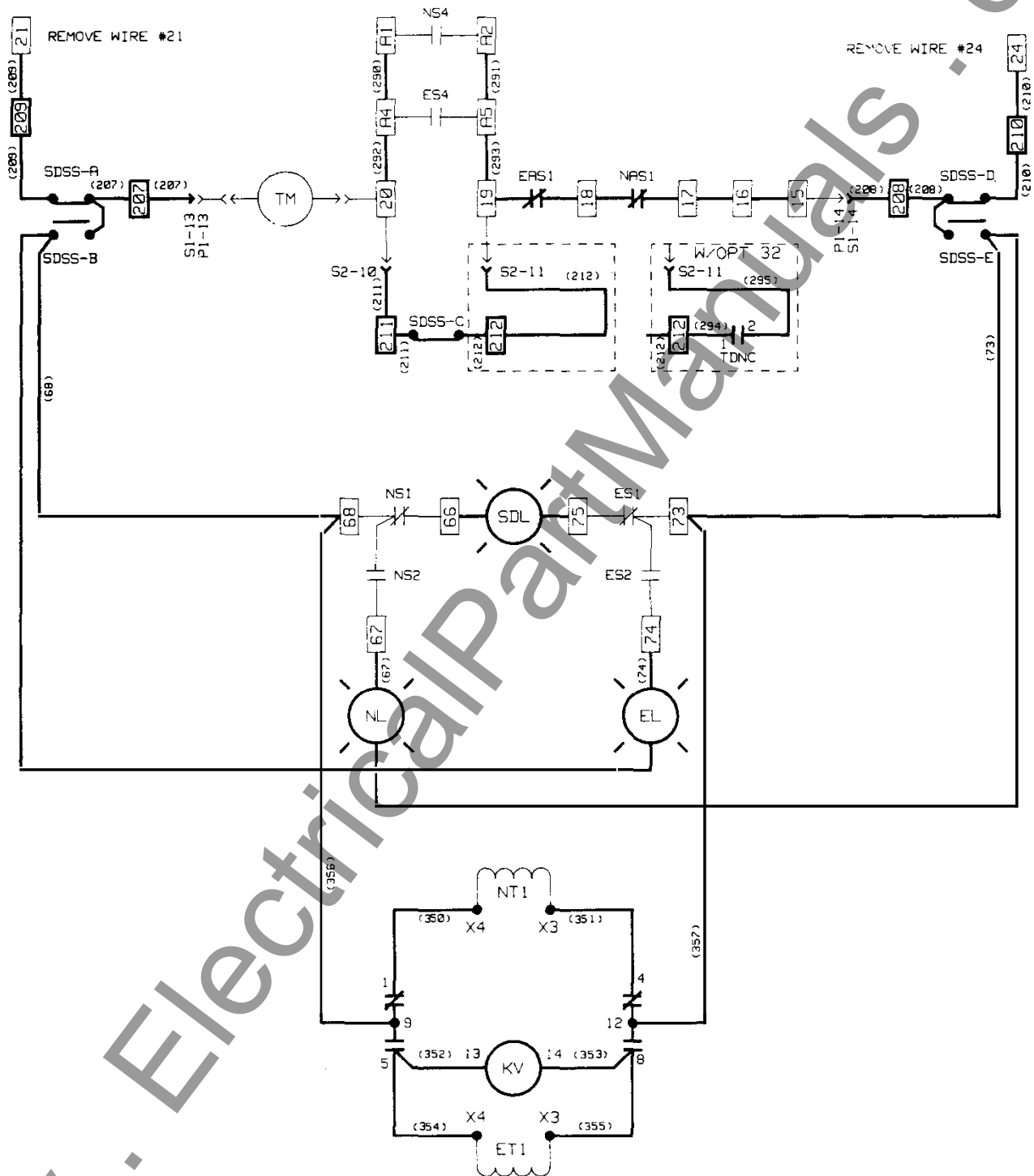

SDSS	A	B	C	D	E
DISCONNECT		X			X
ENERGIZE	X		X	X	

KEY REMOVABLE IN  
"DISCONNECT" POSITION

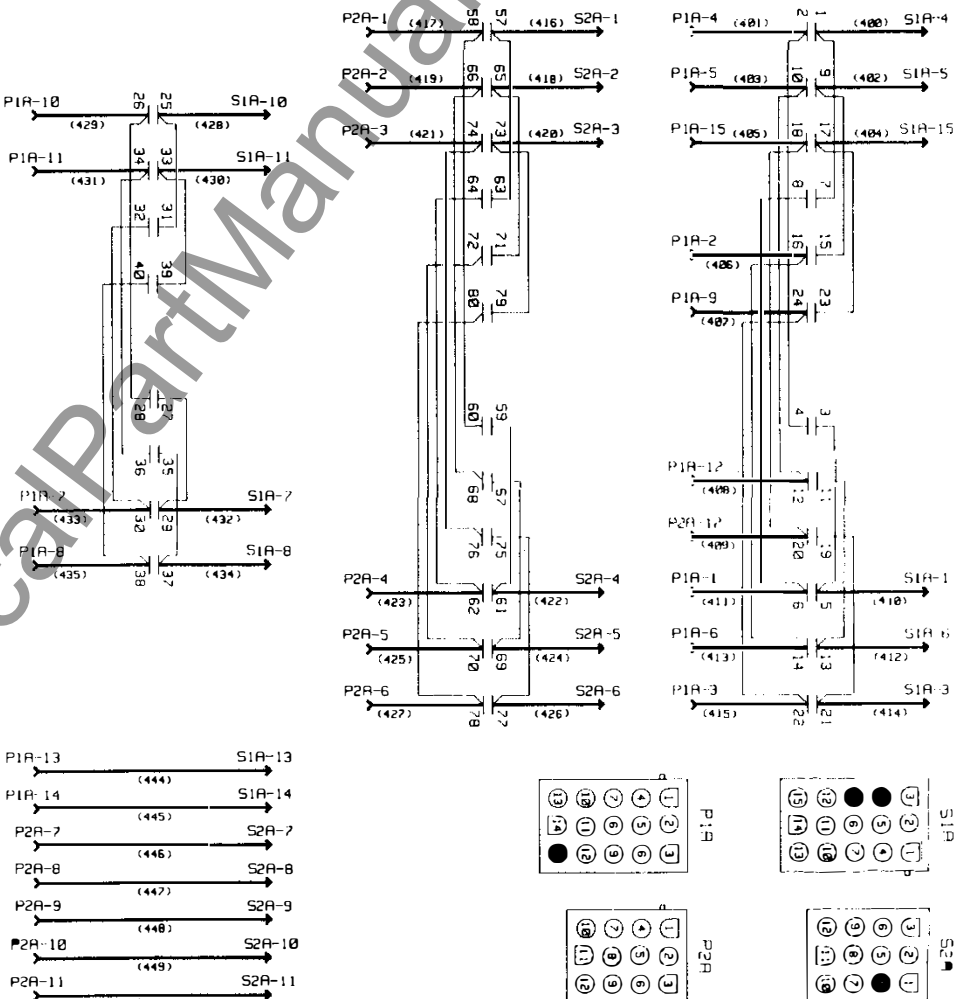

PREFERRED SOURCE SELECTOR SWITCH	NORMAL	EMERGENCY
1-10	X	X
11-12	X	X
13-16	X	X
17-18	X	X
19-20	X	X
21-22	X	X
23-24	X	X
25-26	X	X
27-28	X	X
29-30	X	X
31-32	X	X
33-34	X	X
35-36	X	X
37-38	X	X
39-40	X	X
41-42	X	X
43-44	X	X
47-48	X	X
49-50	X	X
51-52	X	X
53-54	X	X
55-58	X	X
59-60	X	X
61-62	X	X
63-64	X	X
65-66	X	X
67-68	X	X
69-70	X	X
71-72	X	X
73-74	X	X
75-76	X	X
77-78	X	X
79-80	X	X
81-82	X	X
83-84	X	X
85-86	X	X
87-88	X	X
89-90	X	X
91-92	X	X
93-94	X	X
95-96	X	X
97-98	X	X
99-100	X	X

(M) PART NO. 598B730-01

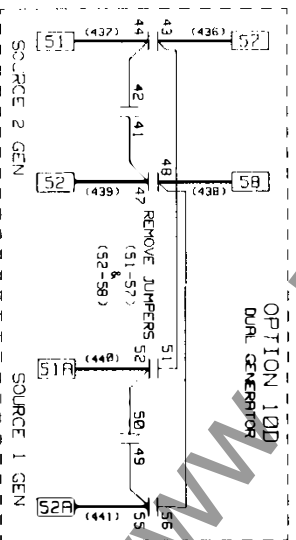
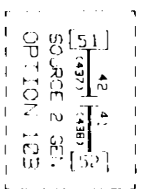
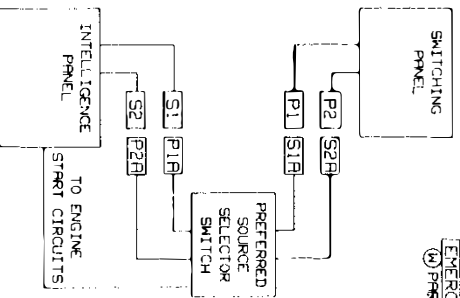

Westinghouse Automatic Transfer Switch  
Legend for Wiring Diagram Symbols

Symbol	Description
AM	Ammeter
Ex	Power Terminal, Emergency Source (x = Terminal Number)
EASx	Emergency Lockout (x = contact number)
EC	Engine Cooloff Relay Coil
ECx	Engine Cooloff Relay Contact (x = contact number)
EL	Emergency Position Indicator Light
ELS	Emergency Limit Switch
EMPB	Emergency Pushbutton for Manual Operation
EMR	Emergency Relay (Manual Operation)
ER	Emergency Relay Coil
ERx	Emergency Relay Contact (x = contact number)
ERA	Emergency Auxiliary Relay Coil
ERAx	Emergency Auxiliary Relay Contact (x = Contact Number)
ERTM	Generator Run Time Meter
EST	Emergency Shunt Trip
ESx	Emergency Auxiliary Switch (x = contact number)
ET1	Emergency Transformer (Line Voltage to 120vac - 2 windings)
ET2	Emergency Transformer (120 to 24vac CT)
ET3	Emergency Transformer (Line Voltage to 12vac)
ET4	Emergency Transformer (Line Voltage to 12vac)
FPSS	Four Position Selector Switch (Option 7)
FR	Frequency Meter
Fx	Fuse (x = Fuse Number)
KF	Failsafe Relay
KV	Voting Relay
MSS	Maintenance Selector Switch
NASx	Normal Lockout (x = contact number)
Nx	Power Terminal, Normal (x = Terminal number)
NL	Normal Position Indicator Light
NLS	Normal Limit Switch
NMPB	Normal Pushbutton for Manual Operation
NR	Normal Relay Coil
NRx	Normal Relay Contact (x = contact number)
NRA	Normal Auxiliary Relay Coil
NRAx	Normal Auxiliary Relay Contact (x = contact number)
NST	Normal Shunt Trip
NSx	Normal Auxiliary Switch (x = contact number)
NT1	Normal Transformer (Line Voltage to 120vac - 2 windings)
NT2	Normal Transformer (120 to 24vac CT)
NT3	Normal Transformer (Line Voltage to 12vac)
NT4	Normal Transformer (Line Voltage to 12vac)
Px-y	Plug (x = number, y = Terminal number)
PBEN	Bypass TDEN Pushbutton
PENE	Bypass TDNE Pushbutton
PBRE	Pushbutton Reset Emergency Trip
PBRN	Reset Normal Breaker Trip Pushbutton
PE	Plant Exerciser
PSDR	Pre-Transfer Signal Device Relay
PSDT	Pre-Transfer Signal Device Timer
PSS	Preferred Source Selector Switch
Sx-y	Socket (x = number, y = Terminal number)
SDL	Service Disconnect Light
SDSS	Service Disconnect Selector Switch
SE	Emergency Source Available Indicator Light
SN	Normal Source Available Indicator Light
Tx	Power Terminal, Load (x = Terminal Number)
TDCL	Time Delay Crank Time Limiter
TDEC	Time Delay Engine Cool Down
TDEN	Time Delay Emergency to Normal
TDES	Time Delay Engine Start
TDNC	Time Delay Neutral
TDNE	Time Delay Normal to Emergency
TE	Emergency Trip Indicator Light
TM	Transfer Motor and Brake
TN	Normal Trip Indicator Light
TPB	Test Pushbutton
TSS	Test Selector Switch
VM	Voltmeter