

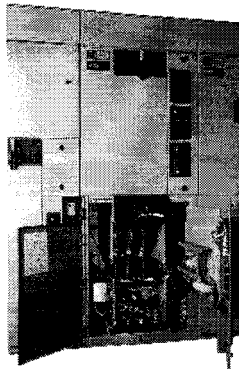

New Information
Supersedes RPD8855V
(August 1994)

AMPGARD® MV Motor Control Vacuum Break SJ Series



400 Amp Starters

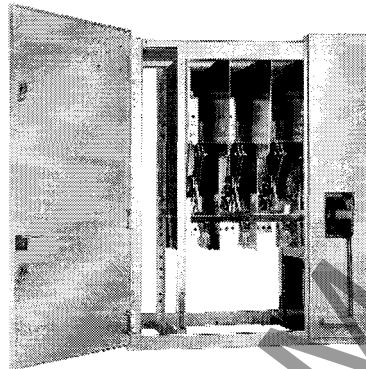

ADM Switches

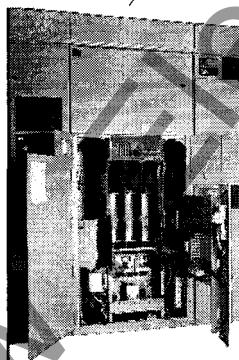
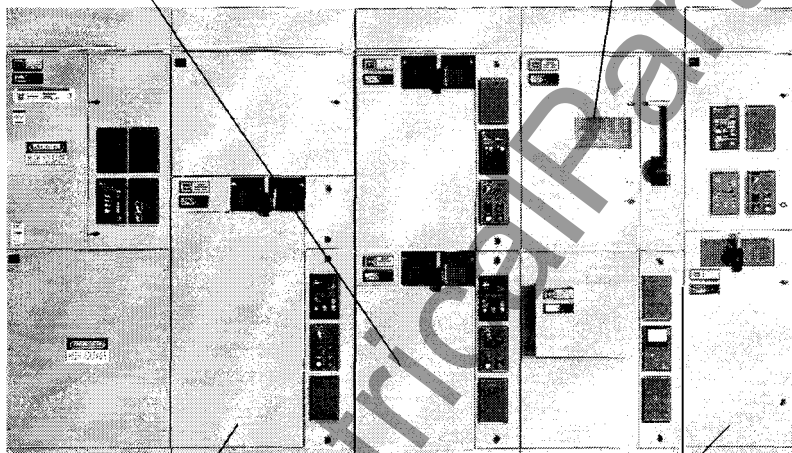

800 Amp Starters



400 Amp Narrow design

Contents	Pages
General Information	2, 3
400-Amp Contactor Design	4-12
(incl. SJA SJS SJD)	
800-Amp Contactor Design	13-16
400 & 800-Amp Common	17-19
Components	
Isolating Switches	20-23
ADM Switch	24-26
MBA (Main Breaker Ampgard)	27
Solid State Reduced Voltage	28-30
Assembly Structure Parts	31-34
Accessories	35
Recommended Spare Parts	36, 37
for Stock	

General Information

Renewal and Replacement Parts

The present design of Ampgard medium voltage starters was introduced in 1962. Additional ratings and features have been continuously introduced over the years.

This renewal parts data will provide the proper identification of standard parts which may be required for the maintenance of Cutler-Hammer Ampgard starters. NOTE: Eaton/Cutler-Hammer acquired the Westinghouse Ampgard Product Line in 1994. Style numbers identified in this brochure may not be the same as style numbers on the original equipment. The renewal part styles in this brochure are in a kit form and may include subassembly, carton, installation instructions, etc. All of the parts shown in the kits are compatible with the SJ vacuum design from 1982 to the present (or noted otherwise).

For equipment other than 60 Hz, refer to factory for information.

Price and availability of parts not listed may be obtained by contacting your local Cutler-Hammer representative. Provide a complete description of the part, along with the complete data on the starter nameplate which is found in the low-voltage area. Be sure to include: ratings, shop order, and diagram reference.

Ordering Instructions

- (1) Specify by **style number**.
- (2) Refer to Price List/Style Number Index 8855 for pricing information, or Vista.

Procedure for Identifying Renewal Parts

Determine the design of the contactor from the catalog number stamped on the starter nameplate (see pg. 3 for breakdown of catalog no.)

OR

- (1) Determine the ampere rating of your starter by measuring the width of the structure.
- (2) Determine if it is non-reversing or reversing by measuring the height of the starter cubicle portion of the Ampgard structure.

Examples:

36 in. width is 400-ampere rated.
Roll-Out design is contactor with wheels. **Slide-Out** design is contactor without wheels.
 45 in. height is non-reversing starter.
 75 in. height is reversing starter.
 Refer to pages 4, 6-12, 17-19 for **Roll-Out** design.
 Refer to pages 5, 6-12, 17-19 for **Slide-Out** design.

40 in. width is 800-ampere rated.
 60 in. Height is non-reversing starter.
 90 in. height is reversing starter.
 Refer to pages 13-16, 17-19.

- (3) Determine the volt amp rating of the control transformer by measuring the height of the control transformer.
- (4) Determine primary voltage: 2300, 4160, etc. This information is on the starter nameplate in the low-voltage area.
- (5) Now that you have identified the design of your complete contactor determine from the photographs which parts are required and identify them by style number.

Obsolete Ampgard Designs

Obsolete Ampgard design starters manufactured prior to 1966 were designated **AMI** starters and were built in various cities in the USA. These starters were "1 High" design,

30 in., 34 in., or 38 in. wide, 100 in. high, and either 30 in. or 60 in. deep. Retrofitting an **AMI** starter is possible with the up-to-date Ampgard components. Refer to 26-000 YES Catalog or refer to factory for information.

Contactors designated type H130, H230, H430 (air), and contactors designated K430 (oil) were utilized in the **AMI** starters. These contactors are obsolete. Refer to factory for information.

Type LF66V430 vacuum contactors shipped prior to 1982 are obsolete and no longer available. For replacement, order up-to-date roll-out design vacuum contactor from page 6 which is mechanically and electronically interchangeable with obsolete Type LF66V430 contactor.

Additional Service

Should you experience difficulty in determining needed parts for repair or determining existing starter condition, contact your local Cutler-Hammer representative. Cutler-Hammer can provide qualified technical personnel on-site to:

- Identify and recommend replacement parts for damage caused by short circuit or fault.
- Remove damaged parts and install replacements.
- Retrofit vintage motor-starting equipment with new components.
- Evaluate condition of existing equipment.
- Test Components.
- Provide a recommended spare parts list.
- Upgrade existing unit from one Hp to another or change operating voltage of existing equipment.
- Convert the starter from air break to vacuum break contactor.

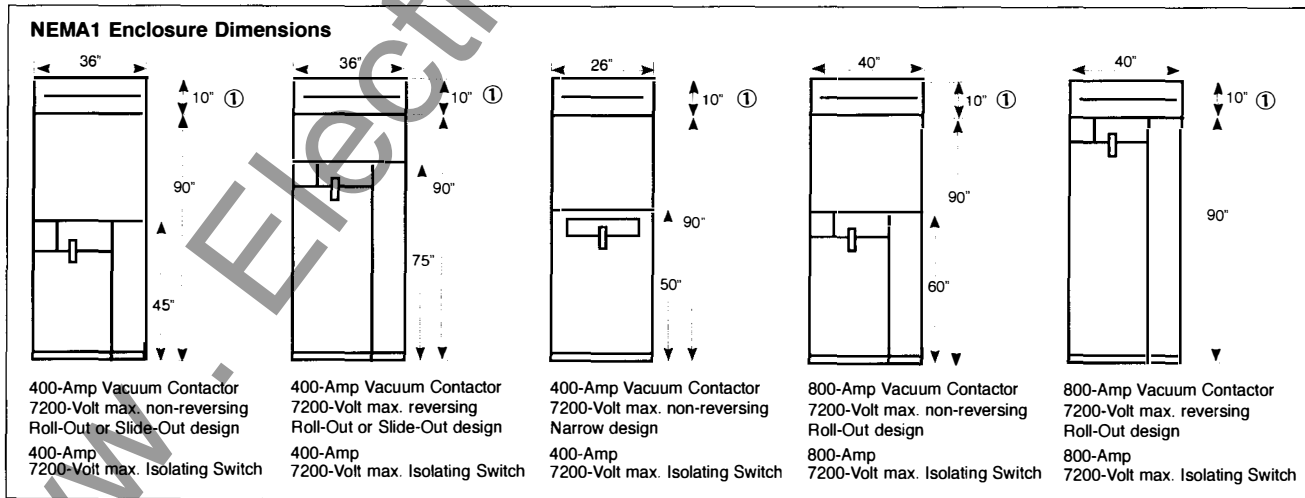

① Main bus enclosure.

Contact Catalog Numbering System Prior to 1985

25 L 2	LF 25 H430
25 - 2500 V	LF - Air Break
33 - 3300 V	SJ - Vacuum
50 - 5000 V	
72 - 7200 V	25 - 2500 V
L - Air Break	33 - 3300 V
V - Vacuum	50 - 5000 V
J - Vacuum	72 - 7200 V
2 - 200A	H - Air Break
4 - 400A	V - Vacuum
7 - 700A	J - Vacuum
8 - 800A	
	2 - 200A
	4 - 400A
	7 - 700A
	8 - 800A
	Normally Open Poles
	Normally Closed Poles

Old Catalog System - Starters (with Isolating Switch, Power Fuses, Contactor, etc.)

10 - Manual	11 - 202 - 25 L 2	2 - 200 A
11 - Magnetic		4 - 400 A
13 - Wound Rotor		7 - 700 A
14 - Synchronous		8 - 800 A
17 - Air Conditioning		L - Air Break
		V - Vacuum
		J - Vacuum
2 - Full Voltage		25 - 2500 V
3 - Solid State		33 - 3300 V
4 - Resistor		50 - 5000 V
5 - Reactor		72 - 7200 V
6 - R.V. Auto-transformer		2 - Non-Load Break, Fused Switch
7 - R.V. Part Winding		1 - Non-Load Break, Non-Fused Switch
8 - R.V. Wye-Delta		
9 - F.V. Multispeed		
0 - Non-Reversing		
1 - Reversing		

Starter Catalog System * 1985 to 1997

H202S4G

H - Air Break	Voltage Class	Vacuum Break	Normally Closed Poles
V - Vacuum Break "Drawout"	E - 2400 V	A - Drawout Usage	
S - Vacuum Break "Slideout"	G - 4160 V	O - OEM Design	Normally Open Poles
		S - Slideout	
Type of Starter	Contactor Amp Rating	25 - 2500 Volt	
202 - FVNR	2 - 200 Amp	50 - 5000 Volt	4 - 400 Amp
212 - FVR	4 - 400 Amp	72 - 7200 Volt	8 - 800 Amp
502 - Reactor	7 - 700 Amp		
602 - Autotransformer	8 - 800 Amp	Vacuum Break	W - Bottle
702 - Part Winding			M - Metric Bottle
802 - Wye-Delta			
902 - Multispeed			
Enclosure			

*Refer to Price List 8810 for complete catalog system breakdown

Current Starter Catalog Numbering System - Effective Nov. 1997

S210SBE

Position 1 (Contactor Type)	Position 7 (Voltage)
S = 400A Vacuum Slideout	A = 2400VAC 60 Hz
R = 400A Vacuum Rollout	B = 3000VAC 60 Hz
E = 800A Vacuum Rollout	C = 3300VAC 60 Hz
D = 400A Vacuum Narrow Design W/Stabs	D = 3600VAC 60 Hz
Position 2 (Starter Type)	E = 4160VAC 60 Hz
2 = Full Voltage, Non-reversing	F = 4800VAC 60 Hz
3 = Full Voltage, Reversing	G = 5500VAC 60 Hz
4 = Reduced Voltage Solid State Soft Start	H = 6000VAC 60 Hz
5 = Reduced Voltage, Reactor	J = 6300VAC 60 Hz
6 = Reduced Voltage, Autotransformer	K = 6600VAC 60 Hz
7 = Reduced Voltage, Reactor, Reversing	L = 6900/7200VAC 60 Hz
8 = Reduced Voltage, Autotransformer, Reversing	Z = Unknown Voltage
Position 3 (Motor Type)	Position 6 (Enclosure Type)
1 = Induction, Single Speed	A = No Enclosure (NEMA 1 Doors)
2 = Induction, Two Speed, Two Winding	B = Type 1 General Purpose
3 = Induction, Two Speed, One Winding	C = Type 1 with Gasketed Doors
4 = Synchronous	D = Type 2 Drip Shield
6 = Wound Rotor	E = Type 12 Dustight
Position 4 (Synchronous Type)	F = Type 3R Outdoor Non-Walkin
0 = Non-Synchronous	G = Type 3R Outdoor Non-Walkin 72" High
1 = Brush Type Mark V Synchronous	H = Type 3R Outdoor Walkin
3 = Brush Type Synchronous Relay Panel	J = Type 1 Half High (NEMA 1 Only)
4 = Brushless Type Synchronous Relay Panel	K = Type 1 Half High wuth Gasketed Doors
5 = Brushless Type Synchronous Mark V	L = No Enclosure (NEMA 3/12 Doors)
	Position 5 (Disconnect Switch)
	S = Isolation Switch
	A = Mechanical Future W/Cover
	F = Electrical Future W/Cover Plate
	G = Electrical Future W/Isolation Switch
	P = No Isolation Switch, Cover Plate Only

400 Amp, 7200 Volt Max. Roll-Out "SJA" Vacuum Break Contactor

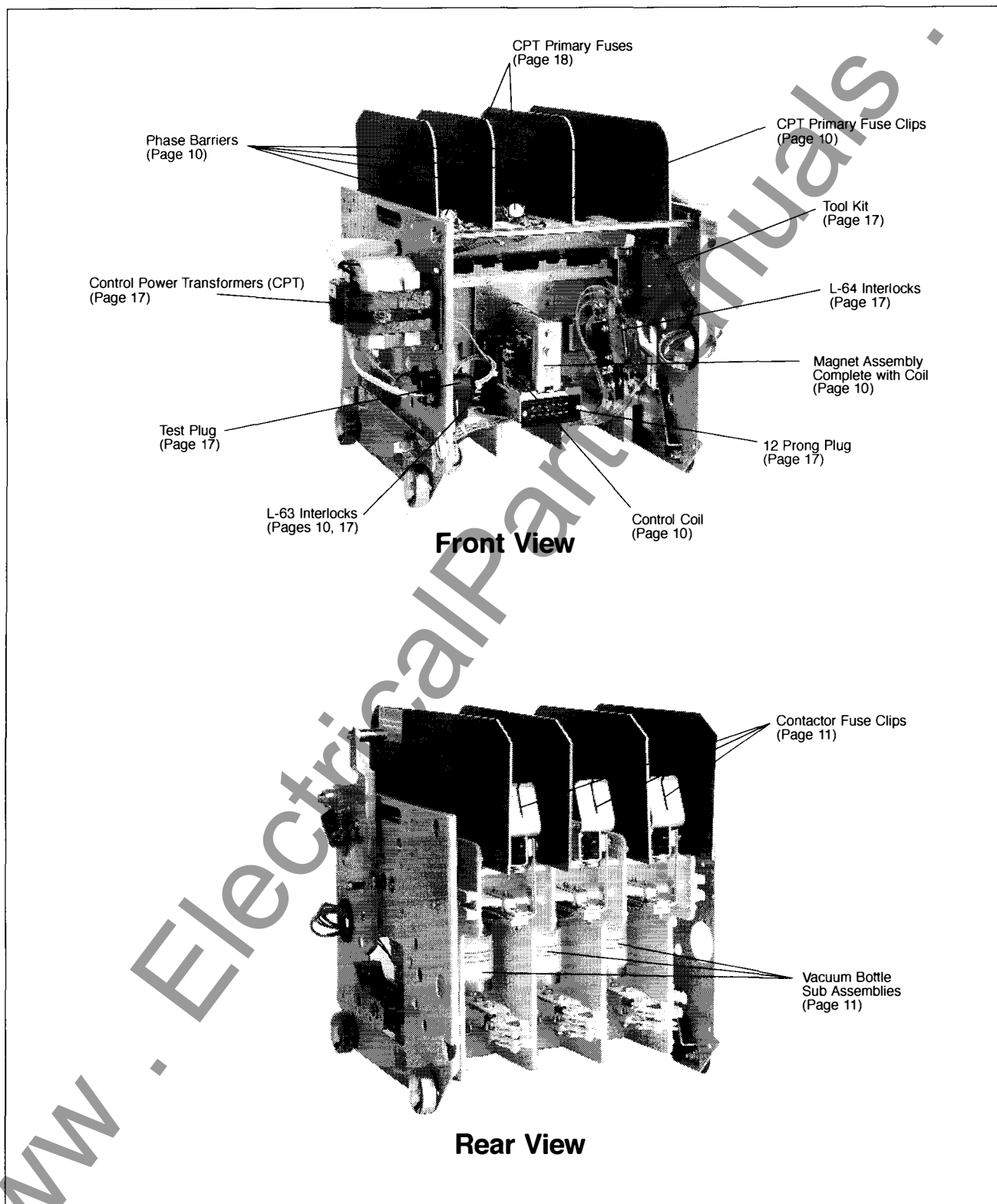

400 Amp, 7200 Volt Max. Slide-Out "SJS" Vacuum Break Contactor

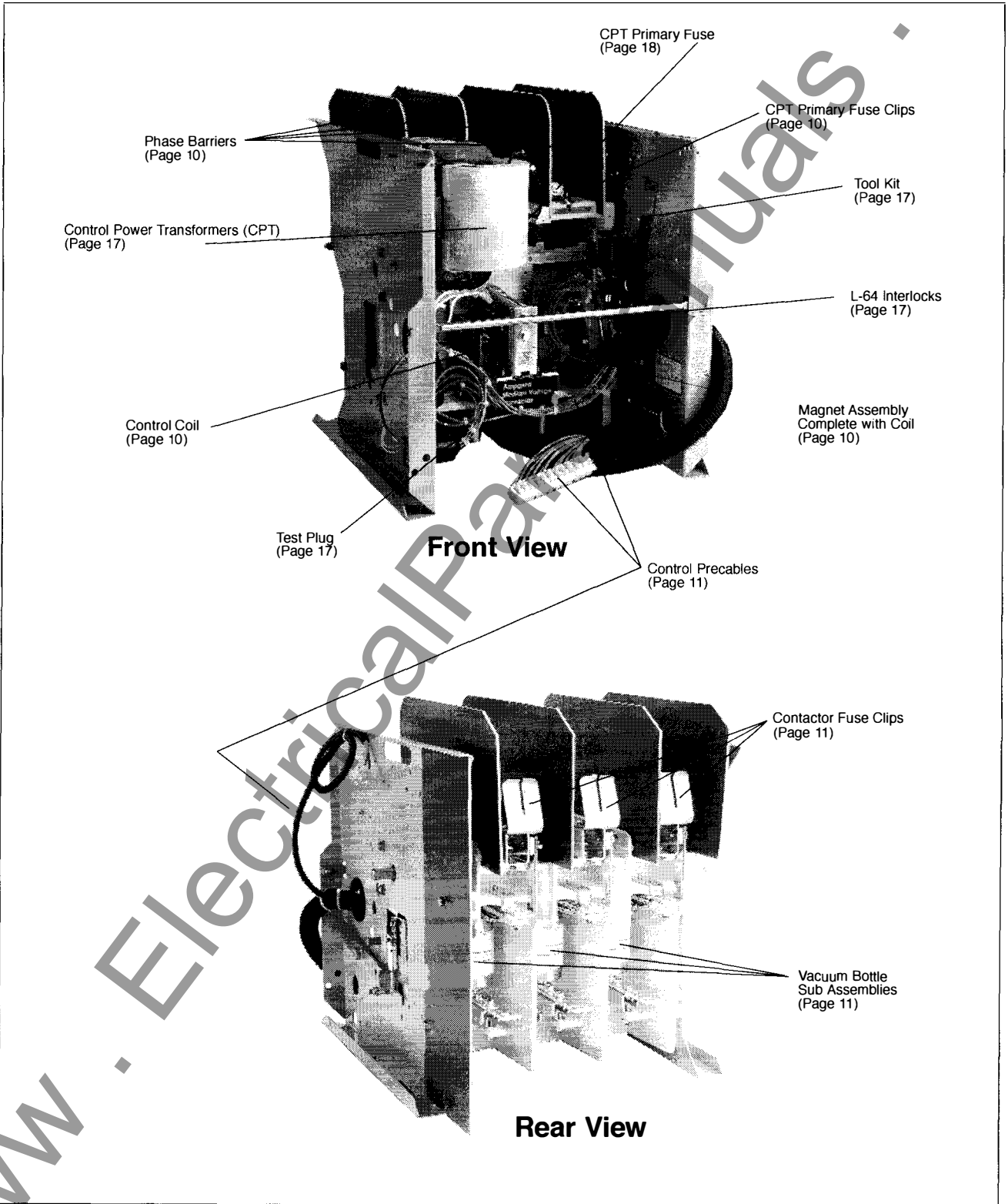

400 Amp, 7200 Volt Max. Vacuum Break Contactor

Contactors with 120-Volt control transformer and two normally open and two normally closed interlocks. To determine proper complete contactor style number, refer to the photograph showing both sizes of control transformers. The smaller control transformer with a height dimension of 5 inches is rated 600-Volt amp at 4160 volts and 750-Volt amp at 2300-volts. The larger control transformers with a height of 7 inches is rated 2KVA at either 2300 or 4160-volts.

Approximate shipping weight 150 lbs. (68kg.)

Roll-Out Design (SJA)

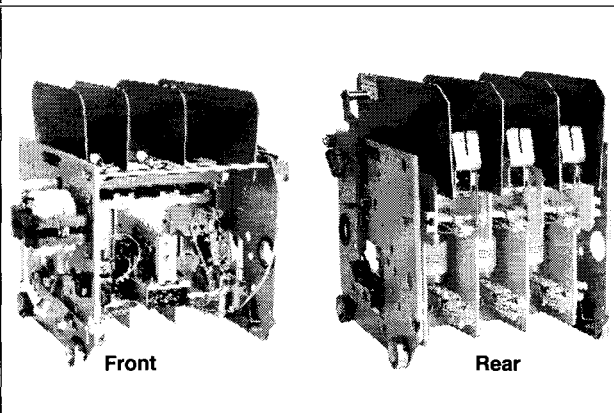

Description *	Style Number
Complete 2300V contactor with 750VA control transformer, 60 Hz	2147A45G01
Complete 2300V contactor with 2KVA control transformer, 60 Hz	2147A45G02
Complete 4160V contactor with 600VA control transformer, 60 Hz	2147A45G03
Complete 4160V Contactor with 2KVA control transformer, 60 Hz	2147A45G04

For contactor with 240-Volt AC control, order similar to style number 2147A45G0_, except 240-Volt AC control.

For SJA contactors supplied after October 1988 with pull-a-part terminal blocks, order SJS precable Style No. 2147A15G_, from page 11 for field mounting.

If main contactor is used in reversing, autotransformer, multi-speed starter, or has potential transformer connection order line fingers Style No. 2147A49G01 from page 10 for field mounting.

If main contactor must be mechanically interlocked with other contactor, order mechanical interlock arm Style No. 2147A43G14 from page 12 for field mounting.

* Rotate interference bar 180 degrees if used with old, narrow flange doors supplied prior to July 1983.

Slide-Out Design (SJS)

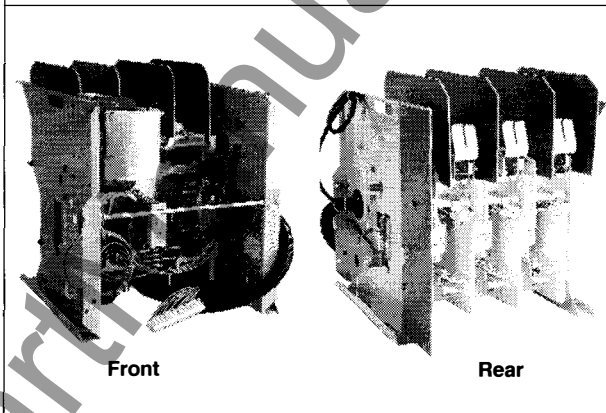

Description	Style Number
Complete 2300V contactor with 750VA control transformer, 60 Hz	2147A45G21
Complete 2300V contactor with 2KVA control transformer, 60 Hz	2147A45G22
Complete 4160V contactor with 600VA control transformer, 60 Hz	2147A45G23
Complete 4160V contactor with 2KVA control transformer, 60 Hz	2147A45G24

For contactor with 240-Volt AC control, order similar to Style No. 2147A45G2_, except 240-Volt AC control.

If main contactor must be interlocked with another contactor, order contactor interlock arms Style No. 2147A43G12 from page 12 for field mounting.

The main contactor may mount line current transformers, ground fault current transformers, control transformer, and 3-phase potential transformer. See pages 17-19 for various style numbers.

400 Amp, 7200 Volt Max. Vacuum Break Contactor

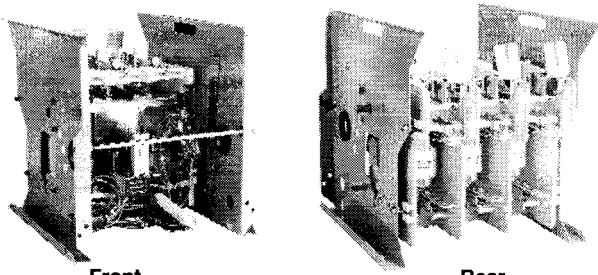
Slide-Out Design (SJS) Base Unit	
<p>Contactors (Basic quick ship) similar to Style No. 2147A45G21, G22, G23, G24, page 6, except without control transformer, with precable, without (4) barriers, without mechanical interlock arm, 120-Volt control.</p> <p>Approximate shipping weight 125 lbs. (57 kg.)</p>	
 <p style="text-align: center;">Front Rear</p>	
Style Number	2147A45G25
<p>For contactor with 240-Volt AC control order similar to 2147A45G25, except 240-Volt AC control.</p>	

Narrow Design (SJD) *	
<p>Contactors, drawout stab connected, 5000 Volt max. to fit the 26" wide narrow design assembly.</p> <p>Approximate shipping weight 155 lbs. (70 kg.)</p>	
 <p style="text-align: center;">Front Rear</p>	
Style Number	2147A45G50
<p>*5000 Volts Max.</p>	

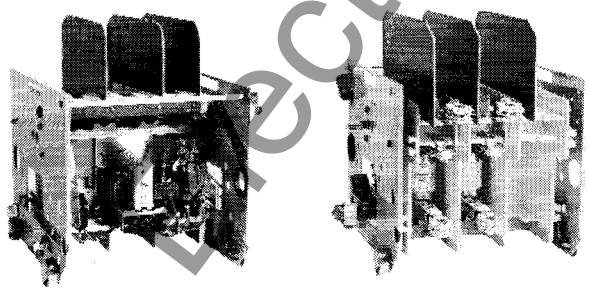
2 Pole Roll-Out Design (SJA)	
<p>Two-pole contactor with line and load fingers, 120-Volt coil (used as shorting and run contactor for a 2 coil autotransformer reduced voltage starter.)</p> <p>Approximate shipping weight 125 lbs. (57 kg.)</p>	
 <p style="text-align: center;">Front Rear</p>	
Style Number	2147A46G06
<p>For contactor with 240-Volt coil order similar to Style No. 2147A46G06 except 240-Volt coil.</p>	

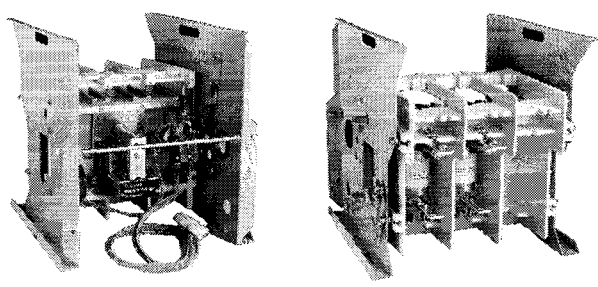
2 Pole Slide-Out Design (SJS)	
<p>Two-pole contactor 120-Volt coil. (Used as starting and run contactor for a 2 coil autotransformer reduced voltage, starter includes mechanical interlock arm for mechanical interlock.)</p> <p>Approximate shipping weight 100 lbs. (45 kg.)</p>	
 <p style="text-align: center;">Front Rear</p>	
Style Number	2147A46G16
<p>For Contactor with 240-Volt coil, order similar to Style No. 2147A46G16 except with 240-Volt coil.</p>	

www.ElectricalPartManuals.com

400 Amp, 7200 Volt Max. Vacuum Break Contactor

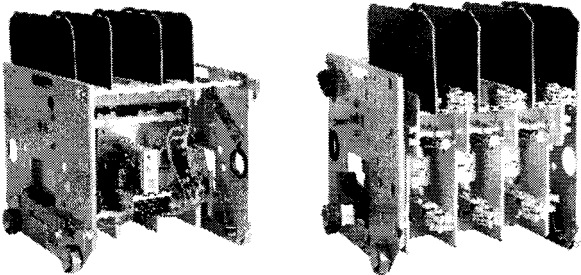
Reversing (3 Pole) Roll-Out (SJA)	
<p>Three-pole reversing contactor with line and load fingers, includes mechanical interlock arm, for mechanical interlock, 120-Volt coil (used as reversing contactor or reactor shorting contactor of a reactor reduced voltage starter.)</p> <p>Approximate shipping weight 150 lbs. (68 kg.)</p>	
 <p style="text-align: center;">Front Rear</p>	
Style Number	2147A46G05
<p>For contactor with 240-Volt coil order similar to Style No. 2147A46G05 except 240-Volt coil.</p>	

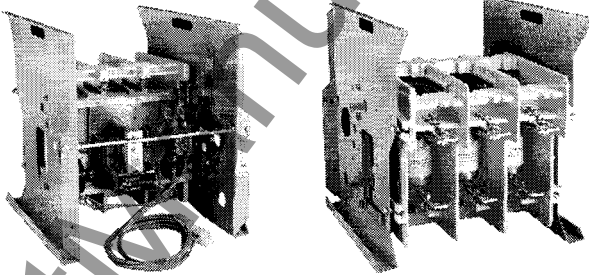
Reversing (3 Pole) Slide-Out Design (SJS)	
<p>Three-pole reversing contactor, includes mechanical interlock arm for mechanical interlock, 120-Volt coil. (Used as reversing contactor or reactor shorting contactor of a reactor voltage starter. Also used as the run contactor of a 3 coil autotransformer starter.)</p> <p>Approximate shipping weight 115 lbs. (52 kg.)</p>	
 <p style="text-align: center;">Front Rear</p>	
Style Number	2147A46G15
<p>For contactor with 240-Volt coil, order similar to Style No. 2147A46G15 except with 240-Volt coil.</p>	

www.ElectricalPartManuals.com

400 Amp, 7200 Volt Max. Vacuum Break Contactor

Latched Roll-Out Design (SJA)

Three-pole latched contactor single trip solenoid, 120-Volt control, with control transformer and two normally open and two normally closed interlocks. To determine proper complete contactor style number, refer to the photograph (page 17) showing both sizes of control transformers. The smaller control transformer with a height dimension of 5 inches is rated 750-Volt amp at 4160-volts. The larger control transformer with a height of 7 inches is rated 2KVA at either 2300 or 4160-volts.

Approximate shipping weight 150 lbs. (68 kg.)

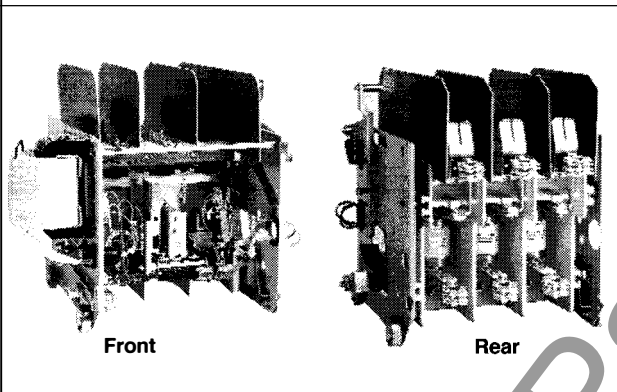

Description	Style Number
Complete latched contactor 2300-Volt, 750-VA transformer, 60 Hz	2147A45G11
Complete latched contactor 2300-Volt, 2KVA transformer, 60Hz	2147A45G12
Complete latched contactor 4160-Volt, 750-VA transformer, 60 Hz	2147A45G13
Completed latched contactor 4160-Volt, 2KVA transformer, 60 Hz	2147A45G14

For contactor with 240-Volt AC control, order similar to Style No. 2147A45G1_, except 240-Volt AC control.

For contactor with 2 trip solenoids order similar to Style No. 2147A45G1_, except specify trip voltage 120 or 240-Volt AC, or intermittent 48, 125, 250 volts DC (any combination or 2 voltages.)

Latched Slide-Out Design (SJS)

Three-pole latched contactor single trip solenoid, 120-Volt control, with control transformer and two normally open and two normally closed interlocks. To determine proper complete contactor style number, refer to the photograph (page 17) showing both sizes of control transformers. The smaller control transformer with a height dimension of 5 inches is rated 750-Volt amp at 4160 volts and 750-Volt amp at 2300-volts. The larger control transformer with a height of 7 inches is rated 2KVA at either 2300 or 4160-volts.

Approximate shipping weight 150 lbs. (68 kg.)

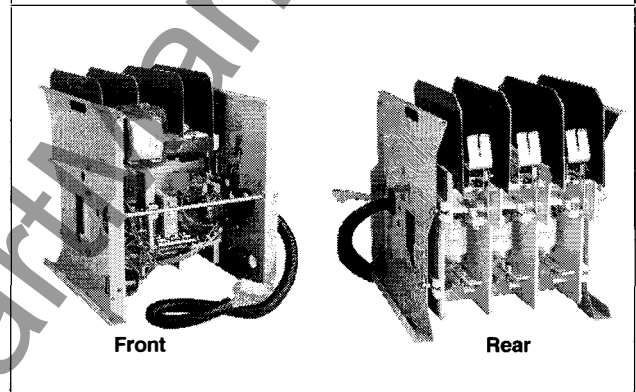

Description	Style Number
Complete latched contactor 2300-Volt, 750-VA transformer	2147A45G31
Complete latched contactor 2300-Volt, 2KVA transformer	2147A45G32
Complete latched contactor 4160-Volt, 750-VA transformer	2147A45G33
Completed latched contactor 4160-Volt, 2KVA transformer	2147A45G34

For contactor with 240-Volt AC control, order similar to Style No. 2147A45G3_, except 240-Volt AC control.

For contactor with 2 trip solenoids order similar to Style No. 2147A45G3_, except specify trip voltage 120 or 240-Volt AC, or intermittent 48, 125, 250 volts DC (any combination or 2 voltages.)

www.ElectricalPartManuals.com

400 Amp, 7200 Volt Max. Vacuum Break Contactor

**L-63 interlock & mounting kit
(L-63 interlock only page 17)**

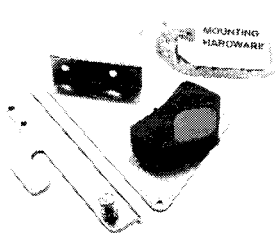

Type	Style Number
SJA, SJS, SJD	2147A48G30

**Phase barriers, main & reversing
contactor, Qty.4**

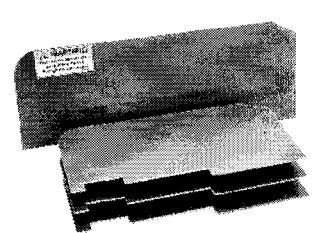

Type	Style Number
SJA, SJD	2147A47G11

**Fuse clips & mounting for primary
fuses of control transformer or
potential transformer, Qty.3**



Type	Style Number
SJA, SJS, SJD	2147A47G16

Contactor Coil

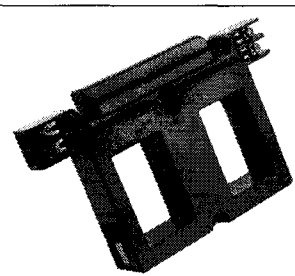

Type	Voltage	Style Number
SJA	120	2147A48G11
SJS	240	2147A48G21

**Phase barriers, main
contactor, Qty.4**

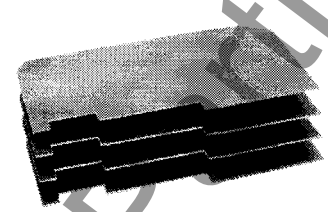

Type	Style Number
SJS	2147A47G14

**Contactor line or load fingers,
without support, Qty.3**

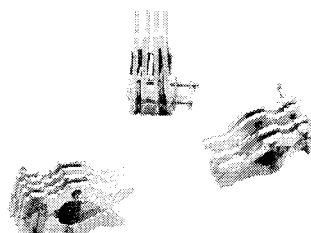

Type	Style Number
SJA, SJD	2147A47G23

**Magnet assembly complete
with coil**

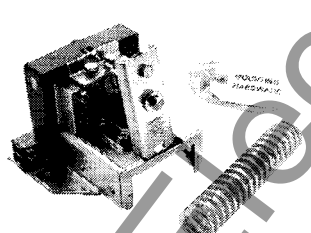

Type	Voltage	Style Number
SJA	120	2147A48G12
SJS	240	2147A48G13
SJD	*	2147A48G14

* without coil

**Line fingers with copper
support, Qty.3**
Required as a field modification to a main
contactor to supply power to potential
transformers and to reversing contactors.

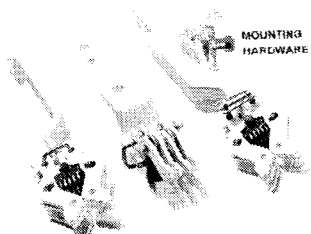

Type	Style Number
SJA, SJD	2147A49G01

www.ElectricalPartManuals.com

400 Amp, 7200 Volt Max. Vacuum Break Contactor

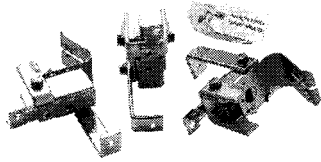
Contactor Fuse Clips, Qty.3	
	
Type	Style Number
SJA, SJS, SJD	2147A49G11

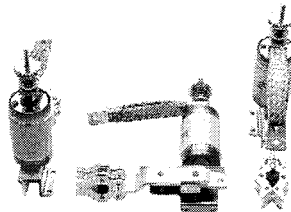
Vacuum bottle subassemblies with shunt and load support and load fingers, Qty. 3	
	
Type	Style Number
SJA, SJD	2147A47G03

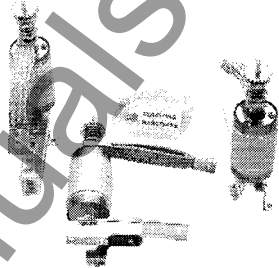
Vacuum bottle subassemblies with shunt and load support, Qty. 3	
	
Type	Style Number
SJS	2147A47G13

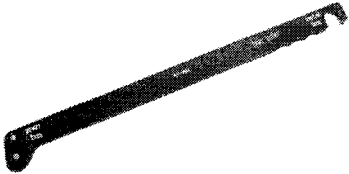
Fuse Puller	
	
Type	Style Number
SJA, SJS, SJD	2147A93G04

Contactor Control Precables		
		
Type	Description	Style Number
SJS	With pull-apart terminal blocks	2147A15G10
	12 point precable only (part of 2147A15G10), for coil and interlock circuitry	2147A15G17

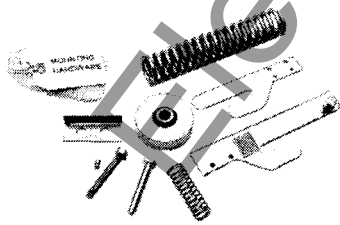
Misc. parts kit- Kickout spring and adjusting bolt, coil clip, set screw, electrical interlock operating arms with mounting hardware, mechanical interlock spring and contactor wheel	
	
Type	Style Number
SJA, SJS, SJD	2147A48G15

www.ElectricalPartManuals.com

400 Amp, 7200 Volt Max. Vacuum Break Contactor

Contactor mechanical interlock arms for interlock between isolating switch or any reversing or reduced voltage or multispeed contactor

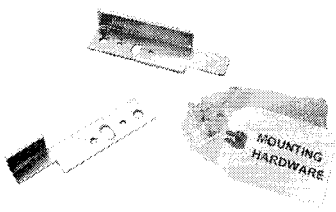

Type	Style Number
SJS	2147A43G12

Mechanical interlock arm for field mounting on contactor

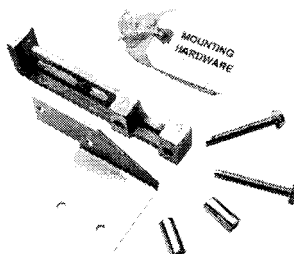

Type	Style Number
SJA	2147A43G14

Mechanical interlock kit between isolating switch and main contactor or between (2) contactors (autotransformer, reversing, multi-speed application)

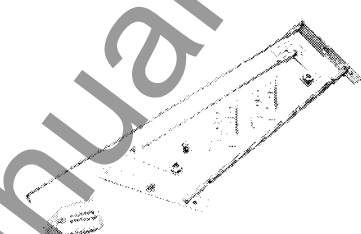

Type	Style Number
SJS	2147A43G13

Replacement mechanical latch kit (single trip solenoid) with L-64 interlock

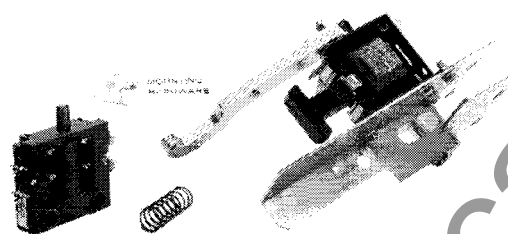

Type	Description	Style Number
SJA	120V AC continuous/48V DC intermittent	2147A48G22
SJS	230V AC continuous/96-125V DC intermittent	2147A48G23
SJD		

Double solenoid latch attachments are also available. Specify similar to Style No. 2147A48G_ above except with double solenoid latch. Also specify operating voltage for each trip coil.

Replacement mechanical latch kit (single trip solenoid) with one L-63 & two L-64 interlocks

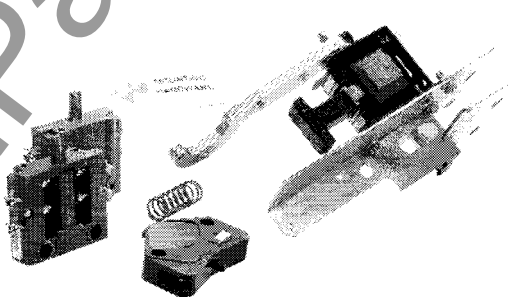

Type	Description	Style Number
SJA	With contactor mounted 12 point receptacle & 115V AC coil	2147A48G29
SJS*		

*discard 12 point receptacle & precable

For mechanical latch kit with dual trip solenoid order similar to Style No. 2147A48G29 except dual solenoid for operation at ___ volts. Specify trip voltage, 120 or 240-Volt AC, or intermittent 48, 125, 250 volts Dc.

Description	AC	DC(Int.)	Style Number
Single solenoid assembly only without magnet assembly, interlocks, 12 point receptacle & precable.	115V	48V	5264C05H01
	230V	96-125V	5264C05H02
	460V	250V	5264C05H03
	575V	-----	5264C05H04
	-----	24V	5264C05H05

www.ElectricalPartManuals.com

800 Amp, 7200 Volt Max. Roll-Out "SJA" Vacuum Break Contactor

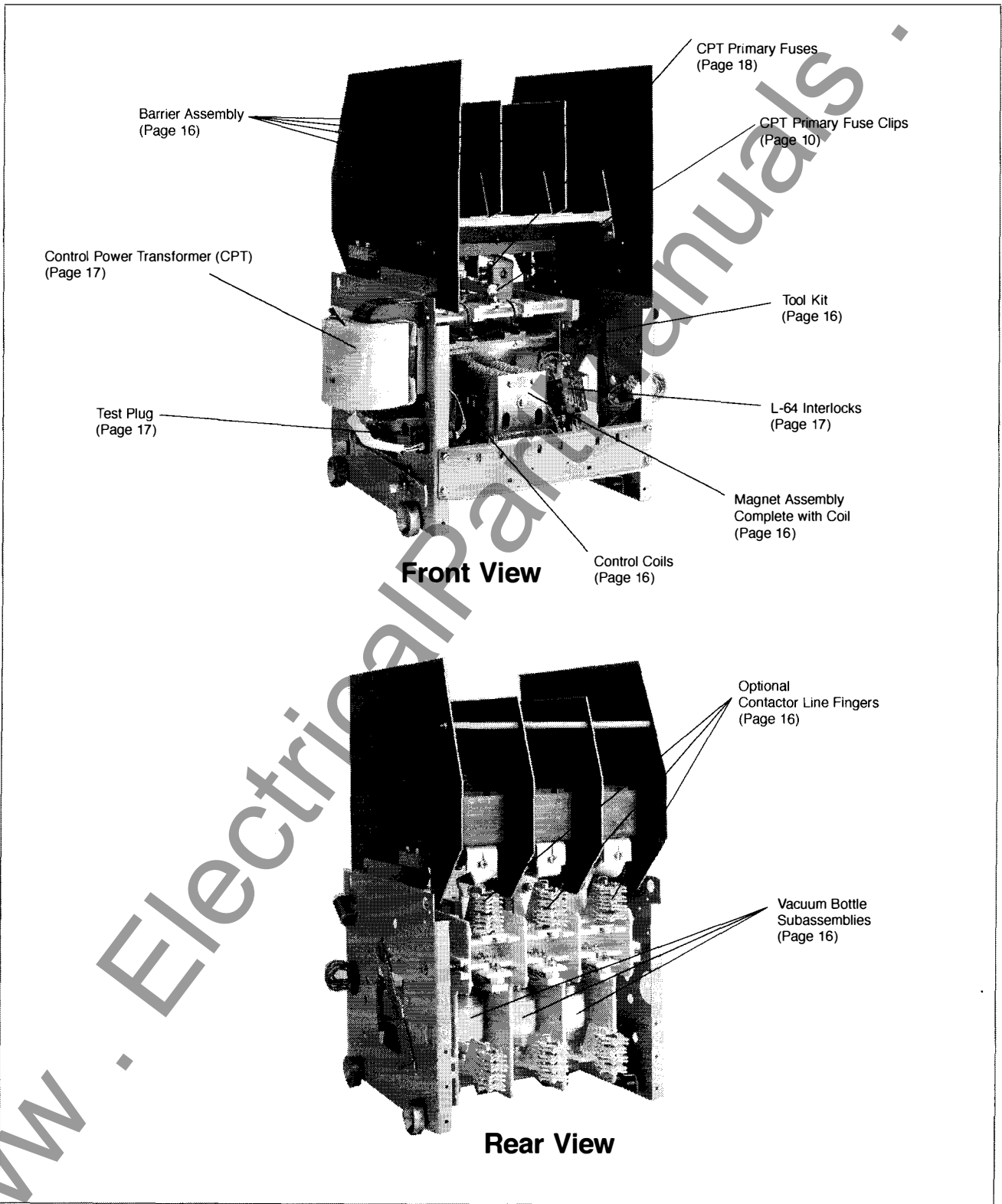

www.ElectricalPartManuals.com

800 Amp, 7200 Volt Max. Roll-Out "SJA" Vacuum Break Contactor

Contactor 120-Volt control, with control transformer and two normally open and two normally closed interlocks, 2KVA control transformer

Approximate shipping weight 175 lbs. (79 kg.)

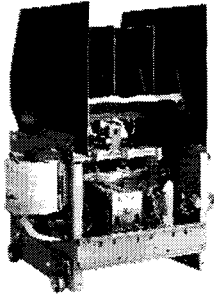

Front

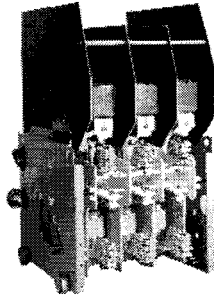

Rear

Description	Style Number
Complete contactor, 2300/120-Volt, 2KVA transformer, 60 Hz	2147A85G01
Complete contactor, 4160/120-Volt, 2KVA transformer, 60 Hz	2147A85G02

For contactor with 240-Volt AC control, order similar to Style No. 2147A85G0_ except 240-Volt AC control.

For SJA contactors supplied after October 1988 with pull-a-part terminal blocks, order SJS precable Style No. 2147A15G_ from page 11 for field mounting.

If main contactor is used in reversing, autotransformer, multi-speed starter, or has potential transformer connection refer to page 16 and order line fingers Style No. 2147A89G01.

Three-pole reversing contactor with line and load fingers, includes mechanical interlock arm for mechanical interlock, (used as reversing contactor or reactor shorting contactor of a reactor reduced voltage starter.)

Approximate shipping weight 160 lbs. (73 kg.)

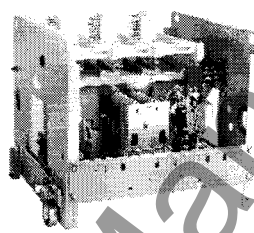

Front

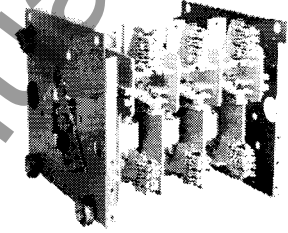

Rear

Description	Style Number
Complete contactor with 120-Volt coil	2147A86G12
For contactor with 240-Volt coil order similar to Style No. 2147A86G12 except with 240-Volt coil.	

www.ElectricalPartManuals.com

800 Amp, 7200 Volt Max. Roll-Out "SJA" Vacuum Break Contactor

Two-pole contactor with line and load fingers, (used as starting and run contactor for an autotransformer reduced voltage starter) includes mechanical interlock arm.

Approximate shipping weight 145 lbs. (66 kg.)

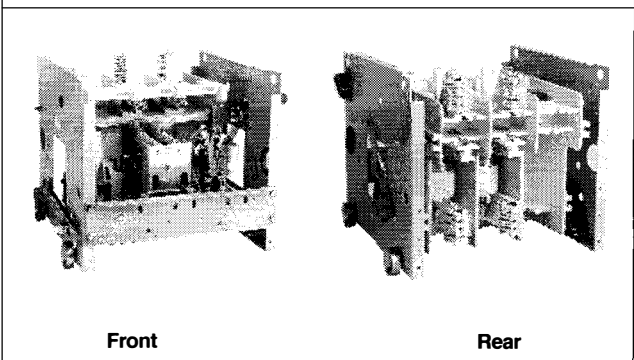

Description	Style Number
Complete contactor with 120-Volt coil.	2147A86G06
For contactor with 240-Volt coil, order similar to Style No. 2147A86G06 except with 240-Volt coil.	
Double solenoid latch attachments are also available. Specify similar to Style No. 2147A88G_ above except with double solenoid latch. Also specify operating voltage for each trip coil.	

Three-pole latched contactor, single trip solenoid 120-Volt control, with control transformer and two normally open and two normally closed interlocks, 2KVA control transformer.

Approximate shipping weight 180 lbs. (82 kg.)

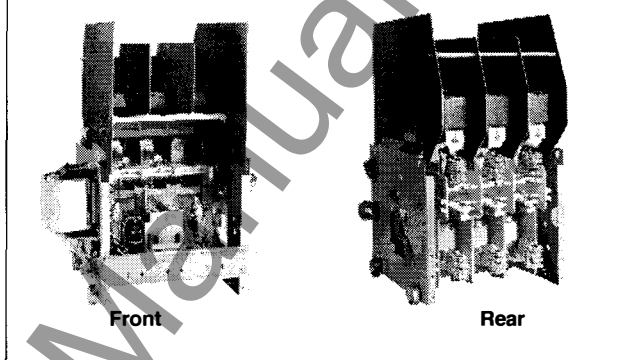

Description	Style Number
Complete latched contactor 2300/120-Volt, 2KVA transformer, 60 Hz	2147A85G11
Complete latched contactor 4160/120-Volt, 2 KVA transformer, 60 Hz	2147A85G12
For contactor with 240-Volt AC control, order similar to Style No. 2147A85G1_ , except 240-Volt AC control.	
For contactor with 2 trip solenoids order similar to Style No. 2147A85G1_ , except specify trip voltage 120- or 240-Volt AC, or intermittent 48, 125, 250 volts DC (any combination of 2 voltages)	

Description	AC	DC(Int.)	Style Number
Single solenoid assembly only without interlocks, precable, or magnet parts.	115V	48V	5259C73H01
	230V	96-125V	5259C73H02
	460V	250V	5259C73H03
	575V	-----	5259C73H04
	-----	24V	5259C73H05

Replacement mechanical latch kit with one trip solenoid and one L-64 interlock

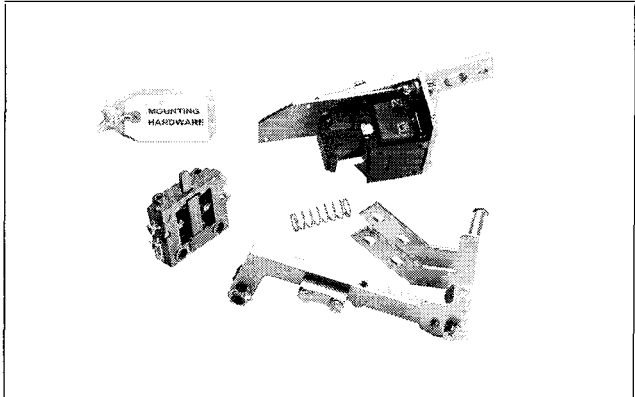

Volts	Style Number
120V AC continuous - 48V DC intermittent	2147A88G22
230V AC continuous - 125V DC intermittent	2147A88G23

www.ElectricalPartManuals.com

800 Amp, 7200 Volt Max. Roll-Out "SJA" Vacuum Break Contactor

Barrier Assembly

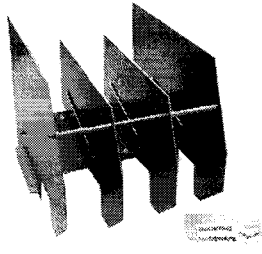

Style Number 2147A89G07

Fuse support & barrier assembly

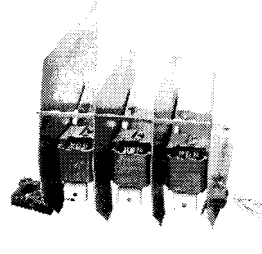

Style Number 2147A89G06

Fuse load fingers (connection between contactor & fuse), Qty. 3

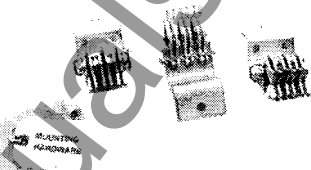

Style Number 2147A71G15

Contactor Coil, Qty. 2

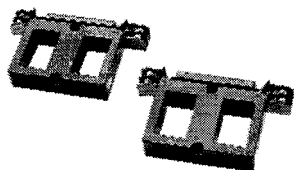

Volts	Style Number
120 AC	214A88G11
240 AC	214A88G12

Magnet assembly complete with coil

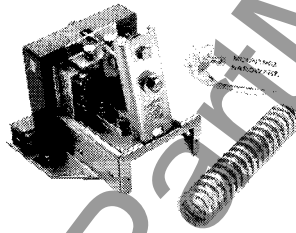

Volts	Style Number
120 AC	2147A88G02
240 AC	2147A88G03
without coil	2147A88G04

Contactor line fingers with copper support, Qty. 3
Required as a field modification to a main contactor to supply power to potential transformers and to reversing contactors.

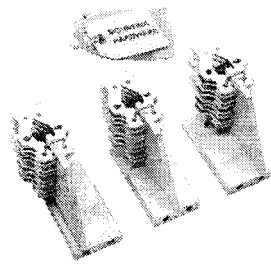

Style Number 2147A89G01

Vacuum bottle subassemblies with shunt, load support, & load fingers, Qty. 3



Style Number 2147A87G03

Misc. Parts Kit- Kickout springs and adjusting bolt, coil clip, electrical interlock operating arm with mounting hardware, mechanical interlock spring, and wheel

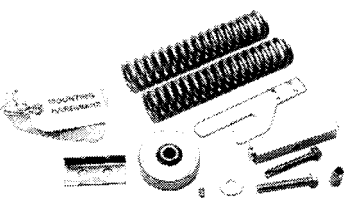

Style Number 2147A88G15

Contactor line or load fingers without support, Qty.3

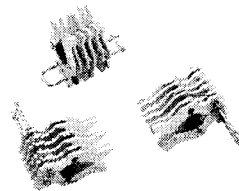

Style Number 2147A89G02

Fuse Puller

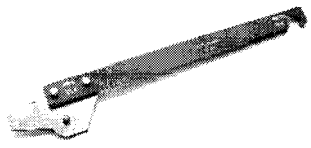

Style Number 2147A93G07

www.ElectricalPartManuals.com

400 & 800 Amp, 7200 Volt Max. Vacuum Break Contactors Common Components

L-63 interlock (coil circuit)

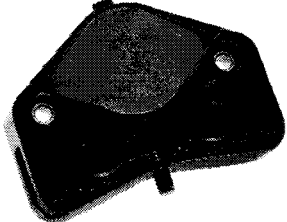

Style Number 578D461G03

Contactor mounted run-test circuit 15 Amp plug (use standard NEC fuse) (fuse block only see below)

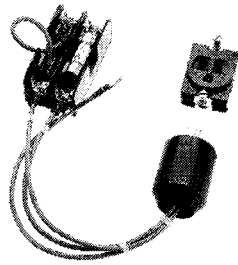

Style Number 2147A15G09

Standard control transformer, 60 Hz

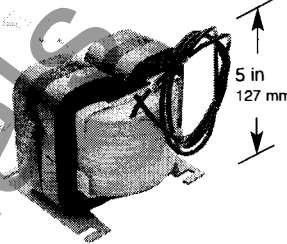

5 in
127 mm

Rating	Style Number
2300/120V 750VA	2147A11G01
2300/240V 750VA	2147A11G03
4160/120V 750VA	2147A11G05
4160/240V 750VA	2147A11G07

L-64 auxiliary interlocks

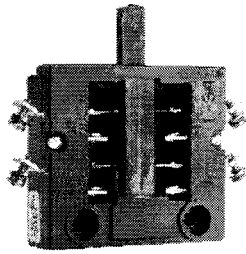

Contacts	Style Number
1 NO INC	843D943G21
2 NO	843D943G22
2 NC	843D943G23

Fuse block with fuse clips for control circuit

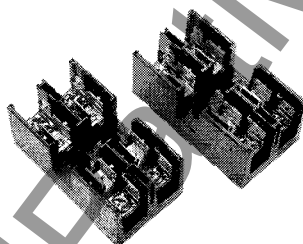

Type	Qty.	Style Number
2 pole	2	2147A12G16
1 pole	4	2147A15G15

2KVA control transformer, 60 Hz

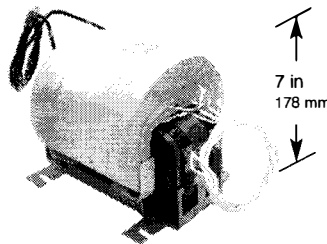

7 in
178 mm

Rating	Style Number
2300/240/120V	2147A11G02
4160/240/120V	2147A11G06

Tools - Feeler gauge and bottle wrench

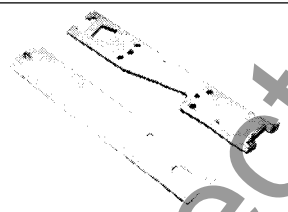

Style Number 2147A47G15

Fuses, dual element miniature type, 500-Volt 1 1/2 in. long, 13/32 in. dia. for use with Style No. 2147A15G15 or G16

1 Amp Qty. 5
10 Amp Qty. 5
15 Amp Qty. 5

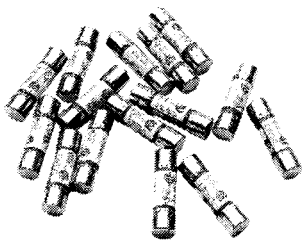

Style Number 2147A11G42

12 prong plug with wire



Style Number 2147A15G04

Primary fuse bands, Qty. 3



Style Number 2147A11G31

www.ElectricalPartManuals.com

400 & 800 Amp, 7200 Volt Max. Vacuum Break Contactor Common Components

5000V fuse blocks with 1 in. dia. fuse clips for primary fuses for control transformers

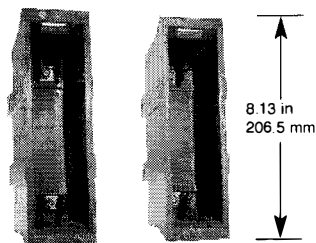

Kit Quantity	Style Number
2	2147A11G22
3	2147A11G45

5000V control transformer primary fuses for use with above fuse blocks & fuse clips on page 10

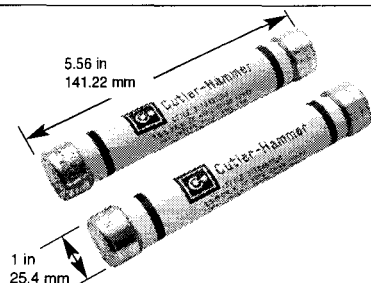

Rating	Kit Qty.	Style Number
1A	2	2147A11G62
5KV*	3	2147A11G63
3A	2	2147A11G25
5KV*	3	2147A11G46
5A	2	2147A11G52
5KV*	3	2147A11G53

* For above 5KV contact Asheville

Current transformers single phase donut type, Qty.3

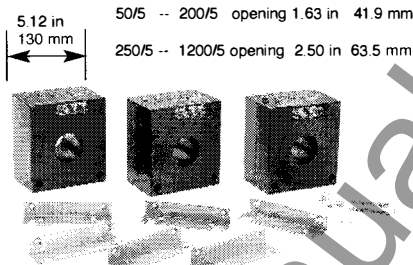

Ratio	Style Number
50/5	Note 1
75/5	Note 2
100/5	2147A13G04
150/5	2147A13G05
200/5	2147A13G06
250/5	2147A13G07
300/5	2147A13G08
400/5	2147A13G09
500/5	2147A13G10
600/5	2147A13G11
750/5	2147A13G12
800/5	2147A13G13
1000/5	2147A13G14
1200/5	2147A13G15

Note 1-Use Style No. 2147A13G04 and double loop primary leads.
Note 2-Use Style No. 2147A13G05 and double loop primary leads.

Current transformers three phase donut type

50/5 - 400/5 opening 1.75 in dia. 44.5mm in dia.
500/5 - 1200/5 opening 2.00 in dia. 50.8 mm in dia.

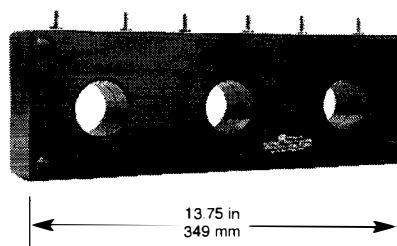

Ratio	Style Number
50/5	Note 3
75/5	Note 4
100/5	2147A16G04
150/5	2147A16G05
200/5	2147A16G06
300/5	2147A16G08
400/5	2147A16G09
500/5	2147A16G10
600/5	2147A16G11
800/5	2147A16G13
1000/5	2147A16G14
1200/5	2147A16G15

Note 3 Use Style No. 2147A16G04 and double loop primary leads.
Note 4 Use Style No. 2147A16G05 and double loop primary leads.

www.ElectricalPartManuals.com

Common Components 400 & 800 Amp, 7200 Volt Max. Vacuum Break Contactor

**Potential transformers 450VA single phase, Qty.2
60 Hz**



Rating	Style Number
2400/120V	2147A11G11
4200/120V	2147A11G12

Potential transformer 100VA, 3 phase open delta. with primary fuse provision, 60 Hz

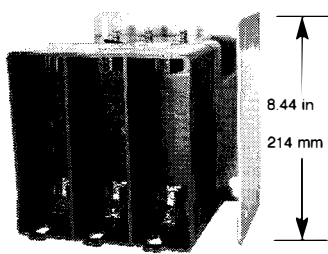

Rating	Style Number
2400/120V	2147A11G14
4200/120V	2147A11G15

Potential transformer 100VA 3 phase, 60 Hz, open delta, without primary fuse provision

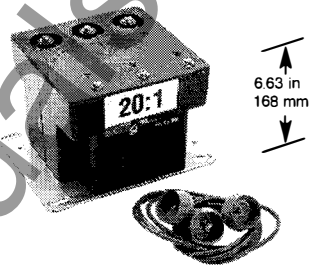

Rating	Style Number
2400/120V	2147A11G36
3300/120V	2147A11G37
4200/120V	2147A11G38
4800/120V	2147A11G39

Ground fault current transformer, 50/5 ratio for use with IQ 1000, IQ 2000 relays

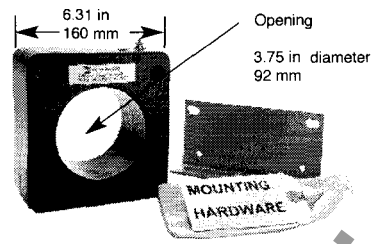

6.31 in
160 mm

Opening
3.75 in diameter
92 mm

MOUNTING
HARDWARE

Style Number	2147A11G47
--------------	------------

Type G Overload heaters



Secondary Current Transformer Range 3-Pole Rating	Heater Rating	Style Number
1.96-2.15	2.44	506C578G24
2.16-2.35	2.69	506C578G25
2.36-2.58	2.95	506C578G26
2.59-2.83	3.23	506C578G27
2.84-3.11	3.55	506C578G28
3.12-3.42	3.90	506C578G29
3.43-3.73	4.28	506C578G30
3.74-4.07	4.67	506C578G31
4.08-4.39	5.1	506C578G32

Order Entry Note: Heaters are priced as each heater.
Heaters must be ordered in multiples of 3.

The type G overload heaters for the Type A overload relay are for use on AMPGARD starters only. These heaters are coordinated with power fuses and current transformers for each order. Do not change heater, power fuse, or current transformer before consulting factory.

Note that prior to 5/66 the standard overload for the AMPGARD was the Type MG overload, which is no longer available. Also note that the Type A 2-pole overload was standard from 6/66 to 7/73. For conversion to up-to-date overload with 3-phase protection consult factory.

www.ElectricalPartManuals.com

Isolating Switch, 400 Amp, 7200 Volt, Slide-Out (Type 72LFS-4) & Roll-Out (Type 72LFR-4) Design

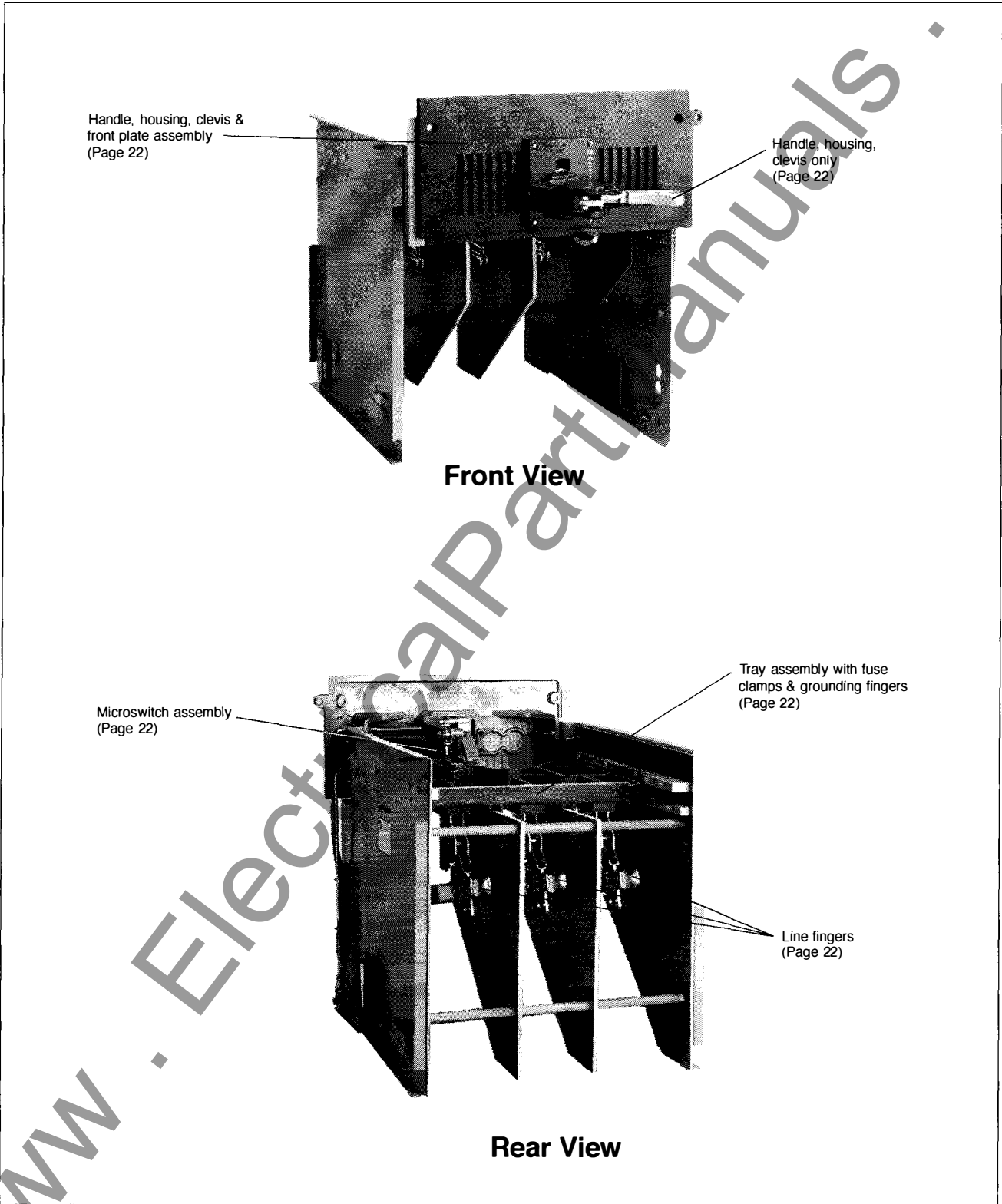

www.ElectricalPartManuals.com

Isolating Switch, 800 Amp, 7200 Volt, Type LFM-8

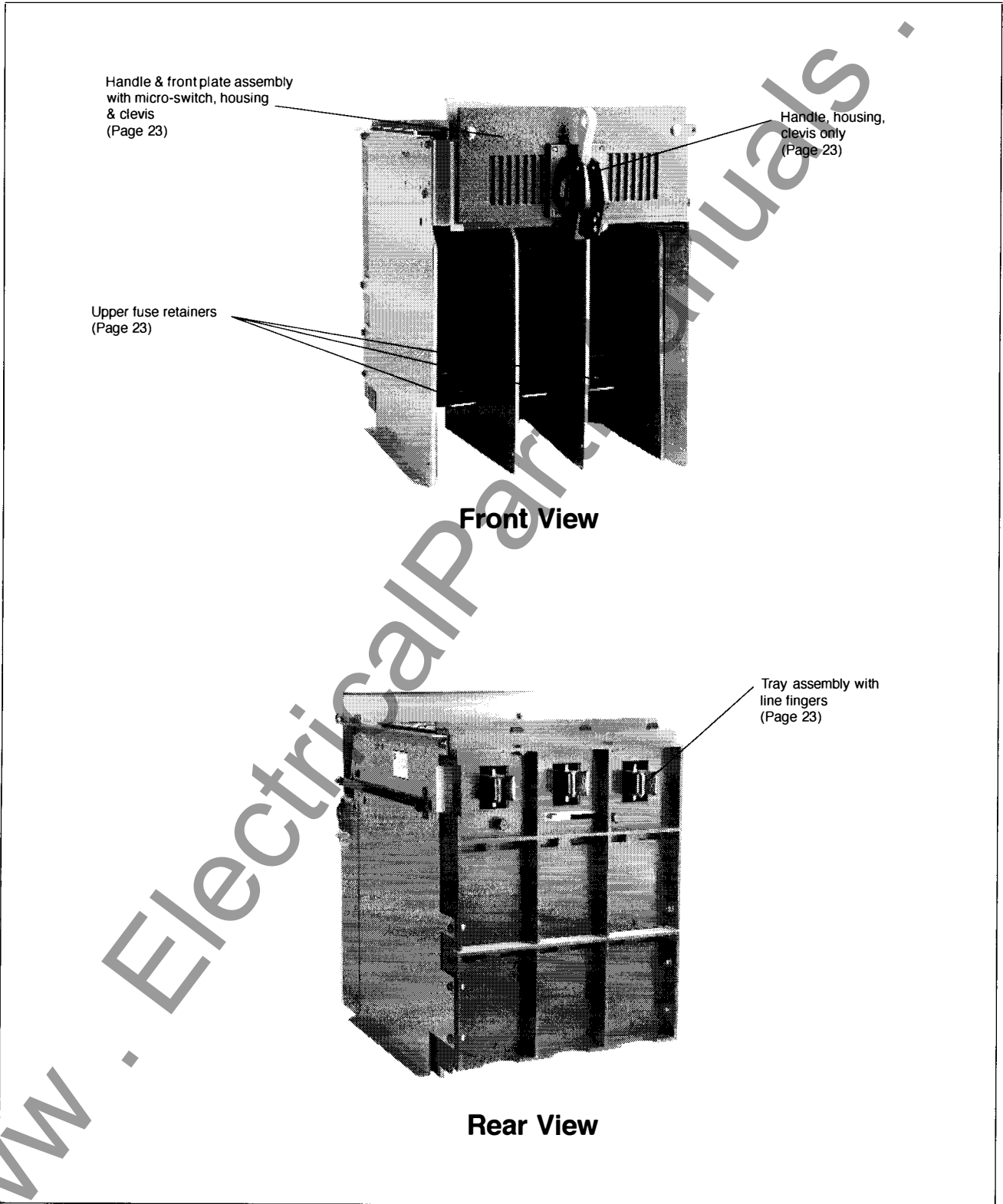

www.ElectricalPartManuals.com

Isolating Switch, 400 Amp, 7200 Volt Max.

Slide-Out design Type 72LFS-4 complete isolating switch with Microswitch
Approximate shipping weight 75 lbs. (34 kg.)

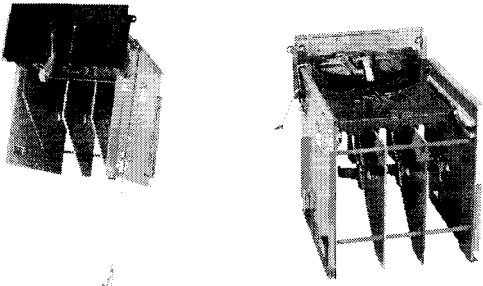

Front **Rear**

Style Number 2147A41G21

Roll-Out design Type 72LFR-4 complete isolating switch with microswitch.
Approximate shipping weight 75 lbs. (34 kg.)



Front **Rear**

Style Number 2147A41G01

Handle and front plate assembly with microswitch

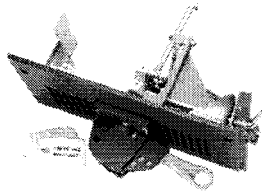

Style Number 2147A41G18

Handle, housing, clevis only



Style Number 2147A41G08

Microswitch assembly



Mounting of microswitch

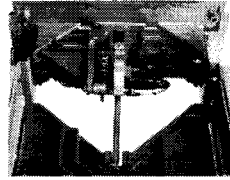

Style Number 2147A01G01

Tray assembly with fuse clamps, grounding fingers, and line fingers

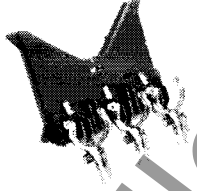

Style Number 2147A41G22

Grounding fingers, Qty. 6

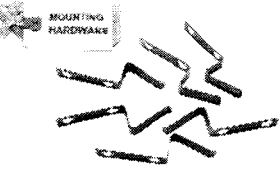

Style Number 2147A21G21

Mechanical interlock parts kit



Style Number 2147A41G23

www.ElectricalPartManuals.com

Isolating Switch, 800 Amp, 7200 Volt Max.

Type LFM-8 complete isolating switch with microswitch
Approximate shipping weight 100 lbs. (45 kg.)

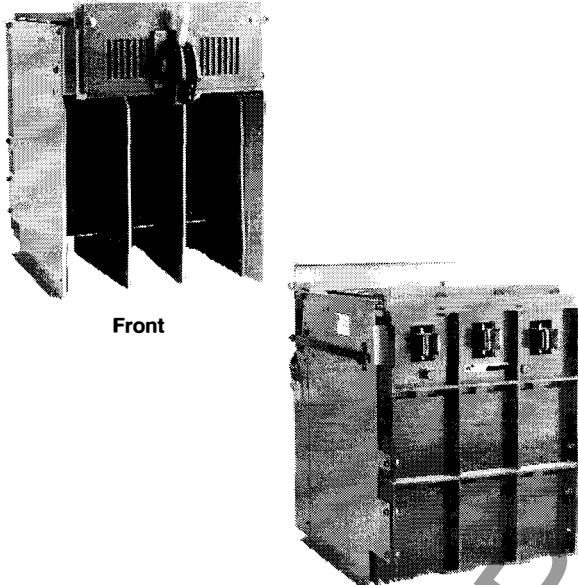

Front

Rear

Style Number 2147A81G01

Microswitch assembly



Mounting of microswitch

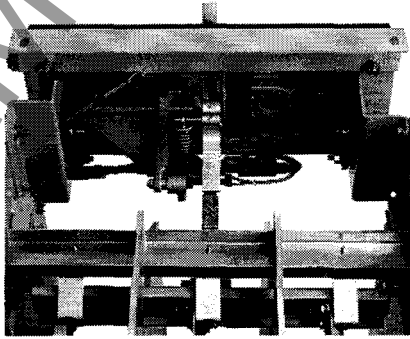

Style Number 2147A01G01

Tray assembly with line fingers

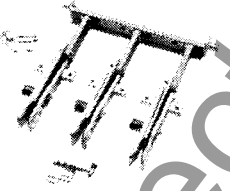

Style Number 2147A81G22

Grounding bar assembly with fingers

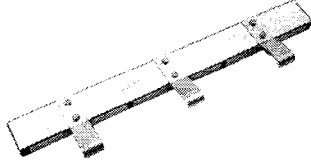

Style Number 2147A71G20

Handle & front plate with microswitch

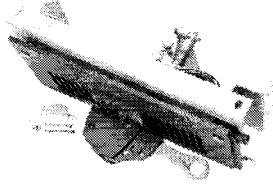

Style Number 2147A71G18

Line fuse cluster finger support assembly, Qty. 3

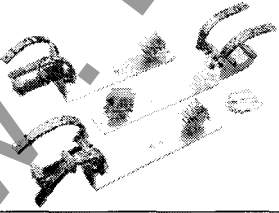

Style Number 2147A81G20

Grounding fingers, Qty. 6



Style Number 2147A71G23

Handle, housing, clevis only



Style Number 2147A71G08

www.ElectricalPartManuals.com

ADM Switch, 1200 Amp, 7200 Volt Max.

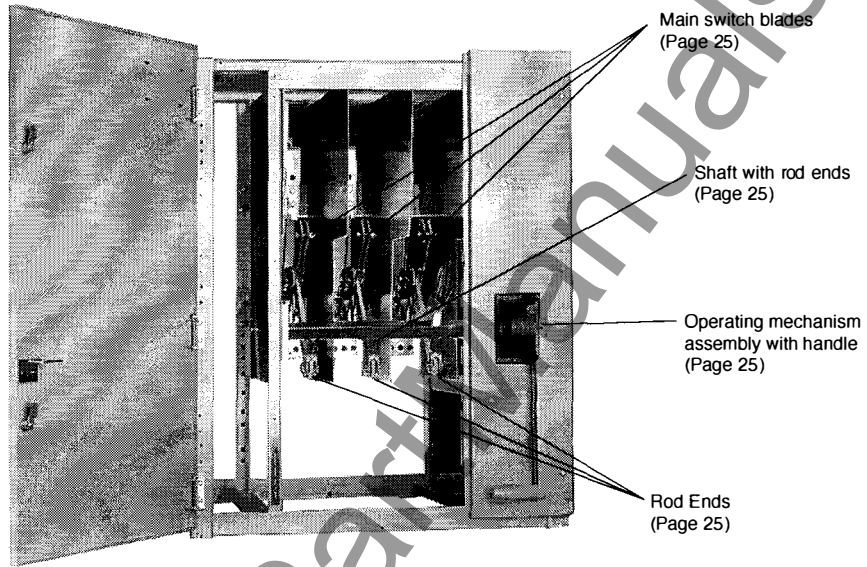

Front View

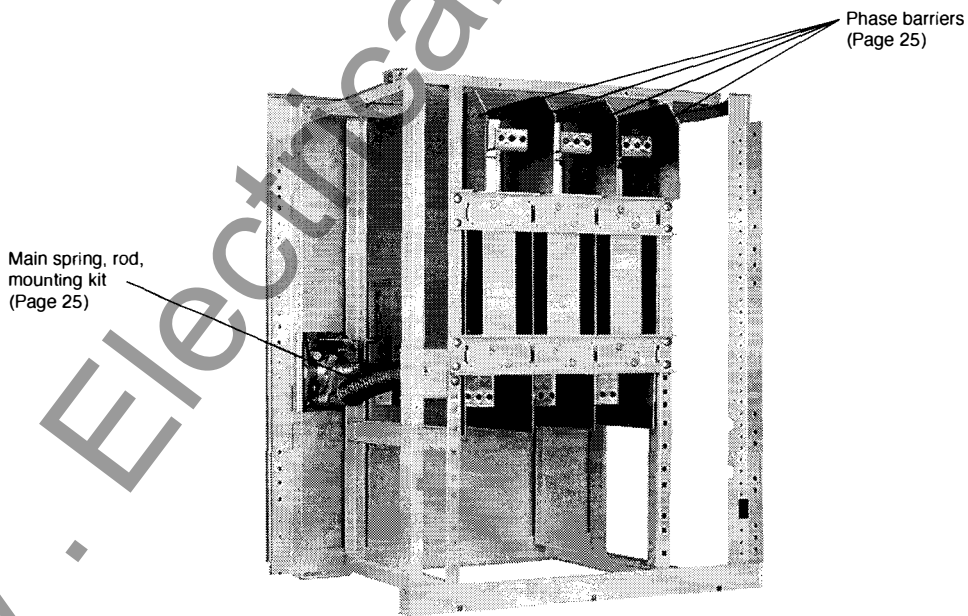

Rear View

www.ElectricalPartManuals.com

ADM Switch, 1200 Amp, 7200-Volt Max.

ADM Switch in welded frame assembly, with front door.
Nominal 45 in. high

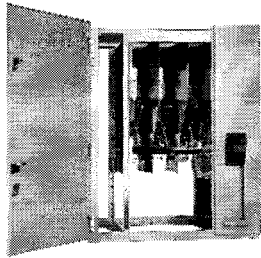

Front

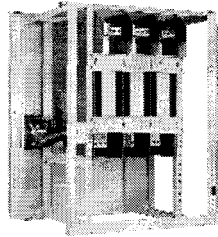

Rear

Style Number 2147A02G01

Mechanical latch lever mechanism

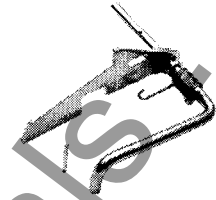

Style Number 2147A02G12

Rod ends, Qty. 3

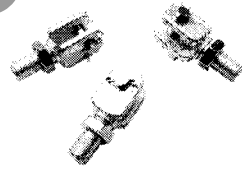

Style Number 2147A02G08

Arc chute, Qty. 3

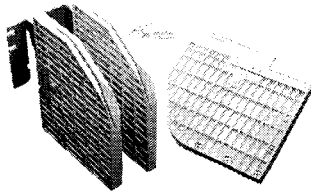

Style Number 2147A02G02

Shaft (for handle) with roll pins

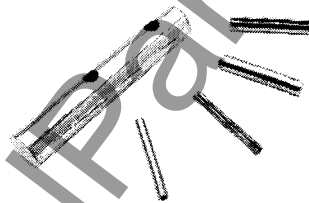

Style Number 2147A02G10

Main switch blades, Qty. 3

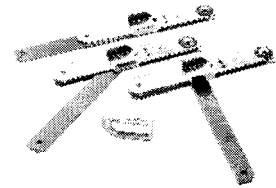

Style Number 2147A02G04

Main spring, rod, mounting

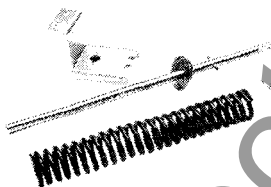

Style Number 2147A02G05

Shaft with rod ends

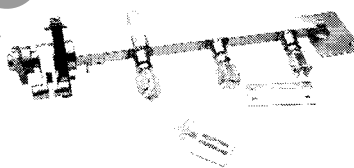

Style Number 2147A02G09

Operating mechanism assembly,
with handle

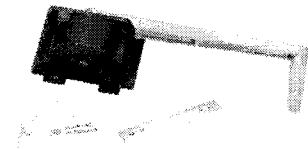

Style Number 2147A02G07

Main stationary contacts, Qty. 3

Photo not available
for this printing

Style Number 2147A02G03

Electrical interlock operating mechanism,
with 2 N.O., 2 N.C. electrical
interlocks

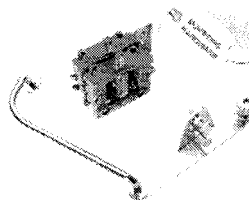

Style Number 2147A02G11

Flicker blade assembly, Qty. 3

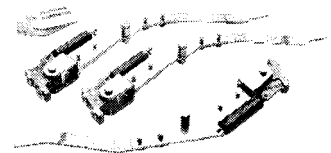

Style Number 2147A02G06

www.ElectricalPartManuals.com

ADM Switch, 1200 Amp, 7200-Volt Max.

Phase barriers for non-fused ADM switch	
	
Style Number	2147A020G20

Phase barrier for vertical mounted fuse	
	
Style Number	2147A02G21

Phase barriers for horizontal mounted fuses	
	
Style Number	2147A02G22

www.ElectricalPartManuals.com

MBA (Main Breaker Ampgard)

Main Breaker Element

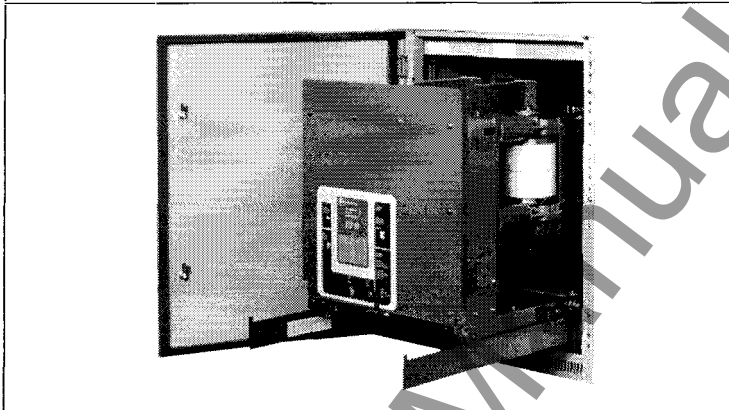

Circuit Breaker Rating @ 60Hz			Style Number
Amperes	Voltage	Interruption Rating	
1200A	4.16KV	250MVA	2147A98G12
	4.16KV	350MVA	2147A98G13
	7.2KV	500MVA	2147A98G14
2000A	4.16KV	250MVA	2147A98G20
	4.16KV	350MVA	2147A98G21
	7.2KV	500MVA	2147A98G22
3000A	4.16KV	250MVA	2147A98G30
	4.16KV	350MVA	2147A98G31
	7.2KV	500MVA	2147A98G32

www.ElectricalPartManuals.com

Reduced Voltage Solid State (RVSS)

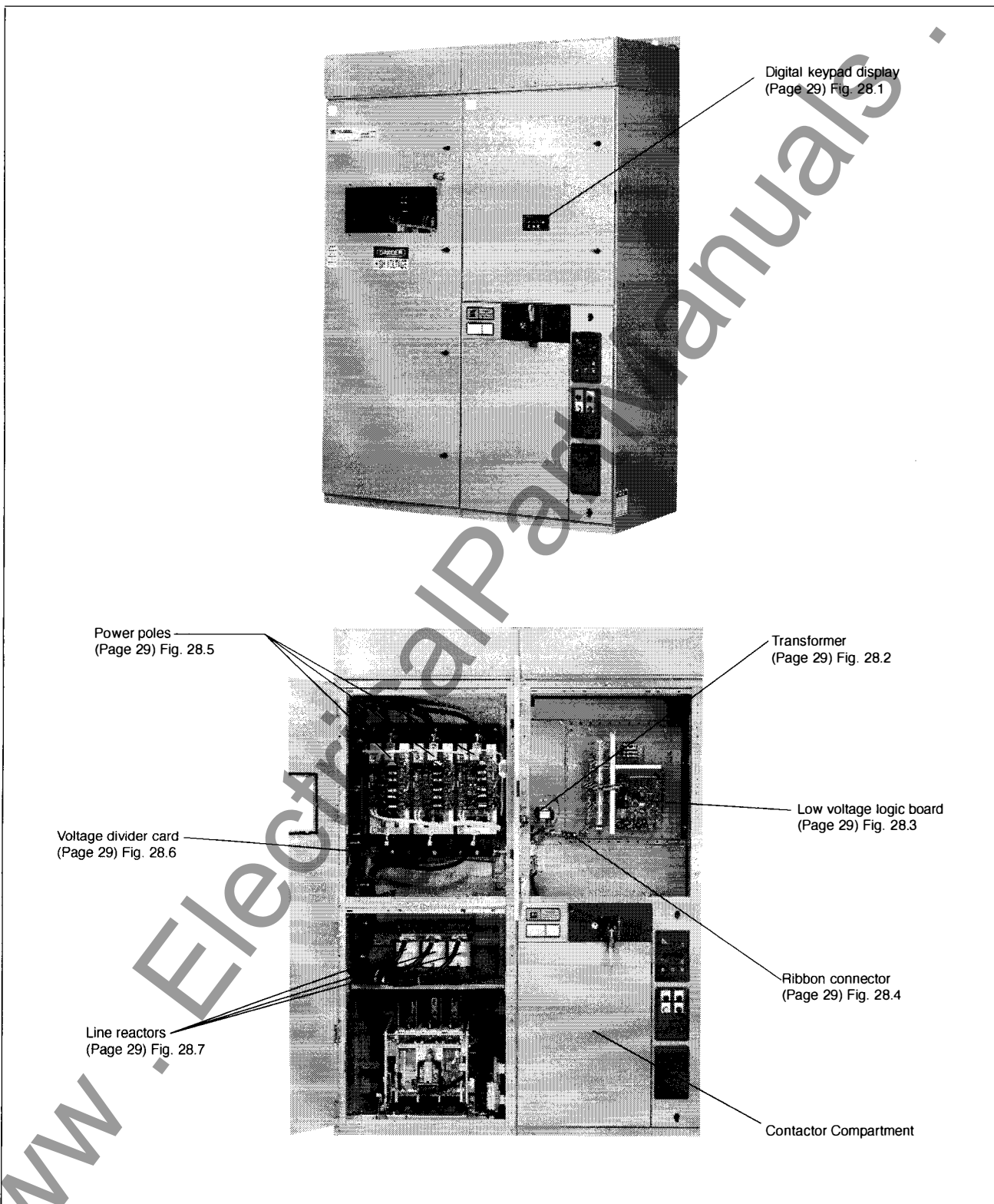

www.ElectricalPartManuals.com

Reduced Voltage Solid State (RVSS)

Power pole compartment

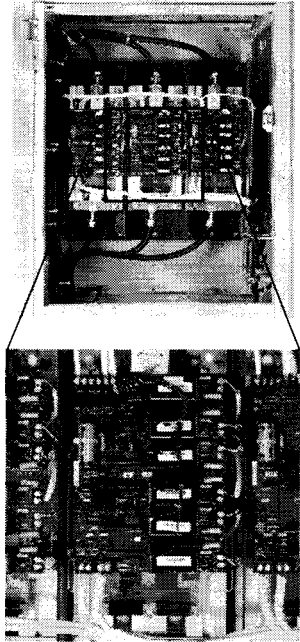

close up of power pole

Fig. No.	Description	Style Number
28.5	Power pole 2.5KV, 750HP(Qty.3)	2147A55G04
	Power pole 2.5KV, 1500HP(Qty.3)	2147A55G05
	Power pole 5.0KV, 1500HP(Qty.3)	2147A55G06
	Power pole 5.0KV, 3000HP(Qty.3)	2147A55G07

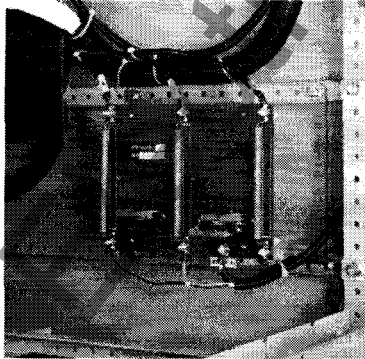

Fig. No.	Description	Style Number
28.6	Voltage divider card	2147A55G09

Main control logic compartment

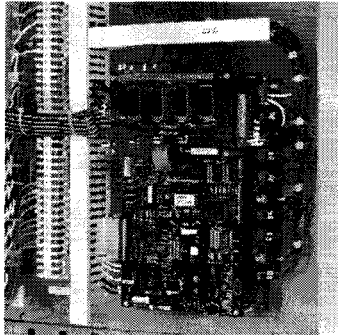
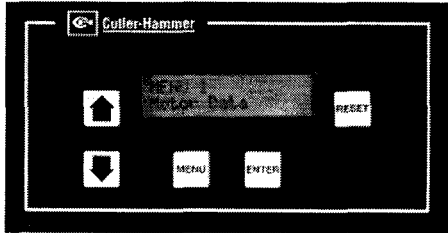

Fig. No.	Description	Style Number
28.2	Transformer	2147A55G10
28.4	Ribbon connector	2147A55G02



28.3	Low voltage logic board	2147A55G01
------	-------------------------	------------



28.1	Digital keypad display	2147A55G01
------	------------------------	------------

www.ElectricalPartManuals.com

Reduced Voltage Solid State (RVSS)

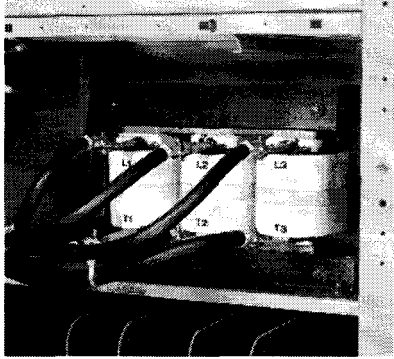
Reactor Compartment		
		
Fig. No.	Description	Style Number
28.7	Line reactor 4.16KV, 100 Amp	2147A55G11
	Line reactor 4.16KV, 200 Amp	2147A55G12
	Line reactor 4.16KV, 400 Amp	2147A55G13

Contactor Compartment	
<p>Photo not available for this printing</p>	
<p>Photo not available for this printing</p>	
Description	Style Number
Current transformers	2147A55G03

www.ElectricalPartManuals.com

AMPGARD Assembly/Structural Parts

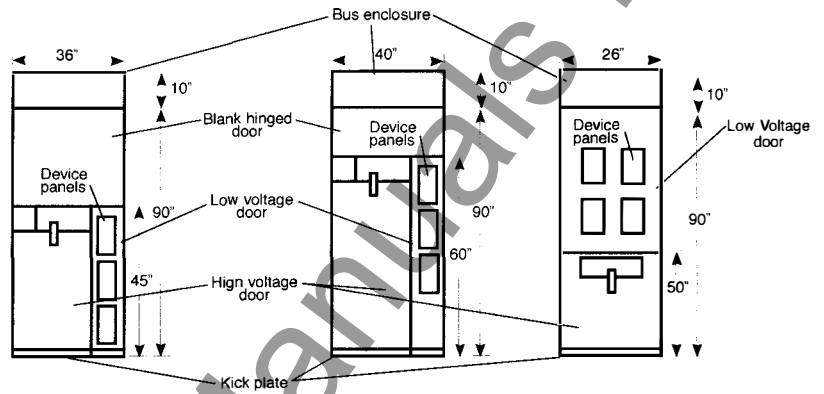

		400-Amp	800-Amp	400-Amp Narrow
High-Voltage Door NEMA 1 ^①	Non-Reversing	45"High Style No. 2147A97G01	60"High Style No. 2147A97G01	50"High Style No. 2147A92G01
	Reversing	75"High Style No. 2147A97G02	—	—
Low-Voltage Door with 3 Device Panels NEMA 1 ^①	Non-Reversing	45"High Style No. 2147A94G03	60"High Style No. 2147A97G03	Style No. 2147A92G03
	Reversing	75"High Style No. 2147A94G04	—	—
Blank ^① Hinged Door NEMA 1	15"High	Style No. 2147A94G05	15"High Style No. 214797G05	—
	30"High	Style No. 2147A94G06	30"High Style No. 2147A97G06	—
	45"High	Style No. 2147A94G07	60"High Style No. 2147A97G07	—
Back Sheet	90"High	Style No. 2147A97G08	90"High Style No. 2147A97G08	Style No. 2147A92G08
Bus Enclosure Empty		Style No. 2147A94G11	Style No. 2147A97G11	Style No. 2147A92G11
Bus Enclosure With Insulators, 1200-Amp Copper Bus, 1/4" x 4" Non-Insulated, Non-Plated		Style No. 2147A94G12	Style No. 2147A97G12	Style No. 2147A92G12
Bus Enclosure Gap Kit NEMA 1 only	10" Height	Style No. 2147A90G03	Style No. 2147A90G03	Style No. 2147A90G03
	20" Height	Style No. 2147A90G04	Style No. 2147A90G04	Style No. 2147A90G04
Kick Plate Front		Style No. 2147A94G21	Style No. 2147A97G21	Style No. 2147A92G21
Vertical Bus - One High Starter (Lower Position)		Style No. 2147A94G22	Style No. 2147A97G22	Style No. 2147A92G22
Vertical Bus - Two High Starter Between Upper and Lower Isolating Switch		Style No. 2147A94G23	—	—
Vertical Bus - Between Upper Isolating Switch and Main Bus		Style No. 2147A94G24	—	—
Vertical Bus Support Kit - With (2) Three-Phase Bus Clamp Assemblies		Style No. 2147A94G25	Style No. 2147AG25	Style No. 2147A92G25
Device Panels	22mm KO Qty.3	Style No. 2147A90G22	Style no. 2147A90G22	Style No. 2147A90G22
	30mm KO Qty.3	Style No. 2147A90G30	Style No. 2147A90G30	Style No. 2147A90G30

① If replacing narrow flange doors with above, remove vertical trim strip and drill holes for mounting. Narrow flange supplied prior to July 1983.

www.ElectricalPartManuals.com

AMPGARD Assembly/Structure Parts

Formed side sheet, common to all NEMA 1 structures; nominal 90 in. high

Photo not available for this printing

Style Number 2147A90G01

400-Amp welded cell, nominal 45 in. high, 36 in. wide, standard, for use with isolating switch and power fuses. Complete with H.V. door and L.V. door with "works in a drawer" (not shown in photo)

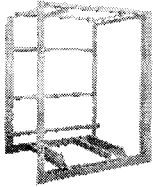

Style Number 2147A91G04

400-Amp welded cell, nominal 30 in. high, 36 in. wide, complete with H.V. door (not shown in photo) reversing. (Reversing cells are used in starters for reversing contactors, shorting and run contactors of reactor and auto-transformer and multispeed starters)

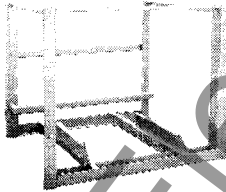

Style Number 2147A91G05

Works in a drawer with slide rails including 3 device panels

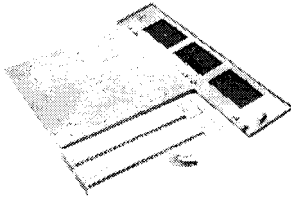

Description	Style Number
400-Amp cell nominal 45 in. high	2147A91G13
800-Amp cell nominal 60 in. high	2147A91G14

Door fastener kit Qty.10

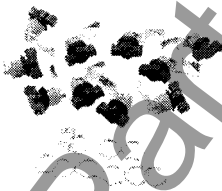

Style Number 2147A91G16

12-prong receptical with wires



Description	Style Number
400-Amp contactor	2147A15G03
800-Amp contactor	2147A15G12

400-Amp type SJA roll-out contactor line stab assembly, 3 copper stabs plus insulator



Style Number 2147A49G20

400-Amp type SJA roll-out contactor load stab assembly, 3 copper stabs plus insulator



Style Number 2147A49G07

400-Amp, type SJD narrow design contactor load standard assembly, 3 copper stabs plus insulator

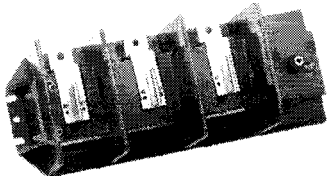

Style Number 2147A21G30

www.ElectricalPartManuals.com

AMPGARD Assembly/Structure Parts

400-Amp, type SJA, roll-out contactor main load cables	
	
Description	Style Number
1/0 cable if C.T. ratio is below 250/5	2147A15G18
4/0 cable if C.T. ratio is 250/5 or above	2147A15G19

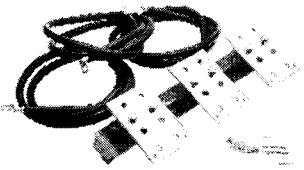
400-Amp, type SJS, slide-out contactor main load cables with load adaptor	
	
Description	Style Number
1/0 cable if C.T. ratio is below 250/5	2147A15G13
4/0 cable if C.T. ratio is 250/5 or above	2147A15G14

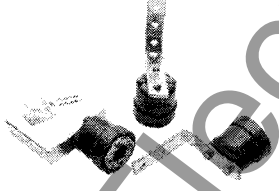
400-Amp, type SJD, narrow design load connector	
	
Style Number	2147A21G32

400-Amp isolating switch incoming line stab assembly	
	
Style Number	2147A21G19

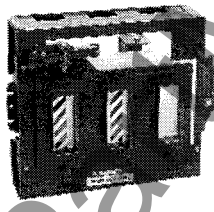
400-Amp isolating switch incoming line stab assembly with shutter mechanism & finger barrier for SJD narrow design	
	
Style Number	2147A21G33

800-Amp isolating switch line stab assembly and barriers, Qty.3	
	
Style Number	2147A81G11

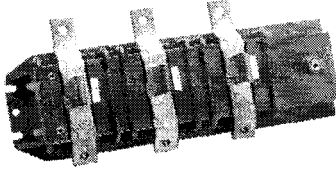
400-Amp type SJD narrow design contactor incoming line stab assembly	
	
Style Number	2147A21G31

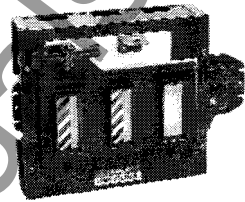
400-Amp isolating switch incoming line stab assembly with shutter mechanism and finger barrier for SJA & SJS types	
	
Style Number	2147A41G11

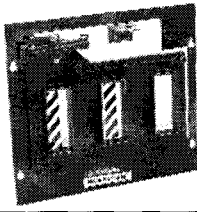
400-Amp isolating switch shutter mechanism only	
	
Style Number	2147A41G12

800-Amp isolating switch shutter mechanism	
	
Style Number	2147A81G19

www.ElectricalPartManuals.com

AMPGARD Assembly/Structure Parts

Insulated main bus support kit

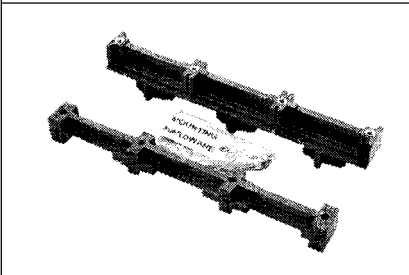

Style Number 2147A21G35

Insulated main bus support

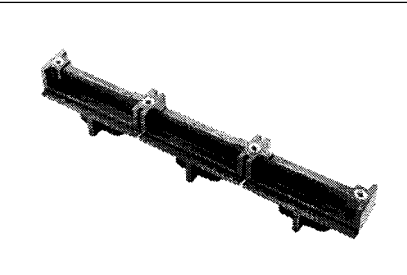

Style Number 2147A21G36

ADM switch barrier screen

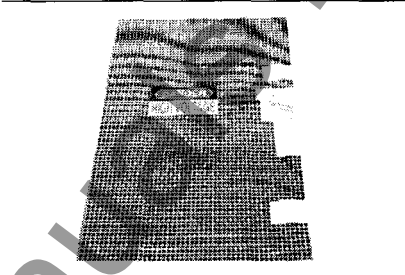

Style Number 2147A02G16

Non-insulated main bus support

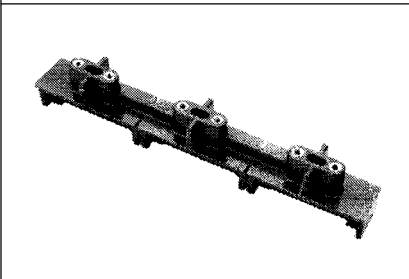

Style Number 2147A21G37

Insulated main bus clamp

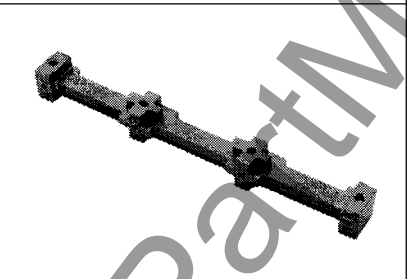

Style Number 2147A21G38

400-Amp type SJS slide-out load connection

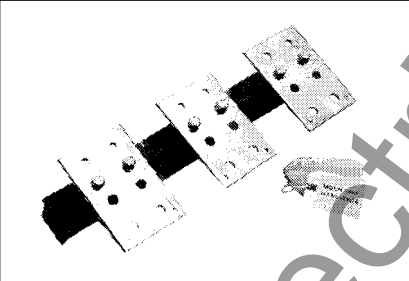

Style Number 2147A21G40

800-Amp contactor load or line stab assembly, complete with mounting

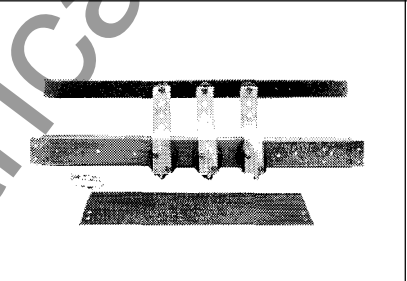

Style Number 2147A89G03

www.ElectricalPartManuals.com

AMPGARD Accessories

Tools, contactor, closing tool

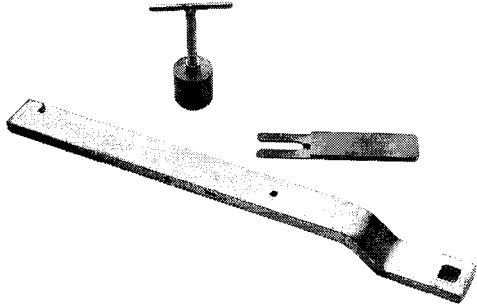

Style Number 2147A47G20

Ampgard lube kit, contains: (2) tubessilicon grease for iso-switch stabs and (1) jar graphite grease for ADM switches



Style Number 2147A48G31

Contactor tune-up kit 400-Amp SJO

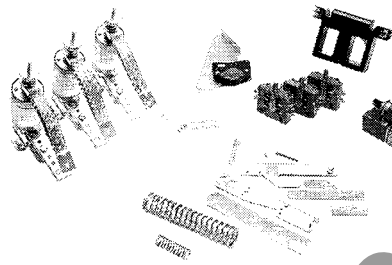

Style Number 2147A99G01

Contactor tune-up kit 400-Amp SJA

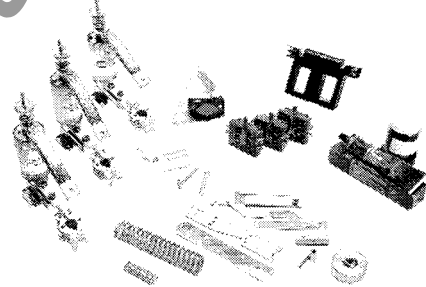

Style Number 2147A99G03

Contactor tune-up kit 800-Amp SJO

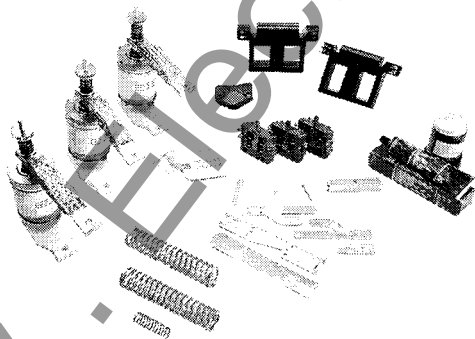

Style Number 2147A99G02

Contactor tune-up kit 800-Amp SJA

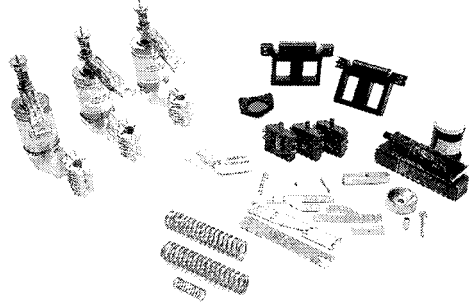

Style Number 2147A99G04

* Tune-up kits include: vacuum bottles, coil, interlocks, lube kit, miscellaneous parts kit, bottle wrench and feeler gauge.

www.ElectricalPartManuals.com

Recommended Spare Parts For Stock

The following are recommended "Startup" and "Running" spare parts for AMPGARD™ Starters.

Description	Part Number	Quantity
400 Ampere "Startup" Spares		
Coil (120V)	2147A48G11	1
Coil (240V)	2147A48G21	1
L-63 Coil Interlock	578D461G03	1
L-64 Auxiliary Interlock	843D943G21	1
Fuse, Primary for CPT (Set of 2 or 3)	page 18 *	1
Main Power Fuses (Max. 230A-12R)(Set of 3)	page 37 *	1
Main Power Fuses (Max. 450A-24R)(Set of 3)	page 37 *	1
400 Ampere "Running" Spares		
Inc. Line Stab W/Shutter Mechanism	2147A41G11	1
Load Stab (for Rollout Only)	2147A49G05	1
Iso. Switch Auxiliary Interlock	2147A01G01	1
Vacuum Bottle Subassy. (Rollout Design)(Set of 3)	2147A47G03	1
Vacuum Bottle Subassy. (Slideout Design)(Set of 3)	2147A47G13	1
800 Ampere "Startup" Spares		
Dual Coil (120V)	2147A88G11	1
Dual Coil (240V)	2147A88G12	1
L-63 Coil Interlock	578D461G03	1
L-64 Auxiliary Interlock	843D943G21	1
Fuse, Primary for Cpt (Set of 2 or 3)	page 18 *	1
Main Power Fuses (Set of 3)	page 37 *	1
800 Ampere "Running" Spares		
Shutter Assembly	2147A81G19	1
Contacto Load Stab Assembly	2147A89G03	1
Iso. Switch Auxiliary Interlock	2147A01G01	1
Vacuum Bottle Subassy. (Set of 3)	2147A87G13	1

* See order outline drawing for specific current rating, voltage class and usage (starter or feeder switch) before selecting from tables.

www.ElectricalPartManuals.com

AMPGARD Main fuse kits (Qty. 3 fuses/kit)

5.0 KV Maximum (4.8 KV Nominal)

Type	Rating	Style Number
CLS 400A Starter	30A - 1R	2A98253G01
	70A - 2R	2A98253G02
	100A - 3R	2A98253G03
	130A - 4R	2A98253G04
	150A - 5R	2A98253G05
	170A - 6R	2A98253G06
	200A - 9R	2A98253G07
	230A - 12R	2A98253G08
	390A - 18R	2A98253G09
	450A - 24R	2A98253G10
CLS 800A Starter	450A - 24R	2A98253G11
	650A - 36R	2A98253G12
	800A - 44R	2A98253G13
CLE 400A Starter & ADM Switch	10E	2A98253G41
	15E	2A98253G42
	20E	2A98253G43
	25E	2A98253G44
	30E	2A98253G45
	40E	2A98253G46
	50E	2A98253G47
	65E	2A98253G48
	80E	2A98253G49
	100E	2A98253G50
	125E	2A98253G51
	150E	2A98253G52
	200E	2A98253G53
	225E	2A98253G54
	250E/280X	2A98253G55
	300E/325X	2A98253G56
350E	2A98253G57	
400E	2A98253G58	
450E	2A98253G59	
CLS 800A Starter	600E	2A98253G60
	750E	2A98253G61
CLE ADM Switches	600E ^①	2A98253G62
	750E ^①	2A98253G63
	1100E ^{①②}	2A98253G64
	1350E ^{①②}	2A98253G65

8.3 KV Maximum (7.2 KV Nominal)

Type	Rating	Style Number
CLS 400A Starter	70A - 2R	2A98253G21
	100A - 3R	2A98253G22
	130A - 4R	2A98253G23
	150A - 5R	2A98253G24
	170A - 6R	2A98253G25
	200A - 9R	2A98253G26
	230A - 12R	2A98253G27
	390A - 18R	2A98253G28
	450A - 24R	2A98253G29
CLS 800A Starter	450A - 24R	2A98253G30
	650A - 36R	2A98253G31
	800A - 44R	2A98253G32
CLE 400A Starter & ADM Switch	10E	2A98253G71
	15E	2A98253G72
	20E	2A98253G73
	25E	2A98253G74
	30E	2A98253G75
	40E	2A98253G76
	50E	2A98253G77
	65E	2A98253G78
	80E	2A98253G79
	100E	2A98253G80
	125E	2A98253G81
	150E	2A98253G82
	175E	2A98253G83
	200E	2A98253G84
	250E	2A98253G85
	300E	2A98253G86
350E	2A98253G87	

① Bolted in.
② Two fuses per phase.

www.ElectricalPartManuals.com

Notes

www.ElectricalPartManuals.com

Notes

www.ElectricalPartManuals.com

www.ElectricalPartManuals.com

Notes



www.ElectricalPartManuals.com

www.ElectricalPartManuals.com