



Westinghouse I.L. 41-841B

# INSTALLATION • OPERATION • MAINTENANCE I N S T R U C T I O N S

## TRB - 1 BLOCKING VALVE AND TRB - 1 TEST UNIT TRB - STATIC TRIPPING UNIT

### PART I-TYPE TRB STATIC TRIPPING UNIT

#### APPLICATION

The TRB static tripping unit is an auxiliary device energized by protective relays to trip circuit breakers in a double trip relaying scheme. It is suitable to cases where the total trip current of the two breakers is within the relay contact rating, usually 30 amperes. The TRB unit can also be used for isolation of multiple trip paths to one breaker.

#### CONSTRUCTION AND OPERATION

The TRB auxiliary units consists of two silicon rectifiers and two capacitors mounted in a small molded case. Each rectifier has a capacitor connected in parallel with it and each set is brought out to separate terminals.

The TRB unit is energized through the trip contacts of the protective relays of which a typical application is illustrated in Fig. 2. Contacts of relay #1 trips breaker #1, and similarly, relay #2 trips breaker #2. Relay contacts PR trips both breakers. The operation of relay #1 will energize only breaker #1. Using the TRB unit, current cannot flow from relay #1 to breaker trip coil #2 because of diode D1.

Relays associated with each particular breaker are isolated from the other breaker, yet both breakers can be tripped without additional time delay by operating a common relay.

### CHARACTERISTICS

The TRB static tripping unit is available in two styles. One style applies to 48/125 volt D.C. service and the other is used for 250 volt D.C. applications. Specific characteristics are shown in Table I.

### PART II-TYPE TRB-1 BLOCKING VALVE

#### APPLICATION

The TRB-1 blocking valve is an auxiliary device to be used as a directional valve in a relaying scheme.

#### CONSTRUCTION AND OPERATION

The TRB-1 blocking valve consists of a single silicon rectifier and one capacitor mounted in a small molded case.

The TRB-1 unit is energized through the trip contacts of the protective relay such that trip current is allowed to flow in one direction and is blocked in the opposite direction.

### CHARACTERISTICS

The TRB-1 blocking valve is available in two styles. One style applies to 48/125 volt D.C. service and the other is used for 250 volt D.C. applications. Specific characteristics are shown in Table I.

TYPE TRB AND TRB-1 UNITS

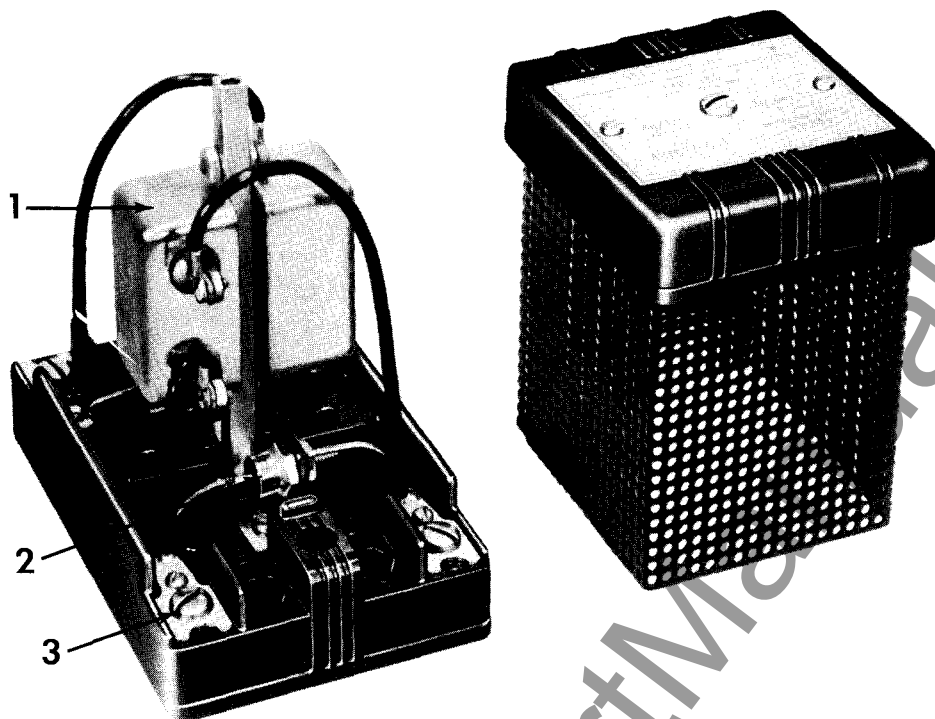

Fig. 1. Type TRB static tripping unit with cover removed. 1-Capacitor. 2-Silicon Rectifier. 3-Terminal. 4-Cover.

TABLE I  
(APPLICABLE TO PART I AND PART II)

Style & Type	Rating	Rectifier Used	One Second Rating	Maximum Reverse Volts	Maximum Reverse Current †	Forward Voltage Drop † †
TRB 407C275GO1	48/125V.D.C.	304-F	30 Amperes	300	4 MA.	1.5 Volts
TRB 407C275GO2	250V.D.C.	304-M	30 Amperes	600	4 MA.	1.5 Volts
TRB-1 184A414G12	48/125V.D.C.	304-F	30 Amperes	300	4 MA.	1.5 Volts
TRB-1 184A414G13	250V.D.C.	304-M	30 Amperes	600	4 MA.	1.5 Volts

† At Rated d-c Voltage  
† † At 30 amperes d.c

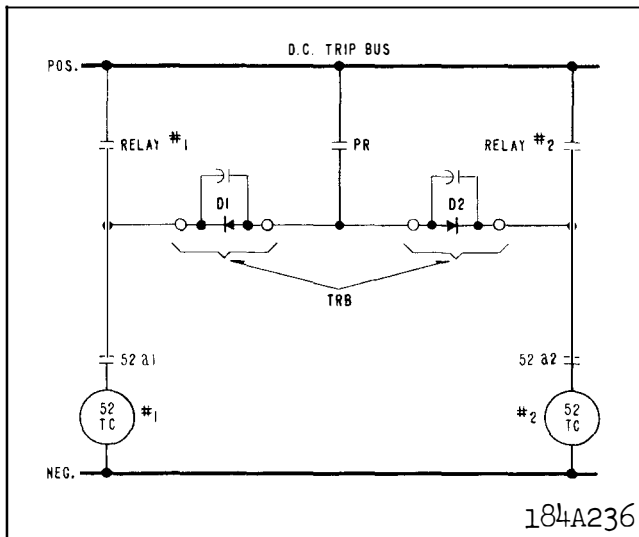

Fig. 2. Operational Schematic

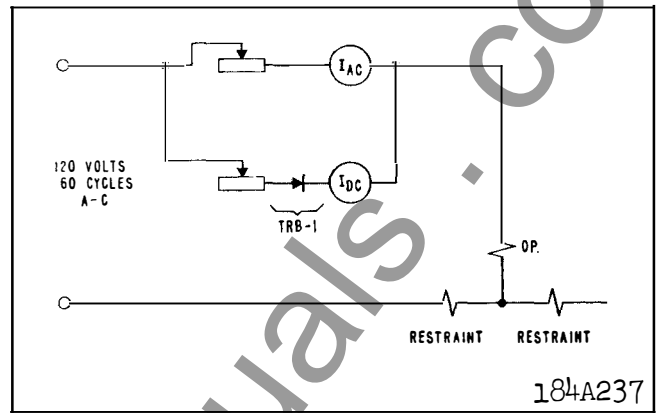

Fig. 3. Typical Test Setup of Type HU and Type HU-1 Relay using Type TRB-1 Test Unit.

**PART III - TYPE TRB-1 TEST UNIT - S#407C275G03**

**PART IV - APPLICABLE TO BOTH TRB AND TRB-1**

**APPLICATION**

**INSTALLATION**

The primary application of the TRB-1 test unit is as a second harmonic generator for testing the harmonic restraint unit of the Types HU and HU-1 transformer differential relays.

The units should be mounted on switchboard panels or their equivalent in a location free from dirt, moisture, and heat. Mount the units by means of two mounting screws directly to the panel.

**CONSTRUCTION AND OPERATION**

**RENEWAL PARTS**

The TRB-1 test unit consists of a single silicon rectifier mounted in a small molded case. It is energized by an A.C. 60 cycle source as shown in Fig. 3. The half wave rectifier current from the TRB-1 combines with a 60 cycle A.C. current to produce a second harmonic wave which is introduced for test purposes into the harmonic restraint unit of the HU and HU-1 relays.

If one of the silicon rectifier units becomes damaged, it can be removed from its mounting bracket and replaced with a new rectifier ordered by type number as given in the section titled characteristics. When soldering the connection to the rectifier, it is preferable to use eutectic solder. Do not apply heat any longer than required to produce a satisfactory solder connection.

**CHARACTERISTICS**

The TRB-1 test unit is rated for 5 amperes con-

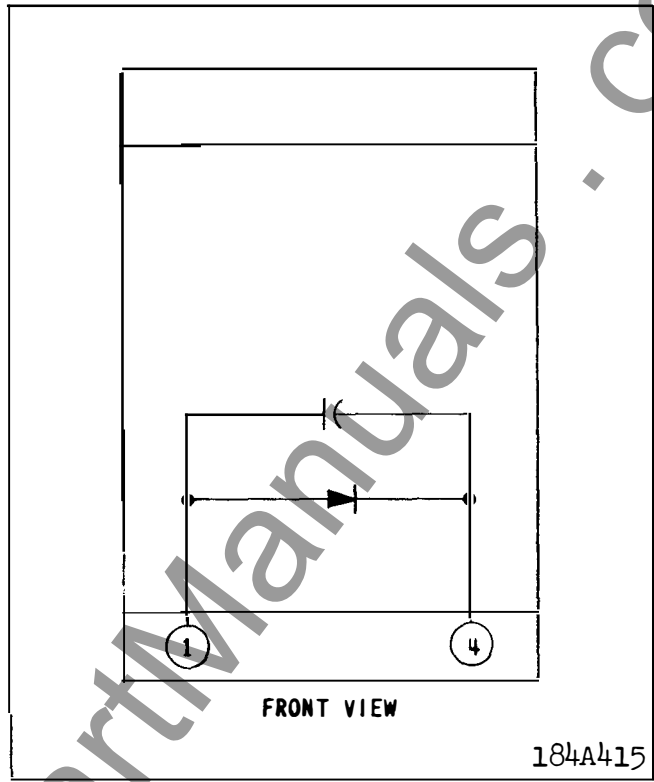
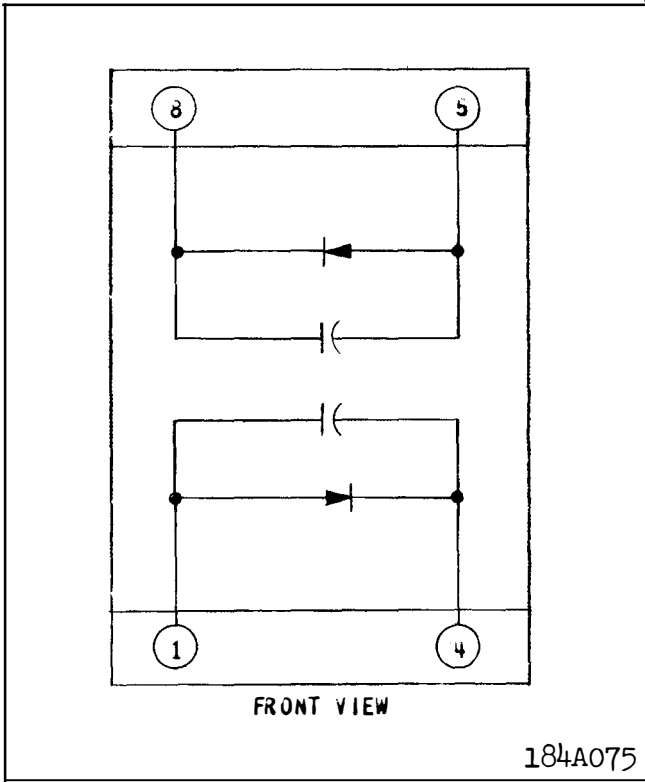

Fig. 4. Internal Schematic of Type TRB Static Tripping Unit.

Fig. 5. Internal Schematic of Type TRB-1 Blocking Valve.

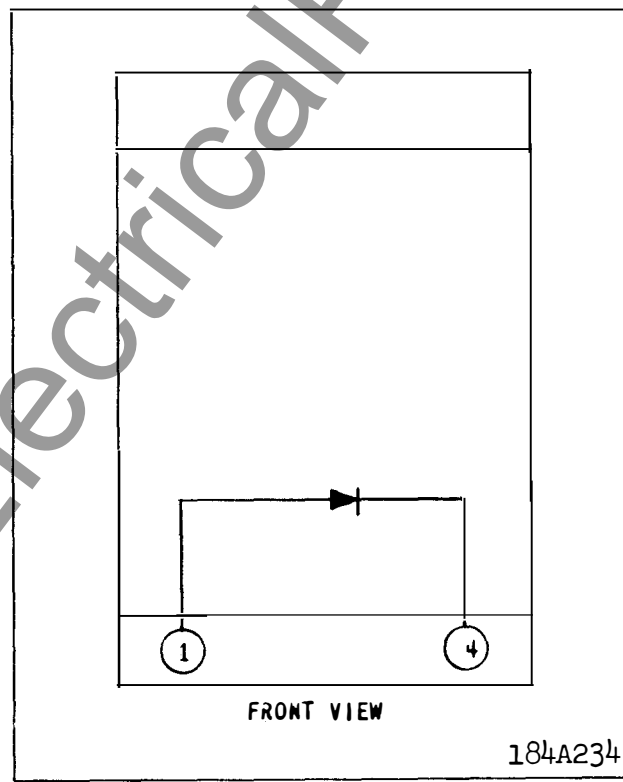

Fig. 6. Internal Schematic of Type TRB-1 Test Unit.

www.ElectricalPartManuals.com

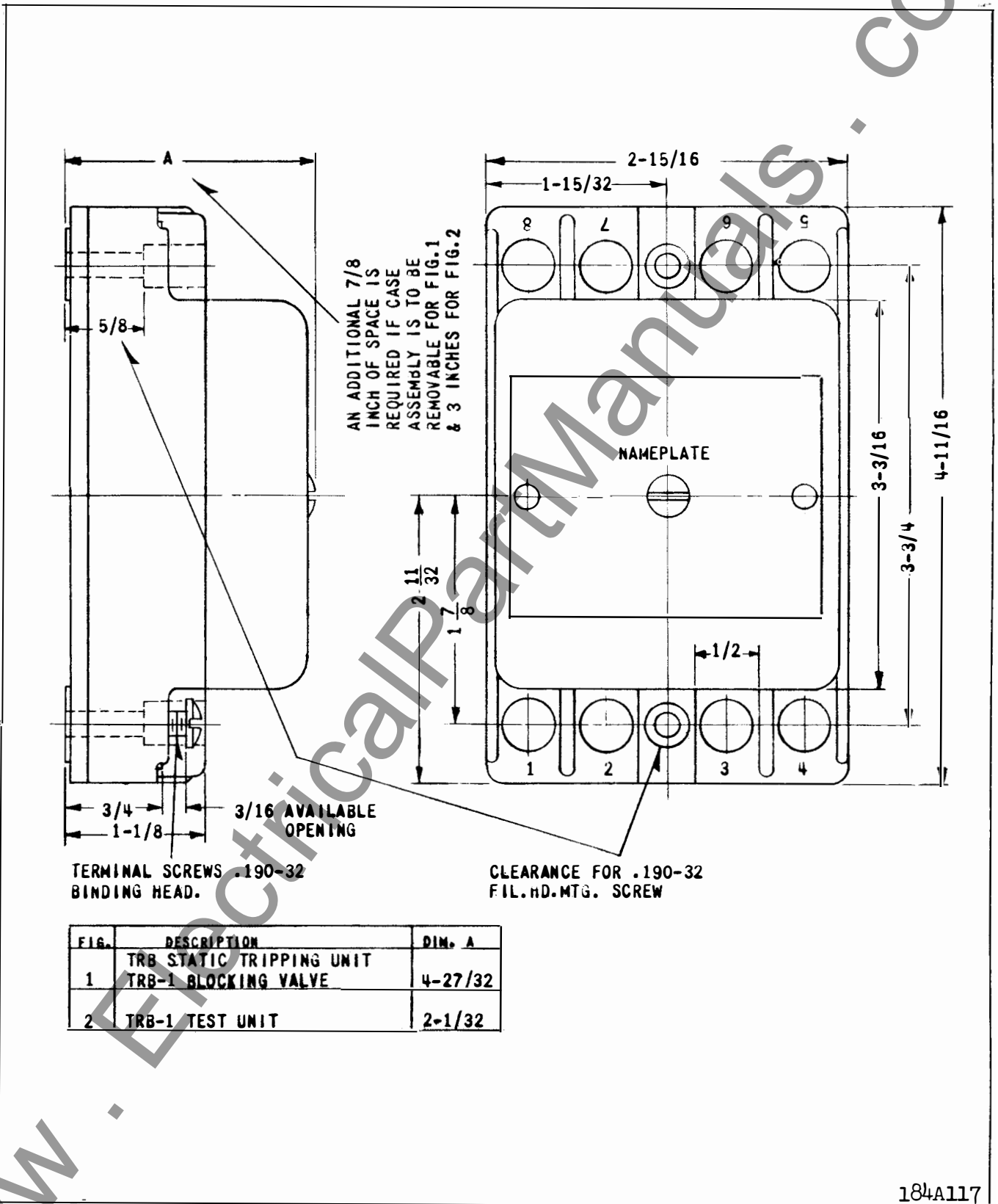

Fig. 7. Outline and Drilling Plan for Type TRB and TRB-1 Auxiliary Units.

184A117

[www.ElectricalPartManuals.com](http://www.ElectricalPartManuals.com)

[www.ElectricalPartManuals.com](http://www.ElectricalPartManuals.com)



**WESTINGHOUSE ELECTRIC CORPORATION**  
**RELAY DEPARTMENT**

**NEWARK, N. J.**

Printed in U. S. A.



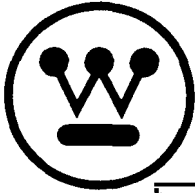

Westinghouse I.L. 41-841B

# INSTALLATION • OPERATION • MAINTENANCE I N S T R U C T I O N S

## TRB - 1 BLOCKING VALVE AND TRB - 1 TEST UNIT TRB - STATIC TRIPPING UNIT

### PART I-TYPE TRB STATIC TRIPPING UNIT

#### APPLICATION

The TRB static tripping unit is an auxiliary device energized by protective relays to trip circuit breakers in a double trip relaying scheme. It is suitable to cases where the total trip current of the two breakers is within the relay contact rating, usually 30 amperes. The TRB unit can also be used for isolation of multiple trip paths to one breaker.

#### CONSTRUCTION AND OPERATION

The TRB auxiliary units consists of two silicon rectifiers and two capacitors mounted in a small molded case. Each rectifier has a capacitor connected in parallel with it and each set is brought out to separate terminals.

The TRB unit is energized through the trip contacts of the protective relays of which a typical application is illustrated in Fig. 2. Contacts of relay #1 trips breaker #1, and similarly, relay #2 trips breaker #2. Relay contacts PR trips both breakers. The operation of relay #1 will energize only breaker #1. Using the TRB unit, current cannot flow from relay #1 to breaker trip coil #2 because of diode D1.

Relays associated with each particular breaker are isolated from the other breaker, yet both breakers can be tripped without additional time delay by operating a common relay.

### CHARACTERISTICS

The TRB static tripping unit is available in two styles. One style applies to 48/125 volt D.C. service and the other is used for 250 volt D.C. applications. Specific characteristics are shown in Table I.

### PART II-TYPE TRB-1 BLOCKING VALVE

#### APPLICATION

The TRB-1 blocking valve is an auxiliary device to be used as a directional valve in a relaying scheme.

#### CONSTRUCTION AND OPERATION

The TRB-1 blocking valve consists of a single silicon rectifier and one capacitor mounted in a small molded case.

The TRB-1 unit is energized through the trip contacts of the protective relay such that trip current is allowed to flow in one direction and is blocked in the opposite direction.

### CHARACTERISTICS

The TRB-1 blocking valve is available in two styles. One style applies to 48/125 volt D.C. service and the other is used for 250 volt D.C. applications. Specific characteristics are shown in Table I.

**TYPE TRB AND TRB-1 UNITS**

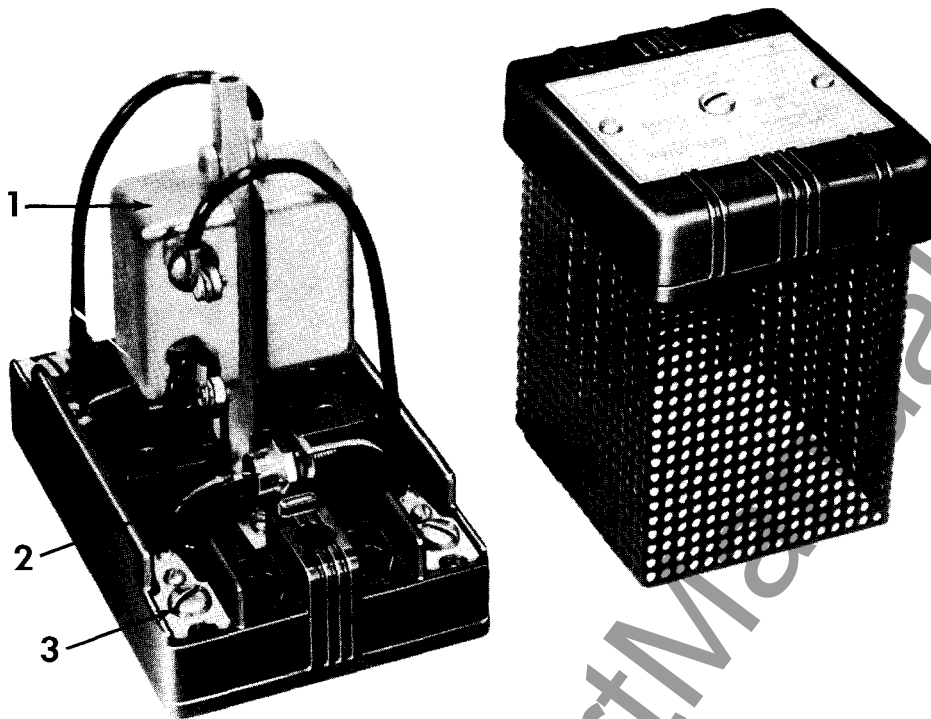

Fig. 1. Type TRB static tripping unit with cover removed. 1-Capacitor. 2-Silicon Rectifier. 3-Terminal. 4-Cover.

**TABLE I**  
(APPLICABLE TO PART I AND PART II)

Style & Type	Rating	Rectifier Used	One Second Rating	Maximum Reverse Volts	Maximum Reverse Current †	Forward Voltage Drop † †
TRB 407C275GO1	48/125V.D.C.	304-F	30 Amperes	300	4 MA.	1.5 Volts
TRB 407C275GO2	250V.D.C.	304-M	30 Amperes	600	4 MA.	1.5 Volts
TRB-1 184A414G12	48/125V.D.C.	304-F	30 Amperes	300	4 MA.	1.5 Volts
TRB-1 184A414G13	250V.D.C.	304-M	30 Amperes	600	4 MA.	1.5 Volts

† At Rated d-c Voltage  
† † At 30 amperes d.c

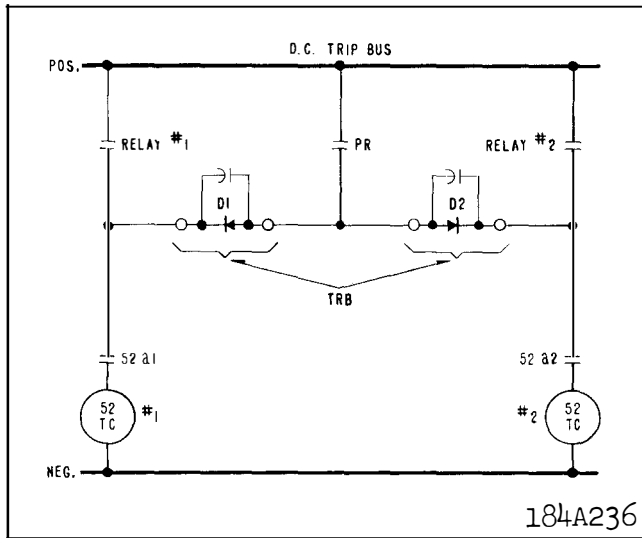

Fig. 2. Operational Schematic

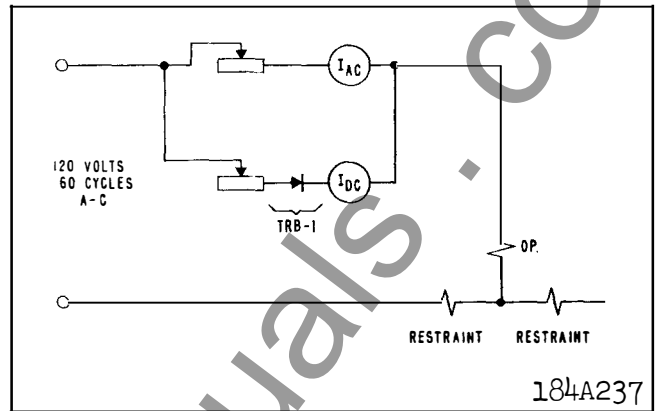

Fig. 3. Typical Test Setup of Type HU and Type HU-1 Relay using Type TRB-1 Test Unit.

**PART III - TYPE TRB-1 TEST UNIT - S#407C275G03**

**PART IV - APPLICABLE TO BOTH TRB AND TRB-1**

**APPLICATION**

The primary application of the TRB-1 test unit is as a second harmonic generator for testing the harmonic restraint unit of the Types HU and HU-1 transformer differential relays.

**INSTALLATION**

The units should be mounted on switchboard panels or their equivalent in a location free from dirt, moisture, and heat. Mount the units by means of two mounting screws directly to the panel.

**CONSTRUCTION AND OPERATION**

The TRB-1 test unit consists of a single silicon rectifier mounted in a small molded case. It is energized by an A.C. 60 cycle source as shown in Fig. 3. The half wave rectifier current from the TRB-1 combines with a 60 cycle A.C. current to produce a second harmonic wave which is introduced for test purposes into the harmonic restraint unit of the HU and HU-1 relays.

**RENEWAL PARTS**

If one of the silicon rectifier units becomes damaged, it can be removed from its mounting bracket and replaced with a new rectifier ordered by type number as given in the section titled characteristics. When soldering the connection to the rectifier, it is preferable to use entectic solder. Do not apply heat any longer than required to produce a satisfactory solder connection.

**CHARACTERISTICS**

The TRB-1 test unit is rated for 5 amperes con-

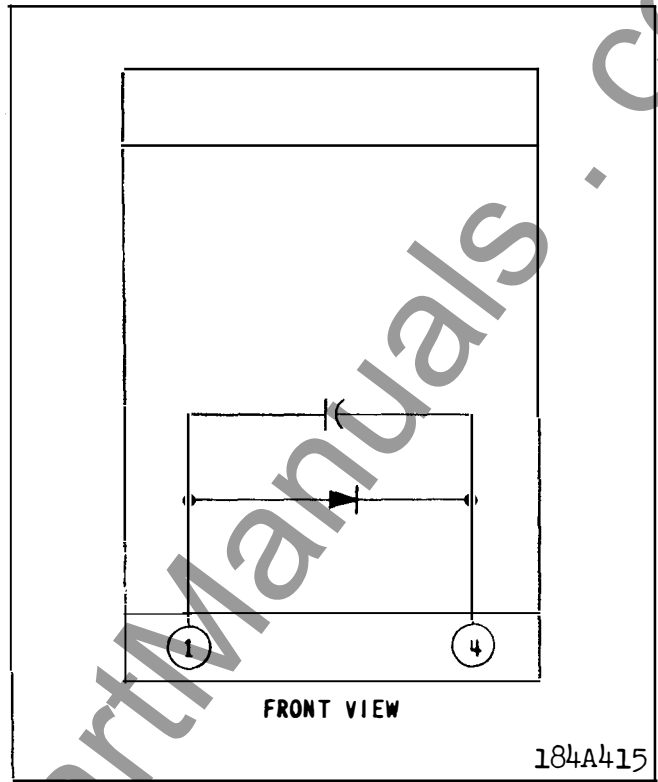
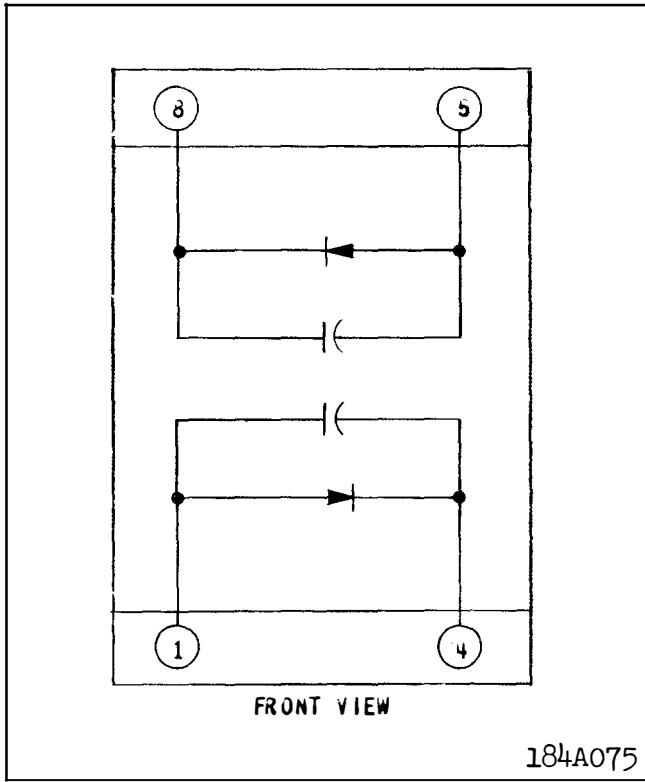

Fig. 4. Internal Schematic of Type TRB Static Tripping Unit.

Fig. 5. Internal Schematic of Type TRB-1 Blocking Valve.

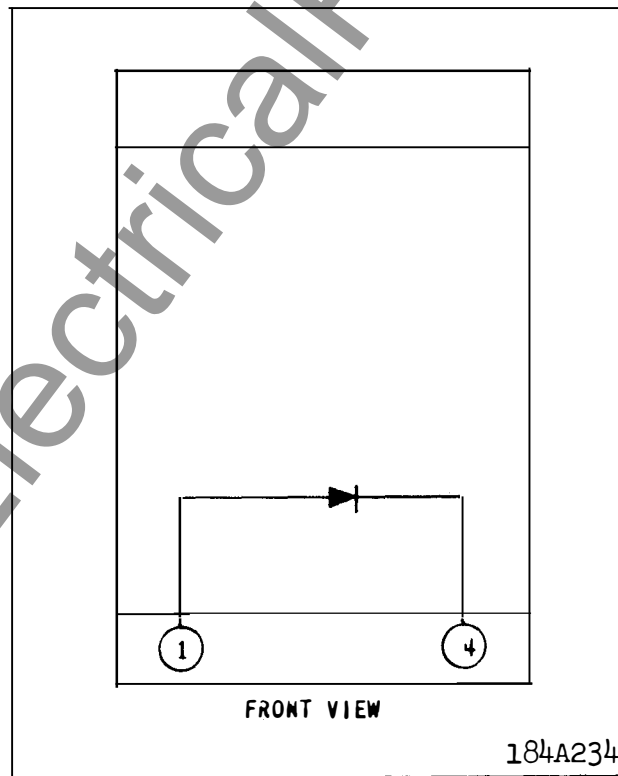

Fig. 6. Internal Schematic of Type TRB-1 Test Unit.

www.ElectricalPartManuals.com

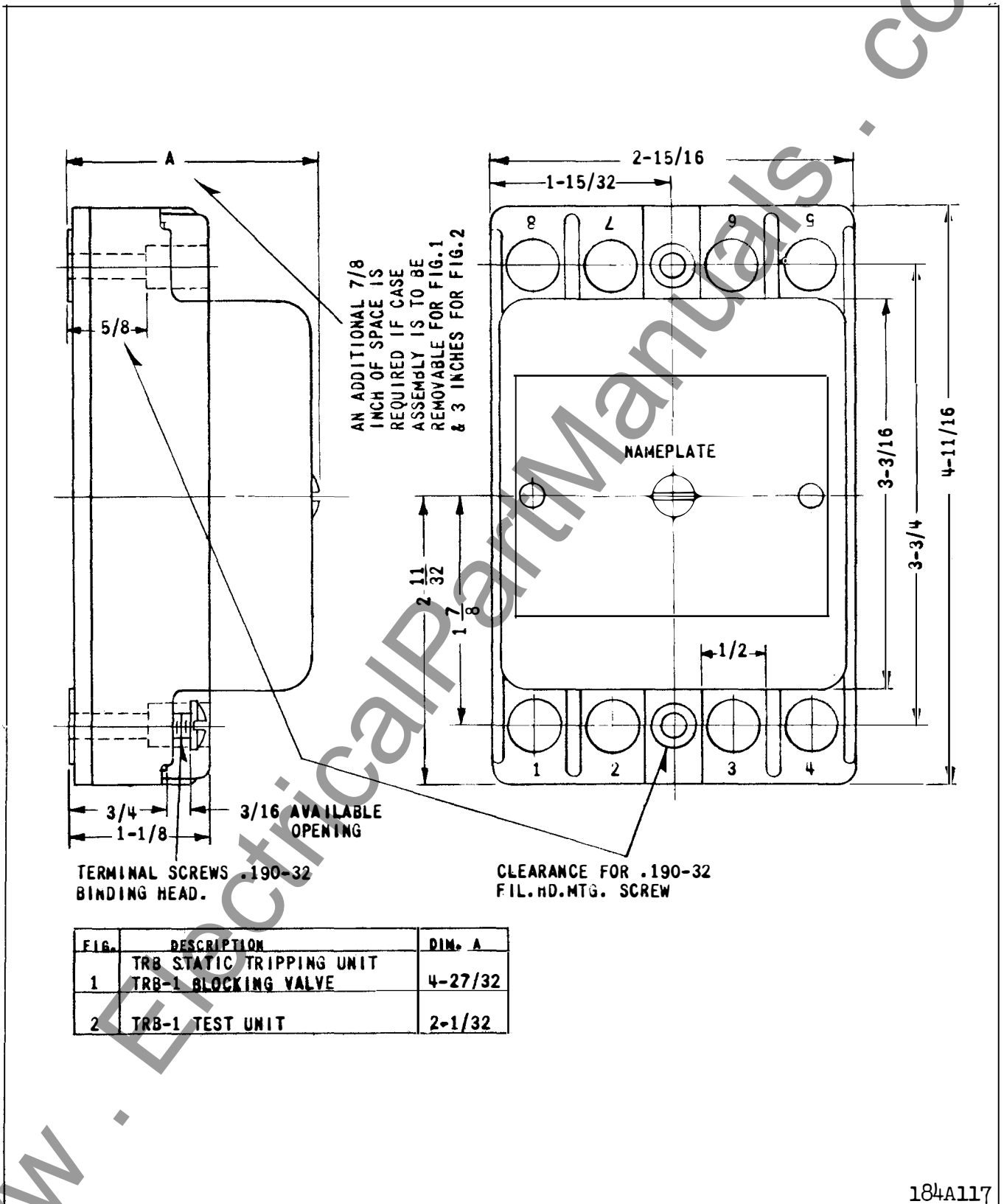

Fig. 7. Outline and Drilling Plan for Type TRB and TRB-1 Auxiliary Units.

184A117

[www.ElectricalPartManuals.com](http://www.ElectricalPartManuals.com)

[www.ElectricalPartManuals.com](http://www.ElectricalPartManuals.com)



**WESTINGHOUSE ELECTRIC CORPORATION**  
**RELAY DEPARTMENT**

**NEWARK, N. J.**

Printed in U. S. A.



**INSTALLATION • OPERATION • MAINTENANCE  
I N S T R U C T I O N S****TRB-1 BLOCKING VALVE AND  
TRB-1 TEST UNIT  
TRB-STATIC TRIPPING UNIT****PART I - TYPE TRB STATIC  
TRIPPING UNIT****APPLICATION**

The TRB static tripping unit is an auxiliary device energized by protective relays to trip circuit breakers in a double trip relaying scheme. It is suitable to cases where the total trip current of the two breakers is within the relay contact rating, usually 30 amperes. The TRB unit can also be used for isolation of multiple trip paths to one breaker.

**CONSTRUCTION AND OPERATION**

The TRB auxiliary units consists of two silicon rectifiers and two capacitors mounted in a small molded case. Each rectifier has a capacitor connected in parallel with it and each set is brought out to separate terminals.

The TRB unit is energized through the trip contacts of the protective relays of which a typical application is illustrated in Fig. 2. Contacts of relay #1 trips breaker #1, and similarly, relay #2 trips breaker #2. Relay contacts PR trips both breakers. The operation of relay #1 will energize only breaker #1. Using the TRB unit, current cannot flow from relay #1 to breaker trip coil #2 because of diode D1.

Relays associated with each particular breaker are isolated from the other breaker, yet both breakers can be tripped without additional time delay by operating a common relay.

**CHARACTERISTICS**

The TRB static tripping unit is available in two styles. One style applies to 48/125 volt D.C. service and the other is used for 250 volt D.C. applications. Specific characteristics are shown in Table I.

**PART II - TYPE TRB-1  
BLOCKING VALVE****APPLICATION**

The TRB-1 blocking valve is an auxiliary device to be used as a directional valve in a relaying scheme.

**CONSTRUCTION AND OPERATION**

The TRB-1 blocking valve consists of a single silicon rectifier and one capacitor mounted in a small molded case.

The TRB-1 unit is energized through the trip contacts of the protective relay such that trip current is allowed to flow in one direction and is blocked in the opposite direction.

**CHARACTERISTICS**

The TRB-1 blocking valve is available in two styles. One style applies to 48/125 volt D.C. service and the other is used for 250 volt D.C. applications. Specific characteristics are shown in Table I.

**PART III - TYPE TRB-1  
TEST UNIT - S#407C275G03****APPLICATION**

The primary application of the TRB-1 test unit is as a second harmonic generator for testing the harmonic restraint unit of the Types HU and HU-1 transformer differential relays.

*All possible contingencies which may arise during installation, operation, or maintenance, and all details and variations of this equipment do not purport to be covered by these instructions. If further information is desired by purchaser regarding his particular installation, operation or maintenance of his equipment, the local Westinghouse Electric Corporation representative should be contacted.*

# TYPE TRB AND TRB-1 UNITS

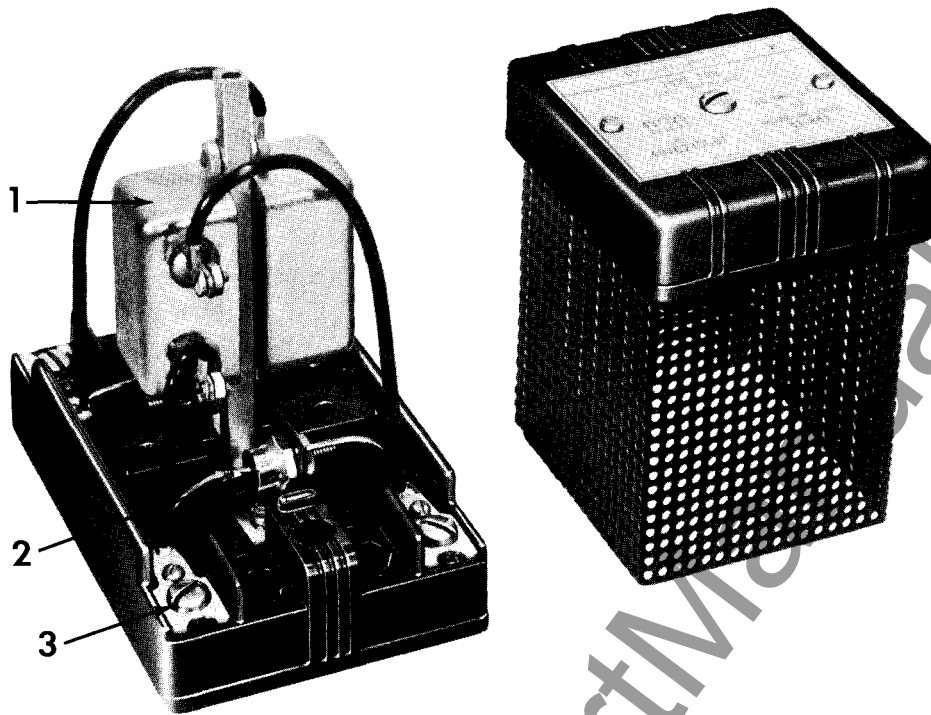

Fig. 1. Type TRB static tripping unit with cover removed. 1-Capacitor. 2-Silicon Rectifier. 3-Terminal. 4-Cover.

**TABLE I**  
**(APPLICABLE TO PART I AND PART II)**

Style & Type	Rated Circuit Volts D.C.	Rectifier Used	One Second Rating in Amperes	Maximum Volts	Rectifier Reverse Rating			Maximum Forward Voltage Drop At 30 Amperes
					Leakage Current			
					At Max. Volts		At CKT Volts	
					Nominal At 25°C	Maximum At 150°C	Nominal At 25°C	
TRB 407C275G01	48/125	304-F	30	300	2 $\mu$ A	2MA	1 $\mu$ A	1.5
TRB 407C275G02	250	304-M	30	600	2 $\mu$ A	1MA	1 $\mu$ A	1.5
TRB-I 184A414G12	48/125	304-F	30	300	2 $\mu$ A	2MA	1 $\mu$ A	1.5
TRB-I 184A414G13	250	304-M	30	600	2 $\mu$ A	1MA	1 $\mu$ A	1.5

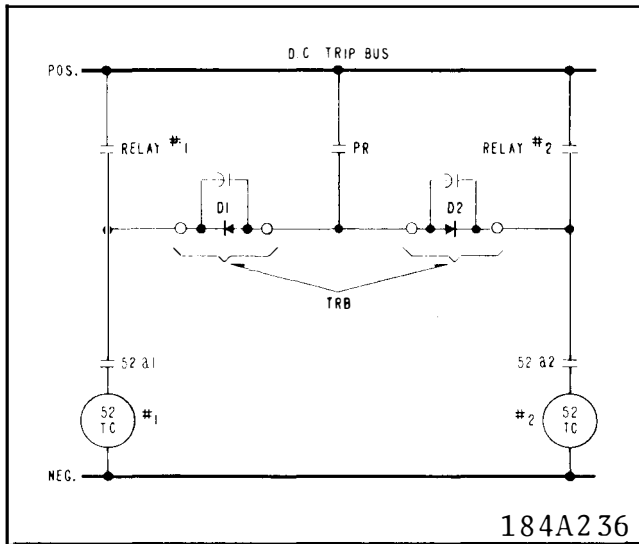

Fig. 2. Operational Schematic

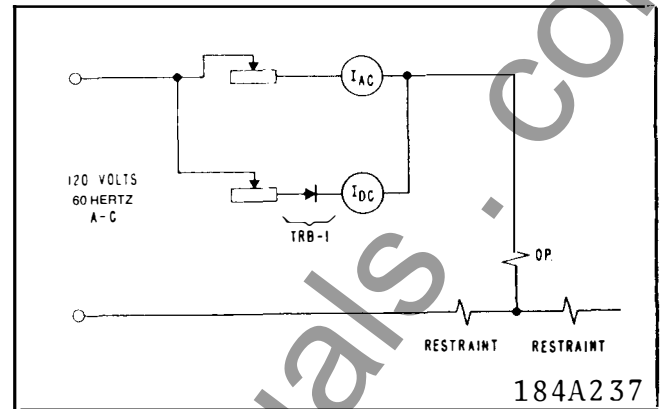

Fig. 3. Typical Test Setup of Type HU and Type HU-1 Relay using Type TRB-1 Test Unit.

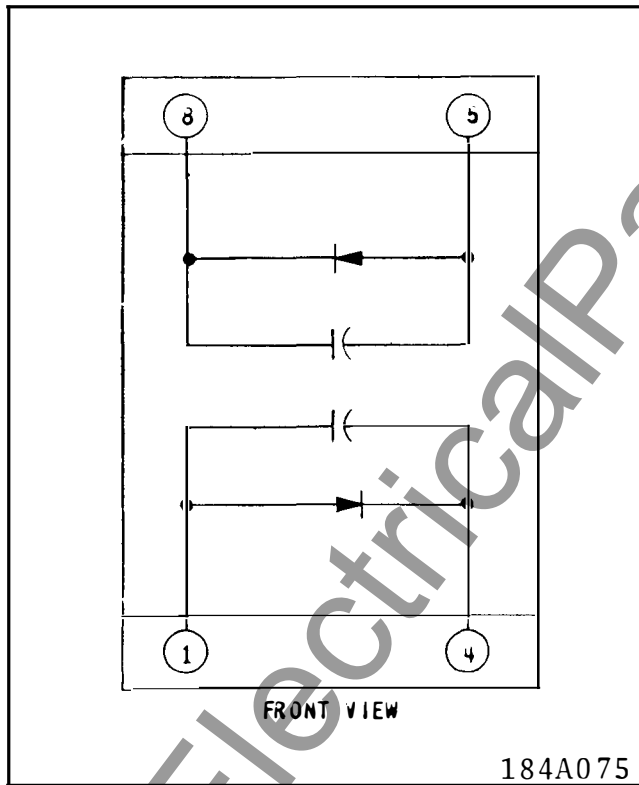

Fig. 4. Internal Schematic of Type TRB Static Tripping Unit.

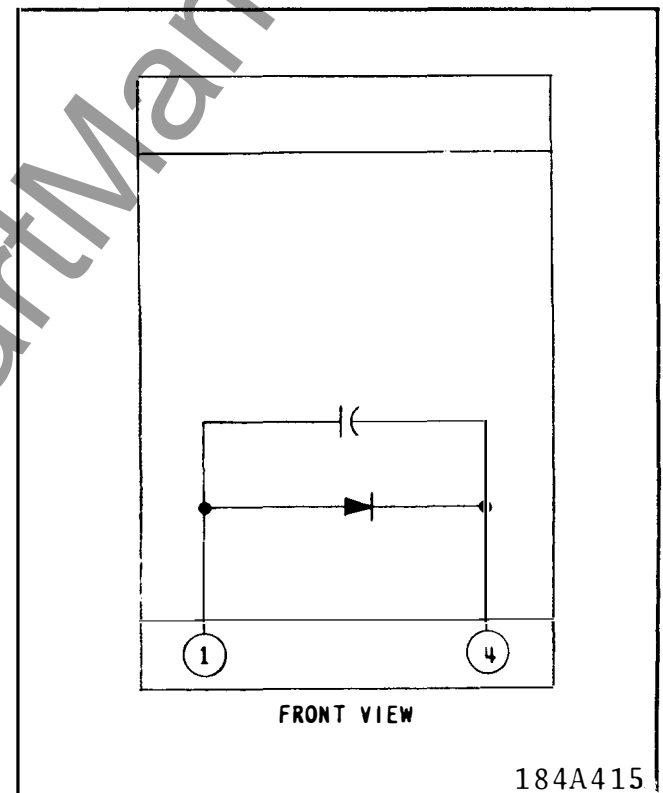

Fig. 5. Internal Schematic of Type TRB-1 Blocking Valve.

### CONSTRUCTION AND OPERATION

The TRB-1 test unit consists of a single silicon rectifier mounted in a small molded case. It is energized by an A.C. 60 hertz source as shown in Fig. 3. The half wave rectifier current from the TRB-1 combines with a 60 hertz A.C. current to produce a second harmonic wave which is in-

duced for test purposes into the harmonic restraint unit of the HU and HU-1 relays.

### CHARACTERISTICS

The TRB-1 test unit is rated for 5 amperes continuous at 120 volts 60 hertz. It uses a type 304F silicon rectifier unit which has a maximum allowable inverse voltage rating of 300 volts.

**PART IV - APPLICABLE TO BOTH TRB AND TRB-1**

**INSTALLATION**

The units should be mounted on switchboard panels or their equivalent in a location free from dirt, moisture, and heat. Mount the units by means of two mounting screws directly to the panel.

**RENEWAL PARTS**

If one of the silicon rectifier units becomes damaged, it can be removed from its mounting bracket and replaced with a new rectifier ordered by type number as given in the section titled characteristics. When soldering the connection to the rectifier, it is preferable to use entectic solder. Do not apply heat any longer than required to produce a satisfactory solder connection.

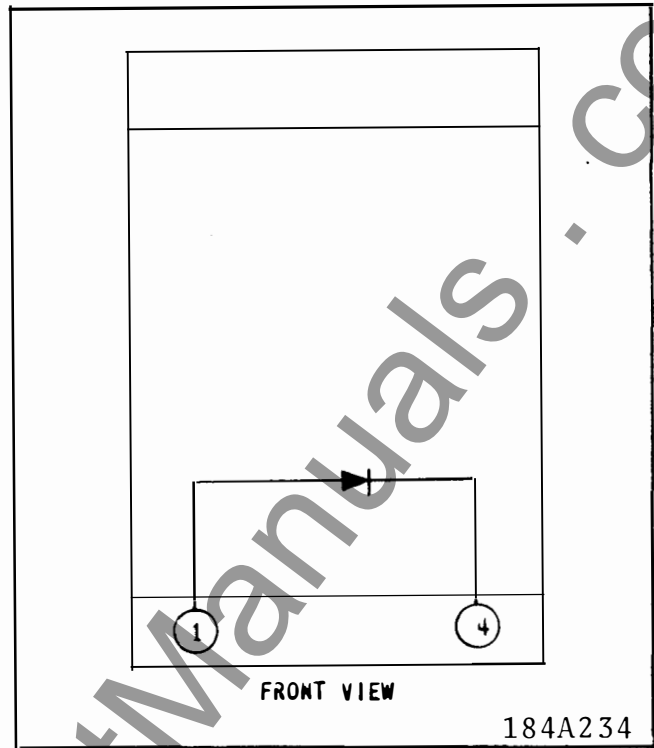

Fig. 6. Internal Schematic of Type TRB-1 Test Unit.

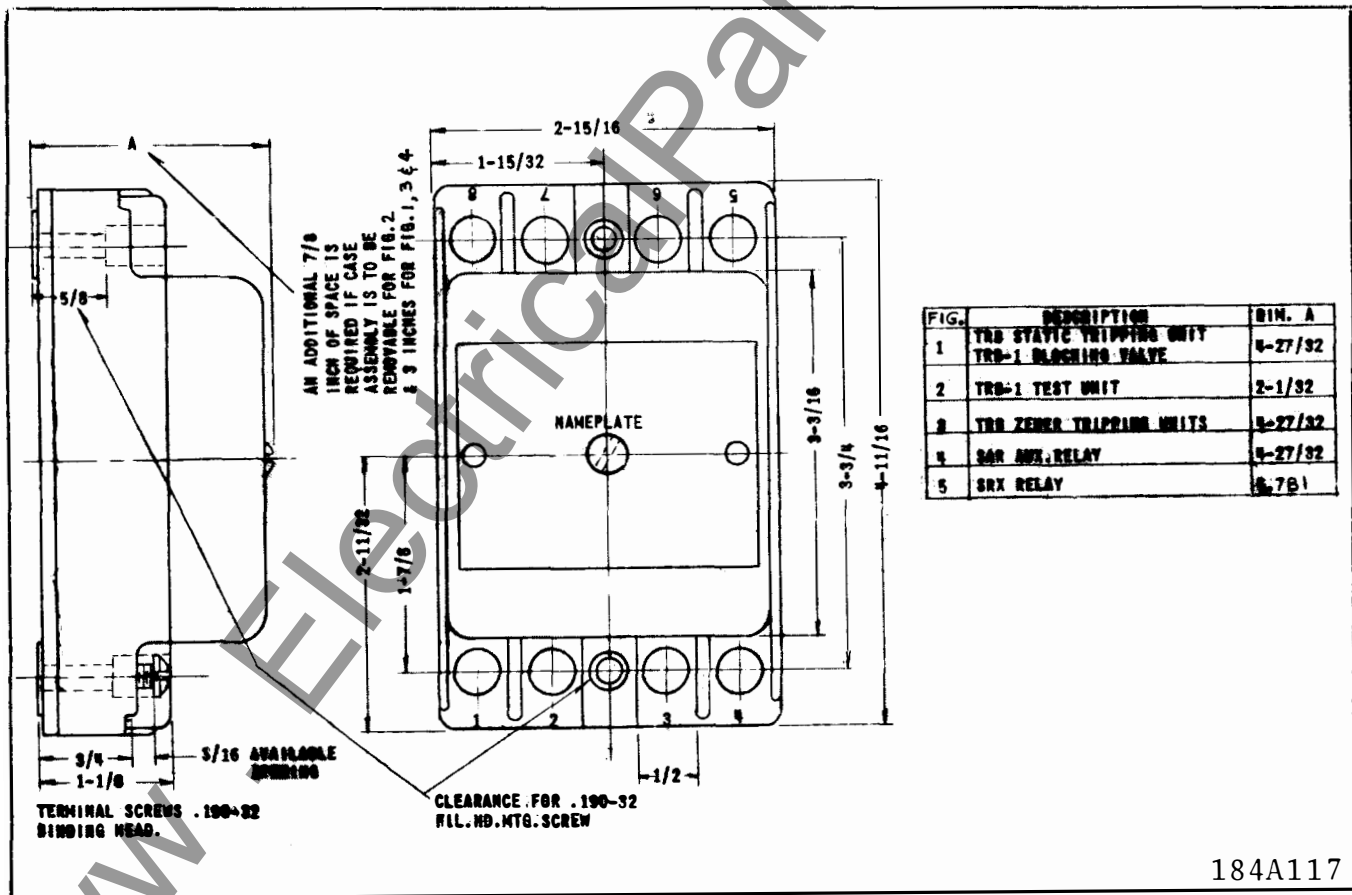

Fig. 7. Outline and Drilling Plan for Type TRB and TRB-1 Auxiliary Units.