



# DESCRIPTION • OPERATION • MAINTENANCE INSTRUCTIONS

CAT.	DESIGN N	COIL
NO.	<i>Life-Line</i> ® CONTACTOR	V CY
STYLE	SIZE 1 2, 3, 4, or 5 POLES	STYLE

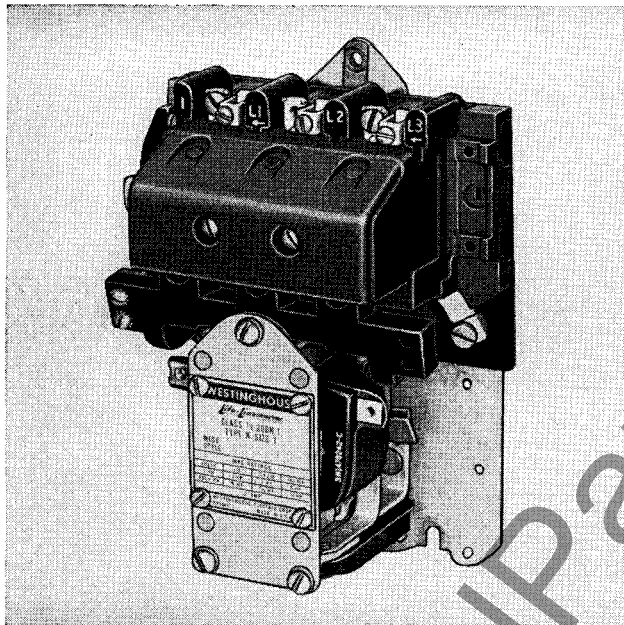

FIG. 1

**DESIGN N, LIFE-LINE® CONTACTOR**, Size 1 has been designed to be applicable to motor circuit loads, resistance loads, interconnections of multi-speed motor windings, etc. NEMA standard mounting dimensions have been met in the design of this contactor. Up to four electrical interlocks (see **ELECTRICAL INTERLOCKS**) may be mounted on each contactor depending upon circuit requirements. The contactor is complete with Line, Load and Control Terminals, STRAIGHT-THRU main wiring, and one normally open electrical interlock.

For a typical application of a single contactor showing Line, Load and Control Connections refer to Fig. 2. Customer connections are shown in dashed line. The Start and Stop pushbutton units designated are furnished separately.

For more involved controls, the user may frequently apply several contactors with interconnections to meet his particular requirements. Thus, to obtain maximum application flexibility for the user, terminal marking and control wiring have been omitted from this contactor.

### CONSTRUCTION

The Design N contactor is an inverted clapper type with knife-edge bearing and having positive action through the use of a compression kick-out spring. This construction provides maximum accessibility for servicing and maintenance and allows coil change to be a simple operation. All current carrying parts are of high conductivity copper or copper alloy of large cross section resulting in high electrical efficiency. Long life and low contact drop are assured by fine silver contacts with large area of bond for current conduction and heat transfer.

® Registered Trade-Mark

Pressure-type connectors on main and control terminals permit the use of either solid or stranded wire without soldered joints.

### ELECTRICAL INTERLOCKS

Standard contactors are furnished with one normally open interlock mounted on the lefthand side. A second interlock may be obtained by ordering either S# 453D976G05, normally open, or S# 453D976G06 normally closed. A third or fourth interlock may be obtained by ordering either S# 453D976G07 normally open, or S# 453D976G08 normally closed. The normally open interlocks may be readily installed as normally closed interlocks per instruction leaflet I. L. 11956.

A universal electrical interlock (L54) is available as an accessory. This interlock provides either NO or NC operation, or may be employed as a SPDT device jumpering the terminals on one end for a common line connection. The style number of the Type L54 interlock kit when used as a first or second interlock is S# 453D502G03; when added as the third or fourth interlock specify S# 453D502G04.

### CONTACTOR IDENTIFICATION

The LIFE-LINE CONTACTOR complete is identified by CAT. No. (shown on leaflet, carton and in catalog) or by Style NO. (shown on leaflet and carton) and consists of two basic parts: (1) The starter unit without coil, and (2) the coil.

The Cat. No. and Style No. of the starter unit (without coil) appear on the metal nameplate attached to the magnet.

The coil Style No. is marked on the coil itself along with its voltage and frequency rating.

### MAINTENANCE

The sealing surfaces on the magnet frame and armature should be kept clean.

Do not lubricate the contact tips or bearings. Fine silver contacts need no dressing throughout their life.

TO REMOVE CONTACTOR COIL, remove the three round head magnet mounting screws and withdraw the coil and magnet.

WHEN INSTALLING CONTACTOR COIL, make sure that round head magnet mounting screws are securely tightened.

### PRINCIPAL RENEWAL PARTS

2 Pole Contact Kit	S# 1605 211
3 Pole Contact Kit	S# 1605 212
4 Pole Contact Kit	2 of S# 1605 211
5 Pole Contact Kit	1 of S# 1605 211
	1 of S# 1605 212

# LIFE-LINE CONTACTOR DESIGN N

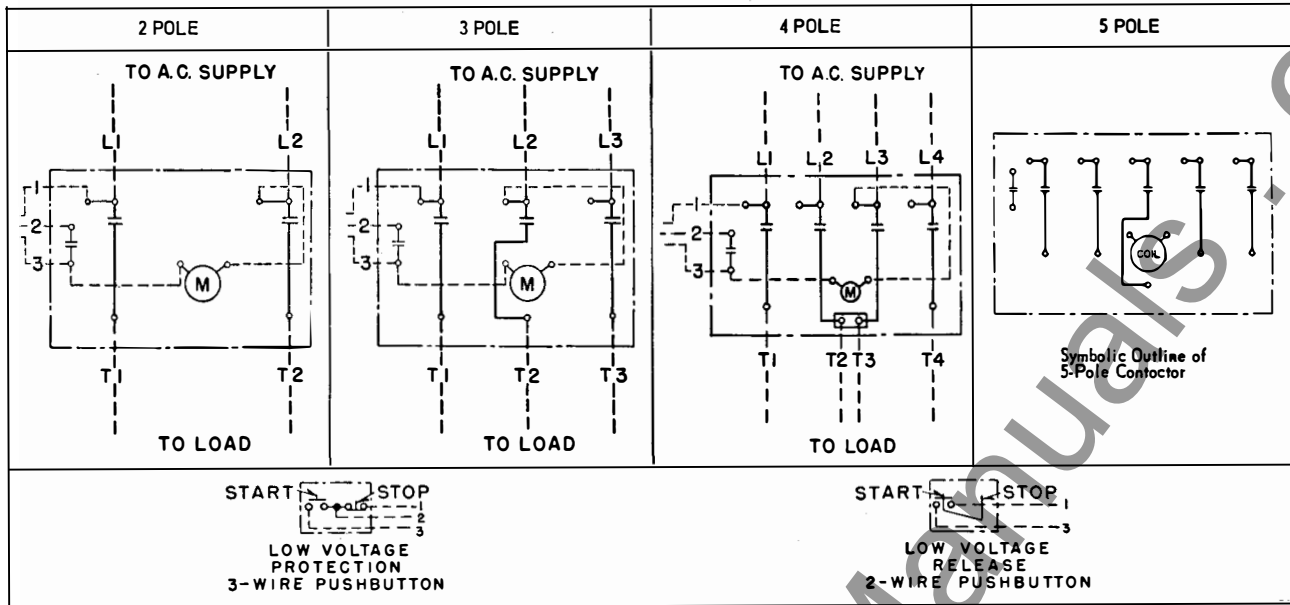

FIG. 2. Wiring Diagram

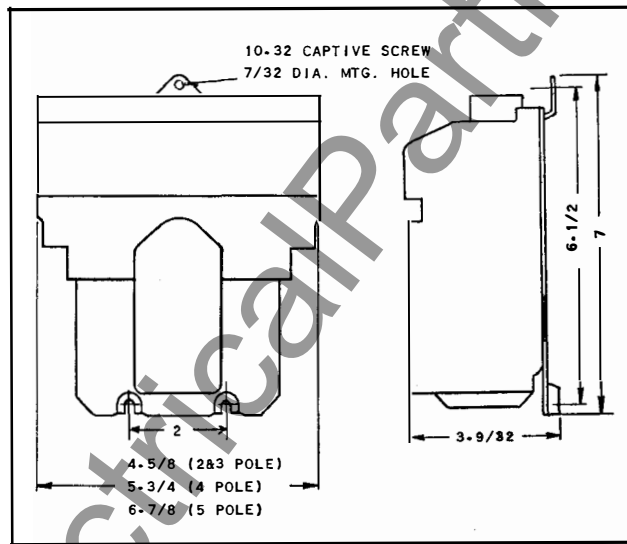

FIG. 3. Size 1—Outline



**WESTINGHOUSE ELECTRIC CORPORATION**  
**BEAVER PLANT • STANDARD CONTROL DIVISION • BEAVER, PA.**

(Rep. 2-61) Printed in U.S.A.



# DESCRIPTION • OPERATION • MAINTENANCE INSTRUCTIONS

CAT.	DESIGN N	COIL
NO.	<i>Life-Line</i> ® CONTACTOR	V CY
STYLE	SIZE 1 2, 3, 4, or 5 POLES	STYLE

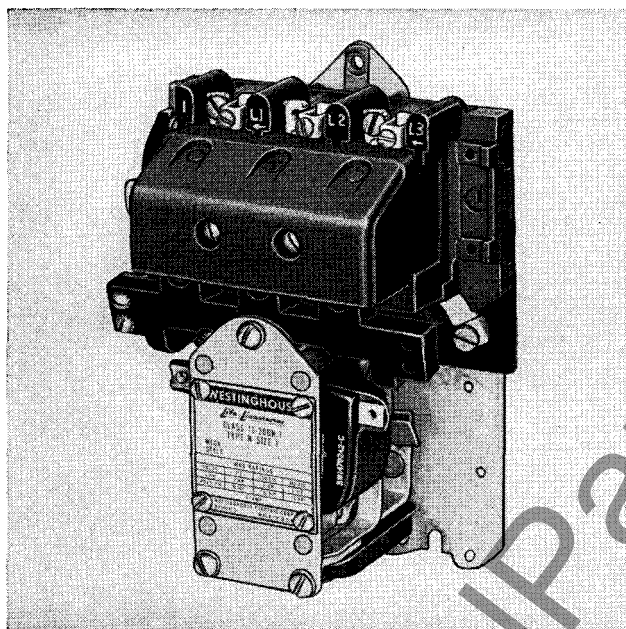

FIG. 1

**DESIGN N, LIFE-LINE® CONTACTOR, Size 1** has been designed to be applicable to motor circuit loads, resistance loads, interconnections of multi-speed motor windings, etc. NEMA standard mounting dimensions have been met in the design of this contactor. Up to four electrical interlocks (see ELECTRICAL INTERLOCKS) may be mounted on each contactor depending upon circuit requirements. The contactor is complete with Line, Load and Control Terminals, STRAIGHT-THRU main wiring, and one normally open electrical interlock.

For a typical application of a single contactor showing Line, Load and Control Connections refer to Fig. 2. Customer connections are shown in dashed line. The Start and Stop pushbutton units designated are furnished separately.

For more involved controls, the user may frequently apply several contactors with interconnections to meet his particular requirements. Thus, to obtain maximum application flexibility for the user, terminal marking and control wiring have been omitted from this contactor.

### CONSTRUCTION

The Design N contactor is an inverted clapper type with knife-edge bearing and having positive action through the use of a compression kick-out spring. This construction provides maximum accessibility for servicing and maintenance and allows coil change to be a simple operation. All current carrying parts are of high conductivity copper or copper alloy of large cross section resulting in high electrical efficiency. Long life and low contact drop are assured by fine silver contacts with large area of bond for current conduction and heat transfer.

® Registered Trade-Mark

Pressure-type connectors on main and control terminals permit the use of either solid or stranded wire without soldered joints.

### ELECTRICAL INTERLOCKS

Standard contactors are furnished with one normally open interlock mounted on the lefthand side. A second interlock may be obtained by ordering either S# 453D976G05, normally open, or S# 453D976G06 normally closed. A third or fourth interlock may be obtained by ordering either S# 453D976G07 normally open, or S# 453D976G08 normally closed. The normally open interlocks may be readily installed as normally closed interlocks per instruction leaflet I. L. 11956.

A universal electrical interlock (L54) is available as an accessory. This interlock provides either NO or NC operation, or may be employed as a SPDT device jumpering the terminals on one end for a common line connection. The style number of the Type L54 interlock kit when used as a first or second interlock is S# 453D502G03; when added as the third or fourth interlock specify S# 453D502G04.

### CONTACTOR IDENTIFICATION

The LIFE-LINE CONTACTOR complete is identified by CAT. No. (shown on leaflet, carton and in catalog) or by Style NO. (shown on leaflet and carton) and consists of two basic parts: (1) The starter unit without coil, and (2) the coil.

The Cat. No. and Style No. of the starter unit (without coil) appear on the metal nameplate attached to the magnet.

The coil Style No. is marked on the coil itself along with its voltage and frequency rating.

### MAINTENANCE

The sealing surfaces on the magnet frame and armature should be kept clean.

Do not lubricate the contact tips or bearings. Fine silver contacts need no dressing throughout their life.

TO REMOVE CONTACTOR COIL, remove the three round head magnet mounting screws and withdraw the coil and magnet.

WHEN INSTALLING CONTACTOR COIL, make sure that round head magnet mounting screws are securely tightened.

### PRINCIPAL RENEWAL PARTS

2 Pole Contact Kit.....	S# 1605 211
3 Pole Contact Kit.....	S# 1605 212
4 Pole Contact Kit.....	2 of S# 1605 211
5 Pole Contact Kit.....	{ 1 of S# 1605 211
	{ 1 of S# 1605 212

# LIFE-LINE CONTACTOR DESIGN N

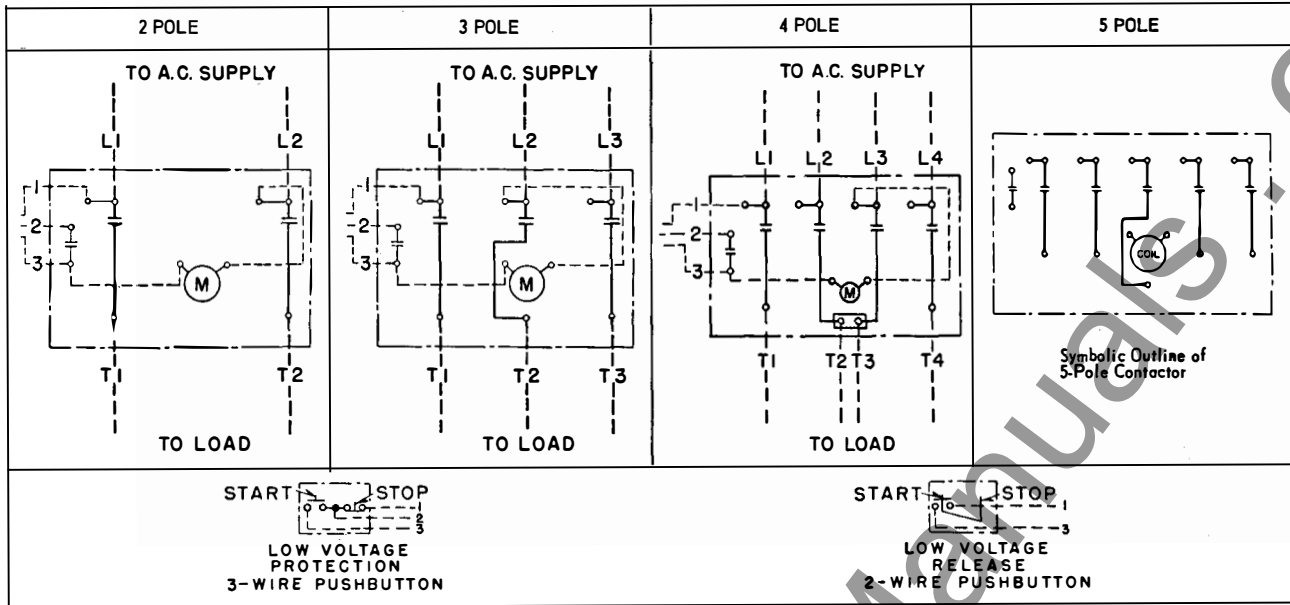

FIG. 2. Wiring Diagram

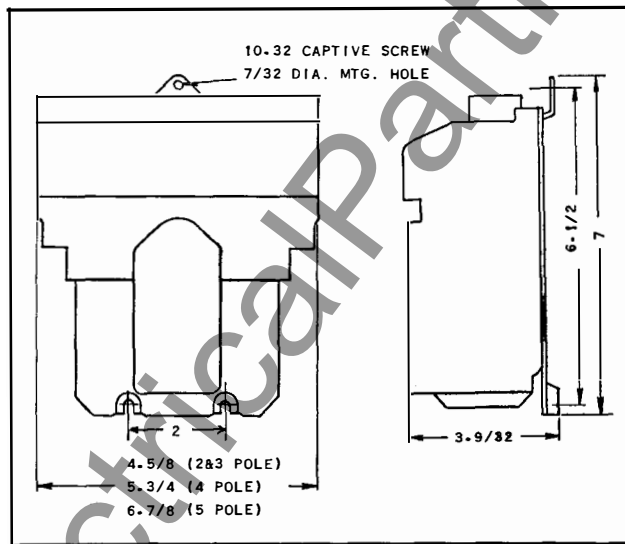

FIG. 3. Size 1—Outline



**WESTINGHOUSE ELECTRIC CORPORATION**  
**BEAVER PLANT • STANDARD CONTROL DIVISION • BEAVER, PA.**



# DESCRIPTION • OPERATION • MAINTENANCE INSTRUCTIONS

CAT. NO.	DESIGN N	COIL V	CY
STYLE	<i>Life-Line</i> ® CONTACTOR SIZE 1 2, 3, 4, or 5 POLES STYLE		

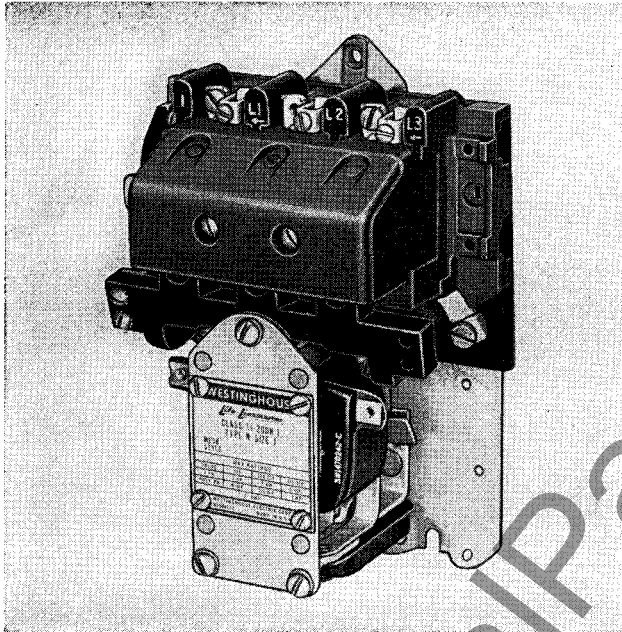

FIG. 1

**DESIGN N, LIFE-LINE® CONTACTOR**, Size 1 has been designed to be applicable to motor circuit loads, resistance loads, interconnections of multi-speed motor windings, etc. NEMA standard mounting dimensions have been met in the design of this contactor. Up to four electrical interlocks (see **ELECTRICAL INTERLOCKS**) may be mounted on each contactor depending upon circuit requirements. The contactor is complete with Line, Load and Control Terminals, STRAIGHT-THRU main wiring, and one normally open electrical interlock.

For a typical application of a single contactor showing Line, Load and Control Connections refer to Fig. 2. Customer connections are shown in dashed line. The Start and Stop pushbutton units designated are furnished separately.

For more involved controls, the user may frequently apply several contactors with interconnections to meet his particular requirements. Thus, to obtain maximum application flexibility for the user, terminal marking and control wiring have been omitted from this contactor.

## CONSTRUCTION

The Design N contactor is an inverted clapper type with knife-edge bearing and having positive action through the use of a compression kick-out spring. This construction provides maximum accessibility for servicing and maintenance and allows coil change to be a simple operation. All current carrying parts are of high conductivity copper or copper alloy of large cross section resulting in high electrical efficiency. Long life and low contact drop are assured by fine silver contacts with large area of bond for current conduction and heat transfer.

® Registered Trade-Mark

Pressure-type connectors on main and control terminals permit the use of either solid or stranded wire without soldered joints.

## ELECTRICAL INTERLOCKS

Standard contactors are furnished with one normally open interlock mounted on the lefthand side. A second interlock may be obtained by ordering either S# 453D976G05, normally open, or S# 453D976G06 normally closed. A third or fourth interlock may be obtained by ordering either S# 453D976G07 normally open, or S# 453D976G08 normally closed. The normally open interlocks may be readily installed as normally closed interlocks per instruction leaflet I. L. 11956.

A universal electrical interlock (L54) is available as an accessory. This interlock provides either NO or NC operation, or may be employed as a SPDT device jumpering the terminals on one end for a common line connection. The style number of the Type L54 interlock kit when used as a first or second interlock is S# 453D502G03; when added as the third or fourth interlock specify S# 453D502G04.

## CONTACTOR IDENTIFICATION

The LIFE-LINE CONTACTOR complete is identified by CAT.No. (shown on leaflet, carton and in catalog) or by Style NO. (shown on leaflet and carton) and consists of two basic parts: (1) The starter unit without coil, and (2) the coil.

The Cat. No. and Style No. of the starter unit (without coil) appear on the metal nameplate attached to the magnet.

The coil Style No. is marked on the coil itself along with its voltage and frequency rating.

## MAINTENANCE

The sealing surfaces on the magnet frame and armature should be kept clean.

Do not lubricate the contact tips or bearings. Fine silver contacts need no dressing throughout their life.

TO REMOVE CONTACTOR COIL, remove the three round head magnet mounting screws and withdraw the coil and magnet.

WHEN INSTALLING CONTACTOR COIL, make sure that round head magnet mounting screws are securely tightened.

## PRINCIPAL RENEWAL PARTS

2 Pole Contact Kit.....	S# 1605 211
3 Pole Contact Kit.....	S# 1605 212
4 Pole Contact Kit.....	2 of S# 1605 211
5 Pole Contact Kit.....	{ 1 of S# 1605 211 1 of S# 1605 212

# LIFE-LINE CONTACTOR DESIGN N

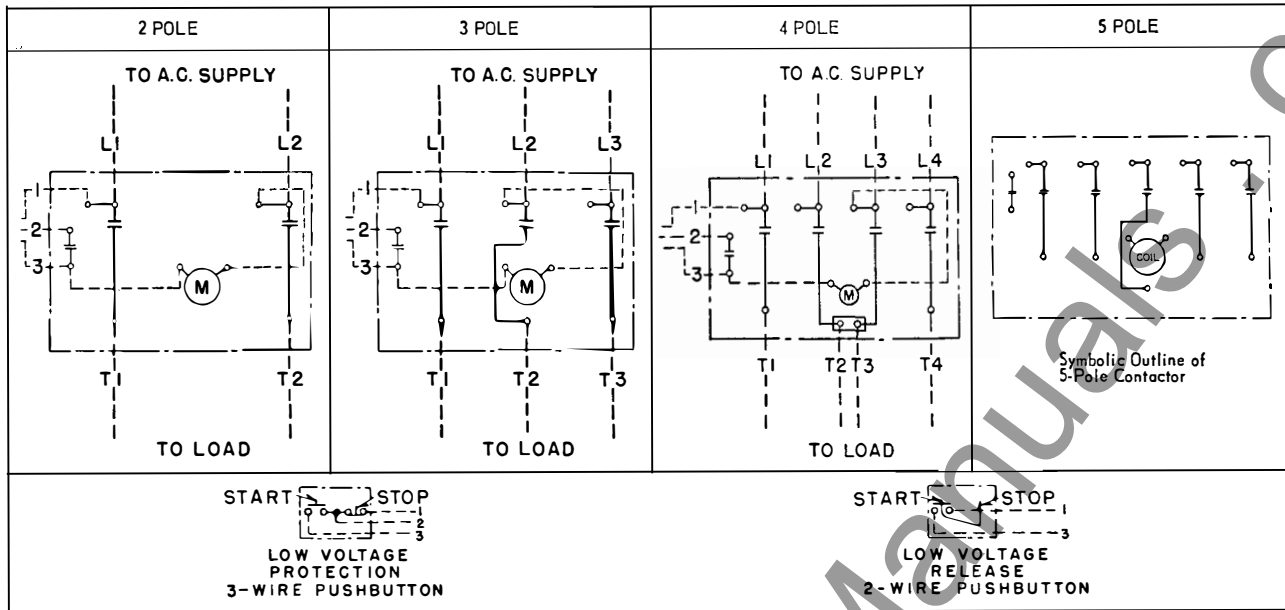

FIG. 2. Wiring Diagram

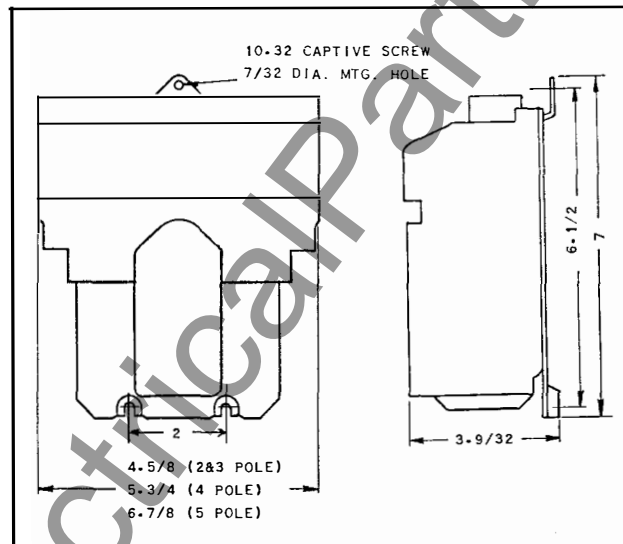

FIG. 3. Size 1—Outline