

Circuit Breaker
Interrupor
Disjoncteur





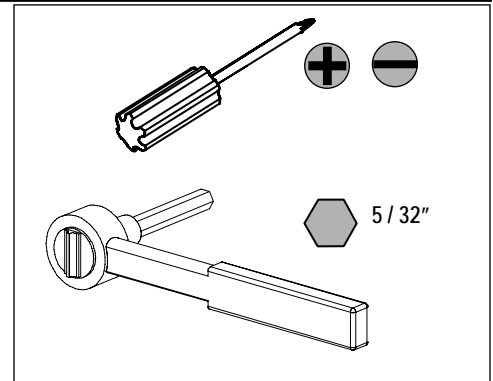

For Use With Frame EB
Para Usar Con Caja Base EB

Installation Instructions / Instructivo de Instalación

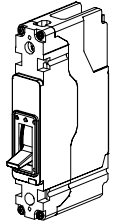
	⚠ Danger	⚠ Peligro	⚠ Danger
	Hazardous Voltage. Will cause death or serious injury.	Tensión peligrosa. Puede causar la muerte o lesiones graves.	Tension dangereuse. Danger de mort ou risque de blessures graves.
	Turn off and lock out all power supplying this device before working on this device. Replace all covers before power supplying this device is turned on.	Desenergice totalmente antes de instalar o darle servicio. Reemplace todas las barreras y cubiertas antes de energizar el interruptor.	Couper l'alimentation de l'appareil et barrer avant de travailler. Remplacez tous les couverts avant que l'alimentation de pouvoir soit alimenté.

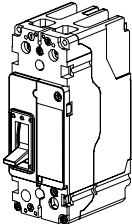
Use only with Siemens certified components.
Utilizar únicamente con componentes certificados de Siemens.
A utiliser uniquement avec les composants certifiés Siemens.

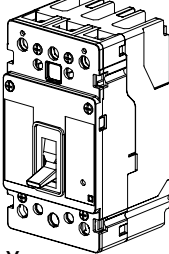

<p>1 Pole / Polos</p>  <p>6 - 32 X 2.75 in. [70]</p>  <p>Frame - EB Caja Base - EB</p>	<p>2 Pole / Polos</p>  <p>2 X 6 - 32 X 2.75 in. [70]</p> <p>2 X </p> <p>Frame - EB Caja Base - EB</p>	<p>3 Pole / 3 Polos</p>  <p>2 X 6 - 32 X 2.75 in. [70]</p> <p></p> <p>Frame - EB Caja Base - EB</p>
--	---	---

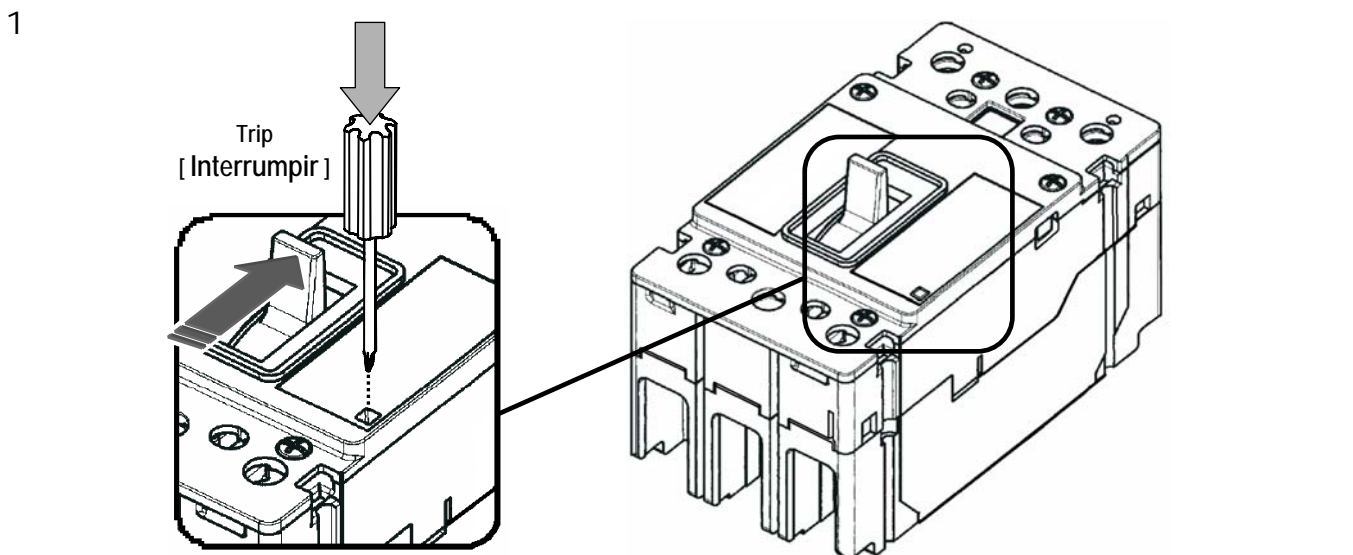

2

2 X 1 Pole / Polos

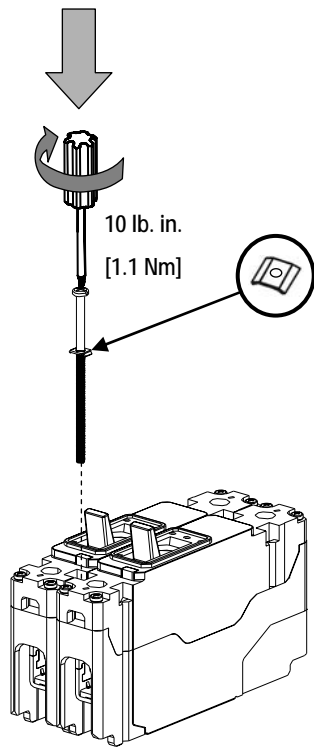

3

2 Pole / Polos

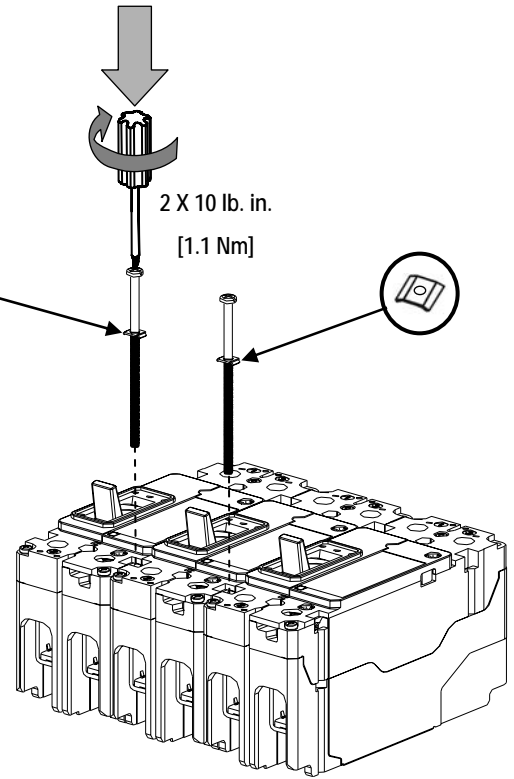
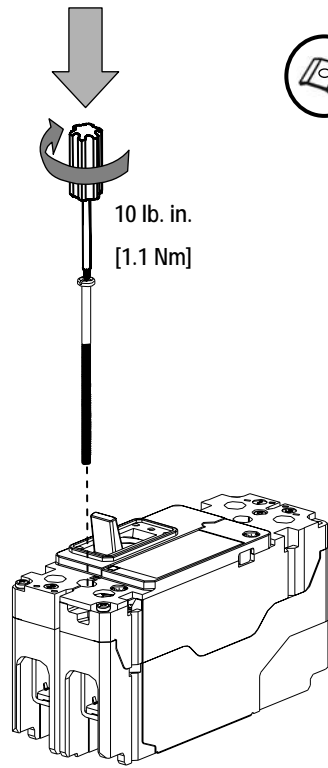

4

3 Pole / Polos

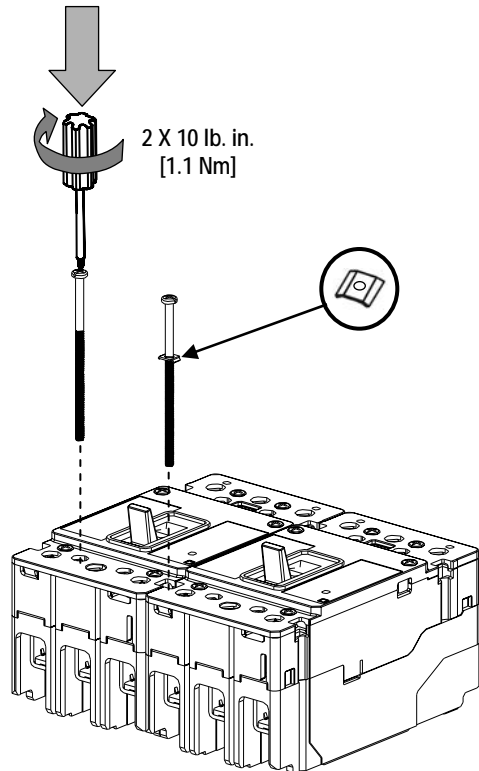
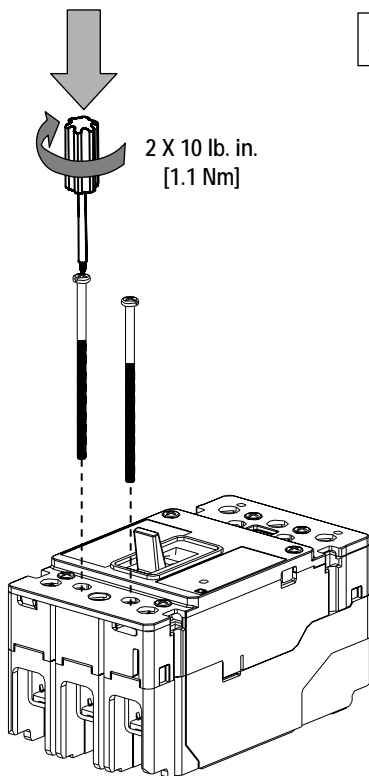

 	<p>Danger</p> <p>Hazardous Voltage. Will cause death or serious injury.</p> <p>Turn off and lock out all power supplying this device before working on this device. Replace all covers before power supplying this device is turned on.</p>	<p>Peligro</p> <p>Tensión peligrosa. Puede causar la muerte o lesiones graves.</p> <p>Desenergice totalmente antes de instalar o darle servicio. Reemplace todas las barreras y cubiertas antes de energizar el interruptor.</p>	<p>Danger</p> <p>Tension dangereuse. Danger de mort ou risque de blessures graves.</p> <p>Couper l'alimentation de l'appareil et barrer avant de travailler. Remplacez tous les couverts avant que l'alimentation de pouvoir soit alimenté.</p>
--	--	---	--

5

NOTICE:

FOR MOUNTING OF BREAKERS IN EQUIPMENT, REFER TO THE ORIGINAL EQUIPMENT MANUFACTURER'S REQUIREMENTS AND SPECIFICATIONS.

[PARA EL MONTAJE DE LOS INTERRUPTORES EN EL EQUIPO, REFIERASE A LOS REQUISITOS Y ESPECIFICACIONES ORIGINALES DEL FABRICANTE DEL EQUIPO]

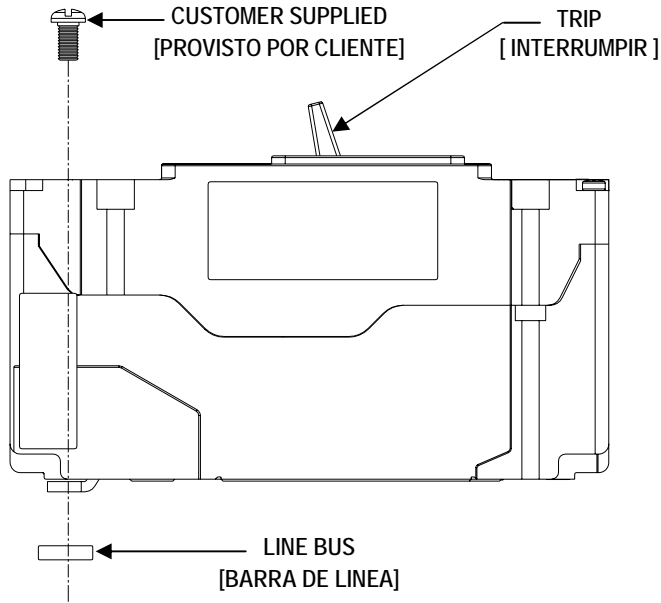

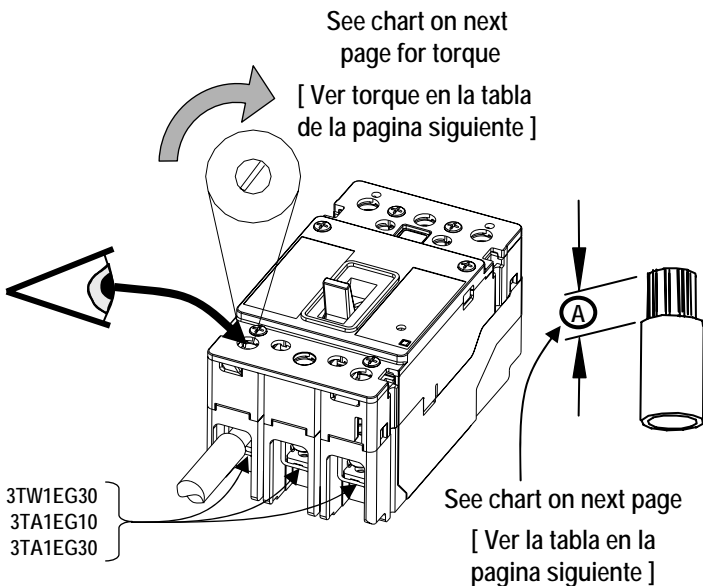

6

Option 1
[Opción 1]

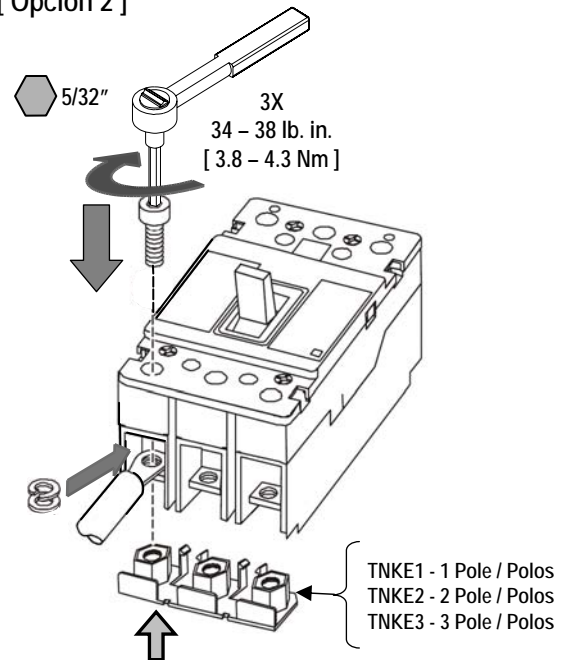

Option 2
[Opción 2]

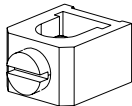
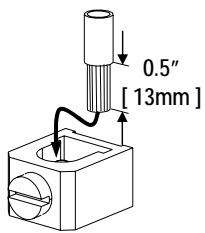
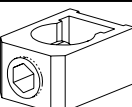
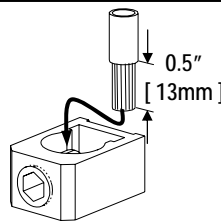
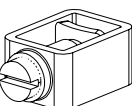

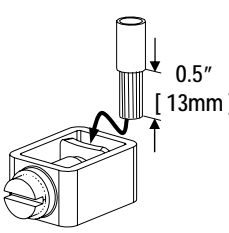
Wire Connector [Conexión del cable]	Wire Size [Rango Cable]	Req. Wire Stranding [Hebras] UL 486A - 486B		Torque [esfuerzo de torsión]	Wire Strip Length [Quitar]	
		CU / AL Class B	CU Class C			
					(A)	
 3TA1EG10 (Cu / Al) STANDARD 15-100A	14 - 10 AWG [2.5 - 6 mm ²]	7	19	35 Lb. in. [4.0 Nm]	0.5" [13mm]	
	8 AWG [10 mm ²]			40 Lb. in. [4.5 Nm]		
	6 - 4 AWG [16 - 25 mm ²]			45 Lb. in. [5.1 Nm]		
	3 - 2 AWG [35 mm ²]			50 Lb. in. [5.6 Nm]		
	1 - 1 / 0 AWG [50 mm ²]	19	37	50 Lb. in. [5.6 Nm]		
 3TA1EG30 (Cu / Al) STANDARD 110-125A	6 - 2 AWG [16 - 35 mm ²]	7	19	80 Lb. in. [9.0 Nm]	0.5" [13mm]	
	1 - 3 / 0 AWG [50 - 95 mm ²]	19	37			
 3TW1EG30 (Cu Only) OPTIONAL	14 - 10 AWG [2.5 - 6 mm ²]		19	35 Lb. in. [4.0 Nm]	0.5" [13mm]	
	8 AWG [10 mm ²]			40 Lb. in. [4.5 Nm]		
	6 - 4 AWG [16 - 25 mm ²]			45 Lb. in. [5.1 Nm]		
	3 - 2 AWG [35 mm ²]			50 Lb. in. [5.6 Nm]		
	1 - 3 / 0 AWG [50 - 95 mm ²]		37	50 Lb. in. [5.6 Nm]		

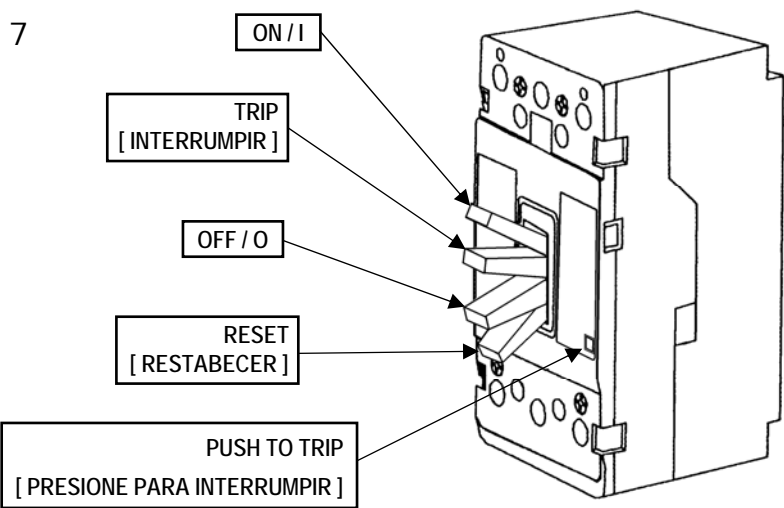

Note: If cover must be removed for accessory installation, torque cover mounting screws to 10-13 Lb.in. [1.1-1.5 Nm].

[Nota: Si la cubierta se debe quitar por cualquier razón, los tornillos de montaje de la cubierta requieren esfuerzo de torsión de 10 - 13 Lb. in. (1.1 - 1.5 Nm)]