

SIEMENS-ALLIS

Installation • Operation • Maintenance

Instructions

**LimiTrip Overcurrent
Trip Devices Used
With Type LA
Power Circuit Breakers
SG3108**

CONTENTS

TABLE OF CONTENTS

Introduction		Secondary Current Testing	8
Field Service Operation		Testing Without a Portable Test Set	9
Warranty		Test Connections	10
Description		Long Time Pick-Up Test	10
General	1	Short Time Pick-Up Test	10
Sensor Transformers	1	Instantaneous Trip Test	11
LimiTrip Trip Device	1	Long Time Delay Test	11
Tripping Actuator	1	Short Time Delay Test	11
Removing LimiTrip From the Breaker	2	Tripping Actuator Test	11
Available Types	2	Sensor Transformer Tests	12
Time-Current Curves	2	Continuity Check	12
Performance in Service	3	Excitation Test	12
		Primary Current Testing	13
Settings		Repair	15
LimiTrip Settings	5		
Time Bands	7	Maintenance	
Testing		Cleaning	16
General	8		

ILLUSTRATIONS

Figure 1.	LimiTrip Static Trip Devices	Contents
Figure 2.	Breaker Rating Plate	1
Figure 3.	Tripping Actuator	1
Figure 4.	Breaker Wiring for Types LTI, LTS, and LTSI	3
Figure 5.	Time-Current Curves	4
Figure 6.	Calibrated Settings	6
Figure 7.	LimiTrip Rating Table	7
Figure 8.	Testing With Portable Test Set	8
Figure 9.	Testing With Portable Test Set, Connection Diagram	9
Figure 10.	Secondary Testing Without Test Set	10
Figure 11.	Primary Current Testing	14
Figure 12.	LimiTrip — Cover Open	16

The information contained within is intended to assist operating personnel by providing information on the general characteristics of equipment of this type. It does not relieve the user of responsibility to use sound engineering practices in the installation, application, operation and maintenance of the particular equipment purchased.

If drawings or other supplementary instructions for specific applications are forwarded with this manual or separately, they take precedence over any conflicting or incomplete information in this manual.

CONTENTS

INTRODUCTION

This instruction manual contains descriptive, operating, testing and maintenance information for LimiTrip overcurrent trip devices, which are shown in Figure 1. LimiTrip devices are used with 600-volt class, Type LA low voltage power circuit breakers.

FIELD SERVICE OPERATION

Siemens-Allis can provide competent, well-trained Field Service Representatives to provide technical guidance

and advisory assistance for the installation, overhaul, repair and maintenance of Siemens-Allis equipment, processes and systems. Contact regional service centers, sales offices or factory for details.

WARRANTY

The sales contract carries all information on warranty coverage.

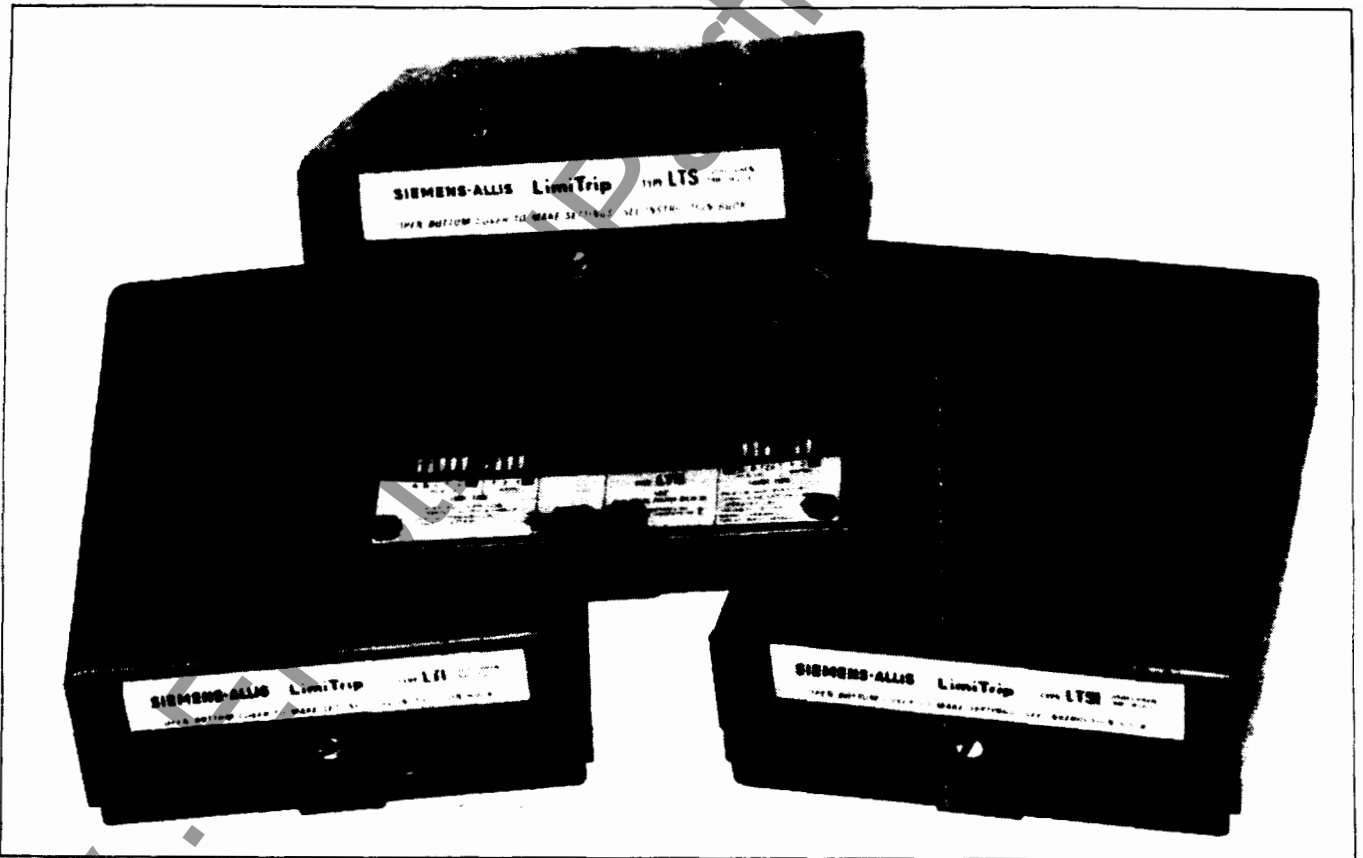

Figure 1. LimiTrip Overcurrent Trip Devices

DESCRIPTION

GENERAL

LimiTrip overcurrent trip devices are completely static — with exception of the selector switches, there are no moving parts or contacts. Components used are semi-conductors, integrated circuits, capacitors, etc. The circuits are designed for conservative loading of components for long life and little maintenance.

LimiTrip overcurrent trip devices operate to open the circuit breaker when the circuit current exceeds a pre-selected current-time relationship. Depending on the magnitude of the overcurrent and the selected settings, tripping may be instantaneous or time-delayed.

Energy to operate the tripping system is obtained solely from the circuit being protected. Batteries or other power sources are not needed.

The complete overcurrent trip system consists of three parts — (1) primary circuit tripping (sensor) transformers (2) the LimiTrip device (3) a magnetically held circuit breaker latch release device called the tripping actuator.

SERIAL NO. _____
DATE MFG. _____
Voltage _____, MTR. _____ CLO. _____
TRP. _____, TRIP XFMR _____ /1A.
WIRED PER _____
LONG TIME PICKUP IN AMPERES
A _____ B _____ C _____ D _____
E _____ F _____
MAX. CONT. CURRENT _____ AMPS
SIEMENS-ALLIS Made in U.S.A.

Figure 2. Circuit Breaker Rating Plate

TRIPPING (SENSOR) TRANSFORMERS

Toroidal current sensor transformers are mounted, one-per-phase on the primary studs of the circuit breaker. Also called tripping transformers, they provide the signal and power to the static trip device proportional to the primary current. The power transformers are saturating units that deliver an output pulse at each "zero" crossing of the cur-

rent wave. The sensor transformers selected for a specific circuit breaker establish the maximum continuous current rating of that breaker and the adjustment range. Each transformer provides a choice of six continuous current settings which are listed on the breaker rating plate (Figure 2). The highest setting is 2-1/4 times the lowest setting.

LIMITRIP TRIP DEVICE

A metal enclosure, attached to the breaker, houses the trip device and its electronic circuits. The LimiTrip device receives the signals from the sensor transformers. It monitors the signal, senses overloads and faults, and determines the required action in accordance with preselected switch settings. The switches are located inside the metal enclosure and are accessible by opening the bottom cover.

TRIPPING ACTUATOR

When the LimiTrip device senses a circuit condition that requires the circuit breaker to open, it produces an output that is fed to the tripping actuator. The actuator then causes the circuit breaker contacts to open and isolate the circuit.

Mounted on the circuit breaker, the tripping actuator is held in a charged position by a permanent magnet. It contains a coil that is energized by the output of the static trip device. When energized, the coil causes the magnetic flux to shift to a new path, releasing the stored energy of a spring located inside the tripping actuator. The spring provides the energy to trip the breaker. See Figure 3.

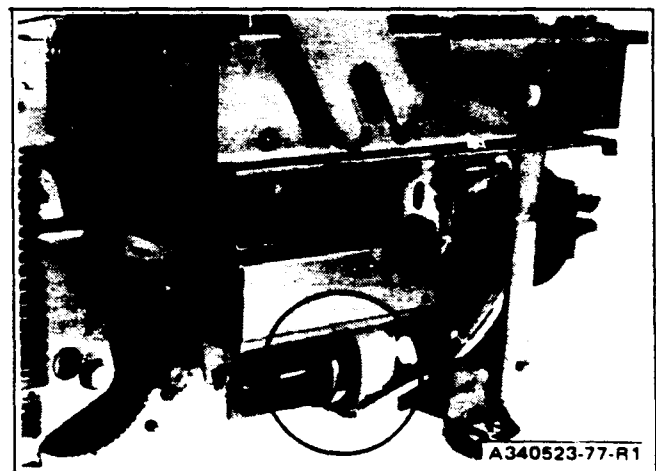

Figure 3. Tripping Actuator

DESCRIPTION

REMOVING AND RE-INSTALLING THE LIMITRIP

LimiTrip units can be removed from the circuit breaker for replacement or for bench testing.

1. Remove the breaker from the cubicle.
2. Disconnect 12 wires from current sensing transformers on rear of breaker. Release any wire harness anchors so that wire can be removed with LimiTrip device. Disconnect red and black wires from actuator.
3. Remove the one screw just above the LimiTrip face plate and slide the LimiTrip unit out by pulling it toward you.
4. To install a unit, reverse steps 1-3. Connect one yellow wire to each "Y" terminal on the transformers. Connect the orange lead to all three "O" terminals jumpered together. Connect one blue lead to each "B" terminal on the transformers. Connect one green lead to each "G" terminal on the transformers. Be sure to tighten all screws.

AVAILABLE TYPES

The type designation is coded to indicate the functional elements: L = LimiTrip, T = LONG-TIME delay element, S = SHORT-TIME delay element, I = INSTANTANEOUS element. For each element except INSTANTANEOUS there are two adjustment switches in the device, one for pick-up setting and one for delay setting. The instantaneous element has only one switch for pick-up setting. See Figure 9. Following are brief descriptions of the three types:

Three types of LimiTrip devices are available. Similar in many respects, they differ only in their specific application. All use identical tripping transformer inputs and provide output signals to the tripping actuator. The three types are shown in Figure 1.

TYPE LTI — A dual trip device normally used for phase overcurrent protection. The long time pick-up range is selected from the trip rating table and is selectable from "A" thru "F" in the field. The instantaneous element is field selectable at 3, 6, 8, and 12 multiples of the long time pick-up setting selected. The long time delay is field selectable

with a choice of four bands.

TYPE LTS (optional) — A selective trip device used for phase overcurrent protection which provides time delay tripping only. It allows field selection of the long time band and pick-up plus the short time band and pick-up. The short time pick-up can be set at 3, 6, 8, and 12 multiples of the long time pick-up setting. Any one of the three short time bands can be chosen to be used with any of the four long time bands.

TYPE LTSI (optional) — A triple selective trip device used for phase overcurrent protection which provides long time delay, short time delay, and instantaneous elements. It allows complete field selection of the long time band and pick-up, the short time band and pick-up and the instantaneous pick-up. Both the short time and instantaneous elements can be set to pick up at 3, 6, 8, or 12 multiples of the long time pick-up setting. Any one of the three short time bands can be chosen to be used with any of the four long time bands.

TIME CURRENT CURVES

Figure 4 is a set of curves for the LimiTrip devices. The long-time element has a characteristic represented by:

$$t_D = K \frac{1}{I^n}$$

where t_D = time delay, I = current expressed in multiples of the long-time pick-up, n is a constant dependent on the circuit design (slightly over 2 for LimiTrip), and K is a constant depending on the delay band selected. In other words, the delay for a given band setting varies approximately inversely as the square of the current. When plotted on log-paper this relationship is a straight line as shown by the sloping bands on Figure 5. Four discrete long-time bands are available, any one of which may be selected by the band control switch. Each band has a delay exactly twice the delay of the next lower band.

The short-time element has a definite delay which is independent of current as shown by the fact that the short-time bands are horizontal on Figure 5. There are three calibrated short-time delay bands — 1, 2 and 3 which have nominal delays of 0.11, 0.22, and 0.44 seconds, respectively.

DESCRIPTION

The width of the time bands on Figure 5 is due principally to differences between devices caused by normal commercial tolerance of components in the circuits. Repeated tests on any one unit will fall in a much narrower band.

The band width also includes breaker interrupting time. The upper limit represents the total clearing time including breaker opening and arcing time, whereas the lower limit is the "resettable time" — the maximum time that the overload can persist without tripping the circuit breaker. This representation, which is necessary to demonstrate coordination between breakers set on contiguous time bands, widens the SHORT TIME bands significantly.

PERFORMANCE IN SERVICE

Ambient conditions and length of service will have little effect on the performance of static overcurrent trip devices. The circuits are stable and will show excellent repeatability over long periods of time. Service involving fre-

quent operations will not cause the characteristics to change or drift, since there are no moving mechanical parts to wear or bearings to lubricate.

LimiTrip devices are tolerant of dusty conditions and will function properly in many areas that would affect the performance of electro-mechanical trip devices.

The temperature at the LimiTrip device does have some effect on the characteristics due to changes in response of some of the components. However, the changes are small and will not be a factor in most applications. Over the range of -30 C to 55 C (-22 F to 131 F), the variation from performance at room temperature is very small, amounting to less than 5% of LONG TIME, INSTANTANEOUS and SHORT TIME PICK-UP values, and 10% in timing of all timebands. Operation is not recommended beyond this range. If necessary, control of the temperature should be provided by heaters or ventilation.

The Connection Diagram in Figure 4 shows in schematic form the pre-wired connections from the breaker mounted tripping transformers to the static trip device.

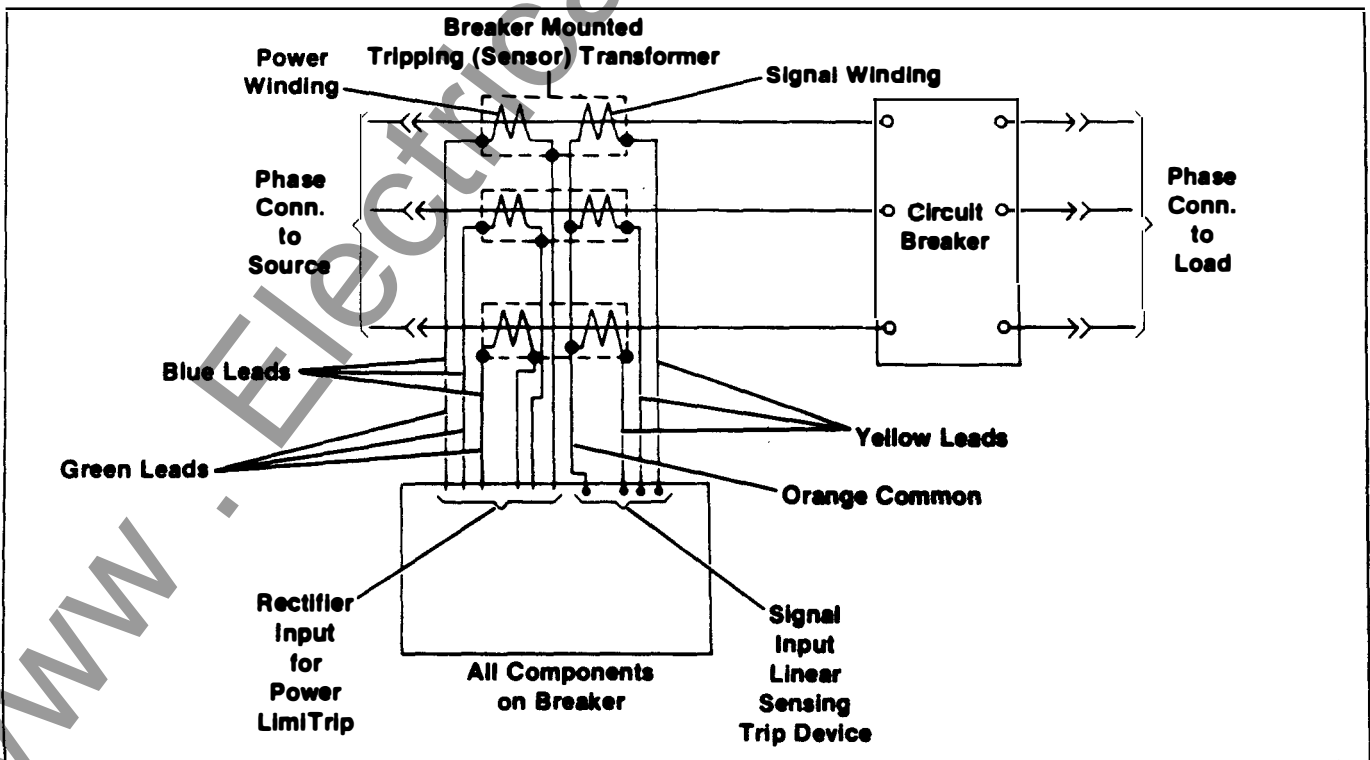

Figure 4. Breaker Wiring for Types LTI, LTS and LTSI

DESCRIPTION

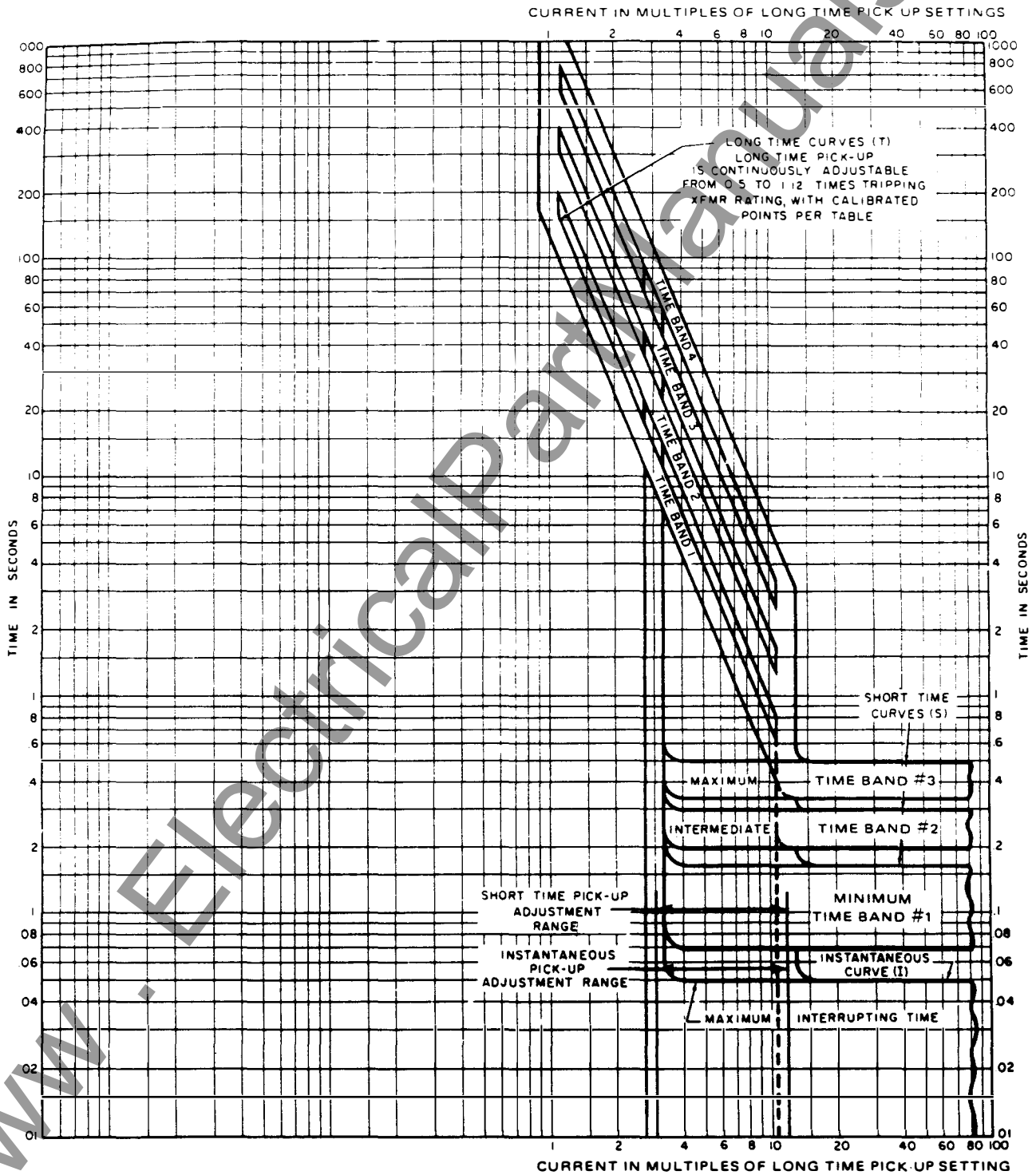

Figure 5. Limit Trip Time/Current Curves

SETTINGS

LIMITRIP SETTINGS

LimriP SETTINGS

LONG TIME

Pick-Up Setting	Switch Number					Time Band	Switch Number		
	1	2	3	4	5		1	2	3
	Switch Position						Switch Position		
A	C	C	C	C	C	#1 (Low)	C	C	C
B	O	C	C	C	C	#2	O	C	C
C	O	O	C	C	C	#3	O	O	C
D	O	O	O	C	C	#4 (High)	O	O	O
E	O	O	O	O	C				
F	O	O	O	O	O				

SHORT TIME

Pick-Up Setting	Switch Number			Time Band	Switch Number	
	1	2	3		1	2
	Switch Position				Switch Position	
3X	O	O	O	#1 (Min.)	C	C
6X	C	O	O	#2 (Int.)	O	C
8X	C	C	O	#3 (Max.)	C	O
12X	C	C	C			

INSTANTANEOUS

Pick-Up Setting	Switch Number		
	1	2	3
	Switch Position		
3X	O	O	O
6X	C	O	O
8X	C	C	O
12X	C	C	C

LEGEND
O = SWITCH OPEN
C = SWITCH CLOSED
X = LONG TIME PICKUP SETTING

www.ElectricalManuals.com

SETTINGS

LimiTrip devices have a number of switches that can be arranged to select specific load current conditions that will cause the breaker to open. Selection of settings is usually made when the breaker is placed in service to match anticipated load conditions and coordination requirements. Future changes are unnecessary unless load conditions change or primary circuit changes are made.

Figure 6 is an illustration of the type LTSI device which contains all LimiTrip control options. The following paragraphs discuss the calibration and use of these controls.

LONG TIME ELEMENT has 6 calibrated pick-up settings "A" through "F" and 4 calibrated time bands "1" through "4" as shown in Figure 7. The long time element operates on the lowest setting so all switches below the desired pick-up or band setting must be open. For example, if we desire pick-up "F" and band "4" all 5 pick-up switches and all 3 band switches must be open; if we desire pick-up "C" and band "3", close pick-up switch number 3 and make certain switches 1 & 2 are open (having switches 4 & 5 closed will have no effect since long time element will operate on the lowest setting — that is the lowest closed switch setting) then close band switch number 3 and make certain band switches 1 & 2 are open.

INSTANTANEOUS ELEMENT has 4 calibrated settings which are multiples of the long time pick-up. The instantaneous element operates on the highest setting so all switches above the desired pick-up must be open. For example, if we desire instantaneous pick-up of 3 times LT pick-up, all 3 instantaneous switches must be open; if we desire 8 times LT pick-up, switches 1 and 2 or 2 only must be closed by moving switch up — switch number 3 must be open.

SHORT TIME ELEMENT has 4 calibrated pick-up settings which are multiples of LT pick-up and 3 band settings. The short time element operates on the highest setting so all switches above the desired pick-up or band setting must be open. This is similar to the instantaneous element.

Figure 7 is a table of settings in amperes for all the standard tripping transformer ratings.

The tripping (sensor) transformer rated secondary current is one ampere. Because setting E, Figure 7 table corresponds to rated tripping (sensor) transformer current, one ampere input to the static trip will cause it to pick up and start timing if LONG-TIME pick-up setting is on "E".

Example: Suppose it is desired that the breaker shall trip whenever sustained current exceeds 600 amperes, and suppose that the tripping (sensor) transformer rating is 800 amperes. The LONG-TIME pick-up setting should be "C", Figure 7 table. At 600 amperes, current input to the static trip will be $600 \div 800 = 0.75$ ampere.

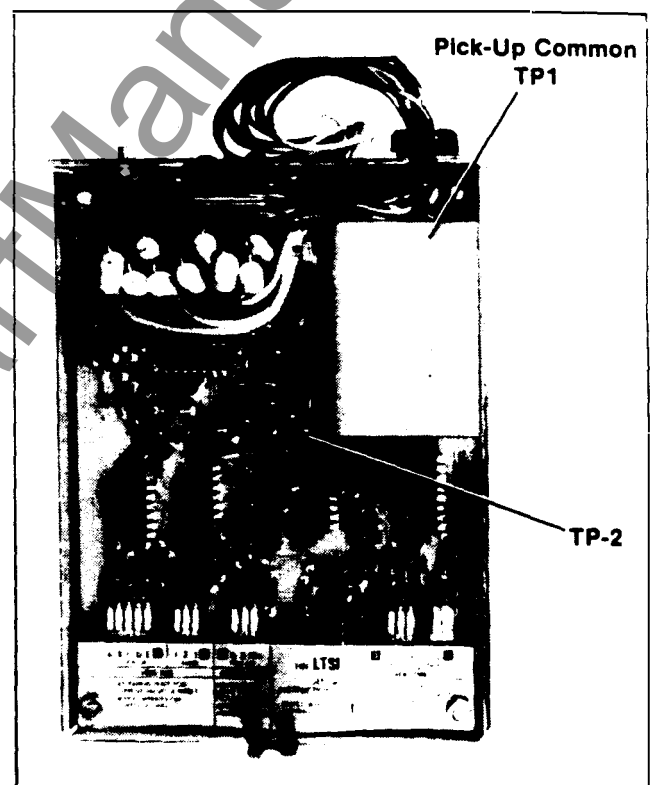

Figure 6. Calibrated Settings on LTSI Device With Cover Removed

INSTANTANEOUS PICK-UP has four calibrated points, 3X, 6X, 8X and 12X, calibrated in multiples of the LONG TIME pick-up setting.

Example: Referring to the previous example, if LONG TIME pick-up is on "C" and INSTANTANEOUS pick-up is on 6X, the breaker will trip instantaneously at 3600 amperes (6×600) or more.

SHORT TIME PICK-UP is calibrated just like instantaneous.

SETTINGS

TIME BANDS

There are 4 LONG TIME BANDS numbered 1 through 4 and three SHORT TIME BANDS marked 1, 2, and 3.

All the LONG TIME & SHORT TIME BANDS are shown on the TIME CURRENT CHARACTERISTICS curve, Figure 5. The curve sheet is self-explanatory.

GENERAL NOTES

1. The "Tripping XFMR Rating" values represent the primary value of the tripping (sensor) transformer ratio in amperes. The secondary value is one ampere.
2. The pick-up settings of the long time element are switch selectable at calibrated points "A" thru "F" as shown in the rating table.
3. The pick-up settings of the instantaneous and short time delay elements are switch selectable at 3, 6, 8 and 12 multiples of the long time pick-up setting.
4. The long time element has 4 bands that are field selectable. The time delay at 6 multiples of pick-up is as follows:

Band 1 — 2.25 seconds	Band 3 — 9 seconds
Band 2 — 4.5 seconds	Band 4 — 18 seconds
5. The short time element has 3 time delay bands which are calibrated at (minimum, intermediate and maximum).
6. The maximum interrupting time is the maximum length of time that fault current flows, including arcing time.
7. Instantaneous maximum interrupting time may be greater when breakers are closed in on a fault depending on actual fault conditions. The maximum potential increase for a 3-phase fault is 0.01 seconds and for a single-phase ground fault is 0.02 seconds.

Tripping XFMR Rating (Primary)	Long Time Element Calibrated Pick-up Settings Primary Amperes					
	A	B	C	D	E	F
600	300	375	450	525	600	675
800	400	500	600	700	800	900
1600	800	1000	1200	1400	1600	1800
3200	1600	2000	2400	2800	3200	3600
4000	2000	2500	3000	3500	4000	4500

Figure 7. LimiTrip Rating Table — Amperes

GENERAL

LimiTrip can be field tested either with primary current through the breaker or with secondary current applied directly to the LimiTrip. The ease of testing with secondary current is one of the advantages of static trip devices. With comparatively inexpensive and readily available equipment, described in the following, it is possible to demonstrate that the tripping system will open the breaker, and to verify that the device conforms to the published time-current curves. However, field testing cannot be expected to be as accurate as factory calibration. Therefore, slight discrepancies between field tests and factory calibration marks can be regarded as normal. If large deviations or improper operation should occur, it is recommended that the nearest Siemens-Allis office be contacted for advice.

SECONDARY CURRENT TESTING

A portable test set is available for secondary testing that is designed to plug into a standard 115 volt outlet, shown in Figure 8. With this test set, LimiTrip can be tested by itself without a circuit breaker, or on a circuit breaker with the breaker away from the cubicle. Earlier generation test sets require an additional transformer to supply power.

CAUTION The LimiTrip input is capacitively coupled to the circuit breaker frame, through a surge capacitor. Therefore to insure against electrical shocks be sure to ground the frame when testing with the circuit breaker out of the cubicle.

Be careful to make connections correctly as shown in Figure 9.

When the LimiTrip device is removed from the breaker for tests, the sensor and actuator wires must be connected to the test set. Making these connections requires the use of clip (alligator style) leads. **CAUTION:** Use care to avoid shorting the clip leads and wire terminals as momentary contact can seriously damage the LimiTrip.

Detailed test instructions are given in the portable test set instruction book. Instruction books for test sets purchased prior to 1978 were written for older style static trip

devices, not for LimiTrip. However, with the information contained in this book, the necessary changes in test procedure when testing LimiTrip units are easily understood. One difference that should be noted is that LimiTrip has two inputs per phase. The LONG TIME pick-up current values for secondary testing are given in Table I below.

The signal current leads are one yellow lead for each phase signal and one common orange lead. The current for test is supplied to these leads.

The power for the device is supplied through the green and blue leads. For testing, these leads must be energized in pairs by an isolated 24 volt, 0.2 amp transformer. To test

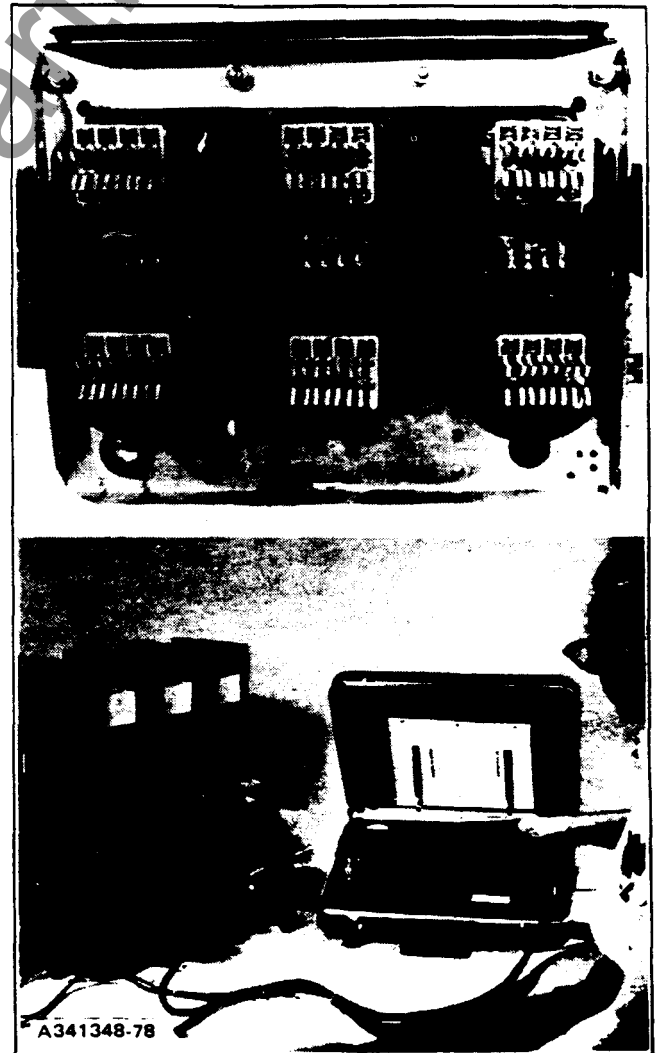

Figure 8. Testing With Portable Test Set

the power supply circuits, each of the green-blue pairs should be energized and the resultant voltage in the device observed. On breakers rated over 2000 amperes the power winding of the transformer must be disconnected from the trip device for testing. Be certain to reconnect the wires after testing.

The power supply voltage can be measured from the negative lead of capacitor C1 to the red output lead of the trip device.

TABLE 1

Long Time Pick-Up Setting	A	B	C	D	E	F
Pick-Up Current, Amps	.50	.625	.75	.875	1.00	1.125

TESTING WITHOUT A PORTABLE TEST SET

The portable test set has its own automatic timer which permits accurate testing of all time delays. If the test set is not available, however, it is possible to perform function tests and some timing tests if the following equipment is available.

1. One variable transformer (Variac) 115 or 120 volt, 60 Hertz, 2.5 amperes minimum.
2. One air core reactor, 30 to 50 milli-Henries, 2 amperes minimum. Maximum dc resistance — 20 Ohms.
3. One ac ammeter, 0-1 or 0-2 amperes — necessary for accurate checking of LONG TIME PICK-UPS.
4. One ac ammeter, 0-5 amperes, for LONG TIME delay tests and INSTANTANEOUS and SHORT TIME pick-ups.

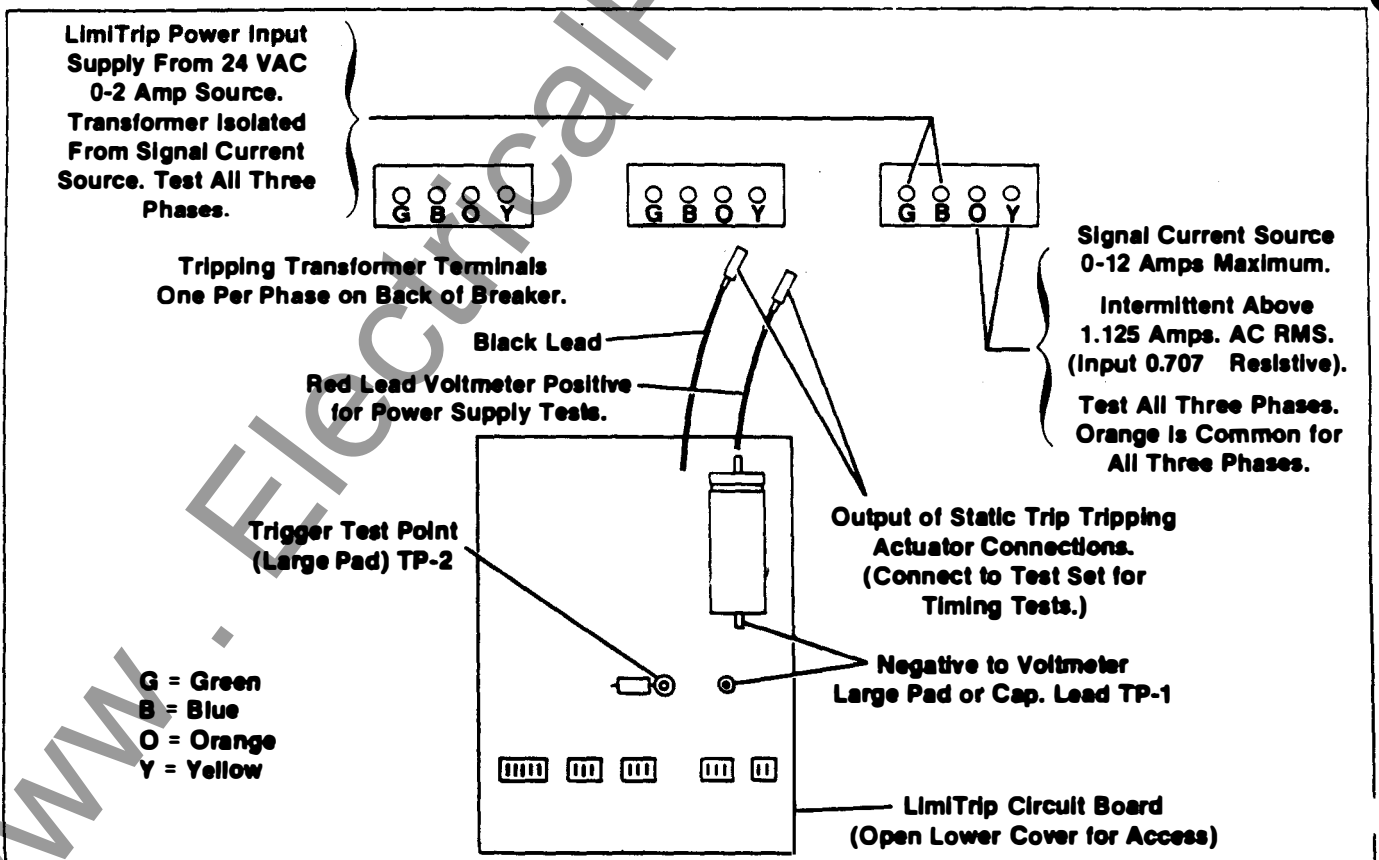

Figure 9. LimiTrip Test Connections

5. One dc voltmeter, 0-25 or 0-50 volts, for trigger indication.
6. One stop watch, desirable but not essential, for timing tests.
7. One single pole — single throw, snap action switch rated 120 volts, 5 amperes ac or more.
8. One 120V/24V approximately 1/2 amp transformer.

TEST CONNECTIONS

See Figure 10 for test connections. Connect the input to yellow and orange leads. Test all three yellow leads.

LONG TIME PICK-UP TEST

For this test a circuit breaker is not needed. If the LimiTrip is mounted on a breaker, it is not necessary to close the breaker.

Use the 0-1 to 0-2 ampere ammeter. Connect the voltmeter to terminals TP1 and TP2 with TP1 negative. Refer to "Secondary Current Testing" for tips and cautions on making connections.

Set LONG TIME PICK-UP on "A". Raise the current gradually until the voltmeter needle jumps suddenly to 7 volts or more. The current at which this occurs should be 0.5 am-

peres \pm 10%. Decreasing the current slightly should cause the voltmeter reading to drop to a low value. Repeat for the other LONG TIME PICK-UP settings and compare with Table I.

The sudden appearance of this "trigger" voltage indicates that the timed delay has started. If the current drops slightly, causing the trigger voltage to disappear, the timing circuit resets instantly and timing will restart upon the next appearance of triggering.

SHORT TIME PICK-UP TEST

Use the 0-5 ampere ammeter and connect the voltmeter to the red and black terminals with black negative. Set LONG TIME PICK-UP on A and SHORT TIME PICK-UP on 3X. INSTANTANEOUS (if so equipped) on 12X. Raise the current until the voltmeter suddenly jumps up as before. This should occur at 1.5 amperes (3 x 0.5). Repeat for SHORT TIME PICK-UP settings of 6X and 8X which should give readings of 3.0 and 4.0 amperes respectively, (6 x 0.5 and 8 x 0.5). You may not be able to get the 6.0 amperes for the 12X setting even with the variable transformer at maximum output.

CAUTION

Do not allow current above 2 amperes to continue more than a minute or so at a time so as not to overheat the LimiTrip, the variable transformer and the reactor.

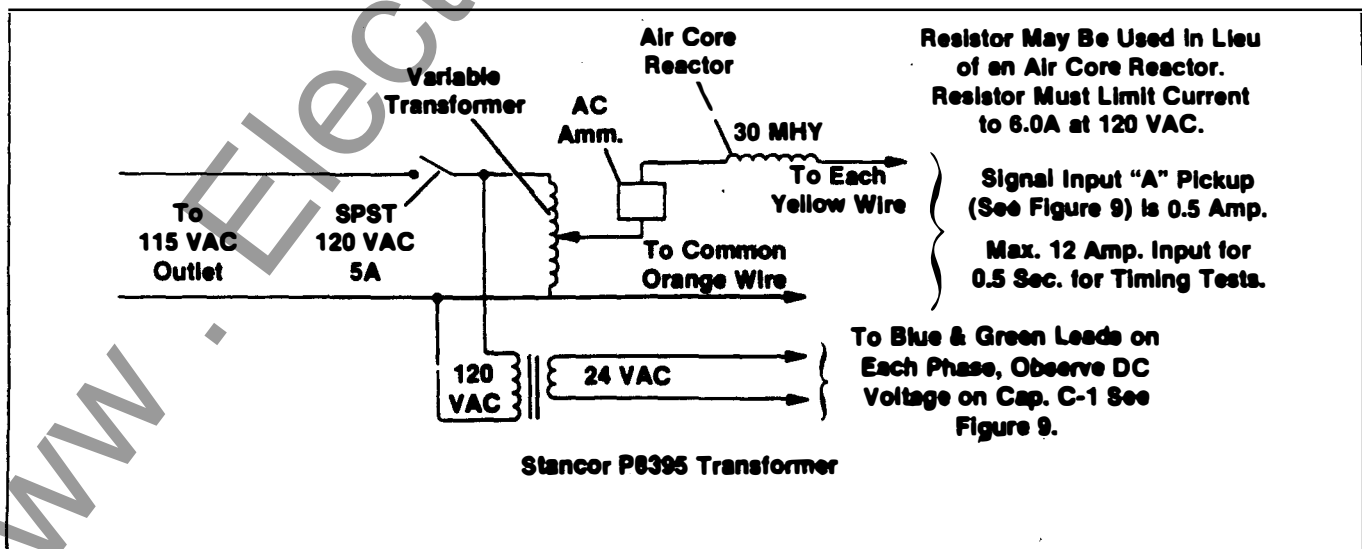

Figure 10. Secondary Testing Without Test Set

INSTANTANEOUS TRIP TEST

There is no trigger output for INSTANTANEOUS, but tripping of the breaker will indicate operation when testing with the LimiTrip unit on a breaker. When testing without a circuit breaker, connect the voltmeter from red wire to black wire with black negative to monitor the trip device output.

Use the 0-5 ampere ammeter. Set LONG TIME PICK-UP on "A" and INSTANTANEOUS on 3X and short time on 12X if so equipped. Gradually increase current until the voltmeter indication jumps up to 15 volts or more indicating that the instantaneous circuit has caused a tripping output. This should occur at about 1.5 amperes (3×0.5). Repeat for the 6X and 8X INSTANTANEOUS PICK-UP settings which should cause operation at 3.0 and 4.0 amperes respectively.

NOTE Because of the load imposed by the actuator coil, the voltmeter indication will be much less, perhaps as low as 5 volts, if the static trip output, is connected to a circuit breaker.

LONG TIME DELAY TEST

For current less than 6 times pick-up setting and time bands 2 and higher, the delay is long enough to be checked fairly well with a stop watch or even an ordinary watch having a sweep second hand.

Use the 0-5 ampere ammeter.

1. Close the switch and adjust current to the desired value.
2. Open the switch and close the circuit breaker.
3. Without changing the variable transformer setting, close the switch and measure the time interval from switch closing to breaker tripping.

Example: Set LONG TIME PICK-UP on "A", LONG TIME BAND on 4, input current at 3.0 amperes (6×0.5). Set SHORT TIME and/or INSTANTANEOUS pick-up on 12X, above the input current value. The timed interval should be between 14 and 22 seconds. See the curves on Figure 4.

If the LimiTrip is not mounted on a circuit breaker, connect the voltmeter across black and red terminals of the LimiTrip and time the interval from switch closing to voltmeter indication.

NOTE While timing out at values of input current not much above pick-up, normal fluctuations in supply voltage may cause the device to de-trigger (see the last paragraph under "Long time Pick-Up Test") and prevent the device from timing out properly. To avoid this it is desirable to monitor LONG TIME trigger output with a voltmeter throughout the test.

SHORT TIME DELAY TEST

The SHORT TIME delays are too short (0.5 second maximum) to be checked without a high speed automatic timer, but it is possible to perform a test to verify that the short time circuit will trip the breaker. To do this follow the instructions for testing INSTANTANEOUS as described previously, but set the INSTANTANEOUS, if there is one, above the input current level and the SHORT TIME PICK-UP below the input current level.

Example: Set LONG TIME PICK-UP on "A", SHORT TIME PICK-UP at 3X (1.5A.), and INSTANTANEOUS (if applicable) on 12X (6.0A.). Close the breaker and apply 2 to 5 amperes by closing the switch. The breaker should trip in about 1/2 second or less depending on the SHORT TIME BAND setting. If the LimiTrip is not on a breaker, the voltmeter may be used as before to obtain an indication of the static trip output at red and black terminals.

TRIPPING ACTUATOR TEST

If the LimiTrip fails to trip the breaker, the question arises as to whether the trouble is in the LimiTrip or the actuator. Substitution of another LimiTrip may supply a quick answer.

If another LimiTrip is not available, there is a simple test of the actuator. However, a dc power supply with output adjustable from 3 to 12 volts minimum at 0.3 ampere minimum is required. Such a power supply is contained in portable test sets built after late 1972.

Disconnect the LimiTrip from the actuator. With an ohmmeter or resistance bridge measure the resistance of the actuator coil from its red to its black lead. This should be 30 to 40 ohms.

Disconnect the ohmmeter and connect the output of the test set power supply to red and black actuator leads with black negative. Close the breaker and slowly increase the dc voltage from minimum. Note and record the voltage at which the breaker trips.

CAUTION Although the tripping actuator can be easily disassembled, doing so may partially demagnetize it, and remagnetizing requires special equipment.

Failure of the breaker to trip at any actuator voltage even up to 12 volts may be due to the plunger of the actuator not being reset fully so that the permanent magnet does not hold it in the reset position. This can be checked visually. See the circuit breaker instruction book.

SENSOR TRANSFORMER TESTS

The tests described in the preceding verify performance of the LimiTrip device and the tripping actuator.

The third link in the LimiTrip protection system is the breaker-mounted tripping current transformers. When secondary current testing is done with the LimiTrip on the breaker, the sensor transformers are subjected to approximately their normal excitation so that a transformer with shorted turns would show up in the form of pick-up values above tolerance. However, there would be no way of knowing whether the problem was in the LimiTrip or the transformers. Moreover, an open circuit in the transformer winding or wiring would not show up at all. Therefore, it is desirable to test the tripping transformers as described in the following:

CONNECTIONS

If the LimiTrip device is on the breaker, disconnect it from the transformers. The sensor transformers can now be tested by making connections to its terminals.

CONTINUITY CHECK

An ohmmeter is most suitable for checking continuity of the transformer secondary windings and wiring.

Disconnect the yellow wire from the "Y" terminal of each phase transformer. Continuity through each signal winding can be verified, terminal "O" (orange wire) to the "Y" terminal.

The wiring and LimiTrip signal input can be checked from each yellow wire to the orange wire "O" terminal. The input resistance of the trip device should be 0.707 Ohms. The resistance of the transformer winding will vary with the transformer ratio from approximately 0.2 Ohms for 80/1 to approximately 15.0 Ohms for 4000/1.

For power circuit transformer continuity check, remove the green or blue wire from each transformer. The LimiTrip input should be approximately 1000 Ohms; the transformer winding resistance should be approximately 5 Ohms for transformers under 2000 Amp and approximately 3 Ohms for 2000A and up.

After checking, be certain to reconnect all wires to their proper terminals and securely tighten all screws.

EXCITATION TESTS

The purpose of the excitation test is to reveal shorted turns in the sensor transformer winding. Sixty Hertz ac voltage is applied to the secondary winding and the exciting current is monitored. Short circuited turns will be revealed by excessive exciting current and perhaps by overheating of the winding. If a portable test set is available, it may be used to furnish the applied voltage, and the ammeter on the set may be used to monitor exciting current. It is desirable, but not essential, to also have an ac voltmeter of 0-150 volts scale to measure the applied voltage. Many multi-testers have such a voltmeter range as well as an ohmmeter range for continuity tests. In the absence of a voltmeter, the dial reading of the variable transformer may be used as an approximate voltage indicator. See Table 2. If a portable test set is not available, the equipment listed under "Testing Without a Portable Test Set" can be used.

Again, each phase must be tested in turn. Connect the ac

supply to terminals "Y" and "O" for A phase, "Y" and "O" for B phase, and "Y" and "O" for C phase.

Table 2 gives applied voltage and test limits of exciting current for all the standard sensor transformer ratings. The figure .02 ampere in the table is used because that is about the lowest readable current on the test set ammeter, and transformers that meet this limit will give satisfactory performance. Normal exciting current for the 800:1 and up ratings may be well below this value. Therefore, it is essential, for ratings of 1000:1 and higher, to perform the continuity check. On the lower ratings the continuity check can be omitted since the deflection of the ammeter verifies continuity.

TABLE 2

Sensor transformer exciting current test signal winding "Y" and "O" terminals only. (Check "B" and "G" terminals for continuity only.)

Sensor Transformer Ratio	Applied Volts (RMS)	Maximum Exciting Current Amps (RMS)
80:1	4.6	0.25
200:1	7.0	0.15
400:1	17.0	0.05
600:1	32.0	0.05
800:1	34.0	0.03
1000 and up	34.0	0.02

level. When supplied from a low voltage source that cannot provide a pure sine wave of current, the waveshape supplied to the LimiTrip will be altered. This results in either insufficient power to properly operate the LimiTrip device or it may affect the indication of the source ammeter, depending on the ammeter design, leading to the erroneous assumption that the LimiTrip calibration is incorrect.

One other major difficulty with primary current testing is related to the duty cycle limitation of the circuit breaker and sensor transformers. A properly operating tripping system will be self-protecting from thermal damage up to the circuit breaker short time and interruption rating provided that the duty cycle applicable for each rating is not exceeded. The standard duty cycle for the short time rating as demonstrated per ANSI C37.50 is 0.5 seconds ON, 15 seconds OFF followed by a second ON time of 0.5 seconds. The ON intervals generally are too short to read the ammeter for the current source. For the instantaneous interruption rating, the ON times are reduced to 50 milliseconds. Because of this, calibration of the trip device high range settings cannot be accurately done with primary current. The calibration can be verified safely at the lower settings and operation only verified at the higher set points.

If the duty cycle limits are exceeded during testing, the circuit breaker or sensing transformers may be damaged. Between tests, the unit must remain OFF long enough to allow the sensor transformers to cool. In addition, if there was a fault in the tripping system and the breaker could not trip within its rated time limits, the system would not be self-protecting.

Therefore to properly protect the tripping system from potential damage and still assure proper operation, the following procedure is recommended.

1. Apply to one phase of the circuit breaker an input current of one-half sensor transformer rating and measure the trip device power supply voltage. This voltage is across the filter capacitor from its negative terminal to the red actuator lead. If this voltage exceeds 18 volts, the distortion of the input current can be disregarded except for its effect on the ammeter reading. Test all three poles of the circuit breaker in the same manner. This establishes that the device power circuits are operating.
2. Set the long time pick-up control to the "A" position, slowly increase the current from zero while watching the long time trigger output. Pick-up should occur at

PRIMARY CURRENT TESTING

Testing with primary current applied to the circuit breaker requires a low voltage, high current supply that can deliver currents up to 4 or 6 times the sensor transformer rated current.

Primary current testing can provide the ultimate assurance that the entire protective system is functioning properly since the entire system is tested at one time. However, primary current testing may present additional problems. One major difficulty arises from the non-linear impedance of the LimiTrip power supply circuit. The transformers that supply power to the static trip circuit are designed to saturate to limit the input to an acceptable

one-half the sensor transformer rating plus or minus 10% not including ammeter error. Pick-up is indicated by a sudden increase in the trigger voltage. Repeat for all three poles of the circuit breaker. When the trigger is present, the long time circuit timing oscillator is released and the device will time out on long time. Repeat calibration check on the other long time pick-up calibration points if desired.

3. Set long time pick-up on "A", long time band control on Band one, instantaneous and short time pick-up on 12X, and the input current equal to the sensor transformer rating. Remove and reapply power. Allow the device to time out and trip the breaker. The time to trip should meet the published curves for the device being tested. Repeat for all long time bands. Note that if the input current waveshape is distorted, the time delay may be less than expected. Some newer primary current test sets have peak responding ammeter circuits that will properly indicate current magnitude when waveshape distortion is present.
4. Set instantaneous at 3X, short time at 12X, long time band on its maximum. The breaker should trip instantaneously at 1.5 times the sensor rated current. Repeat for all three poles of the breaker.
5. Set short time pick-up at 3X, instantaneous at 12X, long time band on its maximum, and short time band on minimum. Slowly increase current. The breaker should trip on short time at 1.5 times the sensor rated current. The short time "time delay" can allow the current to increase after tripping has been initiated, so the rate at which the current is increased must be limited to prevent "over shoot".
6. With the same settings as in Step 5, adjust the supply current to 3 times the sensor transformer rating. Apply the current and observe the breaker tripping time.

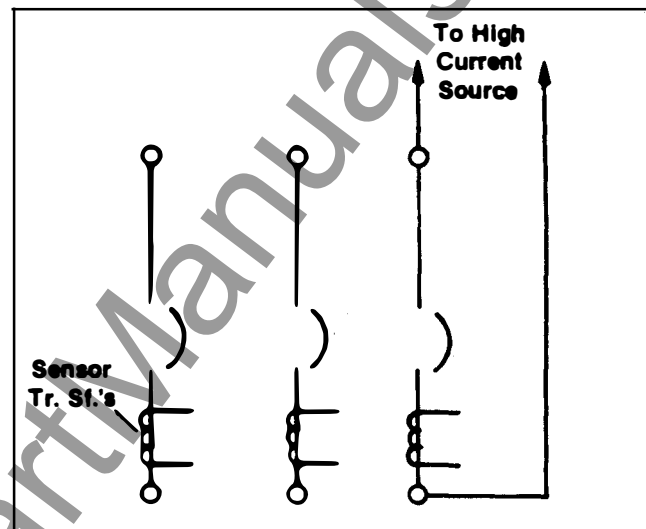

Figure 11. Primary Current Testing

Test all three short time bands and verify that the short time delay matches the published curves.

7. Set the instantaneous and short time pick-up switches to their maximum and set the long time band on minimum (if adjustable). Adjust the supply current to twice the sensing transformer rating. Apply the current and observe the breaker tripping time. Test at the same current for all time bands and verify that the long time delay matches the published curves. Other values of current can be tested if overheating is prevented.
8. To demonstrate operation at normal control setting, reset all controls to their desired condition, set current to a value high enough to definitely cause tripping, apply current, and verify that tripping occurs.

REPAIR

Because of the complexity of some of the semi-conductor components, for example, the integrated circuits, we do not recommend field repair of LimiTrip units. Moreover, component failure usually does not show up as visual damage and locating the defective component or com-

ponents requires specialized techniques. Therefore, if the tests described in the preceding section indicate that a LimiTrip device is defective, contact your Siemens-Allis representative for instructions on returning the unit to the factory for repair.

76

MAINTENANCE

Each trip device is adjusted, calibrated, and tested before shipment. It is ready for use after the appropriate settings have been selected.

Because there are no moving parts, no readjusting, lubricating, etc. is required. The only maintenance that is required is periodic verification that the device is functioning. This may be supplemented as desired by checking the calibration, inspecting for loose or broken external wiring, restoring lost calibration, and where unusually dusty conditions exist, periodic cleaning.

CLEANING

In extremely dusty atmospheres, enough dust may in time accumulate to prevent adequate cooling of components. LimiTrip units are easily disassembled for cleaning.

With the cover open, Figure 12, all components are exposed for cleaning. Cleaning can be done with a very soft brush or with compressed air. In the latter case, be sure the air is clean and dry and that the jet is not too strong.

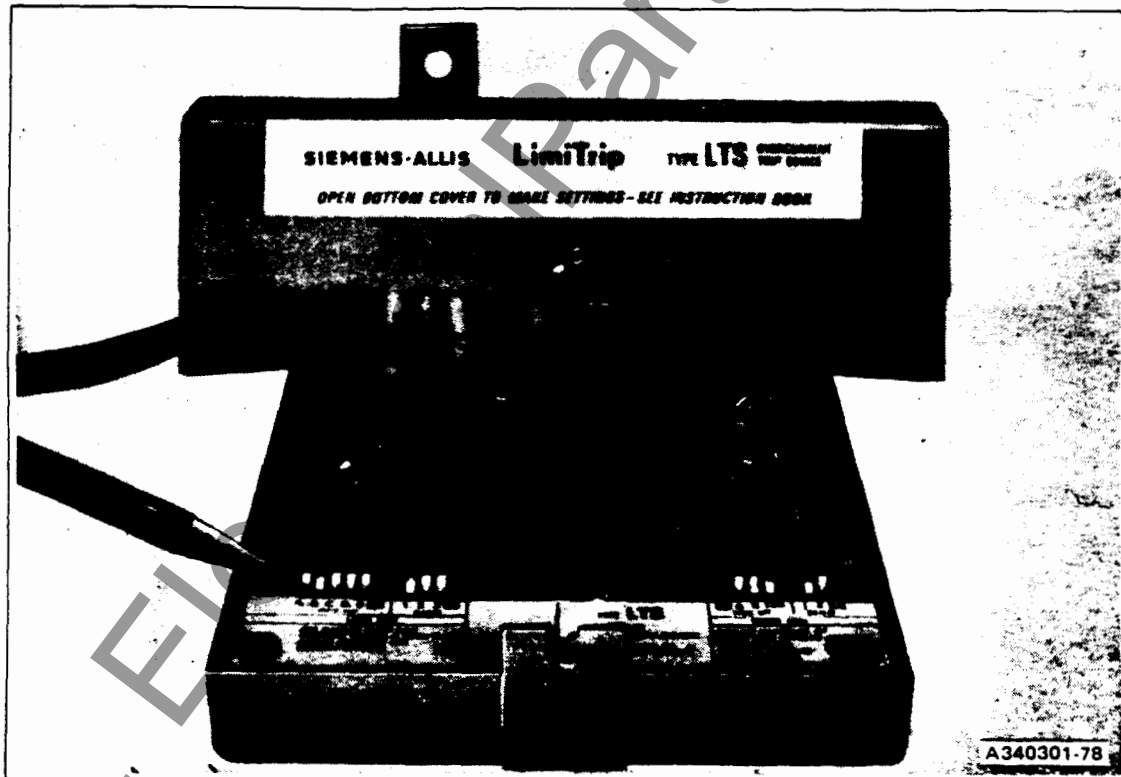

Figure 12. LimiTrip — Cover Open

SIEMENS-ALLIS

Siemens-Allis, Inc.
Switchgear Division
P.O. Box 29503
Raleigh, NC 27626
(919) 365-6660

www.ElectricalPartManuals.com