

## Installation Instructions

For 2500-4000A Power Break with Micro-VersaTrip® and for 2500-3000A Power Break with MagneTrip™ trip units.



# Power Break Accessories

## For Field Installation in 2500-4000A Breakers

### Introduction

These instructions cover the field installation of internally mounted electrical accessories as listed under "Contents." The accessories are listed by Underwriters Laboratories, Inc. as "Circuit Breaker Accessories."

### General

Since installation of all accessories requires the removal of the circuit breaker frame cover, such steps are presented on page 2 and are not repeated. Likewise, other steps, which are required for several accessories, are given only once and reference back to them are made.

### Tools Required

5/16" Wide Blade  
Screwdriver  
Small Hammer  
5/16" Wrench  
9/16" Socket Wrench  
5/16" Allen Hex Wrench  
Torque-Wrench (suggested).

### Test Equipment

Volt meter  
Continuity tester  
Variable transformer  
(see Electrical Data Table on page 7 for power requirements).

### Note:

These accessories are also suitable for field installation in 4000 non-interchangeable trip PowerBreak breakers with MagneTrip trip units; field installation, however, voids the UL Listing. Remove and discard the UL label on the circuit breaker.

### Contents

Cover and Trip Unit Removal	2
Shunt Trip Device	4
Undervoltage Release Device	6
Blown Fuse Trip Device	7
Auxiliary Switch	9

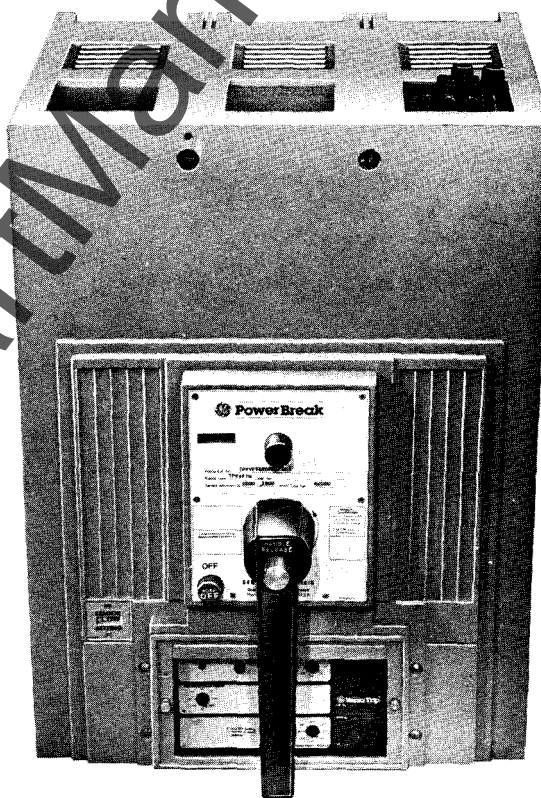

### Circuit Breaker Cover Removal

**Warning:** When installing accessories, the breaker must be completely de-energized and disconnected from the electrical circuit. This is mandatory because breaker must be "ON" during certain stages of installation and testing.

## CIRCUIT BREAKER COVER REMOVAL

**WARNING:** When installing accessories, the breaker must be completely de-energized and disconnected from the electrical circuit. This is mandatory since breaker must be on during certain stages of installation and testing.

**CAUTION:** Do not turn breaker up-side-down. Loose parts may become lost.

### 1. Cover Removal — Manual Breakers

- Press the OFF button on the circuit breaker.
- Remove the escutcheon plate from the breaker cover (4 screws). See Fig. 1.
- Remove the four breaker cover screws and lift off the cover.

Electrically Operated Breakers — See Fig. 2.

### 2. Outer Cover Removal

- Disconnect all external leads from the terminal board. See Fig. 4.
- Remove the breaker outer cover. See Manual Circuit Breakers-Cover Removal.

**NOTE:** When removing the breaker outer cover, be sure that the terminal board support slips out of the notch in the outer cover and remains with the motor-power unit assembly.

**NOTE:** To prevent disturbing factory adjustment do not separate the motor-power unit from the inner cover.

### 3. Inner Cover Removal

Unscrew the inner cover retaining screw, Fig. 3, and remove the inner cover assembly from the breaker base.

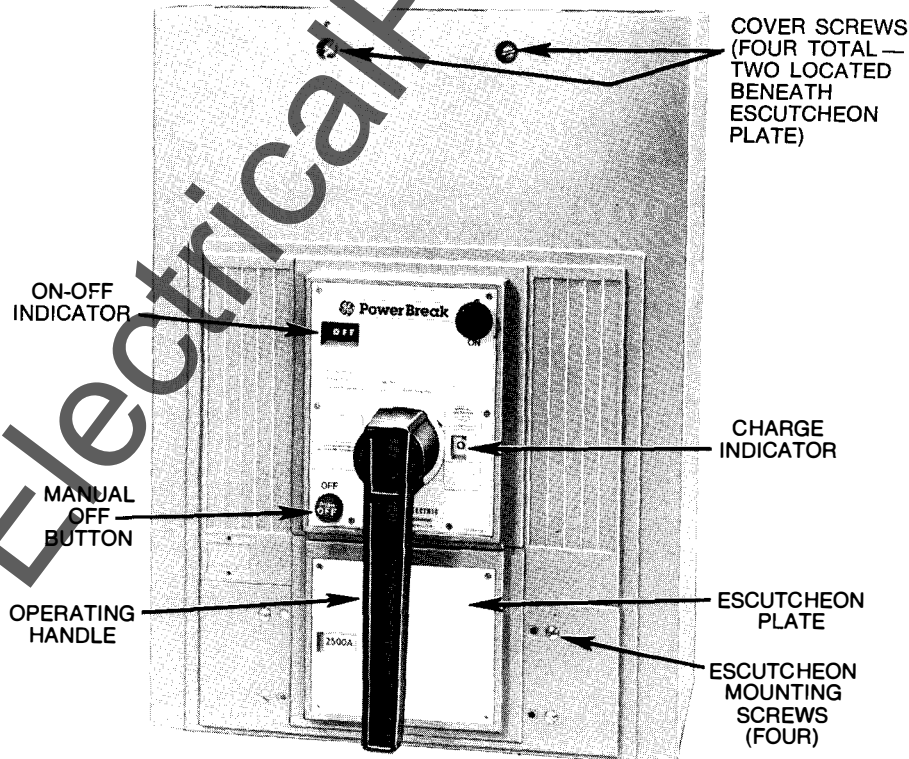

Fig. 1. Manually operated 3000A MagneTrip

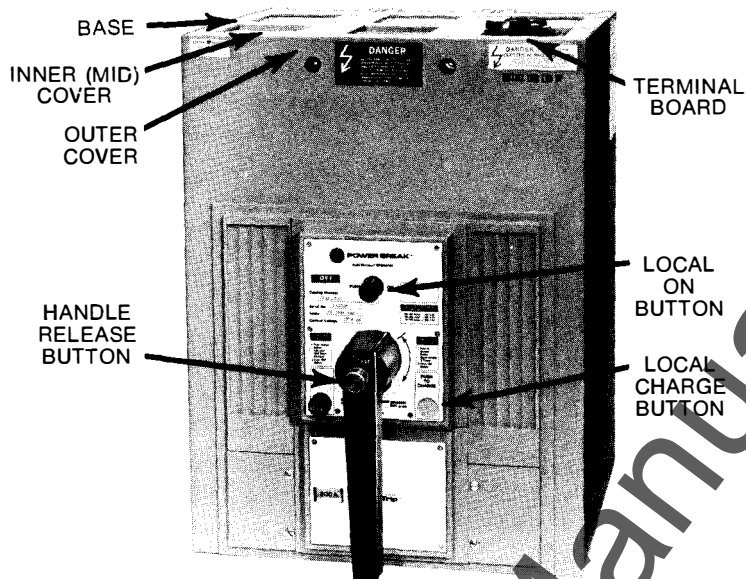

Fig. 2. Electrically operated

4. For easier installation of shunt trip, UVR or Blown Fuse Trip, remove Circuit Breaker Trip Unit.

- a. Micro-Versatrip Trip Unit — press in lock release lever on side of trip unit while pulling up unit.
- b. MagneTrip Trip Unit (Dual-Magnetic — 3000A max.) —

1. Unscrew the hex-head bolts from the line end of the trip unit coils, but leave them in position.

2. Unscrew the socket-head bolts and washers from the load end of the trip unit coils.

3. Unscrew the round-head screws (4) supporting the trip unit.

4. Remove the trip unit.

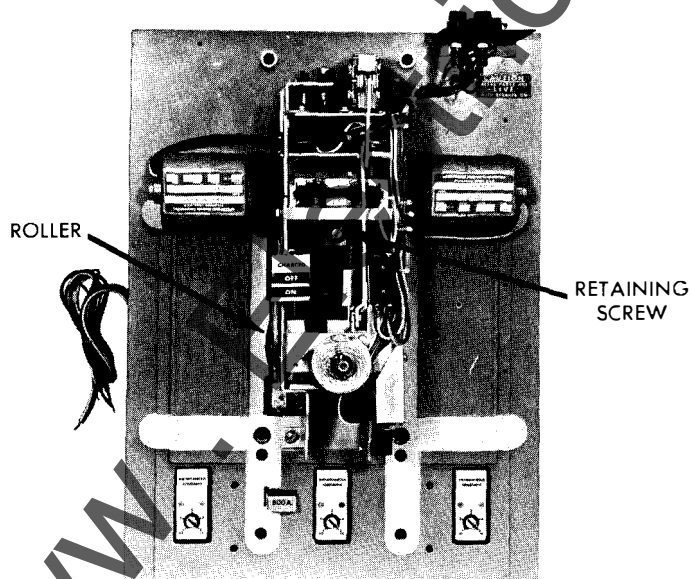

Fig. 3.

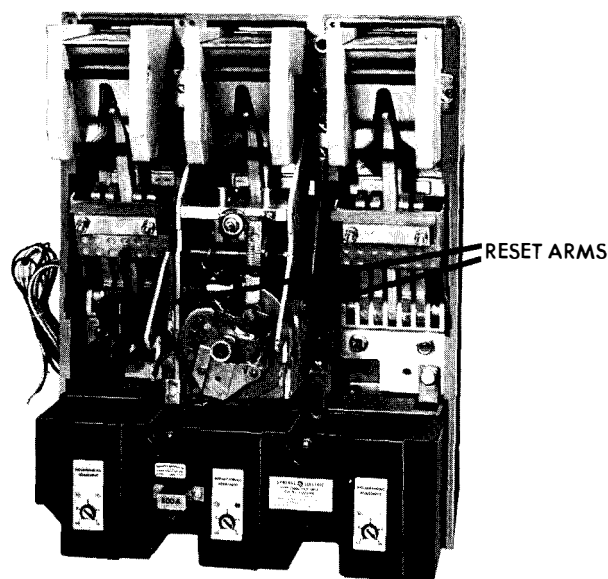

Fig. 3A. Breaker base and mechanism

Once the circuit breaker cover(s) has been removed, installation of the accessory may be completed. Refer to specific accessory installation below.

## SHUNT TRIP DEVICE GENERAL DESCRIPTION

The shunt trip device provides remote control capability to trip the circuit breaker. A cutoff switch is supplied as part of the shunt trip to automatically remove power from its coil when the circuit breaker is tripped.

Shunt trip device catalog numbers with suffix R or RB are for right side mounting; those with suffix L or LB are for left side mounting.

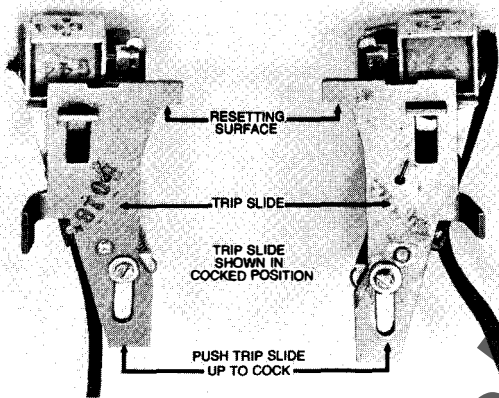

Fig. 4-L Fig. 4-R  
Shunt trip device - left side and right side mounted.

## ELECTRICAL DATA

CAT NO.	VOLTAGE RATING	MAX INRUSH CURRENT AMPS
TSST7	12 Vdc	4.00
TSST8	24 Vdc	2.18
TSST9	48 Vdc	1.09
TSST10	125 Vdc	1.00
TSST11	250 Vdc	0.21
TSST12	120 Vac	2.25
	240 Vac	4.50
TSST13	480 Vac	1.64
	600 Vac	2.05

## INSTALLATION

- Block the breaker crossbar down at least 1" so that the mechanism resetting pin will be below the shunt trip slide resetting surface. See Fig. 6.
- For right side mounted device, Fig. 4-R:
  - Remove the left knockout in right pole of the breaker base, using screwdriver and hammer as shown in Fig. 5.
  - Remove all debris from breaker.
- For left side mounted device, Fig. 4-L:
  - Remove right knockout in left pole of breaker base, using method shown in Fig. 5.
  - Remove all debris from breaker.
  - Insert shunt trip leads into mechanism above the trip slide extension arm so that leads come out of the mechanism below the extension arm. See Fig. 6.
- For either right or left side mountings:
  - Place the shunt trip device inside the breaker mechanism frame, as shown in Fig. 6 or 7.

**NOTE:** The left side mounted device requires some care in maneuvering it through the space between the breaker trip slide and latch assembly.

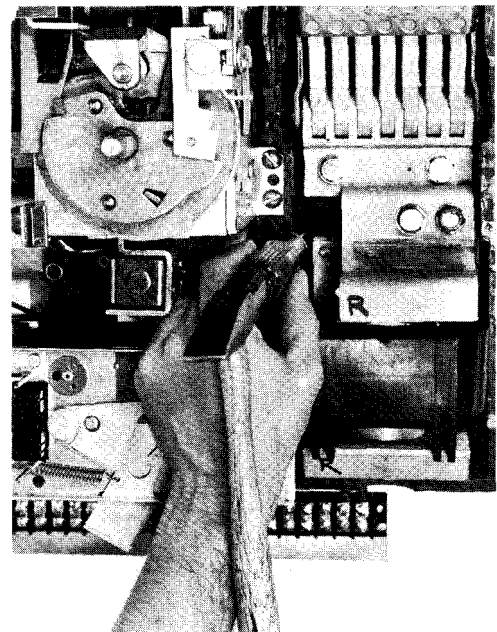

Fig. 5 View showing knockout method

- b. Install mounting screws through slotted holes into tapped holes in shunt trip frame.
- c. Position unit to provide 1/16-inch to 3/32-inch gap, as shown in Fig. 7, and tighten screws to 15-inch pounds torque.
- d. Check to ensure that the resetting-roll pin is installed beneath the trip slide resetting surface.
- e. Check to ensure that the trip slide moves freely. It may be necessary to reposition the solenoid leads slightly to ensure free movement (for left side mounting only).

5. Install the cutoff switch as follows:

- a. Remove the left hex-head mounting bolt.
- b. Discard the plain washer and install the switch assembly, as shown in Fig. 8, using bolt and lock-washer.
- c. Torque the bolt to 30-inch-pounds while holding the auxiliary switch in the proper mounting position.
- d. Insert the wires and flexible sleeving from the shunt trip through the slot in base.
- e. Connect insulated spade terminal from shunt trip to mating connector on cut-off switch.
- f. Pass the other lead through the flexible sleeve on the switch assembly and thread this bundle through the knockout in the breaker base and along the back for attachment as desired.
- g. Install wire ties on wire bundle on the inside and outside of base to provide strain relief. See Fig. 8.

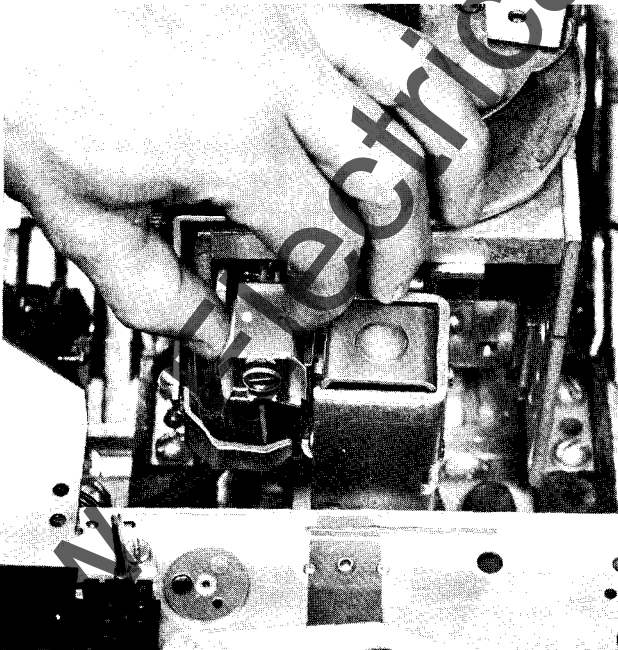

Fig. 6. View, left side mounting

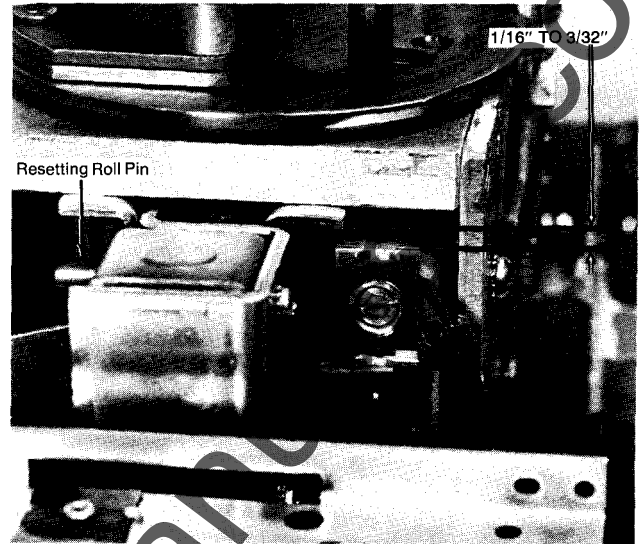

Fig. 7. View of shunt trip and auxiliary switch installation

6. For functional check, replace trip unit first;

a. Manual circuit breakers:

- 1. Replace the breaker cover but do not tighten mounting screws (four).

b. Electrical circuit breakers:

- 1. Install inner cover. Refer to step 3, page two.
- 2. Install outer cover but do not tighten mounting screws (4).

7. Functional check

- a. Turn on circuit breaker by cranking handle a third time, then push ON button.
- b. Apply 55 percent of the rated accessory coil voltage to check the electrical and mechanical operation of the shunt-trip device. The main breaker contacts should open. Verify that voltage has been removed from the shunt trip coil.
- c. Apply descriptive label to front of cover.

8. Reassemble the breaker as outlined on page 6.

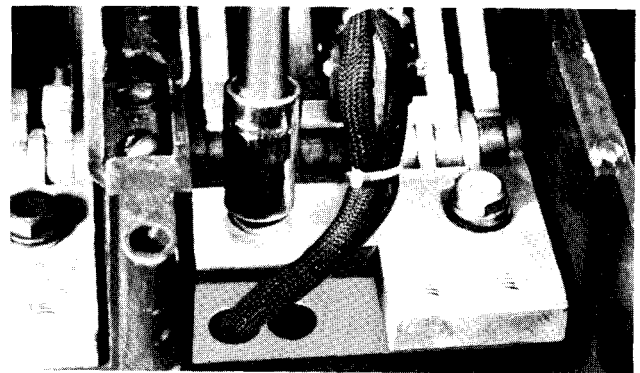

Fig. 8

## COVER REASSEMBLY

### 1. Manual Circuit Breakers

*NOTE: When replacing the circuit breaker outer cover, the phase barriers and the flat area on the handle shaft must be properly aligned.*

- a. Install the breaker cover (4 screws).
- b. Install the escutcheon plate (4 screws).

*NOTE: If the breaker was removed from its supporting structure, use tape to hold the wires in the wiring channel, as shown in Fig. 9, to ensure that no wires are pinched under the breaker mounting pads.*

### 2. Electrically Operated Breakers

#### Inner Cover Installation

- a. Slide the inner cover and motor-power unit assembly onto the breaker base and mechanism. Ensure correct alignment of the handle shafts (cam shaft and extension shaft) and that the reset arms engage the grooves in the rollers shown in Fig. 3A.
- b. Tighten the inner cover retaining screw shown in Fig. 3.
- c. Reinstall the trip unit (solid state programmer or MagneTrip). Refer to removal instructions.

#### Outer Cover Installation

- d. Install the breaker outer cover (4 screws). See Fig. 2. Be sure that the terminal board slides into the slots in the circuit breaker cover. See Fig. 3.
- e. Install the escutcheon plate (4 screws). See Fig. 1.
- f. Reconnect the power leads at the terminal board. See Fig. 2.

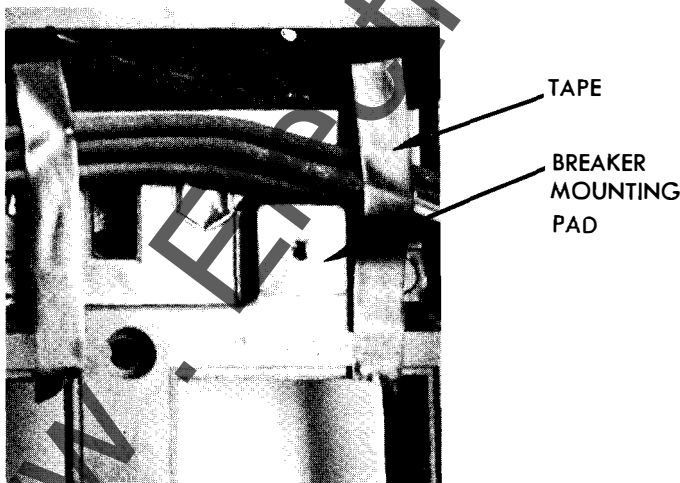

Fig. 9. View, back of breaker

## UNDERVOLTAGE RELEASE DEVICE (UVR)

### GENERAL DESCRIPTION

The undervoltage release device, Fig. 10, is used to open the circuit breaker when the supply voltage drops to 35-60 percent of the rated voltage.

### INSTALLATION

Installation of the undervoltage release device is very similar to the shunt trip (right side).

1. Breaker Cover Removal — follow steps 1-3 on page 2.
2. Refer to steps 1, 2, 4, under "Shunt Trip Installation" to install the UVR in right side of the center pole.

*NOTE: It is very important to be sure the resetting roll pin is beneath the resetting surface of the resetting lever. See Fig. 11 and Fig. 6.*

3. Insert the leads through the knockout and position them, as shown in Fig. 7, with tape to ensure that leads will not be pinched under the breaker mounting pads during installation. Check the leads at the undervoltage release device to be sure they do not interfere with any moving parts.
4. Install wire ties on wire bundle on the inside and outside of base to provide strain relief. See Fig. 8.
5. Functional Checks
  - a. Replace the cover or covers (electrically operated).
  - b. Apply rated voltage to the coil and close the breaker. Reduce the voltage to the coil and verify that the device drops out.
6. Apply descriptive label to circuit breaker cover.

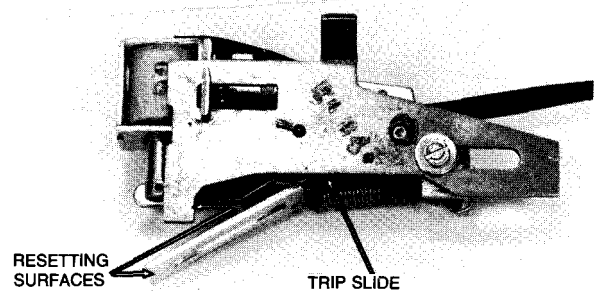

Fig. 10. Undervoltage release device

## ELECTRICAL DATA — UNDervOLTAGE RELEASE

Cat. No.	Rated Voltage (60 HZ ac)		MA Current		Dropping Resistor (Ohmite Type 270)
	dc	ac	dc	ac	
TSUV1	120V	ac	—	25	none
TSUV2†	240V	ac	—	25	5000Ω; 25 watt
TSUV4†	480V	ac	—	25	15,000Ω, 50 watt
TSUV6†	600V	ac	—	25	20,000Ω, 50 watt
TSUV7	12V	dc	211	—	none
TSUV8	24V	dc	104	—	none
TSUV9	48V	dc	54	—	none
TSUV10	125V	dc	24	—	none
TSUV11†	250V	dc	24	—	5000Ω, 25 watt

†Externally mounted dropping resistor supplied with device.

## BLOWN FUSE TRIP DEVICE

### GENERAL DESCRIPTION AND APPLICATION

The blown fuse trip device (three-coil shunt trip) is intended for use in applications where breakers and fuses are used in series. This accessory prevents single-phasing conditions by monitoring the fuses and automatically tripping the circuit breaker when a fuse blows. It does not protect from single-phasing of the power source.

Each coil of the blown fuse trip device is wired across a fuse so that the voltage across an open fuse is fed back to the accessory coil. When the coil is energized, the solenoid core releases the spring biased latch, allowing the slide to rotate the breaker latch tripping the breaker. The fuse must be replaced and the breaker reset before it can be reclosed.

If the breaker is closed on an open fuse, the blown fuse trip device will automatically open the circuit breaker.

### INSTALLATION

Installation of the blown fuse trip device is similar to the right-side shunt trip.

1. Breaker Cover Removal — follow steps 1-3 on page two. Be sure handle has been cranked twice before removing cover.
2. Remove the right-hand knockout, in the center pole of the breaker base, using screwdriver and hammer as shown in Fig.13. Remove all debris from breaker.

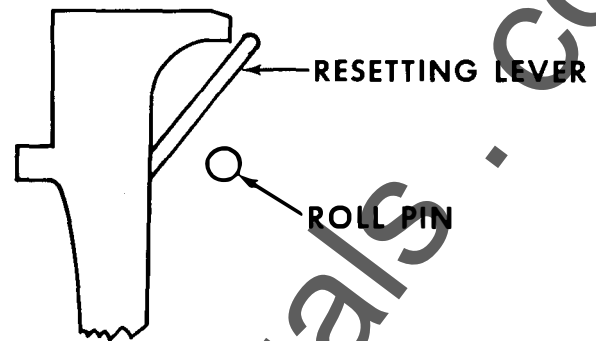

Fig. 11. Roll pin position

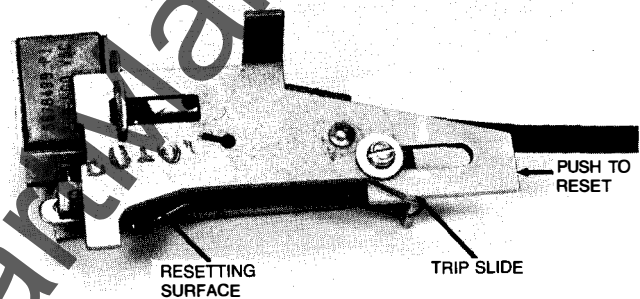

Fig. 12 Blown fuse trip device.

3. Refer to step 4a-4e on pages four and five and Fig. 6 to install blown fuse trip device.
4. Insert the wires and flexible sleeving from the blown-fuse trip device through the knockout hole in the breaker base and along the back for attachment as desired. See Fig. 9.

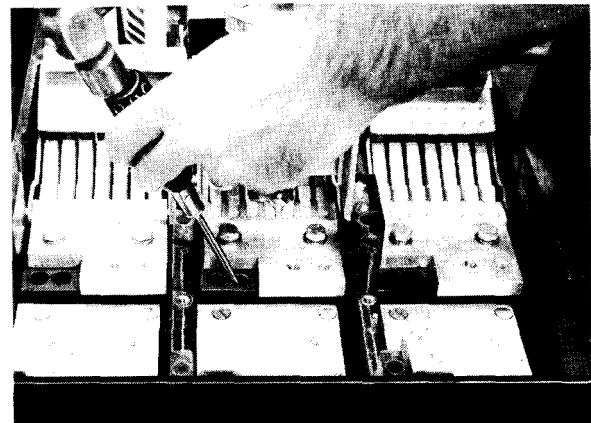

Fig. 13. Right knockout removal, center pole.

### Blown-Fuse Trip Device (cont'd.)

5. Install wire ties on wire bundle on the inside and outside of base to provide strain relief. See Fig. 8.
6. Perform installation checks listed below:
  - a. Replace the breaker cover. Close the breaker contacts.
  - b. To check electrical operation, apply 120 volts to one coil of the blown fuse trip device for not more than one second. The breaker must trip. Repeat the test for each coil.
7. Attach six (6) lead wires across each of the three fuses as shown in Fig. 14.
8. Apply the descriptive label to the front of the breaker cover.

### Cover Reassembly

Be sure cover (or covers) have been properly re-assembled. Refer to steps 1 and 2 on page 6.

### 3-POLE THREE-PHASE APPLICATION Blown Fuse Trip Device

Leads must be connected exactly as shown. Blown fuse trip device may not operate correctly if phase sequence or position is changed.

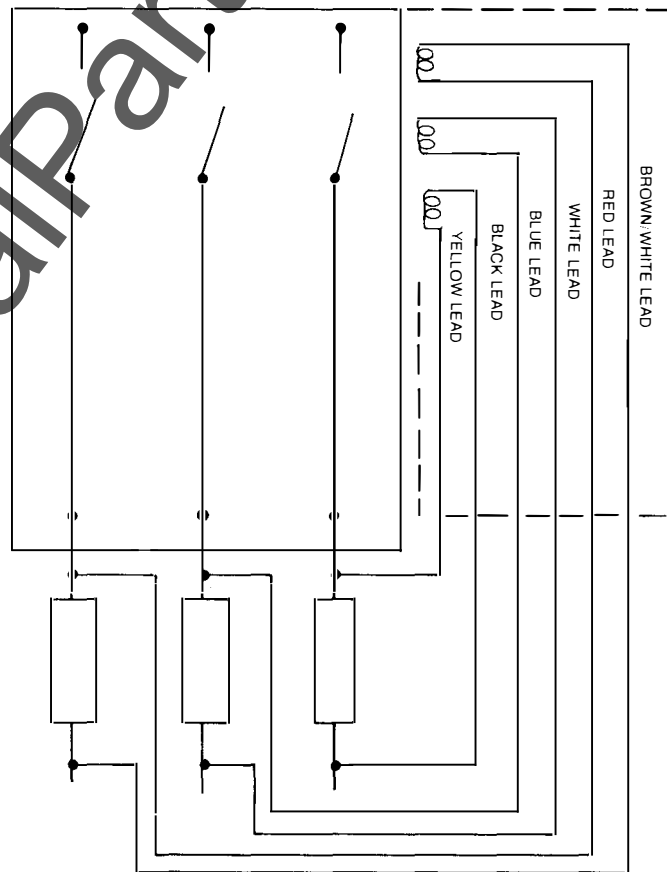

Fig. 14 Wiring diagram



## AUXILIARY SWITCH

### DESCRIPTION

The auxiliary switch is used for remote indication of breaker main contact position — OPEN or CLOSED. No distinction is made between an open or tripped mode. A maximum of 12 switches can be installed per breaker. Each is single-pole, double-throw (AB-type) and rated as shown in table below. Two switch positions must be devoted to each shunt trip accessory (if used).

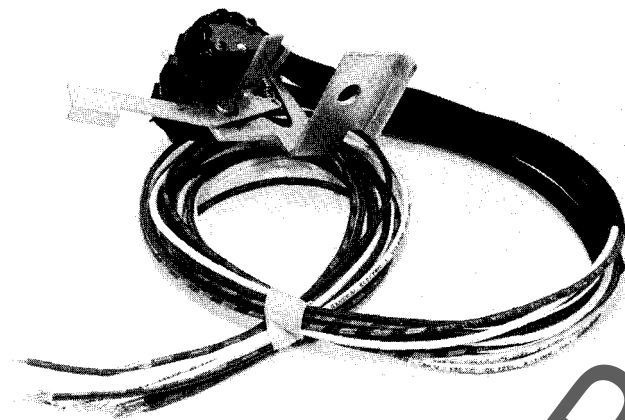

Fig. 15. Auxiliary switch

### ELECTRICAL DATA

#### AUXILIARY SWITCH KITS

Voltage 240V ac max. 250V dc max.	Number of Switch Elements	Maximum Ampere Rating Switch Elements
TSAS2AB*	1-12	6A at 240 Vac 1/4A at 250 volts dc 1/2A at 125 volts dc

\*Suffix numbers 1 through 12 designate number of switch elements

### INSTALLATION

1. Refer to circuit breaker cover removal instructions on page two.
2. Remove appropriate knockout(s) in the breaker base using screwdriver and hammer as shown in Fig. 16. Remove all debris from the breaker.
3. Remove the left hex-head bolt. Discard the plain washer, and install the switch assembly as shown in Fig. 17, using bolt and lockwasher. Torque the bolt to 30 inch-pounds while holding the unit in the correct position.
4. Insert leads and flexible sleeving through the knockout(s) (maximum three bundles per knockout) and along back of breaker to desired connection point. Leads of respective stages should be identified to ensure proper connection after the breaker cover has been replaced and the breaker installed.

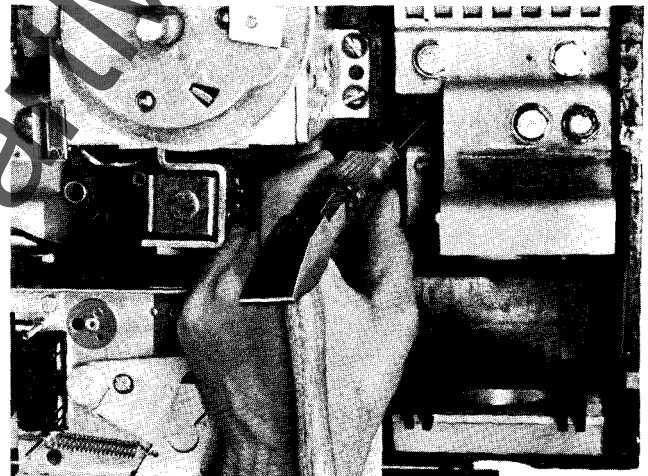

Fig. 16.

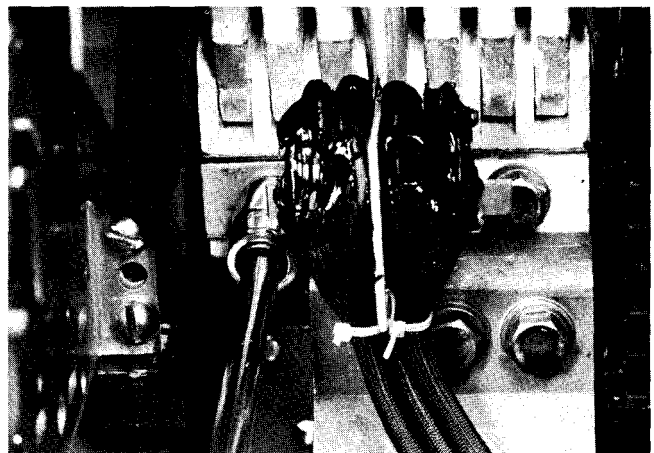

Fig. 17.

5. Install wire ties on wire bundle(s) on the inside and outside of base to provide strain relief. See Fig. 8.
6. Replace breaker cover (or covers for electrically operated breaker)
7. Perform installation checks:
  - a. Verify that "A" contacts Fig. 18. (red and white leads) are open when breaker is open.
  - b. Verify that "B" contacts (brown/white and white leads) are closed when the breaker is open.

- c. Verify that above circuit conditions are reversed when breaker is closed.
- d. Following field installation, apply the descriptive label to the front of the breaker cover.

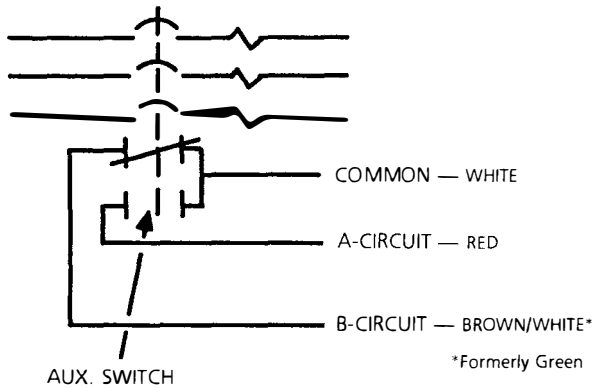

Fig. 18

**NOTE:** If the breaker was removed from its supporting structure, use tape to hold the wires in the wiring channel as shown in Fig. 9, to assure that no wires are pinched under the breaker mounting pads.

#### 4000A Power Break with MagneTrip Non-Interchangeable Trip

Installation of any of these accessories in a 4000A frame MagneTrip requires removal of sealant from one cover screw. Such modification voids the UL Listing. Remove and discard the UL label.

[www.ElectricalPartManuals.com](http://www.ElectricalPartManuals.com)

www.ElectricalPartManuals.com

*These instructions do not purport to cover all details or variations in equipment nor to provide for every possible contingency to be met in connection with installation operation or maintenance. Should further information be desired or should particular problems arise which are not covered sufficiently for the purchaser's purposes, the matter should be referred to the General Electric Company.*

For further information  
call or write your local  
General Electric  
Sales Office or...

Distribution Equipment  
Division  
41 Woodford Avenue  
Plainville, CT 06062

**GENERAL**  **ELECTRIC**