



RENEWAL PARTS

Type AM-4.16-250 Magne-Blast Circuit Breakers

Note: The ML-13 operating mechanism is not included in this publication.
Refer to GEF-4379.

Ordering Instructions

1. Always specify the complete nameplate data of the breaker.
2. Specify the quantity, catalog number (if listed), reference number (if listed) description, and this bulletin number.
3. Standard hardware, such as screws, bolts, nuts, washers, etc., is not listed in this bulletin. Such items should be purchased locally.
4. For prices, refer to the nearest office of the General Electric Company.

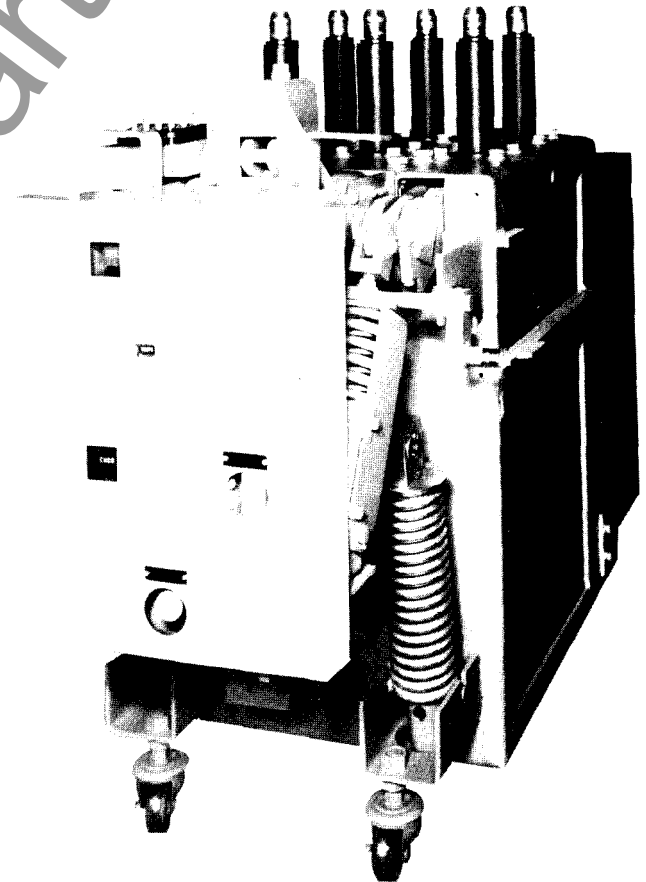

TYPE AM-4.16 MAGNE-BLAST CIRCUIT BREAKERS

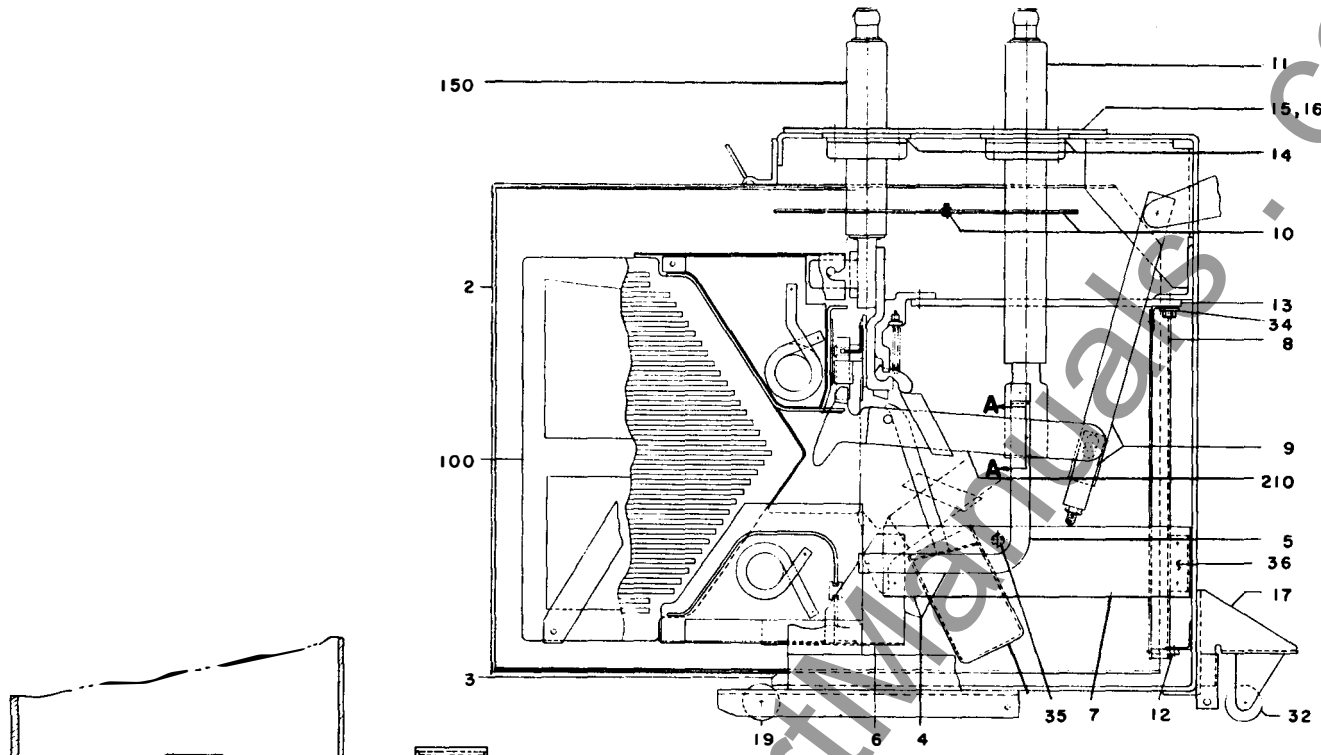

A. Breaker, Type AM-4.16-4

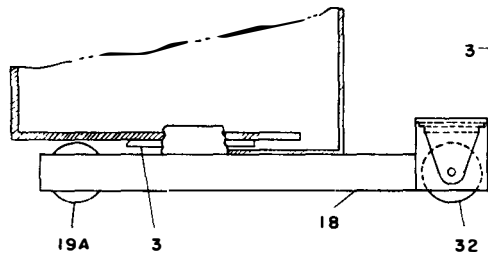

B. Barrier support

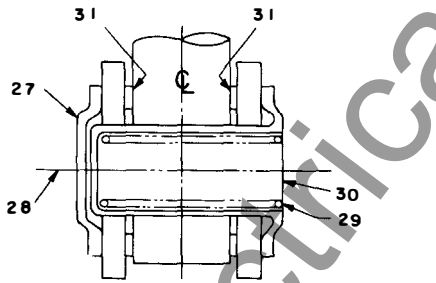

(1200 amp)

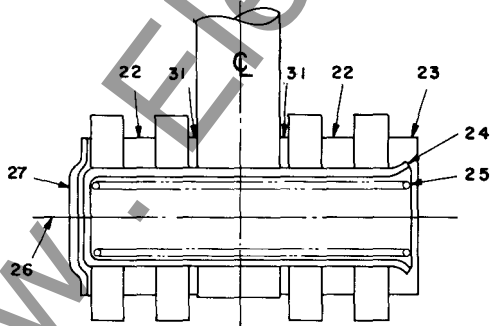

(2000 amp)

C. Hinge assembly (See Section A-A)

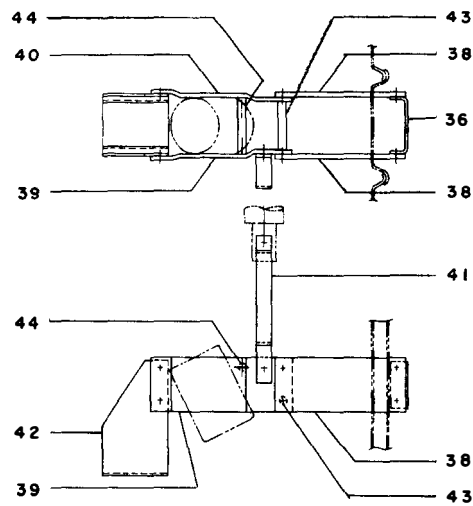

D. Cylinder support

Fig. 1. Cross section views

TYPE AM-4.16 MAGNE-BLAST CIRCUIT BREAKERS

GEF-4426

Type AM-4. 16-250 Magne-blast Circuit Breaker (Refer to Fig. 1)

Ref. No.	Ampere Rating	Catalog Number for AM-4, 16			No. Reqd.	Description
		-6H and -6C	-7H and -7C	-8H and -8C		
1	All	733-0619C0444G005	733-0619C0444G005	733-0619C0444G005	3	Booster cylinder
2	All	0114C5388G001	0114C5388G001	0114C5388G001	1	Box barrier assembly
3	All	*	*	*	*	Box barrier guide
4	All	0137A6025G001	----	----	3	Arc chute support assembly
5	All	0258C0619P008	----	----	3	Connection bar
6	All	0619C0444G003	----	----	3	Arc chute clamp
7	All	0137A6001P001	----	----	3	Arc chute support, left
7	All	0137A6001P002	----	----	3	Arc chute support, right
8	All	0619C0461G005	0619C0461G012	0619C0461G012	1	Vertical barrier, left
8	All	0619C0461G002	0619C0461G011	0619C0461G011	1	Vertical barrier, center
8	All	0619C0461G010	0619C0461G010	0619C0461G010	1	Vertical barrier, right
9	All	0281B0708G002	0281B0708G002	0281B0708G002	3	Operating rod
10	1200	0258C0614P006	0258C0614P006	0258C0614P006	6	Horizontal barrier, upper
10	2000	0258C0614P007	0258C0614P007	0258C0614P007	6	Horizontal barrier, upper
11	1200	0845D0123G001	0845D0123G001	0845D0123G001	3	Bushing, long
11	2000	0688C0515G001	0688C0515G001	0688C0515G001	3	Bushing, long
12	All	0619C0461P026	0619C0461P026	0619C0461P026	3	Block
13	1200	0688C0575P011	0114C5380P011	0114C5380P011	6	Horizontal barrier, lower
13	2000	0688C0575P012	0114C5380P012	0114C5380P012	6	Horizontal barrier, lower
14	1200	0688C0575P009	----	----	6	Spacer
15	1200	0258C0614P020	0258C0614P020	0258C0614P020	4	Cover plate
16	2000	0619C0444P029	0619C0444P029	0619C0444P029	1	Top plate
17	All	0635D0390G001	0635D0390G001	0635D0390G001	1	Wheel assembly, complete
18	∅	0236C0767G007	0236C0767G007	0236C0767G007	1	Wheel assembly, complete
19	All	006597296P008	006597296P008	006597296P008	2	Wheel and spanner bushing
19A	∅	006597296P006	006597296P006	006597296P006	2	Wheel and spanner bushing
20	1200	0898B0282G001	0898B0282G001	0898B0282G001	3	Hinge point assembly
21	2000	0898B0282G002	0898B0282G002	0898B0282G002	3	Hinge point assembly
22	2000	006442246P001	006442246P001	006442246P001	6	Spacer
23	2000	006441630P001	006441630P001	006441630P001	3	Washer
24	2000	006442257P001	006442257P001	006442257P001	3	Bearing
25	2000	0369A0407P001	0369A0407P001	0369A0407P001	3	Spring
26	2000	0414A0106P007	0414A0106P007	0414A0106P007	3	Bolt
27	All	006444617P001	006441617P001	006441617P001	3	Washer
28	1200	0414A0106P004	0414A0106P004	0414A0106P004	3	Screw
29	1200	0421A0239P001	0421A0239P001	0421A0239P001	3	Spring
30	1200	0137A9186P001	0137A9186P001	0137A9186P001	3	Bearing
31	All	0456A0884P001	0456A0884P001	0456A0884P001	6	Hinge washer
32	All	0456A0862P009	0456A0862P009	0456A0862P009	2	Front wheel and caster
†33	All	0105C9317G1	0105C9317G001	0105C9317G001	1	Mechanism cover
34	All	0619C0461P025	0619C0461P025	0619C0461P025	3	Plate
35	All	006176110P441	----	----	6	Spacer, 3 3/4 inch
36	All	0619C0444P006	0619C0444P006	0619C0444P006	3	Support
†37	All	0137A9103P001	----	----	3	Booster cylinder jumper
38	All	0688C0575P001	0114C5380P003	0114C5380P003	6	Support
39	All	0688C0575P002	0114C5380P001	0114C5490P001	3	Support, left
40	All	0688C0575P003	0114C5380P002	0114C5490P002	3	Support, right
41	All	0688C0575P004	0114C5380P004	0114C5490P003	3	Connection bar
42	All	0619C0444G004	0619C0444G003	0619C0444G003	3	Arc chute clamp
43	All	0421A0209P429	0421A0209P429	0421A0209P429	3	Spacer
44	All	0421A0209P447	0421A0209P447	0421A0209P447	3	Spacer

† Not illustrated.

∅ For breaker model list with W suffix.

▲ For Type -6H and -6C only. Order Ref. No. 38 through 44 when individual parts are required. If the complete assembly is required order Ref. No. 4 which includes parts 38 through 44.

* (For box barrier with fabricated top, order quantity of (2) Cat. No. 0258C0614P037.

(For box barrier with molded top, order quantity of (2) Cat. No. 0114C5381P006.

TYPE AM-4.16 MAGNE-BLAST CIRCUIT BREAKERS

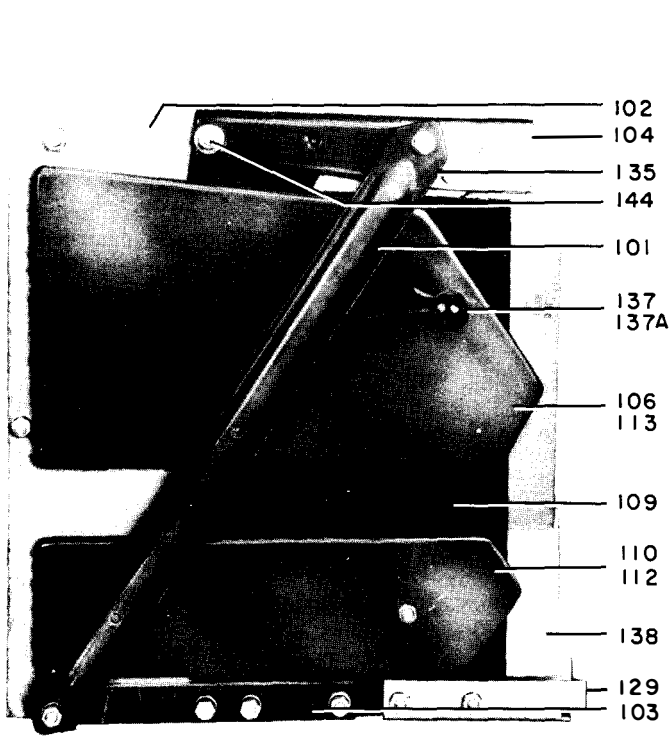

A. Complete arc chute assembly "-6" design

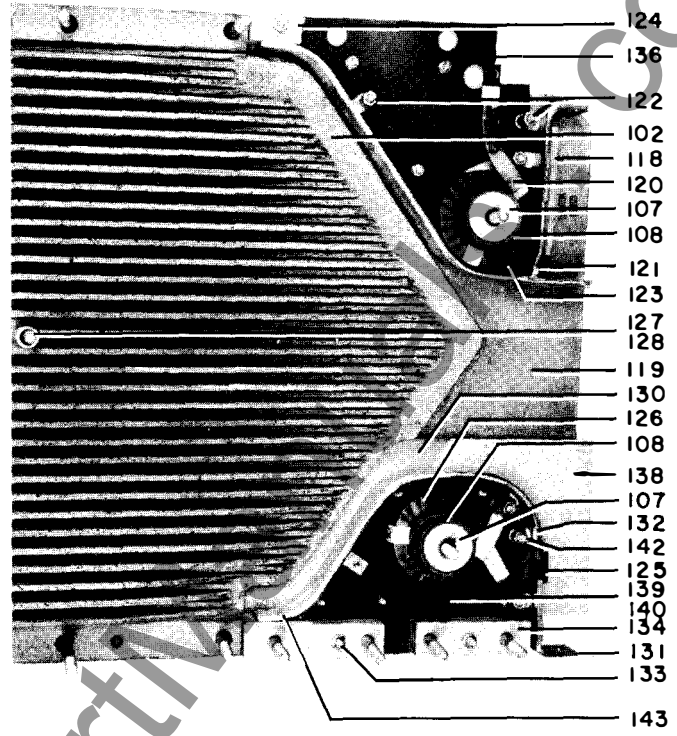

B. Side cover removed "-6" design

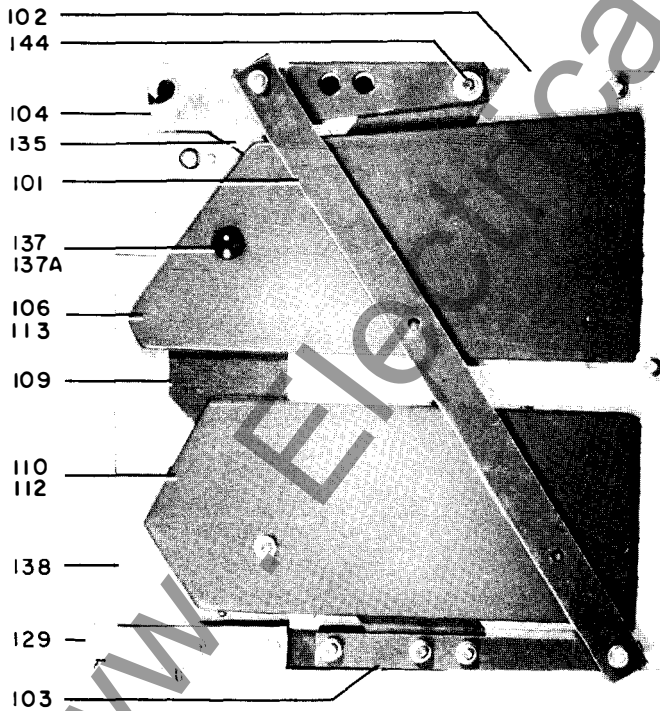

C. Complete arc chute assembly "-7" and "-8" design

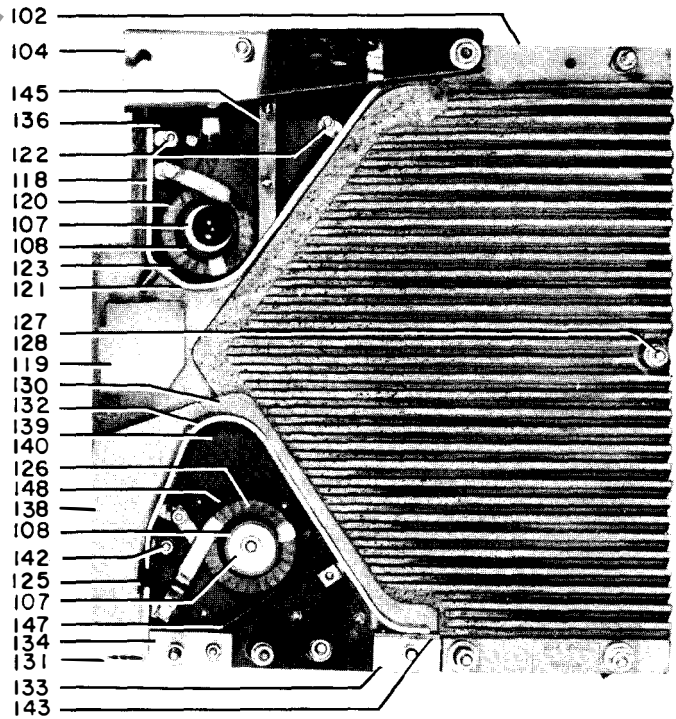

D. Side cover removed "-7" and "-8" design

Fig. 2. Arc chute

TYPE AM-4.16 MAGNE-BLAST CIRCUIT BREAKERS

GEF-4426

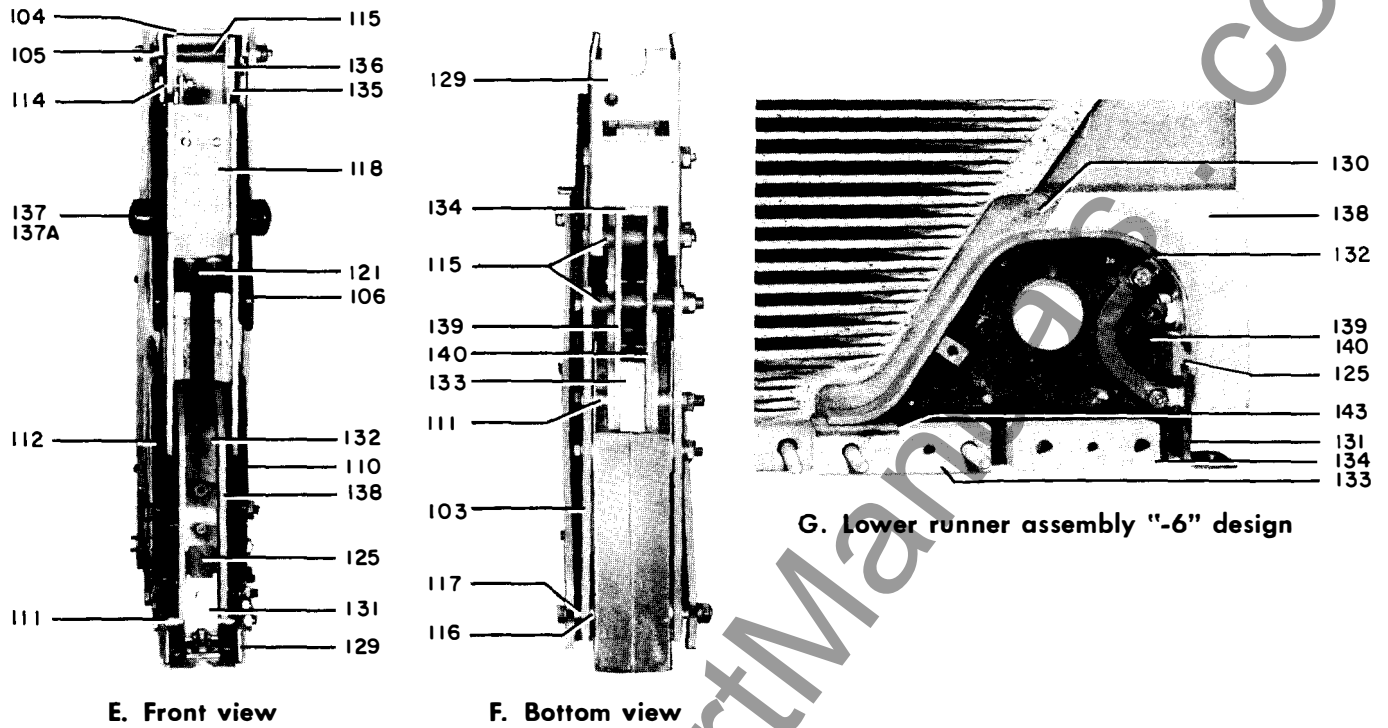

Fig. 2. Arc chute (cont'd.)

Arc Chute Assembly (Refer to Fig. 2)

Ref. No.	Catalog Number for Type AM-4.16			No. Reqd.	Description
	-6H and -6C	-7H and -7C	-8H and -8C		
100	733-0215D0469G002	733-0213X0416G001	733-0213X0416G010	3	Arc chute assembly
101	0456A0381P002	0456A0381P003	0456A0381P003	6	Brace
102	0264B0100G003	0264B0100G003	0264B0100G003	3	Arc chute sides
103	0258C0616P004	0258C0616P004	0258C0616P004	6	Lower support
104	0215D0469G050	0215DX0416G004	0213X0416G016	3	Upper support
105	0421A0208P078	006176109P072	006176109P078	6	Spacer
106	0258C0615G002	0836C0197G004	0836C0197G004	3	Upper pole piece, right
107	0258C0615P029	0258C0615P019	0258C0615P031	3	Core, upper
107	0258C0615P019	0258C0615P030	0258C0615P030	3	Core, lower
108	0258C0616P018	0258C0616P023	0258C0615P025	3	Core insulation, upper
108	0258C0616P023	0258C0616P024	0258C0616P024	3	Core insulation, lower
109	0107B9365P001	0114C5381P002	0114C5381P002	6	Shield
110	0258C0615G006	0836C0197G002	0836C0197G002	3	Lower pole piece, right
111	0421A0208P093	----	----	24	Spacer
111	----	0421A0208P093	0421A0208P093	12	Spacer
112	0258C0615G003	0836C0197G001	0836C0197G001	3	Lower pole piece, left
113	0258C0615G001	0836C0197G003	0836C0197G003	3	Upper pole piece, left
114	0258C0615P011	0258C0615P011	0258C0615P011	3	Connection
115	0421A0209P082	----	----	3	Spacer
115	----	0456A0888P005	0456A0888P005	9	Spacer
116	000432249P001	000432249P001	00432249P001	6	Spacer
117	006176109P072	006176109P072	006176109P072	6	Spacer
118	0414A0116P002	0114C5381P003	0414A0116P002	3	Insulation plate
119	0414A0117P001	----	----	6	Throat insulation
119	----	0108B1965G001	0195A7377G001	3	Throat insulation, right
119	----	0108B1965G002	0195A7377G002	3	Throat insulation, left
120	0366A0743G001	0366A0743G001	0366A0743G001	3	Coil, upper
121	0258C0632G001	0962C0745G001	0962C0745G001	3	Runner assembly, upper
122	0421A0208P024	0421A0208P024	0421A0208P024	12	Spacer
123	0456A0891P210	0456A0891P210	0456A0891P210	3	Insulation strip
124	0258C0616P005	0258C0616P005	0258C0616P005	3	Spacer
125	0258C0616P011	0258C0616P011	0258C0616P011	3	Spacer

TYPE AM-4.16 MAGNE-BLAST CIRCUIT BREAKERS

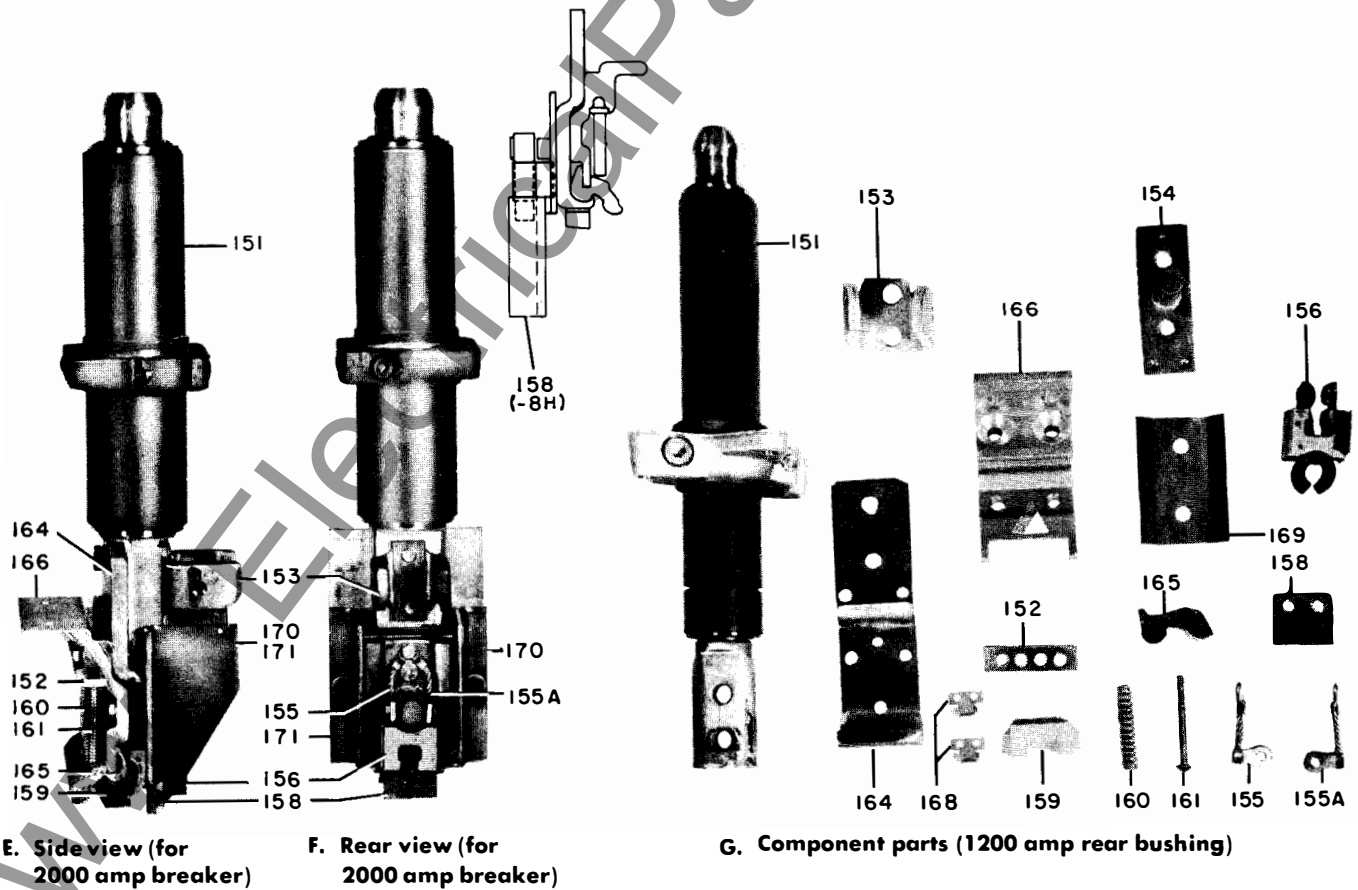
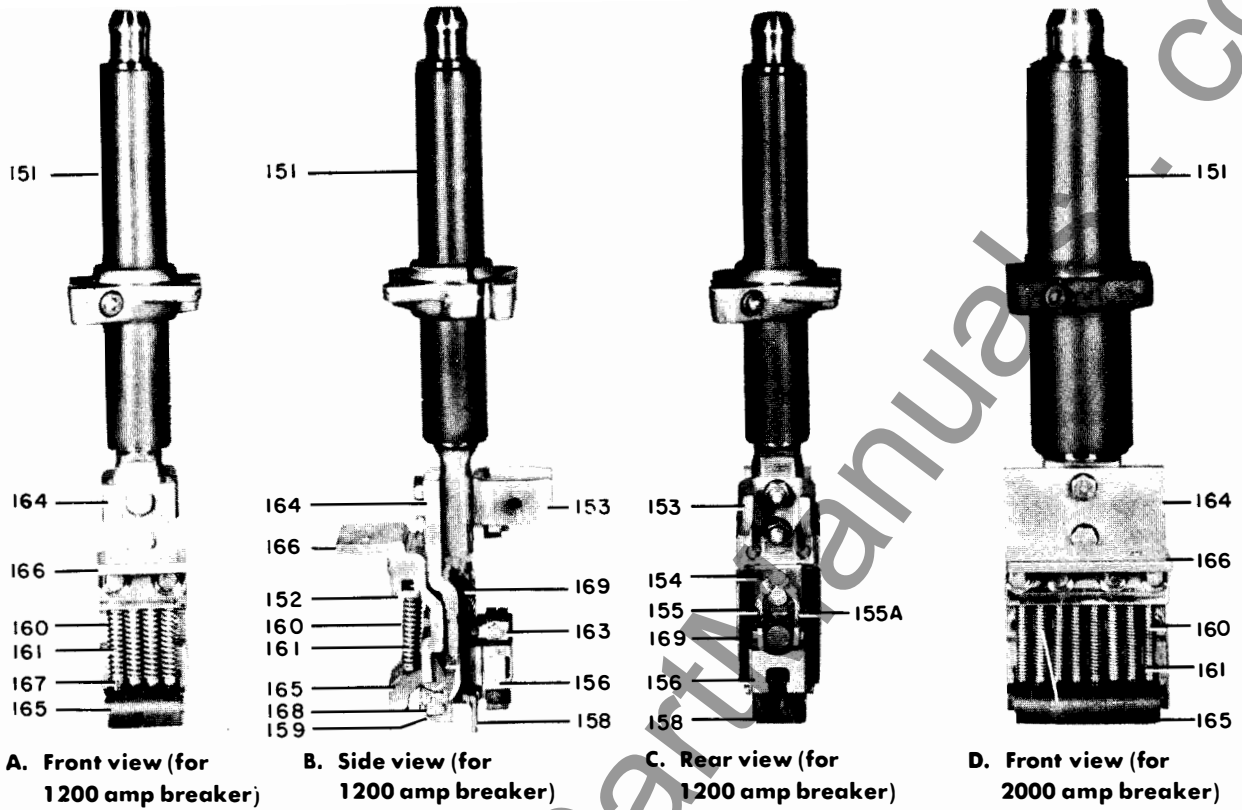

Fig. 3. Rear bushing assembly (Ref. No. 150)

TYPE AM-4.16 MAGNE-BLAST CIRCUIT BREAKERS

GEF-4426

Arc Chute Assembly (Refer to Fig. 2) (Cont'd)

Ref. No.	Catalog Number for Type AM-4.16			No. Reqd.	Description
	-6H and -6C	-7H and -7C	-8H and -8C		
126	733-0366A0744G001	733-0366A0744G001	733-0366A0744G001	3	Coil, lower
127	0414A0131P004	0958C0604P012	0958C0604P012	AR	Shim
128	006445050P010	006445050P010	006445050P010	3	Spacer
129	0258C0615P015	0258C0615P015	0258C0615P015	3	Support
130	0383A0932P001	0161A5906P001	0161A5906P001	6	Lower shield
131	0258C0615G005	0258C0615G005	0258C0615G005	3	Connection assembly
132	0258C0615G004	0836C0198G002	0836C0198G002	3	Runner assembly, lower
133	0258C0616P022	0958C0604P004	0958C0604P004	3	Spacer
134	0258C0616P021	0958C0604P005	0958C0604P005	3	Spacer
135	0258C0616P009	0836C0197P014	0836C0197P014	6	Upper insulation
136	0258C0632P010	0836C0197P013	0836C0197P013	6	Barrier
137	000421711P001	000421711P001	000421711P011	6	Insulating cap
137A	000407193P001	000407193P001	000407193P001	6	Washer for insulating cap (Ref. 137)
138	0258C0616P006	0114C5381P001	0114C5381P010	6	Lower barrier
139	0258C0616P007	0836C0197P012	0836C0197P012	3	Barrier, left
140	0258C0616P008	0836C0197P011	0836C0197P011	3	Barrier, right
142	0421A0208P010	0421A0208P010	0421A0208P010	6	Spacer
143	0414A0198P001	0114C5381P005	0114C5381P005	3	Insulation
144	0137A9163P002	0137A9163P002	0137A9163P002	6	Insulating bushing
145	----	0958C0604P002	0958C0604P002	3	Barrier
146	----	0836C0197P015	0836C0197P015	6	Cup washer
147	----	0958C0604P006	0958C0604P006	3	Barrier
148	----	0456A8091P219	0456A8091P219	3	Insulation strip

Rear Bushing Assembly (Refer to Fig. 3)

Ref. No.	Ampere Rating	Catalog Number for Type AM-4.16			No. Reqd.	Description
		-6H and -6C	-7H and -7C	-8H and -8C		
150	1200	733-0254D0754G020	733-0236C0790G107	733-0213X0344G003	3	Rear bushing assembly
150	2000	0254D0754G015	0236C0790G108	0213X0344G004	3	Rear bushing assembly
151	1200	0688C0581G003	0688C0581G003	0845D0124G001	3	Rear bushing, short
151	2000	0688C0516G001	0688C0516G006	0688C0516G006	3	Rear bushing, short
152	1200	0828C0782P004	0962C0778P007	0962C0778P007	3	Spring retainer strip
152	2000	0828C0782P005	0962C0778P007	0962C0778P007	3	Spring retainer strip
153	1200	0236C0791P017	0619C0443P017	0619C0443P017	3	Arc chute support
153	2000	0236C0791P019	0619C0443P008	0619C0443P008	3	Arc chute support
154	All	0236C0791G003	0236C0791G003	0236C0791G003	3	Arcing contact support
155	All	0236C0791G001	0236C0791G001	0236C0791G001	3	Flexible connection, right
155A	All	0236C0791G004	0236C0791G004	0236C0791G004	3	Flexible connection, left
156	All	0236C0790G009	0236C0790G009	0236C0790G009	3	Arcing contact assembly
158	All	0414A116P004	0414A0116P004	----	3	Insulating plate
158A	All	----	----	0195A7388G002	3	Barrier assembly
159	All	006445087P004	006445087P004	006445087P004	3	Buffer
160	1200	0121A5964P001	----	----	12	Spring
160	1200	----	0121A5964P001	0121A5964P001	18	Spring
160	2000	006509787P001	----	----	24	Spring
160	2000	----	0121A5964P001	0121A5964P001	18	Spring
161	1200	N312P2542B	----	----	12	Spring guide
161	2000	N312P2542B	----	----	24	Spring guide
161	All	----	N312P2542B	N312P2542B	18	Spring guide
163	All	0175V0557P001	0175V0557P001	0175V0557P001	6	Locking plate
164	1200	0258C0666P009	----	----	3	Contact support
164	2000	----	0962C0778P011	0962C0778P011	3	Contact support
165	1200	0236C0791P008	----	----	12	Primary contact finger
165	2000	0236C0791P008	----	----	24	Primary contact finger
165	All	----	0114C5382P002	0114C5382P002	18	Primary contact finger
166	1200	0828C0782P013	0962C0778P002	0962C0778P002	3	Primary contact finger retainer
166	2000	0828C0782P008	0962C0778P002	0962C0778P002	3	Primary contact finger retainer
167	1200	006176109P006	----	----	12	Spacer
167	All	----	006176109P006	006176109P006	18	Spacer
168	1200	006557243P001	006176109P002	006557243P002	6	Buffer clamp
168	2000	006557243P002	006176109P002	006557243P002	6	Buffer clamp
169	All	0265C0151P025	----	----	3	Spring baffle
170	2000	0258C0632P008	----	----	3	Copper plate, left-hand
171	2000	0258C0632P009	----	----	3	Copper plate, right-hand

www.ElectricalPartManuals.com

GENERAL ELECTRIC COMPANY • BREAKER PLANT OPERATION • PHILADELPHIA, PA 19142

12-84 (500)

GENERAL  **ELECTRIC**

TYPE AM-4.16 MAGNE-BLAST CIRCUIT BREAKERS

GEF-4426

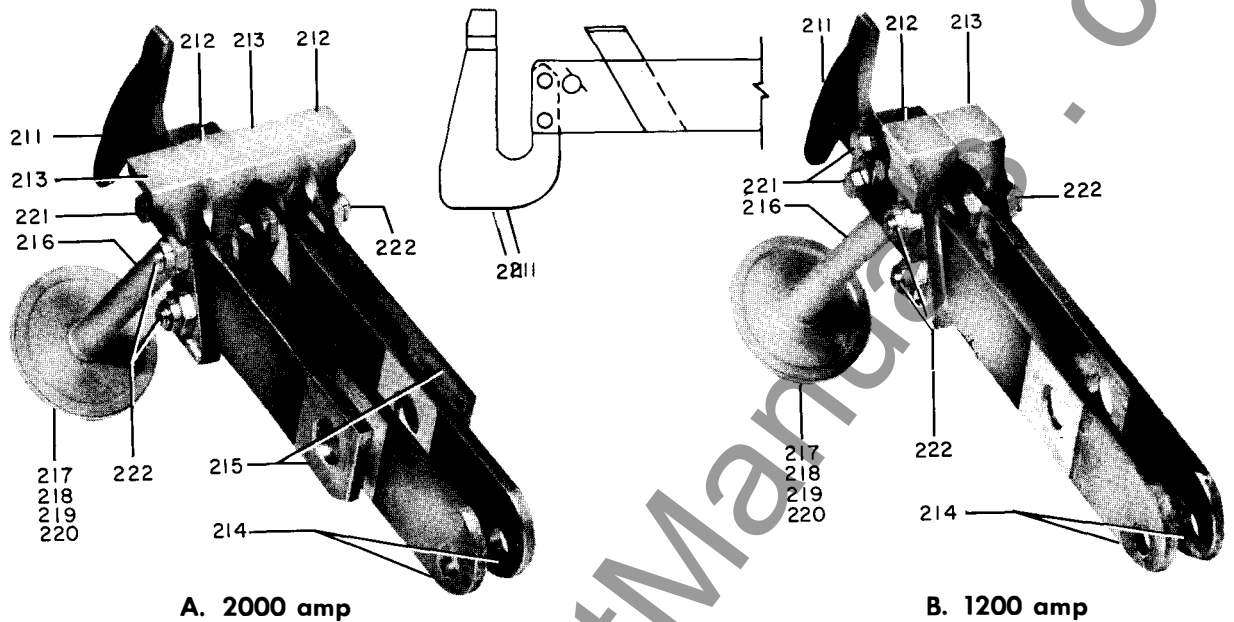

Fig. 4. Movable contact arm assembly (Ref. No. 210)

Movable Contact Arm Assembly (Refer to Fig. 4)

Ref. No.	Ampere Rating	Catalog Number for Type AM-4.16			No. Reqd.	Description
		-6H and -6C	-7H and -7C	-8H and -8C		
210	1200	733-0213X0343G030	733-0213X0343G041	733-0213X0343G077	3	Movable contact arm assembly
210	2000	0213X0343G031	0213X0343G042	0213X0343G078	3	Movable contact arm assembly
211	All	0802B0742G001	0802B0742G001	0227A5306G004	3	Arcing tip
212	1200	0137A9164P003	----	----	3	Movable primary contact
212	2000	0137A9164P003	----	----	6	Movable primary contact
213	1200	0137A9164P004	----	----	3	Movable primary contact
213	2000	0137A9164P004	----	----	6	Movable primary contact
213	All	----	0114C5382P004	0114C5382P004	6	Movable primary contact
214	All	0258C0666P007	0258C0666P007	0258C0666P007	6	Contact arm
215	2000	0258C0666P006	0258C0666P006	0258C0666P006	6	Contact arm
216	1200	0213X0343G043	0213X0343G043	0213X0343G090	3	Tube and piston assembly
216	2000	0213X0343G044	0213X0343G044	0213X0343G091	3	Tube and piston assembly
217	All	0421A0248P001	0421A0248P001	0421A0248P001	3	Piston ring
218	All	0456A0874P003	0456A0874P003	0456A0874P003	3	Piston ring equalizer
219	1200	0456A0874P002	0456A0874P002	0456A0874P002	3	Shim
219	2000	0456A0874P002	0456A0874P002	0456A0874P002	6	Shim
220	All	0258C0619P006	0258C0619P006	0258C0619P006	3	Orifice
221	All	0414A0146P053	0414A0146P053	0414A0146P053	6	Grip nut
222	All	0414A0146P054	0414A0146P054	0414A0146P054	12	Grip nut
†223	All	0456A0876P208	0456A0876P208	0456A0876P207	12	Spacer

† Not illustrated.

TYPE AM-4.16 MAGNE-BLAST CIRCUIT BREAKERS

GEF-4426

PARTS RECOMMENDED FOR NORMAL MAINTENANCE

Fig. No.	Ref. No.	Ampere Rating	Catalog No. for Type AM-4.16			No. Req'd	Description
			-6H and -6C	-7H and -7C	-8H and -8C		
1	9	ALL	733-0281B0708G002	733-0281B0708G002	733-0281B0708G002	3	Operating rod
2	118	ALL	0414A0116P002	0114C5381P003	0414A0116P002	3	Insulating plate
2	119	ALL	0414A0117P001	---	---	6	Throat insulation
2	119	ALL	---	0108B1965G001	0195A7377G001	3	Throat insulation, right
2	119	ALL	---	0108B1965G002	0195A7377G002	3	Throat insulation, left
2	130	ALL	0383A0932P001	0161A5906P001	0161A5906P001	6	Lower shield
2	135	ALL	0258C0616P009	0836C0197P014	0836C0197P014	6	Upper insulation
2	137	ALL	000421711P001	000421711P001	000421711P001	6	Insulating cap
2	137A	ALL	000407193P001	000407193P001	000407193P001	6	Washer for insulating cap (Ref. 137)
2	138	ALL	0258C0616P006	0114C5381P001	0114C5381P010	6	Lower barrier
3	155	ALL	0236C0791G001	0236C0791G001	0236C0791G001	3	Flexible connection, right
3	155A	ALL	0236C0791G004	0236C0791G004	0236C0791G004	3	Flexible connection, left
3	156	ALL	0236C0790G009	0236C0790G009	0236C0790G009	3	Arcing contact assembly
3	158	ALL	0414A0116P004	0414A0116P004	---	3	Insulating plate
3	160	1200	0121A5964P001	---	---	12	Primary contact finger spring
3	160	1200	---	0121A5964P001	0121A5964P001	18	Primary contact finger spring
3	160	2000	006509787P001	---	---	24	Primary contact finger spring
3	160	2000	---	0121A5964P001	0121A5964P001	18	Primary contact finger spring
3	165	1200	0236C0791P008	---	---	12	Primary contact finger
3	165	2000	0236C0791P008	---	---	24	Primary contact finger
3	165	ALL	---	0114C5382P002	0114C5382P002	18	Primary contact finger
4	211	ALL	0802B0742G001	0802B0742G001	0108B5506G001	3	Arcing tip
4	212	1200	0137A9164P003	---	---	3	Movable primary contact
4	212	2000	0137A9164P003	---	---	6	Movable primary contact
4	213	1200	0137A9164P004	---	---	3	Movable primary contact
4	213	2000	0137A9164P004	---	---	6	Movable primary contact
4	213	ALL	---	0114C5382P004	0114C5382P004	6	Movable primary contact
4	216	1200	0213X0343G043	0213X0343G043	0213X0343G090	3	Tube and piston assembly
4	216	2000	0213X0343G044	0213X0343G044	0213X0343G091	3	Tube and piston assembly