

March 2002

Contents

<i>Description</i>	<i>Page</i>
<i>IT. Electro-Mechanical Line</i>	
Product Family Overview	34-2
Contactors — Full Voltage Non-reversing and Reversing	34-4
Starters — Full Voltage Non-reversing and Reversing	34-7

Note: Supplement to Publication No. CA08102001E.

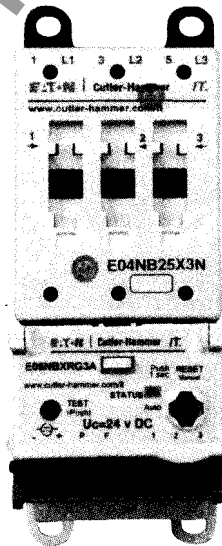

**IEC IT. Full Voltage
Non-reversing Starter**

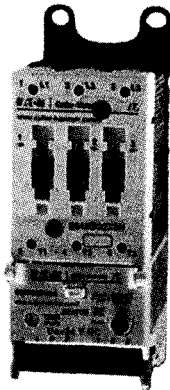

IEC, B Frame, 20 hp/460V
Non-reversing Starter

34

Product Description

Eaton's Cutler-Hammer Intelligent Technologies (IT.) Electro-Mechanical line of Contactors and Starters is the result of a substantial engineering, manufacturing and marketing effort involving extensive customer input, combined with new advances in solid-state technology. IT. Electro-Mechanical products have greatly increased functionality, significantly reduced size and utilize the benefits of 24V DC control. The exclusive Pulse Width Modulation (PWM) control and digital microprocessor generate a minimized DC value which reduces energy to the contact block and provides the most compact system available.

Standards and Certifications

- Standard: Designed to meet or exceed UL, IEC and CSA
- UL Listed: UL File #E1491, Guide #NLDX — Open, UL 508
- CSA Certified: CSA File #156828, Class #3211 04 Open, C22.2 No. 14-95
- IEC: A – F Frames, IEC 60947-4-1, EN 60947-4-1
- CSA Elevator Ratings
- CE
- EMC IEC 61000-4
- KEMA

ISO 9002 Certification

When you turn to Eaton's Cutler-Hammer Products, you turn to quality. The International Standards Organization (ISO) has established a series of standards acknowledged by 91 industrialized nations to bring harmony to the international quest for quality. The ISO Certification process covers 20 quality system elements in design, production and installation that must conform to achieve registration. This commitment to quality will result in increased product reliability and total customer satisfaction.

Instructional Leaflets

- 49600 IT. IEC Overload Relay Setup and Troubleshooting Manual
- 50200 IT. NEMA Contactor and Starter User Manual
- 49602 IT. IEC Overload Relay (B – F Frame) Quick Setup Guide
- 49320 IT. IEC Non-reversing Contactor 27 mm (A-Frame) Installation Guide
- 49640 IT. IEC Non-reversing Contactor 45 mm (B-Frame) Installation Guide
- 49650 IT. IEC Non-reversing Contactor 54 mm (C-Frame) Installation Guide
- 49660 IT. IEC Non-reversing Contactor 76 mm (D-Frame) Installation Guide
- 49670 IT. IEC Non-reversing Contactor 105 mm (E-Frame) Installation Guide
- 49680 IT. IEC Non-reversing Contactor 140 mm (F-Frame) Installation Guide
- 49321 IT. IEC Reversing Contactor 27 mm (A-Frame) Installation Guide
- 49641 IT. IEC Reversing Contactor 45 mm (B-Frame) Installation Guide
- 49651 IT. IEC Reversing Contactor 54 mm (C-Frame) Installation Guide
- 49661 IT. IEC Reversing Contactor 76 mm (D-Frame) Installation Guide
- 49671 IT. IEC Reversing Contactor 105 mm (E-Frame) Installation Guide
- 49681 IT. IEC Reversing Contactor 140 mm (F-Frame) Installation Guide
- 49642 IT. IEC Non-reversing Starter 45 mm (B-Frame) Installation Guide
- 49652 IT. IEC Non-reversing Starter 54 mm (C-Frame) Installation Guide
- 49662 IT. IEC Non-reversing Starter 76 mm (D-Frame) Installation Guide
- 49672 IT. IEC Non-reversing Starter 105 mm (E-Frame) Installation Guide
- 49682 IT. IEC Non-reversing Starter 140 mm (F-Frame) Installation Guide
- 49643 IT. IEC Reversing Starter 45 mm (B-Frame) Installation Guide
- 49653 IT. IEC Reversing Starter 54 mm (C-Frame) Installation Guide
- 49663 IT. IEC Reversing Starter 76 mm (D-Frame) Installation Guide
- 49673 IT. IEC Reversing Starter 105 mm (E-Frame) Installation Guide
- 49683 IT. IEC Reversing Starter 140 mm (F-Frame) Installation Guide
- 49410 IT. Front Mountable Auxiliary Contact Assembly Instructions
- 49645 IT. Non-reversing Contactor Assembly Instructions (45 mm & 54 mm)
- 49665 IT. Non-reversing Contactor & Starter Assembly Instructions (76 mm Contactor/Starter) (45 mm & 54 mm Starter)

For copies of these and other publications, contact the Literature Fulfillment Center at 800-957-7050, Fax: 877-840-2371 or find on-line at: www.cutler-hammer.eaton.com/it.

For International, call: (630) 377-9738 (English only), Fax: (630) 377-1753.

E-mail: wcsorders@wallace.com

Mail: Cutler-Hammer Fulfillment Center
1750 Wallace Avenue
St. Charles, IL 60174-3404

March 2002

IT. Electro-Mechanical Line

Catalog Number Selection (Open Components)

Table 34-1. *IT*. Electro-Mechanical Catalog Numbering System

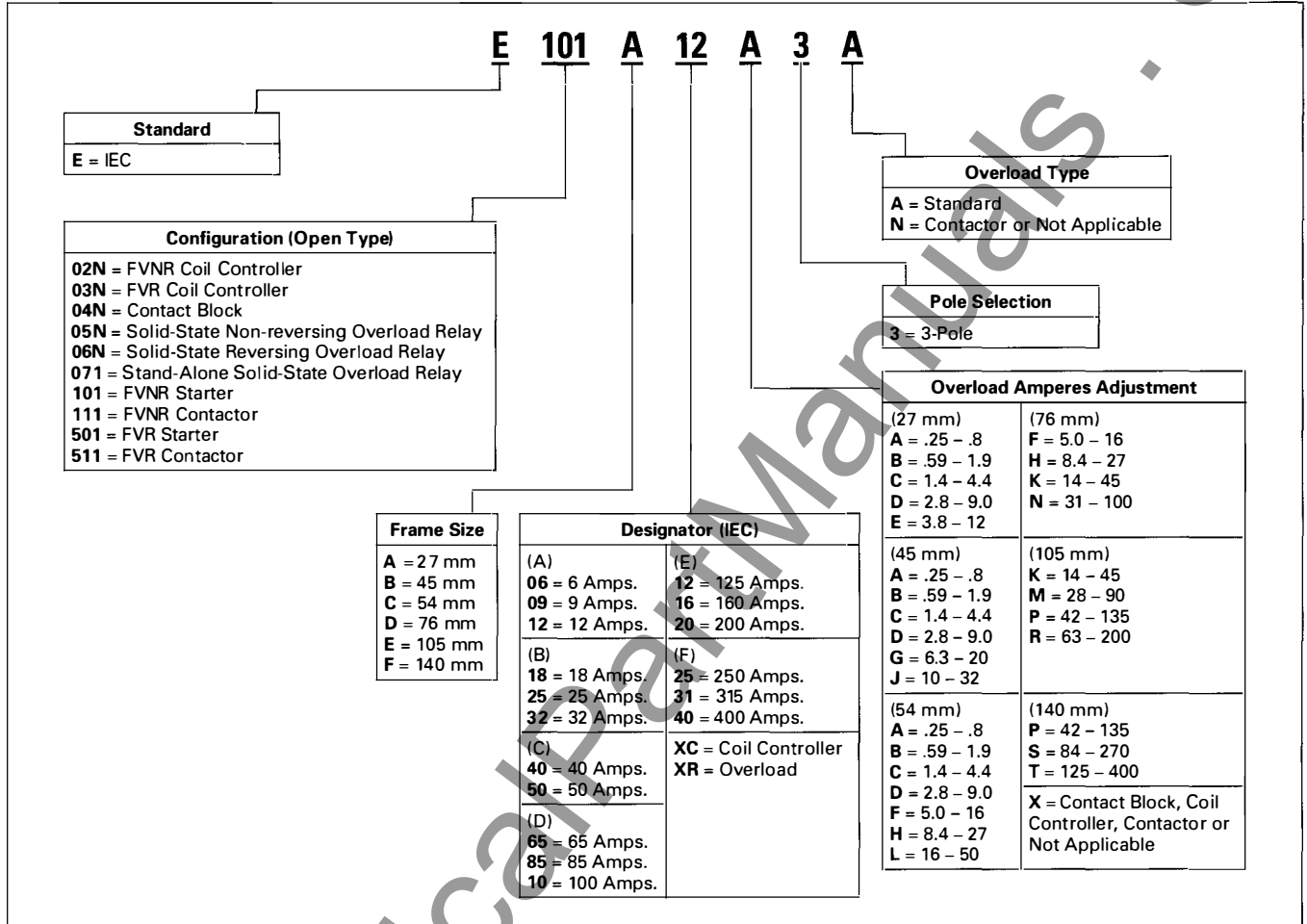

Note: When using the Catalog Numbering System for Eaton's Cutler-Hammer *IT*. Electro-Mechanical products, care should be exercised to assure that the Catalog Number for the Overload Relay aligns with the *IT*. Contact Block selected for type, frame size and ampacity, if purchased as separate components. **Example:** Select an **E05N_XR_3A** *IT*. Overload Relay for an IEC non-reversing application or an **E06N_XR_3A** for an IEC reversing application.

Examples:

- E02NCXCXNN — FVNR Coil Controller, 54 mm
- E04NB18X3N — Contact Block, 45 mm, 18 Amps
- E05NCXRL3A — Solid-State Non-reversing Overload Relay, 16 - 50 Amps
- E101B32J3A — FVNR B-Frame Starter, 32 Amps, with Solid-State Overload, 10 - 32 Amps
- E111F25X3N — FVNR F-Frame Contactor, 250 Amps
- E501D10K3A — FVR D-Frame Starter, 100 Amps, with Solid-State Overload, 14 - 45 Amps
- E511B18X3N — FVR B-Frame Contactor, 18 Amps

IT. Electro-Mechanical Line

Contents

Description	Page
Product Family Overview	
Product Description	34-2
Standards and Certifications	34-2
Instructional Leaflets	34-2
Catalog Number Selection	34-3
Contactors — Non-reversing and Reversing	
Product Description	34-4
Application Description	34-4
Features	34-4
Product Selection	34-5
Technical Data	34-12
Accessories	34-15
Auxiliary Contacts	34-17
Renewal Parts	34-19
Dimensions	34-21

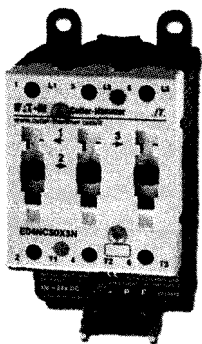

IEC Full Voltage Non-reversing Contactor, C-Frame
Cat. No. E111C50X3N

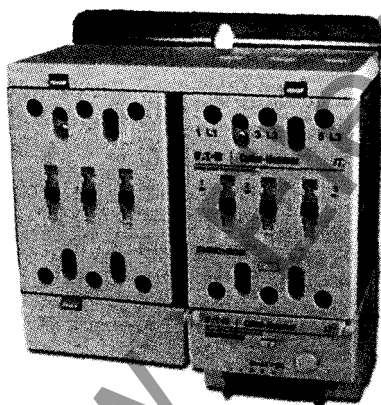

IEC Full Voltage Reversing Contactor, D-Frame
Cat. No. E511D10X3N

Product Description

The IT. Electro-Mechanical Contactor consists of an IT. Electro-Mechanical Contact Block and IT. Electro-Mechanical Coil Controller as a Full Voltage Non-reversing (FVNR) or Full Voltage Reversing (FVR) device. B-Frame (45 mm) to E-Frame (105 mm) Contact Blocks combined with Coil Controllers (factory or field assembled) are stand-alone Contactors. Only the A-Frame (27 mm) and F-Frame (140 mm) Contactors have internal factory assembled coil controllers.

Application Description

When selecting an IEC Contactor, the user must consider the specific load, utilization category and required electrical life. Actual application life may vary depending on environmental conditions and duty cycle.

Features

- 115V AC – 600V AC, 1/4 – 300 hp/ 3/4 – 250 kW, 50/60 Hz
- 24V DC Coil Control — safe, reliable global standard
- Most compact DC coil control available — e.g., A-Frame (27 mm), 7-1/2 hp @ 12A, 460V
- Frame sizes (mm): 27, 45, 54, 76, 105, 140
- No laminations, shading coils or magnet noise
- -40 to 149°F (-40 to 65°C) operating temperature
- No seal in auxiliary contacts required — control wiring is not needed between the contactor and overload relay
- Conformal coated PWM board for environmental toughness

- Front mounted auxiliary contacts
- Built-in logic to provide either 2- or 3-wire control, eliminating the need to provide and wire auxiliary contacts to seal in and interlock the contactor coils
- Easy field assembly of control wiring — plug and unplug lockable control connector
- DIN rail mounting for non-reversing A-Frame (27 mm) to D-Frame (76 mm), 6 – 100A
- Common accessories
- Long-life nickel and silver tin contacts provide excellent conductivity and superior resistance to welding and arc erosion
- Environmentally friendly materials
- IP20 Finger Protection
- Low wattage coils and minimal heat dissipation
- Auxiliary Contacts: 1NO, 1NC, 2NO, 2NC, 1NO/1NC and logic level

Reversing Contactors

- Includes Reversing Power Wiring
- Mounting Plates for B-Frame (45 mm) to E-Frame (105 mm)
- Exclusive internal electrical interlock for reversing
- Field installed Reversing Kits
- Unique coil controller/overload energizes both forward and reverse contactors — one control point for wiring

March 2002

IT Electro-Mechanical Line

Product Selection

When Ordering

Select required contactor by amp rating, frame size, kW/hp, voltage and non-reversing or reversing.

Note:

- An **E111** (45 – 105 mm) consists of an **E04N** (Contact Block) and an **E02N** (FVNR Coil Controller), factory assembled.
- An **E111** (27 and 140 mm) has an internal coil controller, factory assembled.

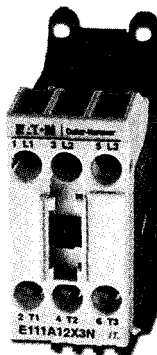

IEC A-Frame FVNR Contactor
 Cat. No. E111A12X3N

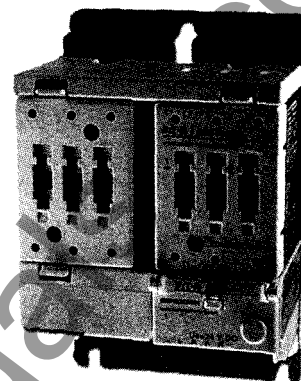

IEC B-Frame FVR Contactor
 Cat. No. E511B32X3N

34

Table 34-2. 3-Pole DC-Operated Full Voltage Non-reversing Contactors • (A – F Frames)

Max. AC-3 Amp. Rating 480V AC (Ie)	IEC 60947-4-1 AC-1 Thermal Current 480V AC and (Ith)	Frame Size ②	Maximum kW Rating @ Ue (V) 50/60 Hz						Maximum UL Horsepower (hp) 50/60 Hz						3-Pole Open Type	
			3-Phase						1-Phase		3-Phase				Catalog Number	Price U.S. \$
			220V/240V	380V	400V/415V	440V/460V	500V	550V/575V	115V/120V	220V/230V	200V/208V	230V/240V	380V/415V/460V/480V	575V/600V		
6	12	A	.75	2.2	2.2	2.2	2.2	2.2	1/4	1/2	1	1-1/2	3	3	E111A06X3N	99.
9	16	A	2.2	4	4	4	4	4	1/3	1	2	2	5	5	E111A09X3N	101.
12	20	A	3	5.5	5.5	5.5	5.5	5.5	1/2	2	3	3	7-1/2	7-1/2	E111A12X3N	130.
18	25	B	4	7.5	9	9	9	9	1	3	5	5	10	10	E111B18X3N	147.
25	40	B	5.5	12.5	12.5	12.5	12.5	12.5	2	3	5	7-1/2	15	15	E111B25X3N	164.
32	50	B	9	15	15	15	15	15	2	5	7-1/2	10	20	20	E111B32X3N	187.
40	63	C	11	18.5	18.5	22	22	22	3	7-1/2	10	10	25	25	E111C40X3N	218.
50	85	C	12.5	22	25	25	25	25	3	10	15	15	30	30	E111C50X3N	237.
65	100	D	18.5	30	33	37	37	37	5	10	20	20	50	50	E111D65X3N	348.
85	115	D	25	45	45	51	51	51	7-1/2	15	25	30	60	60	E111D85X3N	392.
100	130	D	25	51	55	59	59	59	10	20	30	30	75	75	E111D10X3N	566.
125	200	E	33	63	63	75	75	75	10	25	40	40	100	100	E111E12X3N	892.
160	225	E	45	80	80	90	90	90	15	30	50	60	125	125	E111E16X3N	1,260.
200	250	E	59	100	110	110	110	110	—	40	60	75	150	150	E111E20X3N	1,413.
250	300	F	75	—	132	150	—	150	—	50	75	100	200	200	E111F25X3N	1,913.
315	375	F	90	—	160	185	—	185	—	—	100	125	250	250	E111F31X3N	2,340.
400	450	F	110	—	220	250	—	250	—	—	125	150	300	300	E111F40X3N	3,267.

① 24V DC coil voltage.

②

Frame Size
A = 27 mm
B = 45 mm
C = 54 mm
D = 76 mm
E = 105 mm
F = 140 mm

Note:

- If required, accessories are available on **Page 34-15**.
- Consult factory for higher ampere ratings.
- Integral solid-state auxiliary hold-in circuit.
- 3 main contacts.
- F-Frame 140 mm ratings are preliminary.

Accessories Page 34-15
 Renewal Parts Page 34-19
 Technical Data Pages 34-12 – 34-14
 Dimensions Pages 34-21 – 34-24
 Discount Symbol 1CD7

17. Electro-Mechanical Line

Table 34-3. 3-Pole DC-Operated Full Voltage Reversing Contactors ① (A – F Frames)

Max. AC-3 Amp. Rating 480V AC (Ie)	IEC 60947-4-1 AC-1 Thermal Current 480V AC and (Ith)	Frame Size ②	Maximum kW Rating @ Ue (V) 50/60 Hz						Maximum UL Horsepower (hp) 50/60 Hz					3-Pole Open Type		
			3-Phase						1-Phase		3-Phase			Catalog Number	Price U.S. \$	
			220V/240V	380V	400V/415V	440V/460V	500V	550V/575V	115V/120V	220V/230V	200V/208V	230V/240V	380V/415V/460V/480V			575V/600V
6 9 12	12 16 20	A A A	.75 2.2 3	2.2 4 5.5	2.2 4 5.5	2.2 4 5.5	2.2 4 5.5	2.2 4 5.5	1/4 1/3 1/2	1/2 1 2	1 2 3	1-1/2 2 3	3 5 7-1/2	3 5 7-1/2	E511A06X3N E511A09X3N E511A12X3N	248. 252. 343.
18 25 32	25 40 50	B B B	4 5.5 9	7.5 12.5 15	9 12.5 15	9 12.5 15	9 12.5 15	9 12.5 15	1 2 2	3 3 5	5 5 7-1/2	5 7-1/2 10	10 15 20	10 15 20	E511B18X3N E511B25X3N E511B32X3N	371. 403. 447.
40 50	63 85	C C	11 12.5	18.5 22	18.5 25	22 25	22 25	22 25	3 3	7-1/2 10	10 15	10 15	25 30	25 30	E511C40X3N E511C50X3N	561. 597.
65 85 100	100 115 130	D D D	18.5 25 25	30 45 51	33 45 55	37 51 59	37 51 59	37 51 59	5 7-1/2 10	10 15 20	20 25 30	20 30 30	50 60 75	50 60 75	E511D65X3N E511D85X3N E511D10X3N	826. 1,245. 1,626.
125 160 200	200 225 250	E E E	33 45 59	63 80 100	63 80 110	75 90 110	75 90 110	75 90 110	10 15 —	25 30 40	40 50 60	40 60 75	100 125 150	100 125 150	E511E12X3N E511E16X3N E511E20X3N	2,305. 3,163. 3,674.
250 315 400	300 375 450	F F F	75 90 110	— — —	132 160 220	150 185 250	— — —	150 185 250	— — —	50 — —	75 100 125	100 125 150	200 250 300	200 250 300	E511F25X3N E511F31X3N E511F40X3N	4,943. 5,873. 8,494.

① 24V DC coil voltage.

②

Frame Size
A = 27 mm
B = 45 mm
C = 54 mm
D = 76 mm
E = 105 mm
F = 140 mm

Note:

- If required, accessories are available on **Page 34-15**.
- Consult factory for higher ampere ratings.
- Integral solid-state auxiliary hold-in circuit.
- 3 main contacts.
- F-Frame 140 mm ratings are preliminary.
- An **E511** (45 – 105 mm) consists of two **E04N** (Contact Blocks), an **E03N** (FVR Coil Controller), Mechanical Interlock, Fanning Strips and Mounting Plate, factory assembled.
- An **E511F** (140 mm) consists of two **E111F** (Contactors), an Internal Reversing Coil Controller, Mechanical Interlock and Wiring Harness, factory assembled.

Accessories	Page 34-15
Renewal Parts	Page 34-19
Technical Data	Pages 34-12 – 34-14
Dimensions	Pages 34-21 – 34-24
Discount Symbol	1CD7

Contents

<i>Description</i>	<i>Page</i>
Product Family Overview	
Product Description	34-2
Standards and Certifications	34-2
Instructional Leaflets	34-2
Catalog Number Selection	34-3
Starters — Non-reversing and Reversing	
Product Description	34-7
Features	34-7
Product Selection	34-8
Technical Data	34-12
Accessories	34-15
Auxiliary Contacts	34-17
Renewal Parts	34-19
Dimensions	34-21

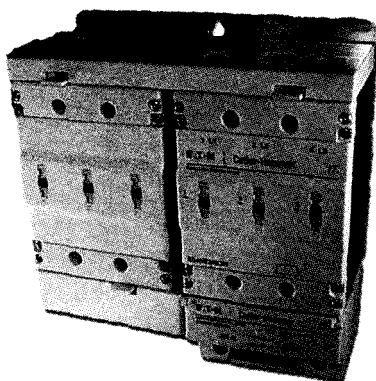

*IEC Full Voltage Reversing Starter, E Frame
Cat. No. E501E20R3A*

- Unique "Alarm without Trip" option for critical must run applications
- Lockable overload cover protects against unauthorized adjustment and reset functions
- No control wiring needed between contactor and overload relay — eliminates seal in auxiliary contacts
- Minimal heat — no full voltage coils
- -40° to 149°F (-40° to 65°C) operating temperature
- Wide 3.2:1 current adjustment range
- Exclusive internal 24-bit floating point math calculations with RMS calibrated current measurement
- Highest immunity to ESD, harmonics — minimal Total Harmonic Distortion
- IP20 Finger Protection
- Motor running thermal utilization indication
- Manual, Automatic or Remote Reset
- Easy field assembly of control wiring — plug and unplug lockable control connector
- DIN rail mountable 6A – 100A
- Communication Interface with Starter Network Adapter Product (SNAP)

Product Description

The *IT. Electro-Mechanical Starter* consists of an *IT. Electro-Mechanical Contact Block* and *IT. Electro-Mechanical Solid-State Overload Relay* as a Full Voltage Non-reversing (FVNR) or Full Voltage Reversing (FVR) device. B-Frame (45 mm) to F-Frame (140 mm) Starters are factory or field assembled.

Features

- 115V AC – 600V AC, 1/4 – 300 hp/ .75 – 250 kW, .25A – 400A Overload Amperes range, 50/60 Hz
- 24V DC control power — safe, reliable global standard
- Unique Pulse Width Modulated coil utilizes minimum energy
- Microprocessor based control
- Phase loss and current unbalance protection, user selectable
- Standard user-selectable Trip Class 10 (factory default), 20 or 30 — no individual part numbers — no programming software
- Ambient compensated
- Motor temperature and power-up protection with thermal memory
- Built-in electronic interlock for FVR units
- Easily accessible mounting feet for panel mounting
- LED status indication — trip, trip class, motor thermal state, reset, overload state

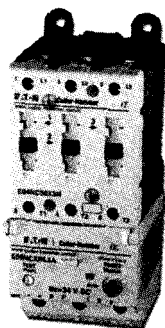

*IEC FVNR Starter, C Frame
Cat. No. E101C50L3A*

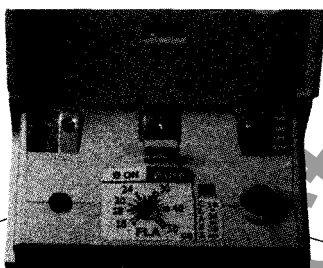

Overload Relay with Cover Open — FLA/Trip Class/Phase Protection Dial

TEST Button

RESET Button

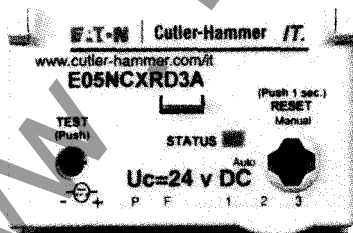

Overload Relay with Cover Closed (front view)

17. Electro-Mechanical Line

Product Selection

When Ordering

Select required Starter by kW/hp rating, voltage, phase and overload adjustment range (amperes).

Table 34-4. Full Voltage Non-reversing DC-Operated, Open Type Starters (B – D Frames), with 3-Pole Solid-State Overload Protection

Frame	Max. AC-3 Amp. Rating 480V AC (Ie)	IEC 60947-4-1 AC-1 Thermal Current 480V AC and (Ith)	Overload Adjustment Range (Amperes)	Maximum kW Rating @ Ue (V) 50/60 Hz						Maximum UL Horsepower (hp) Rating 50/60 Hz						Catalog Number	Price U.S. \$
				3-Phase						1-Phase		3-Phase					
				220V/ 240V	380V	400 V/ 415V	460V	500V	550V/ 575V	115V/ 120V	220V/ 230V	200V/ 208V	230V/ 240V	380V/ 415V/ 460V/ 480V	575V/ 600V		
B-Frame 45 mm	18	25	.25 – .8 .59 – 1.9 1.4 – 4.4 2.8 – 9.0 6.3 – 20 10 – 32	4	7.5	9	9	9	9	1	3	5	5	10	10	E101B18A3A E101B18B3A E101B18C3A E101B18D3A E101B18G3A E101B18J3A	224. 224. 224. 224. 224. 224.
	25	40	.25 – .8 .59 – 1.9 1.4 – 4.4 2.8 – 9.0 6.3 – 20 10 – 32	5.5	12.5	12.5	12.5	12.5	12.5	2	3	5	7-1/2	15	15	E101B25A3A E101B25B3A E101B25C3A E101B25D3A E101B25G3A E101B25J3A	247. 247. 247. 247. 247. 247.
	32	50	.25 – .8 .59 – 1.9 1.4 – 4.4 2.8 – 9.0 6.3 – 20 10 – 32	9	15	15	15	15	15	2	5	7-1/2	10	20	20	E101B32A3A E101B32B3A E101B32C3A E101B32D3A E101B32G3A E101B32J3A	276. 276. 276. 276. 276. 276.
C-Frame 54 mm	40	63	.25 – .8 .59 – 1.9 1.4 – 4.4 2.8 – 9.0 5.0 – 16 8.4 – 27 16 – 50	11	18.5	18.5	22	22	22	3	7-1/2	10	10	25	25	E101C40A3A E101C40B3A E101C40C3A E101C40D3A E101C40F3A E101C40H3A E101C40L3A	368. 368. 368. 368. 368. 368. 368.
	50	85	.25 – .8 .59 – 1.9 1.4 – 4.4 2.8 – 9.0 5.0 – 16 8.4 – 27 16 – 50	12.5	22	25	25	25	25	3	10	15	15	30	30	E101C50A3A E101C50B3A E101C50C3A E101C50D3A E101C50F3A E101C50H3A E101C50L3A	388. 388. 388. 388. 388. 388. 388.
D-Frame 76 mm	65	100	5.0 – 16 8.4 – 27 14 – 45 31 – 100	18.5	30	33	37	37	37	5	10	20	20	50	50	E101D65F3A E101D65H3A E101D65K3A E101D65N3A	536. 536. 536. 536.
	85	115	5.0 – 16 8.4 – 27 14 – 45 31 – 100	25	45	45	51	51	51	7-1/2	15	25	30	60	60	E101D85F3A E101D85H3A E101D85K3A E101D85N3A	615. 615. 615. 615.
	100	130	5.0 – 16 8.4 – 27 14 – 45 31 – 100	25	51	55	59	59	59	10	20	30	30	75	75	E101D10F3A E101D10H3A E101D10K3A E101D10N3A	914. 914. 914. 914.

Note:

- If required, accessories are available on **Page 34-15**.
- The standard *17* starter is for 3-phase applications. Consult factory for 1-phase applications.
- Consult factory for 27 mm A-Frame Starters, 6A – 12A.
- Class 10 (factory default), 20 and 30 Trip Times see **Figure 34-2** on **Page 34-14**.
- An **E101** (45 – 105 mm) consists of an **E04N** (Contact Block) and an **E05N** (Non-reversing Overload Relay), factory assembled. An **E101F** (140 mm) consists of an **E111** (Contactor) and an **E05N** (Non-reversing Overload Relay), factory assembled.

Accessories **Page 34-15**
 Renewal Parts **Page 34-19**
 Technical Data **Pages 34-12 – 34-14**
 Dimensions **Pages 34-25 – 34-26**
 Discount Symbol **1CD7**

Table 34-5. Full Voltage Non-reversing DC-Operated, Open Type Starters (E- F Frames) with 3-Pole Solid-State Overload Protection

Frame	Max. AC-3 Amp. Rating 480 VAC (Ie)	IEC 60947-4-1 AC-1 Thermal Current 480 VAC and (Ith)	Overload Adjustment Range (Amperes)	Maximum kW Rating @ Ue (V) 50/60 Hz						Maximum UL Horsepower (hp) Rating 50/60 Hz						Catalog Number	Price U.S. \$
				3-Phase						1-Phase		3-Phase					
				220V/240V	380V	400V/415V	460V	500V	550V/575V	115V/120V	220V/230V	200V/208V	230V/240V	380V/415V/460V/480V	575V/600V		
E-Frame 105 mm	125	200	14 - 45 28 - 90 42 - 135 63 - 200	33	63	63	75	75	75	10	25	40	40	100	100	E101E12K3A E101E12M3A E101E12P3A E101E12R3A	1,286. 1,286. 1,286. 1,286.
	160	225	14 - 45 28 - 90 42 - 135 63 - 200	45	80	80	90	90	90	15	30	50	60	125	125	E101E16K3A E101E16M3A E101E16P3A E101E16R3A	1,659. 1,659. 1,659. 1,659.
	200	250	14 - 45 28 - 90 42 - 135 63 - 200	59	100	110	110	110	110	—	40	60	75	150	150	E101E20K3A E101E20M3A E101E20P3A E101E20R3A	1,754. 1,754. 1,754. 1,754.
F-Frame 140 mm	250	300	42 - 135 84 - 270 125 - 400	75	—	132	150	—	150	—	50	75	100	200	200	E101F25P3A E101F25S3A E101F25T3A	2,451. 2,451. 2,451.
	315	375	42 - 135 84 - 270 125 - 400	90	—	160	185	—	185	—	—	100	125	250	250	E101F31P3A E101F31S3A E101F31T3A	3,475. 3,475. 3,475.
	400	450	42 - 135 84 - 270 125 - 400	110	—	120	250	—	250	—	—	125	150	300	300	E101F40P3A E101F40S3A E101F40T3A	4,400. 4,400. 4,400.

Note:

- If required, accessories are available on Page 34-15.
- Consult factory for higher ampere ratings.
- Class 10, 20 and 30 Trip Times see Figure 34-2 on Page 34-14.
- F-Frame 140 mm ratings are preliminary.
- An E101 (45 - 105 mm) consists of an E04N (Contact Block) and an E05N (Non-reversing Overload Relay) factory assembled. An E101F (140 mm) consists of an E111 (Contactor) and an E05N (Non-reversing Overload Relay), factory assembled.
- The standard IT. starter is for 3-phase applications. Consult factory for 1-phase applications.

Accessories Page 34-15
 Renewal Parts Page 34-19
 Technical Data Pages 34-12 - 34-14
 Dimensions Pages 34-25 - 34-26
 Discount Symbol 1CD7

17. Electro-Mechanical Line

Table 34-6. Full Voltage Reversing DC-Operated, Open Type Starters (B – D Frames) with 3-Pole Solid-State Overload Protection ①

Frame	Max. AC-3 Amp. Rating 480V AC (Ie)	IEC 60947-4-1 AC-1 Thermal Current 480V AC and (Ith)	Overload Adjustment Range (Amperes)	Maximum kW Rating @ Ue (V) 50/60 Hz						Maximum UL Horsepower (hp) Rating 50/60 Hz						Catalog Number	Price U.S. \$
				3-Phase						1-Phase		3-Phase					
				220V/ 240V	380V	400V/ 415V	440V/ 460V	500V	550V/ 575V	115V/ 120V	220V/ 230V	200V/ 208V	230V/ 240V	380V/ 415V/ 460V/ 480V	575V/ 600V		
B-Frame 45 mm	18	25	.25 – .8 .59 – 1.9 1.4 – 4.4 2.8 – 9.0 6.3 – 20 10 – 32	4	7.5	9	9	9	9	1	3	5	5	10	10	E501B18A3A E501B18B3A E501B18C3A E501B18D3A E501B18G3A E501B18J3A	474. 474. 474. 474. 474. 474.
	25	40	.25 – .8 .59 – 1.9 1.4 – 4.4 2.8 – 9.0 6.3 – 20 10 – 32	5.5	12.5	12.5	12.5	12.5	12.5	2	3	5	7-1/2	15	15	E501B25A3A E501B25B3A E501B25C3A E501B25D3A E501B25G3A E501B25J3A	541. 541. 541. 541. 541. 541.
	32	50	.25 – .8 .59 – 1.9 1.4 – 4.4 2.8 – 9.0 6.3 – 20 10 – 32	9	15	15	15	15	15	2	5	7-1/2	10	20	20	E501B32A3A E501B32B3A E501B32C3A E501B32D3A E501B32G3A E501B32J3A	609. 609. 609. 609. 609. 609.
C-Frame 54 mm	40	63	.25 – .8 .59 – 1.9 1.4 – 4.4 2.8 – 9.0 5.0 – 16 8.4 – 27 16 – 50	11	18.5	18.5	22	22	22	3	7-1/2	10	10	25	25	E501C40A3A E501C40B3A E501C40C3A E501C40D3A E501C40F3A E501C40H3A E501C40L3A	762. 762. 762. 762. 762. 762. 762.
	50	85	.25 – .8 .59 – 1.9 1.4 – 4.4 2.8 – 9.0 5.0 – 16 8.4 – 27 16 – 50	12.5	22	25	25	25	25	3	10	15	15	30	30	E501C50A3A E501C50B3A E501C50C3A E501C50D3A E501C50F3A E501C50H3A E501C50L3A	856. 856. 856. 856. 856. 856. 856.
D-Frame 76 mm	65	100	5.0 – 16 8.4 – 27 14 – 45 31 – 100	18.5	30	33	37	37	37	5	10	20	20	50	50	E501D65F3A E501D65H3A E501D65K3A E501D65N3A	1,161. 1,161. 1,161. 1,161.
	85	115	5.0 – 16 8.4 – 27 14 – 45 31 – 100	25	45	45	51	51	51	7-1/2	15	25	30	60	60	E501D85F3A E501D85H3A E501D85K3A E501D85N3A	1,460. 1,460. 1,460. 1,460.
	100	130	5.0 – 16 8.4 – 27 14 – 45 31 – 100	25	51	55	59	59	59	10	20	30	30	75	75	E501D10F3A E501D10H3A E501D10K3A E501D10N3A	2,038. 2,038. 2,038. 2,038.

① 24V DC coil voltage.

Note:

- If required, accessories are available on **Page 34-15**.
- The standard *17* starter is for 3-phase applications only.
- An **E501** (45 – 105 mm) consists of two **E04N** (Contact Blocks), an **E06N** (Reversing Overload Relay), Fanning Strips, Mechanical Interlock and Mounting Plate. An **E501F** (140 mm) consists of two **E111F** (Contactors), an **E06NF** (Reversing Overload Relay), Mechanical Interlock and Reversing Wiring Harness.
- Consult Factory for 27 mm A-Frame Reversing Starters, 6A – 12A.

Accessories	Page 34-15
Renewal Parts	Page 34-19
Technical Data	Pages 34-12 – 34-14
Dimensions	Pages 34-25 – 34-26
Discount Symbol	1CD7

Table 34-7. Full Voltage Reversing DC-Operated, Open Type Starters (E – F Frames) with 3-Pole Solid-State Overload Protection ①

Frame	Max. AC-3 Amp. Rating 480V AC (Ie)	IEC 60947-4-1 AC-1 Thermal Current 480V AC and (Ith)	Overload Adjustment Range (Amperes)	Maximum kW Rating @ Ue (V) 50/60 Hz						Maximum UL Horsepower (hp) Rating 50/60 Hz						Catalog Number	Price U.S. \$
				3-Phase Continuous						1-Phase		3-Phase					
				220V/ 240V	380V	400V/ 415V	460V	500V	550V/ 575V	115V/ 120V	220V/ 230V	200V/ 208V	230V/ 240V	380V/ 415V/ 460V/ 480V	575V/ 600V		
E-Frame 105 mm	125	200	14 – 45 28 – 90 42 – 135 63 – 200	33	63	63	75	75	75	10	25	40	40	100	100	E501E12K3A E501E12M3A E501E12P3A E501E12R3A	2,731. 2,731. 2,731. 2,731.
	160	225	14 – 45 28 – 90 42 – 135 63 – 200	45	80	80	90	90	90	15	30	50	60	125	125	E501E16K3A E501E16M3A E501E16P3A E501E16R3A	3,686. 3,686. 3,686. 3,686.
	200	250	14 – 45 28 – 90 42 – 135 63 – 200	59	100	110	110	110	110	—	40	60	75	150	150	E501E20K3A E501E20M3A E501E20P3A E501E20R3A	3,897. 3,897. 3,897. 3,897.
F-Frame 140 mm	250	300	42 – 135 84 – 270 125 – 400	75	—	132	150	—	150	—	50	75	100	200	200	E501F25P3A E501F25S3A E501F25T3A	5,203. 5,203. 5,203.
	315	375	42 – 135 84 – 270 125 – 400	90	—	160	185	—	185	—	—	100	125	250	250	E501F31P3A E501F31S3A E501F31T3A	7,718. 7,718. 7,718.
	400	450	42 – 135 84 – 270 125 – 400	110	—	220	250	—	250	—	—	125	150	300	300	E501F40P3A E501F40S3A E501F50T3A	9,772. 9,772. 9,772.

① 24V DC coil voltage.

Note:

- If required, accessories are available on **Page 34-15**.
- The standard *IT* starter is for 3-phase applications only.
- An **E501** (45 – 105 mm) consists of two **E04N** (Contact Blocks), an **E06N** (Reversing Overload Relay), Fanning Strips, Mechanical Interlock and Mounting Plate. An **E501F** (140 mm) consists of two **E111F** (Contactors), an **E06NF** (Reversing Overload Relay), Mechanical Interlock and Reversing Wiring Harness.
- Consult Factory for 27 mm A-Frame Reversing Starters, 6A – 12A.

34

Accessories	Page 34-15
Renewal Parts	Page 34-19
Technical Data	Pages 34-12 – 34-14
Dimensions	Pages 34-25 – 34-26
Discount Symbol	1CD7

IT. Electro-Mechanical Line

Table 34-8. Specifications

Description	A-Frame 27 mm ^②	B-Frame 45 mm	C-Frame 54 mm	D-Frame 76 mm	E-Frame 105 mm	F-Frame 140 mm
Overall Dimensions in Inches (mm) ^① — w x h x d						
Non-reversing Contactor	1.1 x 3.0 x 2.4 (27 x 75 x 60)	1.8 x 4.4 x 2.4 (45 x 111 x 60)	2.1 x 4.5 x 2.4 (54 x 113 x 60)	3.0 x 5.9 x 3.1 (76 x 150 x 79)	4.1 x 8.0 x 3.5 (105 x 203 x 90)	5.5 x 13.9 x 7.0 (140 x 354 x 178)
Reversing Contactor	2.4 x 2.9 x 2.4 (60 x 73 x 60)	3.8 x 5.9 x 2.7 (96 x 149 x 69)	4.5 x 5.9 x 2.6 (114 x 149 x 67)	6.2 x 7.4 x 3.3 (158 x 188 x 84)	8.5 x 9.5 x 3.8 (216 x 242 x 97)	11.7 x 13.9 x 7.2 (296 x 354 x 183)
Non-reversing Starter	—	1.8 x 4.4 x 2.4 (45 x 111 x 60)	2.1 x 4.5 x 2.4 (54 x 113 x 60)	3.0 x 5.9 x 3.1 (76 x 150 x 79)	4.1 x 8.0 x 3.5 (105 x 203 x 90)	5.7 x 19.4 x 7.0 (145 x 492 x 178)
Reversing Starter	—	3.8 x 5.9 x 2.7 (96 x 149 x 69)	4.5 x 5.9 x 2.6 (114 x 149 x 67)	6.2 x 7.4 x 3.3 (158 x 188 x 84)	8.5 x 9.5 x 3.8 (216 x 242 x 97)	11.8 x 19.4 x 7.2 (300 x 492 x 183)
Weights in Lb. (kg)						
Non-reversing Contactor	.3 (.14)	.7 (.31)	.9 (.42)	2.8 (1.27)	6.7 (3.05)	20.0 (9.1)
Reversing Contactor	.6 (.27)	1.9 (.86)	2.6 (1.17)	6.9 (3.13)	16.9 (7.67)	48.0 (21.8)
Non-reversing Starter	—	.9 (.40)	1.2 (.53)	2.9 (1.32)	7.1 (3.20)	27.0 (12.3)
Reversing Starter	—	2.0 (.90)	2.6 (1.20)	7.1 (3.20)	16.8 (7.60)	55.0 (25.0)
Mounting Hole Spacing in Inches (mm) — w x h						
Non-reversing Contactor	.76 x 2.64 (19.2 x 67)	1.33 x 4 (33.8 x 101)	1.46 x 4.10 (37 x 104)	.95 x 2.88 (24 x 73)	1.33 x 4.14 (33.8 x 105)	Consult factory
Reversing Contactor	1.30 x 2.52 (33 x 64)	3.15 x 5.36 (80 x 136)	3.15 x 5.36 (80 x 136)	5.51 x 6.89 (140 x 175)	7.88 x 9.06 (200 x 230)	
Non-reversing Starter	—	1.33 x 4.62 (33.8 x 117.3)	1.46 x 5.04 (37 x 128)	.95 x 2.88 (24 x 73)	1.33 x 4.14 (33.8 x 105)	
Reversing Starter	—	3.15 x 5.36 (80 x 136)	3.15 x 5.36 (80 x 136)	5.51 x 6.89 (140 x 175)	7.88 x 9.06 (200 x 230)	
Mounting Positions						
Panel-Vertical	Yes	Yes	Yes	Yes	Yes	Yes
Panel-Horizontal	Yes	Yes	Yes	Yes	Yes	Yes
DIN Rail Mountable	Yes	Yes ^③	Yes ^③	Yes ^③	No	No
Temperature						
Operating	-40° to +149°F (-40° to +65°C)	-40° to +149°F (-40° to +65°C)	-40° to +149°F (-40° to +65°C)	-40° to +149°F (-40° to +65°C)	-40° to +149°F (-40° to +65°C)	-40° to +149°F (-40° to +65°C)
Storage	-58° to +176°F (-50° to +80°C)	-58° to +176°F (-50° to +80°C)	-58° to +176°F (-50° to +80°C)	-58° to +176°F (-50° to +80°C)	-58° to +176°F (-50° to +80°C)	-58° to +176°F (-50° to +80°C)
Insulation Voltage (Ui)						
	690V	690V	690V	690V	690V	690V
Impulse Withstand Voltage (Uimp)						
	6 kV	6 kV	6 kV	6 kV	6 kV	6 kV
Mechanical Life						
	20,000,000	10,000,000	10,000,000	8,000,000	8,000,000	5,000,000
Electrical Life ^{●●}						
AC-2, AC-3 (@ max. amps.)	1,000,000 – 4,000,000	1,000,000 – 3,000,000	1,000,000 – 2,000,000	800,000 – 2,000,000	800,000 – 1,500,000	500,000 – 1,000,000
AC-4 (@ max. amps.)	—	—	—	—	—	—
Current Ratings @ 480V Maximum						
AC-1 Thermal Current I _{th}	20	50	85	130	250	450
AC-2, AC-3 Operating Current (I _e)	12	32	50	100	200	400
AC-4 Operating Current (I _e)	10	32	50	100	150	280
Operation Performance						
Coil Voltage (nominal)	24V DC	24V DC	24V DC	24V DC	24V DC	24V DC
Coil Operating Voltage Range (V DC)	20 – 28	20 – 28	20 – 28	20 – 28	20 – 28	20 – 28
Coil Insulation Rating	130°C	180°C	180°C	180°C	180°C	180°C
Pull-In Time (ms) ^⑤	—	14	14	24	31	—
Drop-Out Time (ms) ^⑤	—	5	5	11	16	—
Mechanical Operating Rate						
	6/sec	3/sec	3/sec	2/sec	2/sec	1/sec

^① Auxiliaries add .91" (23 mm) to depth for single, .50" (30 mm) for dual.

^② Contactors only.

^③ Non-reversing contactors and starters only.

^{●●} See Figure 34-1, Life-Load Curves, for maximum operations per frame size at various amperes.

^⑤ Excluding debounce time of 50 ms.

^⑥ Preliminary data.

March 2002

IT. Electro-Mechanical Line

Table 34-8. Specifications, continued

Description	A-Frame 27 mm	B-Frame 45 mm	C-Frame 54 mm	D-Frame 76 mm	E-Frame 105 mm	F-Frame 140 mm
AWG Wire Range (Stranded or Solid)						
Power Terminals	16 – 12 AWG (1.5 – 2.5 mm ²)	14 – 8 AWG (1.5 – 10 mm ²)	14 – 4 AWG (1.5 – 16 mm ²)	14 – 1 AWG (1.5 – 35 mm ²)	6 – 250MCM (16 – 120 mm ²)	4 – 600MCM (16 – 300 mm ²)
2 Conductors per terminal	(2) 16 – 12 AWG (1.5 – 2.5 mm ²)	(2) 14 – 10 AWG (1.5 – 4.0 mm ²)	(2) 14 – 6 AWG (1.5 – 16 mm ²)	(2) 14 – 2 AWG (1.5 – 25 mm ²)	(2) 6 – 3/0 AWG (16 – 70 mm ²)	(2) 4 – 250MCM (16 – 120 mm ²)
Strip Length	.32" (8 mm)	.45" (11 mm)	.5" (12 mm)	.7" (18 mm)	.8" (21 mm)	1.5" (40 mm)
Torque (max.)	18 lb-in (2.0 Nm)	20 lb-in (2.2 Nm) for 14 – 10 AWG (1.5 – 6 mm ²); 25 lb-in (2.8 Nm) for 8 AWG (10 mm ²)	35 lb-in (4.0 Nm) for 14 – 10 AWG (1.5 – 6 mm ²); 40 lb-in (4.5 Nm) for 8 AWG (10 mm ²); 45 lb-in (5.0 Nm) for 6 – 4 AWG (16 mm ²)	45 lb-in (5.0 Nm) for Single 14 – 8 AWG (1.5 – 1.0 mm ²); 10 lb-in (11 Nm) for Single 6 – 1 AWG (16 – 35 mm ²) and Dual Wire Combinations	250 lb-in (28 Nm)	550 lb-in (62 Nm)
Driver	PZ1 or 3/16" Flat	2.5 mm Hex Key	3 mm Hex Key	5/32" (4 mm) Hex Key	5/16" (8 mm) Hex Key	5/16" (8 mm) Hex Key
Control Terminals	22 – 12 AWG (.5 – 2.5 mm ²)	22 – 12 AWG (.5 – 2.5 mm ²)	22 – 12 AWG (.5 – 2.5 mm ²)	22 – 12 AWG (.5 – 2.5 mm ²)	22 – 12 AWG (.5 – 2.5 mm ²)	22 – 12 AWG (.5 – 2.5 mm ²)
Control Terminals (+ and -)	14 – 12 AWG (1.5 – 2.5 mm ²)	14 – 12 AWG (1.5 – 2.5 mm ²)	14 – 12 AWG (1.5 – 2.5 mm ²)	14 – 12 AWG (1.5 – 2.5 mm ²)	14 – 12 AWG (1.5 – 2.5 mm ²)	14 – 12 AWG (1.5 – 2.5 mm ²)
Conductors per terminal	1	1	1	1	1	1
Torque lb-in (Nm)	4.5 lb-in (0.5 Nm)	4.5 lb-in (0.5 Nm)	4.5 lb-in (0.5 Nm)	4.5 lb-in (0.5 Nm)	4.5 lb-in (0.5 Nm)	4.5 lb-in (0.5 Nm)
Strip Length	.25" (7 mm)	.25" (7 mm)	.25" (7 mm)	.25" (7 mm)	.25" (7 mm)	.25" (7 mm)
Finger Protection						
Front	IP20	IP20	IP20	IP20	IP20	IP20
At Terminals	IP20	IP10	IP10	IP00	IP00	IP00
At Terminals with max. size wire installed	IP20	IP20	IP10	IP10	IP00	IP00
Environmental						
Shock	15G	15G	15G	15G	15G	15G
Vibration	5G	5G	5G	5G	5G	5G
Pollution Degree	2	2	2	2	2	2
EMC Environment	1	1	1	1	1	1
Altitude ①	2000 Meters	2000 Meters	2000 Meters	2000 Meters	2000 Meters	2000 Meters

① Above 2000 meters, consult factory.

Table 34-9. 24V DC Power Supply Requirements @ 68°F (20°C) (see Note below)

Contactor/Starter Size Catalog Number ②	Sealed In		Inrush		Duration (msecs)		
	Frame	mm	Wattage	Amps		Wattage	Amps
E_11A_X3N	A	27	1.3	.054	20	.83	30
E_11B_X3N	B	45	3.7	.15	80	3.3	50
E_01B__3A	B	45	3.2	.13	80	3.3	50
E_11C_X3N	C	54	4.2	.18	90	3.8	50
E_01C__3A	C	54	3.6	.15	90	3.8	50
E_1D__3_	D	76	5.0	.21	130	5.4	65
E_1E__3_	E	105	5.6	.23	140	5.8	85
E_1F__3_	F	140	③	③	③	③	③

② _ indicates missing digit/character of the Catalog Number; may have multiple values.

③ Consult factory.

Note: At other temperatures expressed in °C, for either inrush or sealed, use the 20°C value from the table in the following:

$$\text{Watts} = W_{20} [1.1 - .005(T)] \text{ and Amps} = A_{20} [1.1 - .005(T)]$$

For example, inrush requirements for a D Frame Starter at -25°C would be:

$$\text{Watts} = 130 [1.1 - .005(-25)] = 160$$

$$\text{Amps} = 5.4 [1.1 - .005(-25)] = 6.6$$

IT Electro-Mechanical Line

Electrical Life — AC-1, AC-2, AC-3 and AC-4 Utilization Categories

Table 34-10. Utilization Categories

The International Electrotechnical Commission (IEC) has developed utilization categories for contactors and auxiliary contacts. The categories describe the type of electrical load and the conditions for making and breaking the current.

Category	Typical Application
AC-1	Non-inductive or slightly inductive loads: Resistance furnaces, heating.
AC-2	Slip-ring motors: Starting and stopping of running motors
AC-3	Squirrel cage motors: Starting, switching off motors during running (motors in most industrial applications typically fall into this category).
AC-4	Squirrel cage motors: Starting, plugging ①, inching ② (very few applications in industry are totally AC-4).

- ① Plugging is stopping or reversing the motor rapidly by reversing the connections while the motor is running.
- ② Inching or jogging is energizing the motor once or repeatedly for short durations to obtain small movements of the motor driven load.

Life Load Curves — Cutler-Hammer's IT Electro-Mechanical Series IEC contactors have been designed and manufactured for superior life performance. All testing has been based on requirements as found in IEC 60947-4-1 and conducted by Cutler-Hammer. When selecting a contactor designed to IEC requirements, the specifier must give attention to the specific load, utilization category and the required electrical life. For a definition of Utilization Categories, see Table 34-10 above.

Note: AC-3 tests are conducted at rated device currents and AC-4 tests are conducted at six-times rated device currents. All tests have been run at 600V, 60 Hz.

Actual application life may vary, depending on environmental conditions and application duty cycle.

Contactor Choice —

- Decide what utilization category the application is and choose the appropriate curve from Figure 34-1.
- Locate the intersection of the life-load curve of the appropriate contactor with the operational current (I_e) of the application, as found on the horizontal axis.
- Read the estimated contact life along the vertical axis in number of operational cycles.

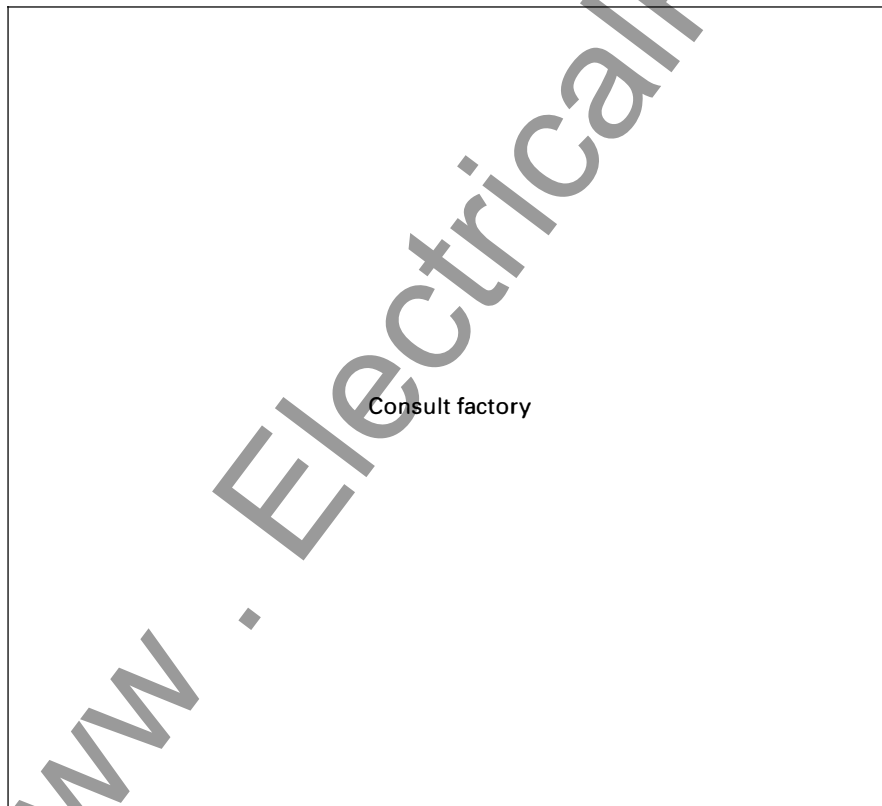

Figure 34-1. Electrical Life — AC-3 and AC-4 Utilization Categories

Trip Times

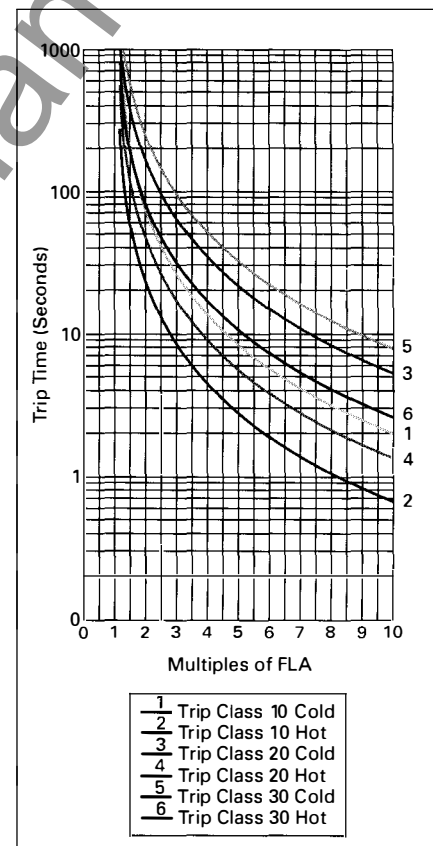
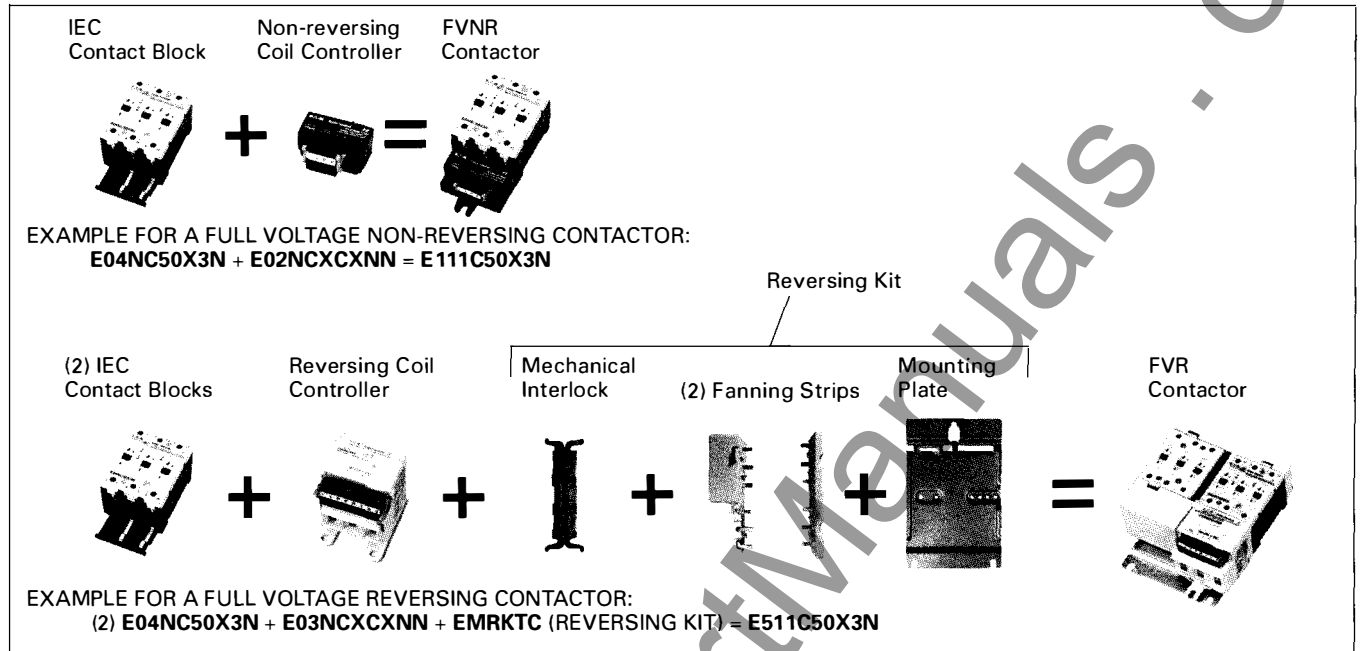

Figure 34-2. Class 10, 20 and 30 Trip Curves

March 2002

17. Electro-Mechanical Line

Modular Components — Contactor Field Assembly



34

Figure 34-3. Modular Contactor Assembly

Modular Components — Starter Field Assembly

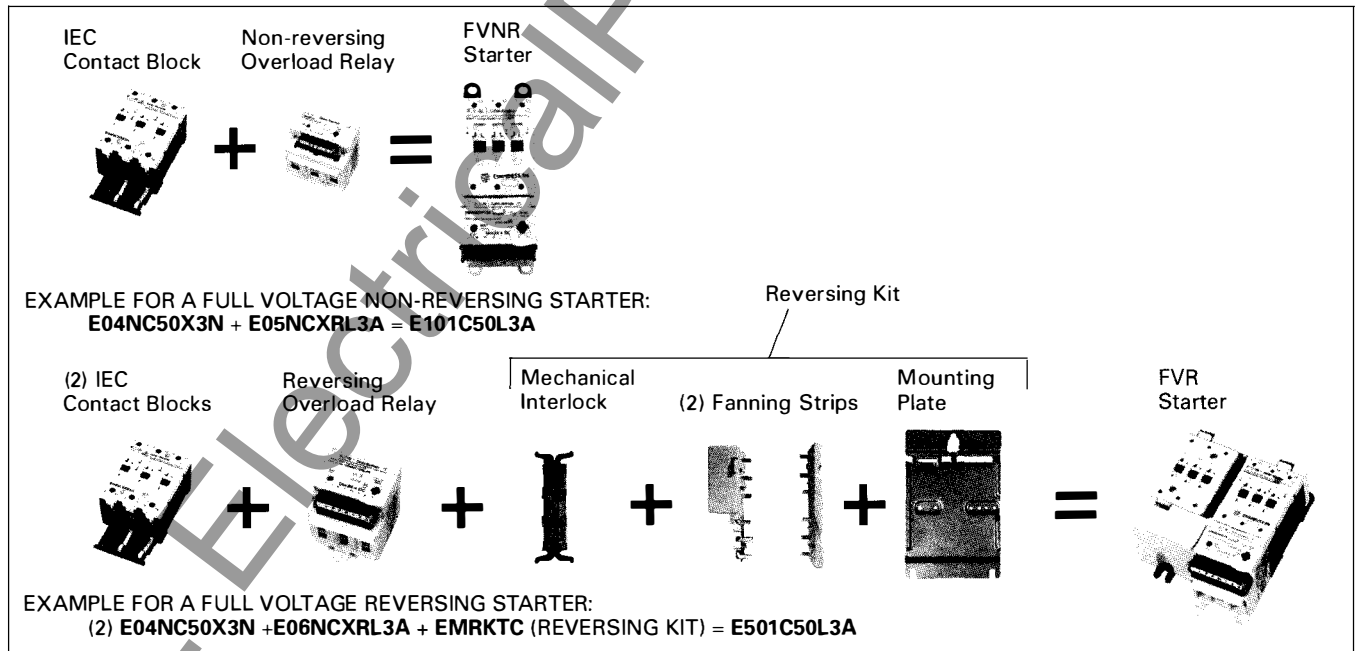
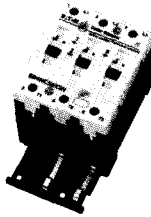

Figure 34-4. Modular Starter Assembly

17. Electro-Mechanical Line

IEC Contact Block



34

Table 34-11. IEC Contact Block

Frame	Amperes	Catalog Number	Price U.S. \$
B-Frame 45 mm	18	E04NB18X3N	—
	25	E04NB25X3N	—
	32	E04NB32X3N	—
C-Frame 54 mm	40	E04NC40X3N	—
	50	E04NC50X3N	—
D-Frame 76 mm	65	E04ND65X3N	—
	85	E04ND85X3N	—
	100	E04ND10X3N	—
E-Frame 105 mm	125	E04NE12X3N	—
	160	E04NE16X3N	—
	200	E04NE20X3N	—

Note:

- E04N + E05N = E101; E04N + E02N = E111 (45 - 105 mm)
- E04N + E06N = E501; E04N + E03N = E511 (45 - 105 mm)

IEC Solid-State Overload Relay — Non-reversing

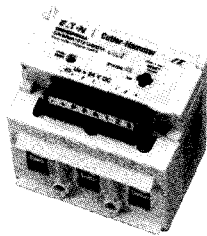

Table 34-12. IEC Solid-State Overload Relay — Non-reversing

Frame	Overload Adjustment Range (Amperes)	Catalog Number	Price U.S. \$
B-Frame 45 mm	.25 - .8	E05NBXRA3A	—
	.59 - 1.9	E05NBXRB3A	—
	1.4 - 4.4	E05NBXRC3A	—
	2.8 - 9.0	E05NBXRD3A	—
	6.3 - 20	E05NBXRG3A	—
	10 - 32	E05NBXRJ3A	—
C-Frame 54 mm	.25 - .8	E05NCXRA3A	—
	.59 - 1.9	E05NCXRB3A	—
	1.4 - 4.4	E05NCXRC3A	—
	2.8 - 9.0	E05NCXRD3A	—
	5.0 - 16	E05NCXRF3A	—
	8.4 - 27	E05NCXRH3A	—
D-Frame 76 mm	16 - 50	E05NCXRL3A	—
	5.0 - 16	E05NDXRF3A	—
	8.4 - 27	E05NDXRH3A	—
E-Frame 105 mm	14 - 45	E05NDXRK3A	—
	28 - 90	E05NDXRN3A	—
	31 - 100	E05NEXRK3A	—
F-Frame 140 mm	42 - 135	E05NEXRM3A	—
	84 - 270	E05NEXRP3A	—
	125 - 400	E05NEXRR3A	—

IEC Coil Controller

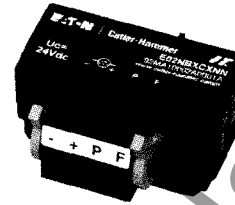

Table 34-13. IEC Coil Controller — Non-reversing

Frame	Catalog Number	Price U.S. \$
Non-reversing		
B — 45 mm	E02NBXCXNN	—
C — 54 mm	E02NCXCXNN	—
D — 76 mm	E02NDXCXNN	—
E — 105 mm	E02NEXCXNN	—
Reversing		
B — 45 mm	E03NBXCXNN	—
C — 54 mm	E03NCXCXNN	—
D — 76 mm	E03NDXCXNN	—
E — 105 mm	E03NEXCXNN	—
Universal Coil Controller (Non-rev./Rev.)		
F — 140 mm	EMUCCF	—

IEC Solid State Overload Relay — Reversing

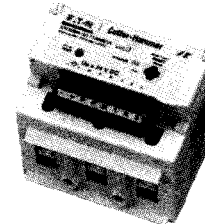
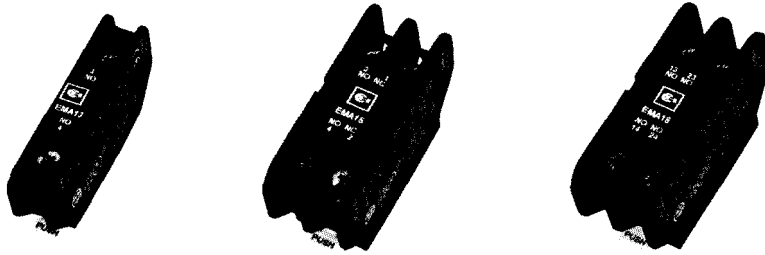

Table 34-14. IEC Overload Relay — Reversing

Frame	Overload Adjustment Range (Amperes)	Catalog Number	Price U.S. \$
B-Frame 45 mm	.25 - .8	E06NBXRA3A	—
	.59 - 1.9	E06NBXRB3A	—
	1.4 - 4.4	E06NBXRC3A	—
	2.8 - 9.0	E06NBXRD3A	—
	6.3 - 20	E06NBXRG3A	—
	10 - 32	E06NBXRJ3A	—
C-Frame 54 mm	.25 - .8	E06NCXRA3A	—
	.59 - 1.9	E06NCXRB3A	—
	1.4 - 4.4	E06NCXRC3A	—
	2.8 - 9.0	E06NCXRD3A	—
	5.0 - 16	E06NCXRF3A	—
	8.4 - 27	E06NCXRH3A	—
D-Frame 76 mm	16 - 50	E06NCXRL3A	—
	5.0 - 16	E06NDXRF3A	—
	8.4 - 27	E06NDXRH3A	—
E-Frame 105 mm	14 - 45	E06NDXRK3A	—
	28 - 90	E06NDXRN3A	—
	31 - 100	E06NEXRK3A	—
F-Frame 140 mm	42 - 135	E06NEXRM3A	—
	84 - 270	E06NEXRP3A	—
	125 - 400	E06NEXRR3A	—

Discount Symbol 1CD1

Auxiliary Contacts



Auxiliary Contacts are available for mounting on 17. Electro-Mechanical Contactors and Starters. The various choices available for non-reversing models are shown in Tables 34-15 and 34-16, and their ratings in Tables 34-17 – 34-19. For reversing models, the number of auxiliaries indicated is for each of the contactors/ starters in the assembly.

Table 34-15. Auxiliary Contact Availability — A – E Frames

Front Mounted (Maximum Circuits per Contactor/Starter)					Contact Type	Catalog Number	Price U.S. \$
Contactor/Starter Size							
A-Frame 27 mm	B-Frame 45 mm ●	C-Frame 54 mm ①	D-Frame 76 mm	E-Frame 105 mm			
1	3	3	3	3	1NO	EMA13	20.90
1	3	3	3	3	1NC	EMA14	20.90
—	2	2	3	3	1NO-1NC	EMA15	28.00
—	2	2	3	3	2NO	EMA16	28.00
—	2	2	3	3	2NC	EMA17	28.00
1	2	3	3	3	Logic Level 1NO-1NC	EMA70	33.00

① One EMA70 contact may be used in the center position in conjunction with two EMA15, EMA 16 or EMA 17 contacts in the center positions.

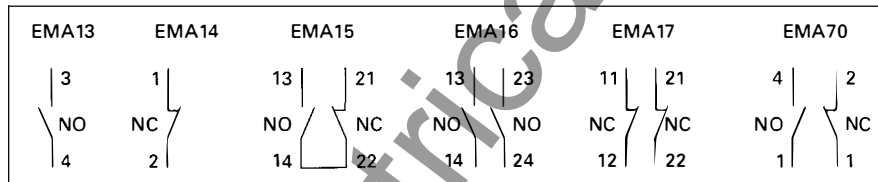

Figure 34-5. Connecting Diagram — A – E Frames

Table 34-16. Auxiliary Contact — F-Frame

Front or Side Mounted ② — Maximum (14) Total Circuits				
F-Frame 140 mm	Contact Type	Description	Catalog Number	Price U.S. \$
1	1NO	Base auxiliary (max. 1 per side)	EMASB13	43.00
1	1NO-1NC	Base auxiliary (max. 1 per side)	EMASB15	43.00
2	1NO	Base auxiliary (max. 2 Add-on auxiliary per side) EMASB13 or EMASB15 required	EMASA13	43.00
2	1NC	Base auxiliary (max. 2 Add-on auxiliary per side) EMASB13 or EMASB15 required	EMASA14	58.00
1	1NO-1NC	Base auxiliary (max. 1 Add-on auxiliary per side) EMASB13 or EMASB15 required	EMASA15	58.00
3	1NO-1NC	Front mounted (max. 3)	EMA70	33.00

② Maximum (3) auxiliaries per side.

Table 34-17. IEC Ratings

DC-13		AC-15	
U _e Voltage	I _e Amps.	U _e Voltage	I _e Amps.
24	5	48	8
48	2.5	120	6
125	1.1	240	4
250	.55	440	2

Table 34-18. A600 Ratings

Current	AC Voltage			
	120	240	480	600
Make and Interrupting	60	30	15	12
Break	6	3	1.5	1.2
Continuous	10	10	10	10
Thermal	10	10	10	10

Table 34-19. P300 Ratings

Current	DC Voltage	
	125	250
Make and Interrupting	1.1	.55
Break	1.1	.55
Continuous	5	5
Thermal	5	5

Table 34-20. EMA70 Auxiliary Contact

U _e Voltage	I _t Amps
125 – 250	.1

IT. Electro-Mechanical Line

Mounting Plates and DIN Rails

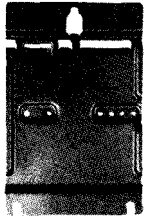

34

Table 34-21. Mounting Plates/DIN Rails

Frame Size	Metal Reversing Contactor/Starter Plates		Metal Combo Device Plate Non-reversing		Stand-Alone Solid-State Overload Panel/DIN	
	Catalog Number	Price U.S. \$	Catalog Number	Price U.S. \$	Catalog Number	Price U.S. \$
A	—	—	EMA10A	—	EMA11A	—
B	EMA9B	—	EMA10B	—	EMA11B	—
C	EMA9B	—	EMA10C	—	EMA11C	—
D	EMA9D	—	EMA10D	—	EMA11D	—
E	EMA9E	—	EMA10E	—	EMA11E	—
F	EMA9F	—	EMA10F	—	EMA11F	—

Fanning Strips

Table 34-22. Fanning Strips

Frame Size	Reversing		Wye-Delta	
	Catalog Number	Price U.S. \$	Catalog Number	Price U.S. \$
A	EMFRA	—	EMFWA	—
B	EMFRB	—	EMFWB	—
C	EMFRC	—	EMFWC	—
D	EMFRD	—	EMFWD	—
E	EMFRE	—	EMFWE	—
F	EMFRF	—	EMFWF	—

Ring Terminals

Consult factory.

Reversing Kits

Includes Fanning Strips, Mechanical Interlock, Mounting Plate and hardware.

Table 34-23. Reversing Kits

Frame Size	Description	Catalog Number	Price U.S. \$
B	For Contactor and Starter	EMRKTB	—
C	For Contactor and Starter	EMRKTC	—
D	For Contactor and Starter	EMRKTD	—
E	For Contactor and Starter	EMRKTE	—
F	For Contactor	EMRCKTF	—
F	For Starter	EMRSKTF	—

Note: Also order separately the appropriate contact blocks and overload relay.

Starter Network Adapter Product (SNAP)

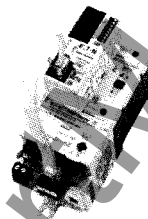

The Starter Network Adapter Product (SNAP) is a front-mount device that serves as a single node (DeviceNet or Quick Connect Port) device, providing communication capability, control and monitoring to Eaton's Cutler-Hammer Intelligent Technologies (*IT*). Electromechanical Starters (B – F Frames) as well as the *IT*. S751 SoftStart.

Cat. No. QSNAP with 54 mm IT. Starter

For more information and pricing, see Publication No. CA03305001E.

Cover Control Products



IT. MCC Cover Control

The Cover Control Products connect to the *IT*. Electromechanical Starters and to the *IT*. S751 SoftStart Product, providing breaker actuation control for a multitude of breaker/fuse options, cover control options

and communications capabilities. Moreover, the products extend the feature set of the *IT*. Electromechanical Starters and S751 SoftStart products.

For more information and pricing, see Publication No. CA03305001E.

March 2002

17. Electro-Mechanical Line

Contact Kits

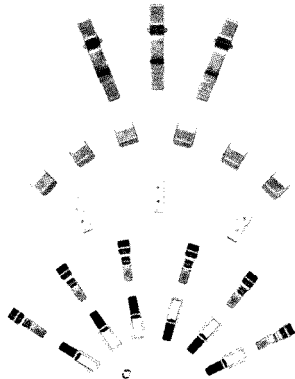

Table 34-24. Contact Kits

Frame Size	Contact Kit Description	Catalog Number	Price U.S. \$
C	40 Amp	EMCKT40	—
C	50 Amp	EMCKT50	—
D	65 Amp	EMCKT65	—
D	85 Amp	EMCKT85	—
D	100 Amp	EMCKT100	—
E	125 Amp	EMCKT125	—
E	160 Amp	EMCKT160	—
E	200 Amp	EMCKT200	—
F	250 Amp	EMCKT250	—
F	315 Amp	EMCKT315	—
F	400 Amp	EMCKT400	—

Coils



Table 34-25. Coils

Description ①	Catalog Number	Price U.S. \$
C-Frame Coil	EMCC	—
D-Frame Coil	EMCD	—
E-Frame Coil	EMCE	—
F-Frame Coil	EMCF	—

① For reversing contactors and starters, order two.

Din Rail Catch

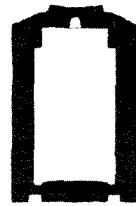

Table 34-26. DIN Rail Catch

Frame Size	Description	Catalog Number	Price U.S. \$
B - C	Catch with Leaf Spring & Pad	EMDRCB	—
D	Catch with Leaf Spring & Pad	EMDRCD	—

Lugs

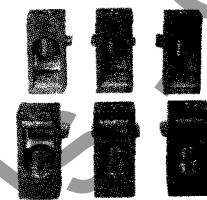

Table 34-27. Lug Kits

Frame Size	Description	Catalog Number	Price U.S. \$
C	Lug	EMLUGKTC	—
D	Lug	EMLUGKTD	—
E	Lug	EMLUGKTE	—
F	Horizontal Box Lug Kit	EMLUGKTFA	—
F	Vertical Box Lug Kit	EMLUGKTFB	—
F	Dual Lug Kit	EMLUGKTFC	—

Bus Bars



Table 34-28. Bus Bars

Frame Size	Description	Catalog Number	Price U.S. \$
B	For Contactors & Starters	EMBBB	—
C	For Starters	EMBBC	—
C	For Reversing Contactors & Reversing Starters	EMBBRC	—
D	For Starters	EMBBD	—
D	For Reversing Contactors & Reversing Starters	EMBBRD	—
E	For Starters	EMBBE	—
E	For Reversing Contactors & Reversing Starters	EMBBRE	—
F	Overload Relay	EMBBOF	—

Discount Symbol 1CD1

17. Electro-Mechanical Line

Connectors



34

Table 34-29. Control Terminal Connectors

No. of Pins	Pitch (mm)	Terminals	Description	Frame Size	Used With ②	Catalog Number ●	Price U.S. \$
4	5	-- PF	27 mm Contactor	A	E11A _ X3N	EMA78	—
5	5	-- PFR	27 mm Reversing Contactor	A or F	E511A _ S3N	EMA77	—
4	5	-- PF	45 mm, 54 mm Coil Controller	B - C	_ 02N _ XCXNN	EMA78L	—
8	5	-- PFR 1 2 3	76 mm, 105 mm Coil Controller	B - F	_ 02N _ XCXNN	EMA76L	—
8	5	-- PFR 1 2 3	Reversing Coil Controller	B - F	_ 03N _ XCXNN	EMA76L	—
8	5	-- PFR 1 2 3	Overload (except 27 mm and 140 mm)	B - E	_ 05N _ XR _ 3A	EMA76L	—
8	5	-- PFR 1 2 3	Reversing Overload (except 27 mm and 140 mm)	B - E	_ 06N _ XR _ 3A	EMA76L	—
(1) 5	5	-- PFR	140 mm Contactor	F	_ 111F _ X3N	EMA77L	—
(1) 5	5	RFP+-	140 mm Contactor	F	_ 111F _ X3N	EMA77L	—
(2) 5	5	-- PFR	140 mm Reversing Contactor	F	_ 511F _ X3N	EMA77L	—
(2) 5	5	RFP+-	140 mm Reversing Contactor	F	_ 511F _ X3N	EMA77L	—
(1) 8	5	-- PFR 1 2 3	140 mm Overload	F	_ 05NFXR _ 3A	EMA76L	—
(1) 5	5	RFP+-	140 mm Overload	F	_ 05NFXR _ 3A	EMA76L	—
(1) 8	5	-- PFR 1 2 3	140 mm Reversing Overload	F	_ 05NFXR _ 3A	EMA76L	—
(1) 5	5	RFP+-	140 mm Reversing Overload	F	_ 05NFXR _ 3A	EMA76L	—
(1) 8	5	-- PFR 1 2 3	140 mm Reversing Overload	F	_ 501F _ _ 3A	EMA76L	—
(2) 5	5	RFP+-	140 mm Reversing Overload	F	_ 501F _ _ 3A	EMA76L	—
(1) 5	5	-- PFR	140 mm Reversing Overload	F	_ 501F _ _ 3A	EMA77L	—
7	3.5	—	—	A	—	EMA79	—
8	3.5	—	—	A	—	EMA79L	—
7	3.5	—	—	A	—	EMA80	—
8	3.5	—	—	A	—	EMA80L	—
6	3.5	—	—	A	—	EMA81L	—

① Suffix L indicates locking.

② _ indicates missing digit of the Catalog Number; may have multiple values.

Overload and Coil Controller Covers

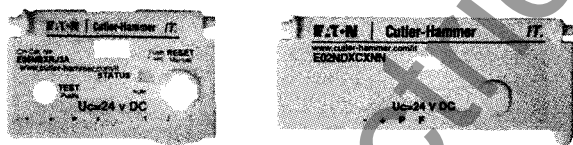

Table 34-30. Overload and Coil Controller Covers

Frame Size	Description	Catalog Number	Price U.S. \$
A	For Non-reversing Starters	EMOCSA	—
A	For Reversing Starters	EMOCRSA	—
B	For Starters	EMOCSE	—
B	For Reversing Contactors	EMCCSE	—
C	For Starters	EMOCSC	—
C	For Reversing Contactors	EMCCSC	—
D	For Starters	EMOCSD	—
D	For Contactors	EMCCSD	—
E	For Starters	EMOCSE	—
E	For Contactors	EMCCSE	—
F	For Starters	EMOCSE	—
F	For Contactors	EMCCSE	—

Discount Symbol 1CD1

March 2002

17. Electro-Mechanical Line

Non-reversing and Reversing Contactors (Frame A)

Table 34-31. Approximate Dimensions in Inches (mm)

Frame Size	Overall					Mounting Holes				Req. Mtg. Screws	Terminals		
	Width	Height	Depth	Depth w/ Auxiliary	Depth added w/ DIN Rail	Width	Height	Mtg. Hole to Top	DIN Rail to Top		Control	Line	Load
	A	B	C	D	E	F	G	H	J	K	P	Q	R
Non-reversing													
A	1.1 (27)	3.0 (75)	2.4 (60)	3.5 (88)	.2 (5)	.76 (19.2)	2.64 (67)	.1 (3.5)	.6 (15)	(3) #8 M4	.6 (16)	1.7 (43)	1.7 (43)
Reversing													
A	2.4 (60)	2.9 (73)	2.4 (60)	3.5 (88)	.2 (5)	1.31 (33.2)	2.52 (64)	.2 (5)	.5 (13)	(3) #8 M4	.6 (16)	1.7 (43)	1.7 (43)

34

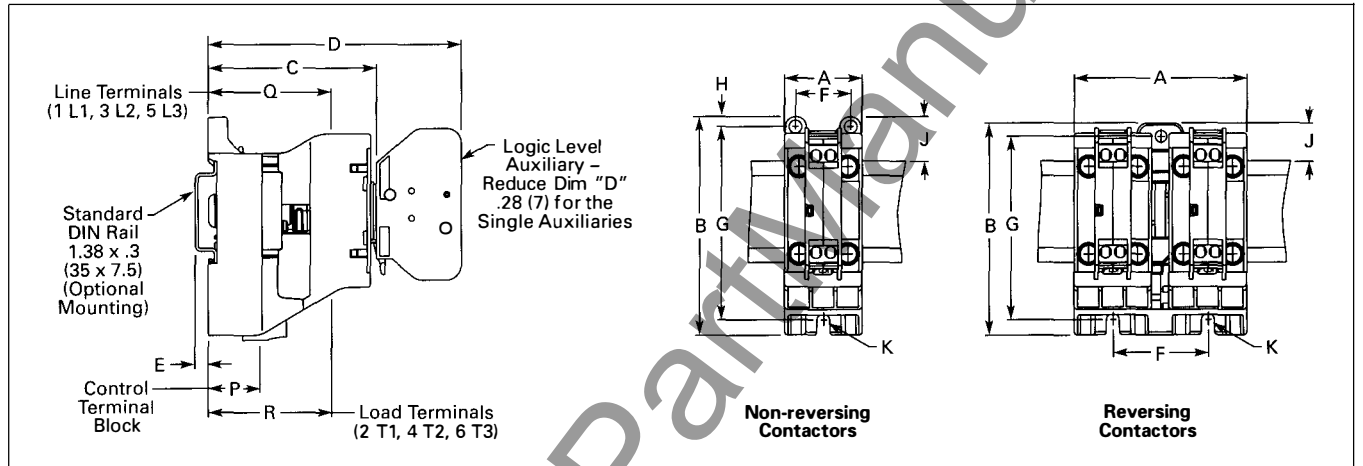

Figure 34-6. Approximate Dimensions — Inches (mm)

IT Electro-Mechanical Line

Non-reversing Contactors (Frames B & C)

Table 34-32. Approximate Dimensions in Inches (mm)

Frame Size	Overall					Mounting Holes				Req. Mtg. Screws	Terminals		
	Width	Height	Depth	Depth w/ Auxiliary	Depth added w/ DIN Rail	Width	Height	Mtg. Hole to Top	DIN Rail to Top		Control	Line	Load
	A	B	C	D	E	F	G	H	J		P	Q	R
B	1.8 (45)	4.4 (111)	2.4 (60)	3.6 (91)	.1 (3)	1.33 (33.8)	4.0 (101)	.2 (5)	.9 (23)	(3) #8 M4	.7 (19)	1.2 (30)	1.2 (30)
C	2.1 (54)	4.45 (113)	2.4 (60)	3.6 (91)	.1 (3)	1.46 (37)	4.1 (104)	.2 (5)	.8 (20)	(3) #8 M4	.7 (19)	1.2 (30)	1.2 (30)

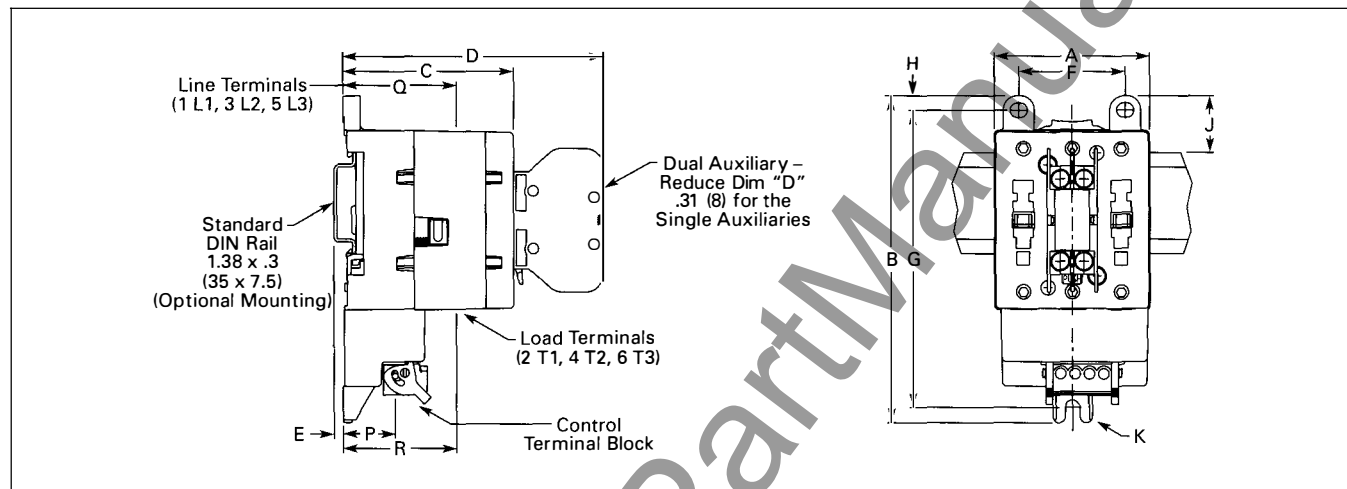

Figure 34-7. Approximate Dimensions — Inches (mm)

March 2002

17. Electro-Mechanical Line

Non-reversing Contactors (Frames D & E) ①

Table 34-33. Approximate Dimensions in Inches (mm)

Frame Size	Overall					Mounting Holes				Req. Mtg. Screws	Terminals		
	Width	Height	Depth	Depth w/ Auxiliary	Depth added w/ DIN Rail	Width	Height	Mtg. Hole to Top	DIN Rail to Top		Control	Line	Load
	A	B	C	D	E	F	G	H	J		P	Q	R
D	3.0 (76)	5.9 (150)	3.1 (79)	4.2 (107)	.2 (4)	.94 (24)	2.87 (73)	.5 (13)	.9 (23)	(4) #6 x 2 M3.5 x 50	2.4 (60)	1.5 (37)	.6 (14)
E	4.1 (105)	8.0 (203)	3.5 (90)	4.7 (119)	—	1.33 (33.8)	4.13 (105)	.6 (15)	—	(4) #8 x 1.5 M4 x 40	2.8 (72)	1.7 (42)	.3 (8)

① Frame F, consult factory.

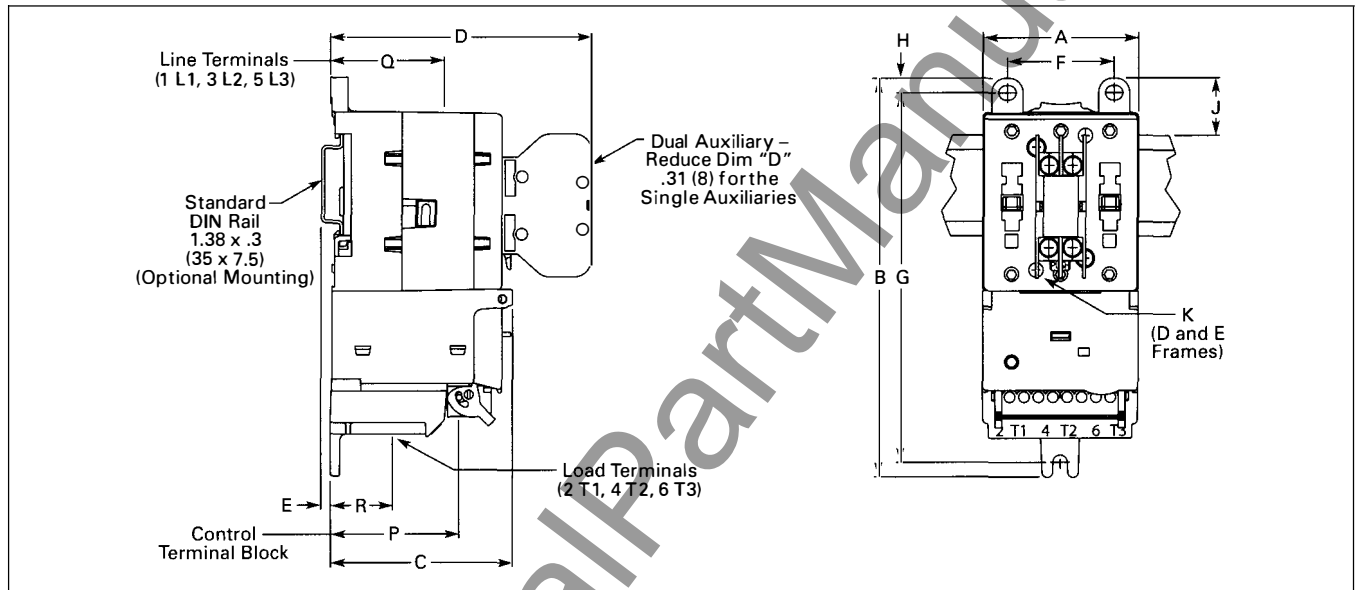

Figure 34-8. Approximate Dimensions — Inches (mm)

17. Electro-Mechanical Line

Reversing Contactors (Frames B – E) ①

Table 34-34. Approximate Dimensions in Inches (mm)

Frame Size	Overall					Mounting Holes				Req. Mtg. Screws	Terminals		
	Width	Height	Depth	Depth w/ Auxiliary	Depth added w/ DIN Rail	Width	Height	Mtg. Hole to Top	DIN Rail to Top		Control	Line	Load
	A	B	C	D	E	F	G	H	J		P	Q	R
B	3.8 (96)	5.9 (149)	2.7 (69)	3.8 (96)	—	3.15 (80)	5.35 (136)	.3 (7)	—	(3) #10 M5	2.0 (50)	1.5 (38)	.9 (22)
C	4.5 (114)	5.9 (149)	2.6 (67)	3.8 (96)	—	3.15 (80)	5.35 (136)	.3 (7)	—	(3) #10 M5	2.0 (50)	1.5 (38)	.6 (16)
D	6.2 (158)	7.4 (188)	3.3 (84)	4.4 (112)	—	5.51 (140)	6.89 (175)	.2 (6)	—	(3) #10 M5	2.6 (67)	1.9 (48)	.9 (22)
E	8.5 (216)	9.5 (242)	3.8 (97)	4.9 (125)	—	7.87 (200)	9.06 (230)	.2 (6)	—	(3) #10 M5	3.1 (80)	2.1 (54)	.7 (17)

① Frame F, consult factory.

34

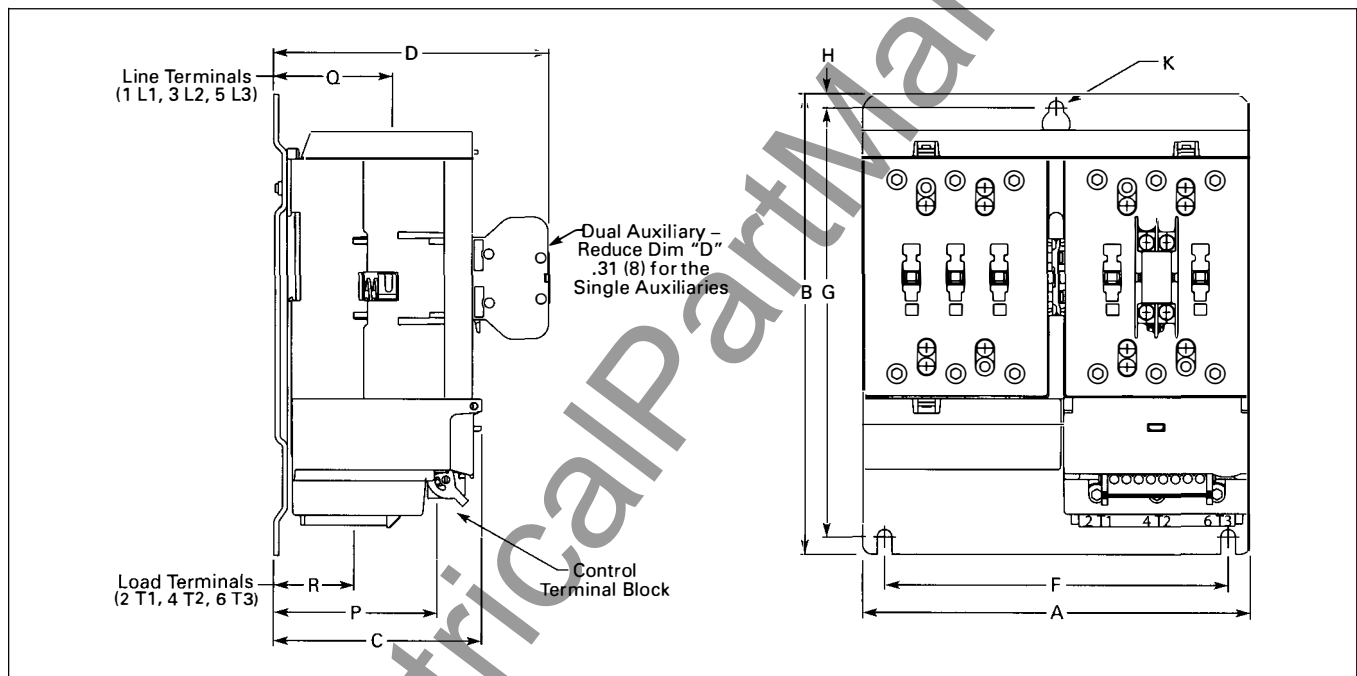

Figure 34-9. Approximate Dimensions — Inches (mm)

March 2002

IT. Electro-Mechanical Line

Non-reversing Starters (Frames B – E) ①

Table 34-35. Approximate Dimensions in Inches (mm)

Frame Size	Overall					Mounting Holes				Req. Mtg. Screws	Reset Button			Terminals		
	Width	Height	Depth	Depth w/ Auxiliary	Depth added w/ DIN Rail	Width	Height	Mtg. Hole to Top	DIN Rail to Top		Width	Height	Depth	Control	Line	Load
	A	B	C	D	E	F	G	H	J		L	M	N	P	Q	R
B	1.8 (45)	5.0 (127)	2.5 (63)	3.6 (91)	.1 (3)	1.33 (33.8)	4.62 (117.3)	.2 (5)	.9 (23)	(3) #8 M4	.6 (14)	3.6 (91)	2.5 (63)	1.7 (44)	1.2 (30)	.6 (16)
C	2.1 (54)	5.4 (138)	2.5 (63)	3.6 (91)	.1 (3)	1.46 (37)	5.04 (128)	.2 (5)	.8 (20)	(3) #8 M4	.7 (17)	3.7 (93)	2.4 (62)	1.8 (45)	1.2 (30)	.3 (8)
D	3.0 (76)	5.9 (150)	3.1 (79)	4.2 (107)	.2 (4)	.94 (24)	2.87 (73)	.5 (13)	.9 (23)	(4) #6 x 2 M3.5 x 50	.7 (17)	4.2 (106)	3.1 (78)	2.4 (60)	1.5 (37)	.6 (14)
E	4.1 (105)	8.0 (203)	3.5 (90)	4.7 (119)	—	1.33 (33.8)	4.13 (105)	.6 (15)	—	(4) #8 x 1.5 M4 x 40	.7 (17)	5.7 (146)	3.5 (88)	2.8 (72)	1.7 (42)	.3 (8)

① Frame F, consult factory.

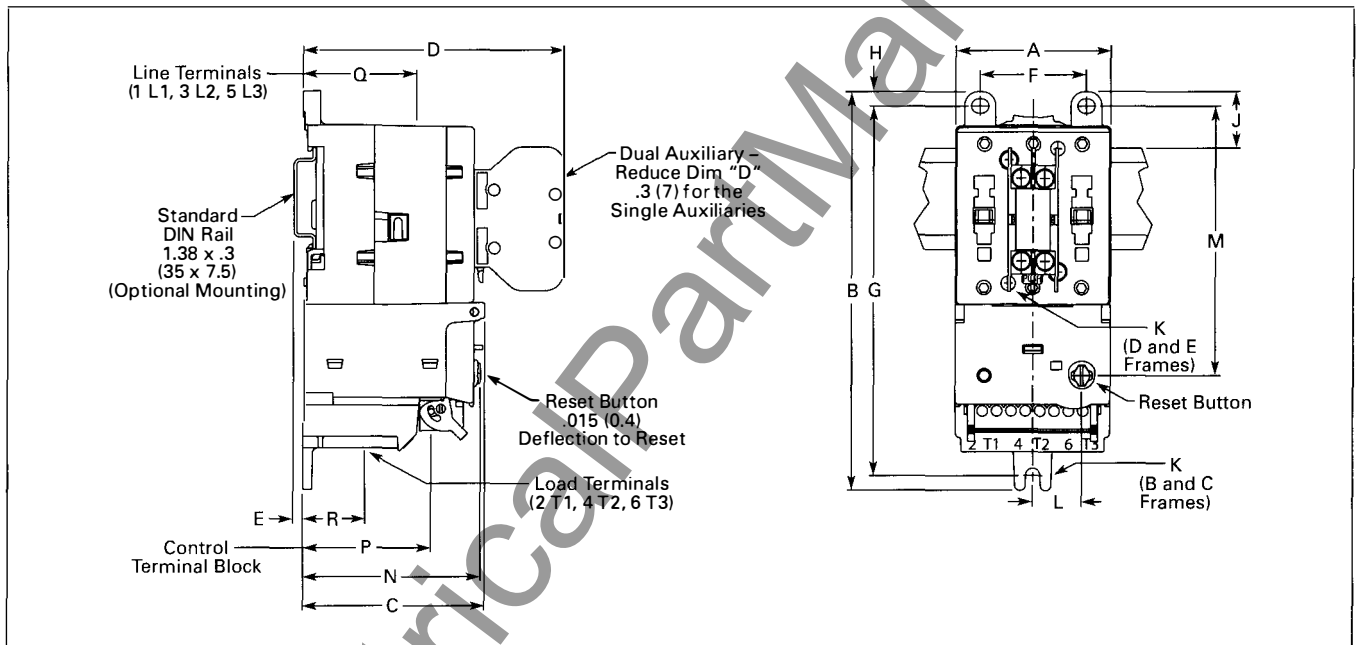

Figure 34-10. Approximate Dimensions — Inches (mm)

17. Electro-Mechanical Line

Reversing Starters ①

Table 34-36. Approximate Dimensions in Inches (mm)

Frame Size	Overall					Mounting Holes				Req. Mtg. Screws	Reset Button			Terminals		
	Width	Length	Depth	Depth w/ Auxiliary	Depth added w/ DIN Rail	Width	Height	Mtg. Hole to Top	DIN Rail to Top		Width	Height	Depth	Control	Line	Load
	A	B	C	D	E	F	G	H	J		K	L	M	N	P	Q
B	3.8 (96)	5.9 (149)	2.7 (69)	3.8 (96)	—	3.15 (80)	5.35 (136)	.28 (7)	—	(3) #10 M5	1.6 (40)	3.8 (97)	2.7 (68)	2.0 (50)	1.5 (38)	.9 (22)
C	4.5 (114)	5.9 (149)	2.6 (67)	3.8 (96)	—	3.15 (80)	5.35 (136)	.28 (7)	—	(3) #10 M5	1.7 (43)	4.1 (104)	2.6 (65)	2.0 (50)	1.5 (38)	.6 (16)
D	6.2 (158)	7.4 (188)	3.3 (84)	4.4 (112)	—	5.51 (140)	6.89 (175)	.24 (6)	—	(3) #10 M5	2.3 (58)	5.5 (139)	3.3 (83)	2.6 (67)	1.9 (48)	.9 (22)
E	8.5 (216)	9.5 (242)	3.8 (97)	4.9 (125)	—	7.87 (200)	9.06 (230)	.24 (6)	—	(3) #10 M5	2.9 (73)	7.2 (182)	3.7 (94)	3.1 (80)	2.1 (54)	.7 (17)

① Frame F, consult factory.

34

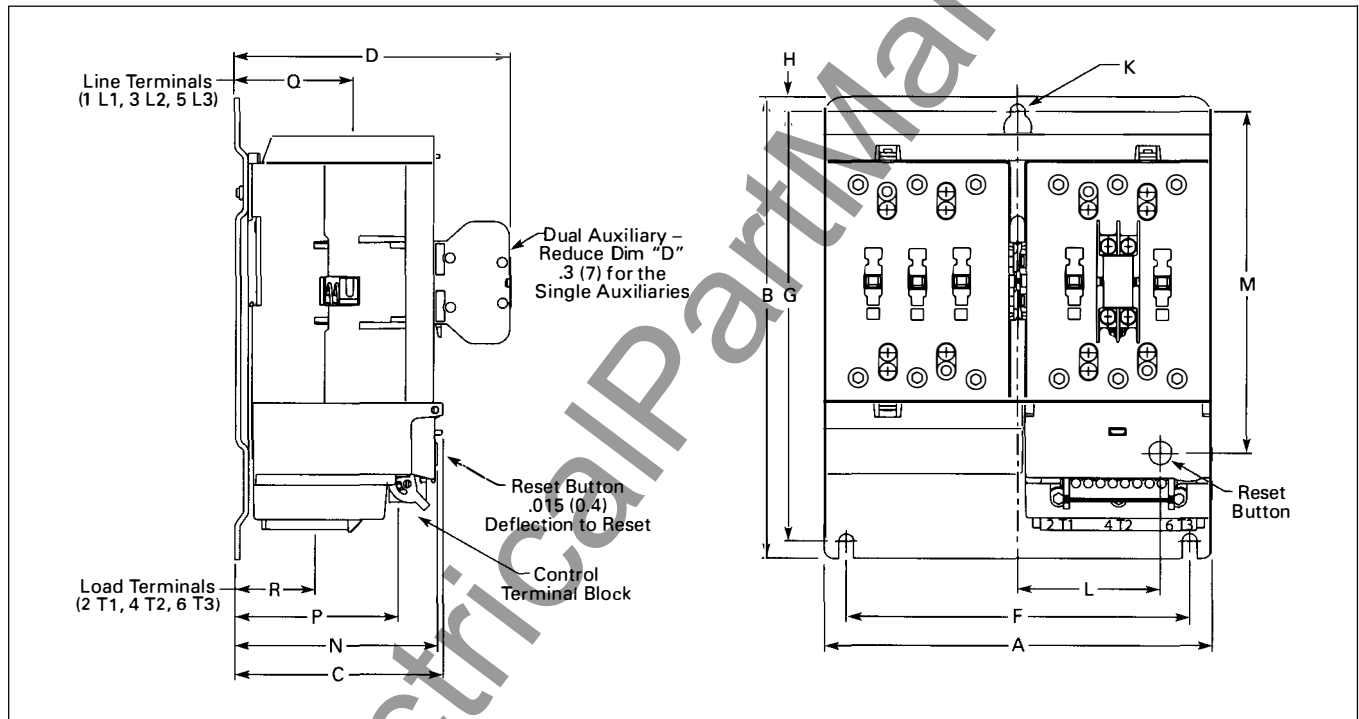

Figure 34-11. Approximate Dimensions — Inches (mm)

March 2002

www.ElectricalPartManuals.com

www.ElectricalPartManuals.com

Eaton Corporation
Cutler-Hammer business unit
1000 Cherrington Parkway
Moon Township, PA 15108-4312
USA
tel: 1-800-525-2000
www.cutler-hammer.eaton.com

EAT•N

Cutler-Hammer

© 2002 Eaton Corporation
All Rights Reserved
Printed in USA
Publication No. CA03403002E
March 2002