



SWITCHGEAR

RENEWAL PARTS ORDERING GUIDE

TYPES LA-3000 and LA-4000F

**AIR CIRCUIT BREAKER
WITH
MANUAL OR ELECTRICAL
OPERATORS**

**HOW TO USE YOUR
RENEWAL PARTS ORDERING GUIDE**

1. Locate the part or parts to be replaced in one of the drawings in this manual
2. Identify each part by item number, description and part number. Give drawing figure number in which part is shown.
3. Include breaker type, rating and breaker serial number with your order.
4. Place order with your Allis-Chalmers representative.
5. When ordering relays or other electrical parts, include control voltage (see recommended spare parts list for part numbers).

ORDERING EXAMPLE

Type	<u>LA-3000</u>	Rated Amps	<u>3000</u>	Serial Number	<u>H-66679A-4</u>
Mode of Operation:	<input checked="" type="checkbox"/> Electrical		<input type="checkbox"/> Manual		
Renewal Parts Ordering Guide	<u>18X4560</u>				
<u>Fig</u>	<u>Item</u>	<u>Description</u>	<u>Part Number</u>	<u>Quantity</u>	
1	6	Barrier	71-142-324-001	1	
3	24	Spring	71-141-666-001	1	
2	28	Base	71-340-240-001	1	

If required part is not identified in this manual -----

1. Make a copy of the drawing figure in which the part would appear.
2. Indicate with arrows or other markings location of part.
3. Describe or sketch required part.
4. Include breaker type, rating and breaker serial number with your order.
5. Place order with your Allis-Chalmers representative.

TABLE OF CONTENTS

	<u>Drawing No.</u>	<u>Figure</u>	<u>Page</u>
Air Circuit Breaker	18-384-479-601	1	1
Operator Mechanism and Panel Assembly	18-717-776-520	2	2
Operator Mechanism Assembly - Externally Mounted Parts	18-384-479-501	3	4
Operator Mechanism Assembly - Internally Mounted Parts	18-384-480-501	4	6

USAGE CODE TABLE

Type	Application	Operator	Top Level Assembly	Usage Code*
LA-3000	3000 AMP	Electrical	18-384-479-601	A
LA-4000	4000 AMP	Electrical	18-384-480-601	B
LA-4000F	5000 & 6000 AMP	Electrical-Fused	18-384-480-611	C
LA-4000F	3000 & 4000 AMP	Electrical-Fused	18-384-480-612	D

* If no usage code appears in the "USAGE" column of the following parts lists, the part is used on all assemblies listed in the figure title.

ITEM	DESCRIPTION	PART NUMBER	USAGE	ITEM	DESCRIPTION	PART NUMBER	USAGE
1	Arc Chute	71-340-247-501		10	Bar	71-240-629-001	CD
2	Cover Assy.	18-657-359-556	A	11	Washer	71-105-182-016	A
	Cover Assy.	18-657-359-561	B		Washer	71-105-182-017	BCD
	Cover Assy.	18-657-349-558	CD	12	Decal	71-141-867-001	
3	Primary Disconnect	18-657-511-578	A	13	Shim	71-109-563-002	CD
	Primary Disconnect	18-657-511-579	BCD	14	Support	71-142-108-001	
4	Contact Block	71-240-625-501	CD	15	Bar	71-142-252-001	CD
5	Bar Assy.	71-141-292-501	A	16	Bracket	71-142-281-001	
	Bar Assy.	71-141-292-502	BCD	17	Bracket	71-142-256-001	CD
6	Shield	71-142-324-001		18	Bracket	71-142-256-002	CD
7	Barrier	71-240-434-001	AB	19	Barrier	71-142-257-001	CD
	Barrier	71-240-434-002	CD	20	Bar	71-142-290-001	CD
8	Leg	71-142-291-001	CD	21	Channel	71-142-431-001	
9	Bar	71-240-628-001	CD	22	Fuse	71-142-200	CD

(See Parts List)

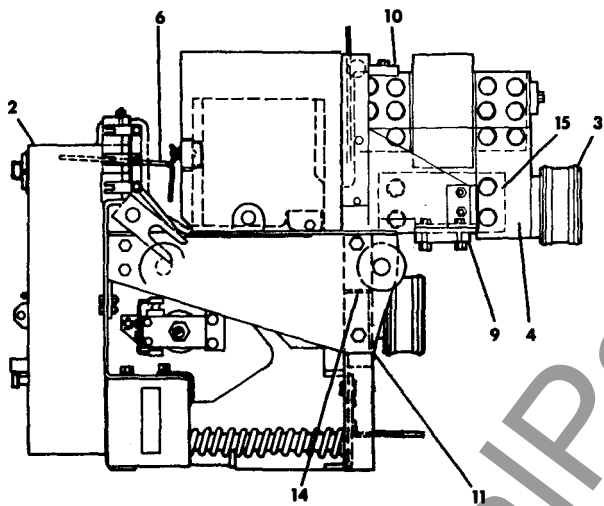

Right Side View
LA-4000 Fused

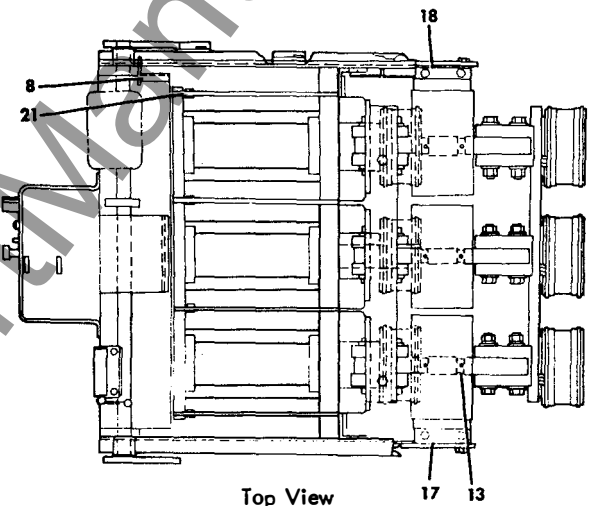

Top View
LA-4000 Fused

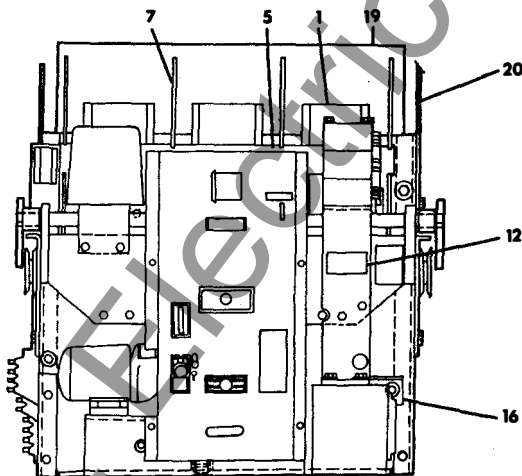

Front View
LA-3000 & LA-4000

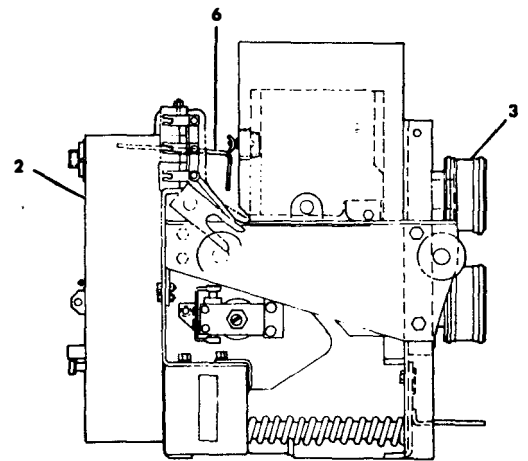

Right Side View
LA-3000 & LA-4000

Figure 1. Air Circuit Breaker

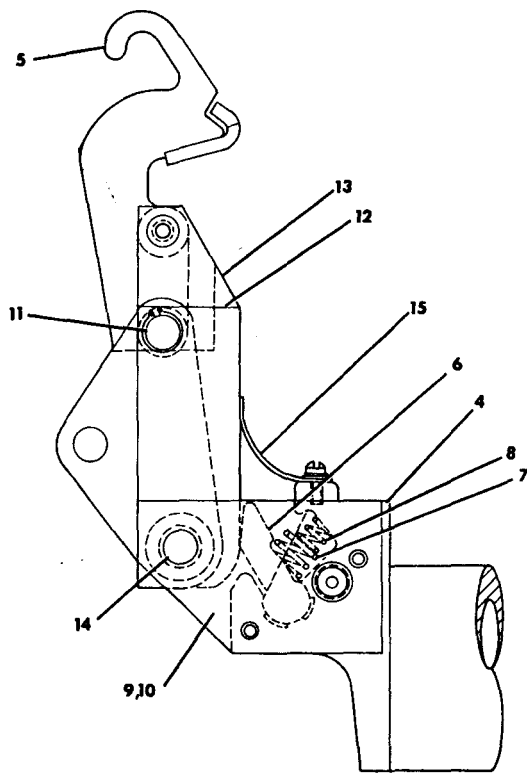

Detail B

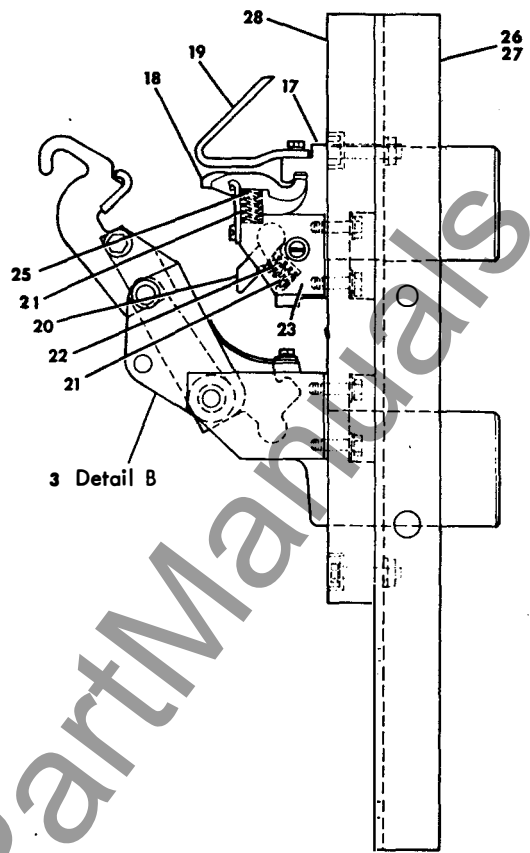

Detail A

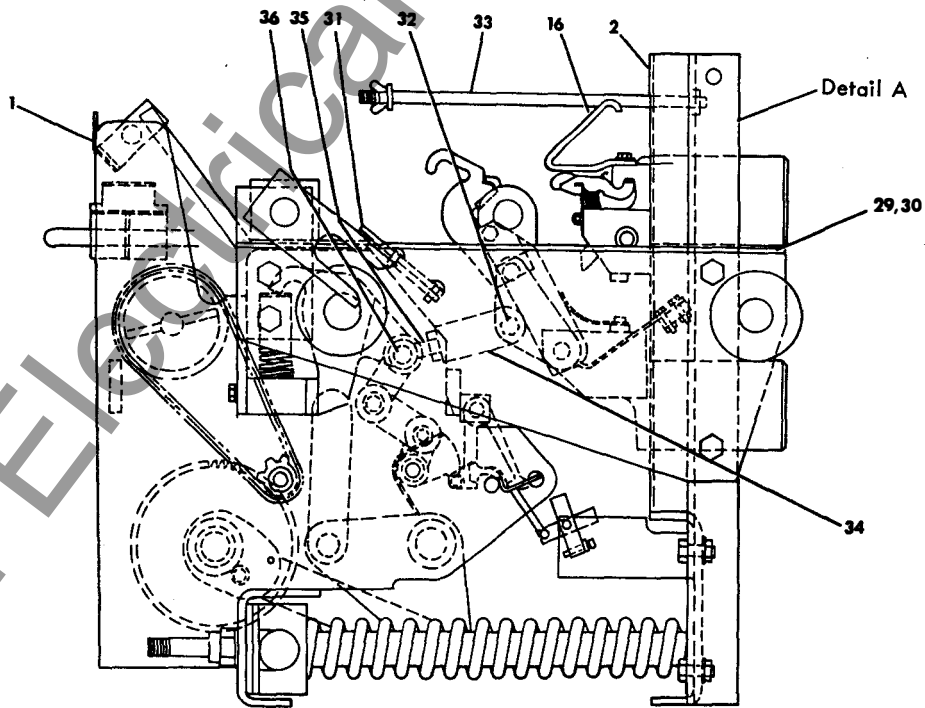

Detail A

Figure 2. Operator Mechanism and Panel Assembly

<u>ITEM</u>	<u>DESCRIPTION</u>	<u>PART NUMBER</u>	<u>USAGE</u>	<u>ITEM</u>	<u>DESCRIPTION</u>	<u>PART NUMBER</u>	<u>USAGE</u>
1	Operator Mechanism	18-384-479-501	A		Contact Assy., Upper	18-657-364-566	CD
	Operator Mechanism (See Figures 3 and 4)	18-384-480-501	BCD		(Includes items 17 thru 25)		
2	Contact & Base	18-657-349-550	A	17	Contact Block	71-141-095-501	A
	Contact & Base	18-657-358-502	B		Contact Block	71-141-480-501	B
	Contact & Base (Includes items 4 thru 25)	18-657-364-565	CD	18	Contact Block	71-240-626-501	CD
3	Contact Assy., Lower	18-657-349-559	A		Arcing Contact Assy.	71-141-172-501	A
	Contact Assy., Lower (Includes items 4 thru 15)	18-657-358-504	BCD		Arcing Contact Assy.	71-141-172-502	BCD
4	Contact Block, Lower	71-141-095-502	A	19	Arc Runner	71-240-486-001	
	Contact Block, Lower	71-141-480-502	BCD	20	Main Contact Finger	71-140-016-001	A
5	Arcing Contact Assy.	71-141-115-501	A		Main Contact Finger	71-141-489-501	BCD
	Arcing Contact Assy.	71-141-115-502	BCD	21	Contact Finger Spring	71-140-019-001	
6	Main Contact Finger	71-140-016-001		22	Contact Finger Spring	71-140-131-001	
7	Contact Finger Spring	71-140-019-001		23	Side Plate	71-140-767-001	
8	Contact Finger Spring	71-140-131-001		24	Compression Spring	71-141-174-001	
9	Support, L. H.	71-141-093-001		25	Compression Spring	71-141-173-001	
10	Support, R. H.	71-141-093-002		26	Angle L. H.	71-340-241-001	AB
11	Pin	71-141-281-004	A		Angle L. H.	71-340-241-003	CD
	Pin	71-141-496-001	BCD	27	Angle R. H.	71-340-241-002	AB
12	Contact Bar	71-141-100-001	A		Angle R. H.	71-340-241-004	CD
	Contact Bar	71-141-495-501	BCD	28	Base	71-340-240-001	A
13	Contact Bar	71-141-101-001	A		Base	71-340-300-001	B
	Contact Bar	71-141-495-502	BCD		Base	71-340-320-001	CD
14	Shaft	71-141-151-001	A	29	Side Plate R. H.	18-723-570-503	
	Shaft	71-141-151-003	BCD	30	Side Plate L. H.	18-723-570-502	
15	Shield	71-141-164-001	A	31	Barrier	71-141-241-001	A
	Shield	71-141-164-003	BCD		Barrier	71-141-480-001	B
16	Contact Assy., Upper	18-657-349-553	A		Barrier	71-141-486-001	CD
	Contact Assy., Upper	18-657-358-503	B	32	Pin	71-141-281-001	
				33	Rod	71-166-194-028	
				34	Rod	71-141-112-001	
				35	Rod End	71-141-114-001	
				36	Pin	71-141-281-002	

Figure 2. Operator Mechanism and Panel Assembly

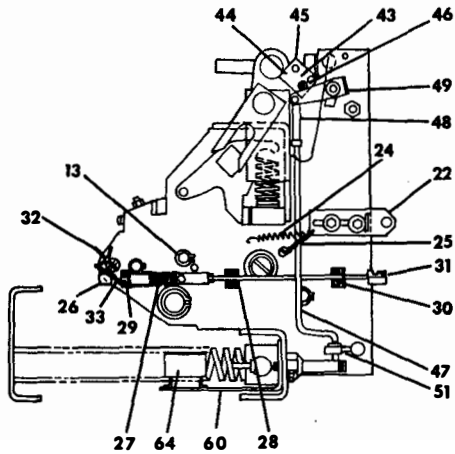

Left Hand Side View

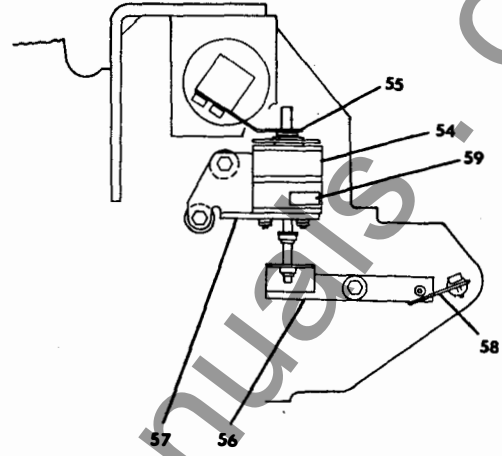

Detail A

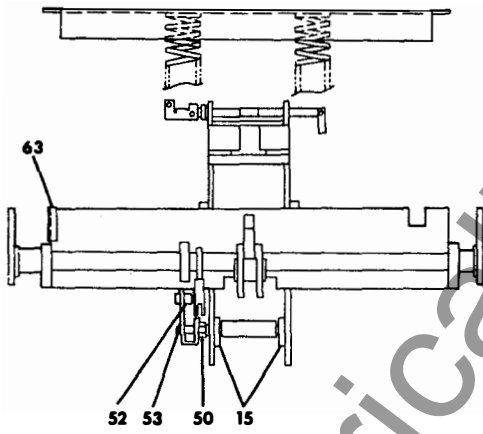

Plan View

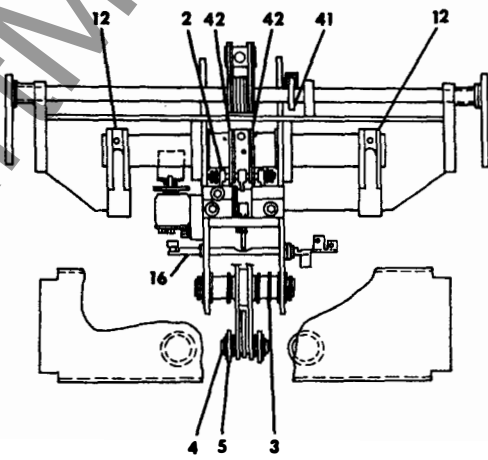

Rear View

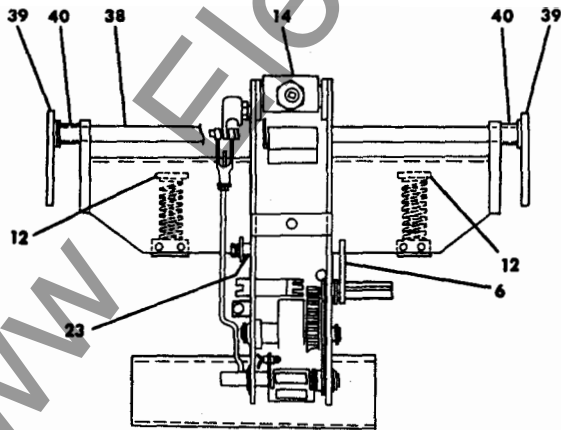

Front View

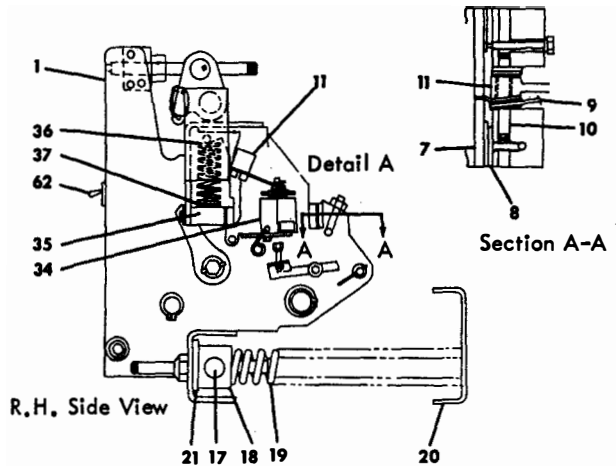

R.H. Side View

Section A-A

Figure 3. Operating Mechanism - Externally Mounted Parts

ITEM	DESCRIPTION	PART NUMBER	USAGE	ITEM	DESCRIPTION	PART NUMBER	USAGE
1	Frame Assy.	71-240-436-503	A	32	Trip Lever	71-142-341-001	
	Frame Assy.	71-240-436-504	BCD	33	Spring	71-141-311-001	
2	Link	71-141-140-002		34	Bumper	71-141-142-001	
3	Crank Assy.	71-141-208-501		35	Block	71-142-321-001	
4	Pin	71-100-614-004		36	Compression Spring	00-837-321-043	
5	Link	71-141-214-001		37	Shim	71-141-343-001	
6	Ratchet Assy.	72-140-255-501		38	Shaft	71-141-186-002	
7	Block	71-141-332-001		39	Crank	71-141-185-001	
8	Bumper	71-141-329-001		40	Pipe	71-105-260-011	
9	Spring	71-141-231-001		41	Crank	72-140-206-001	
10	Pin	71-240-127-013		42	Washer	18-657-461-283	A
11	Shaft	71-142-308-001		43	Spring	72-140-205-001	
12	Crank	71-340-245-002		44	Stud	15-171-048-001	
13	Pin	71-141-281-003		45	Lever	72-140-204-001	
14	Racking Mech	18-657-349-557		46	Tube	72-140-207-001	
15	Bearing	71-141-669-001		47	Rod	72-140-246-001	
16	Shaft	71-240-429-001		48	Yoke End Adj.	00-691-701-902	
17	Shaft	71-141-183-001		49	Lever	72-140-203-001	
18	Block	71-142-319-001		50	Shaft	72-140-209-001	
19	Spring	71-141-389-001		51	Eye End	72-140-247-001	
20	Channel Assy.	71-141-098-503	A	52	Clevis Pin	00-957-211-902	
	Channel Assy.	71-141-098-504	BCD	53	Stud	15-171-048-002	A
21	Bumper	71-141-180-001		54	Sealed Actuator	72-240-002-001	
22	Latch	71-141-663-002		55	Arm	71-142-400-001	
23	Spacer	71-141-664-001		56	Arm Assy.	71-142-399-501	
24	Spring	71-141-666-001		57	Bracket	71-142-384-001	
25	Spring	71-142-049-001		58	Arm	71-142-167-001	
26	Pin	71-142-393-001		59	Decal	72-140-002-001	
27	Compression Spring	71-204-605-009		60	Limit Switch Assy.	18-657-349-552	
28	Angle	71-141-216-002		61	Ground Bar	71-141-926-001	
29	Angle	71-141-216-003		62	Switch, SPST	00-871-523-008	
30	Angle	71-141-216-004		63	Channel	71-142-430-001	
31	Trip Rod	71-141-518-002		64	Switch	00-871-523-004	

Figure 3. Operating Mechanism - Externally Mounted Parts

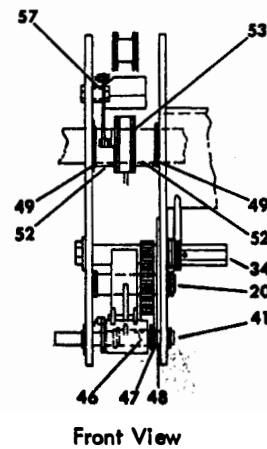
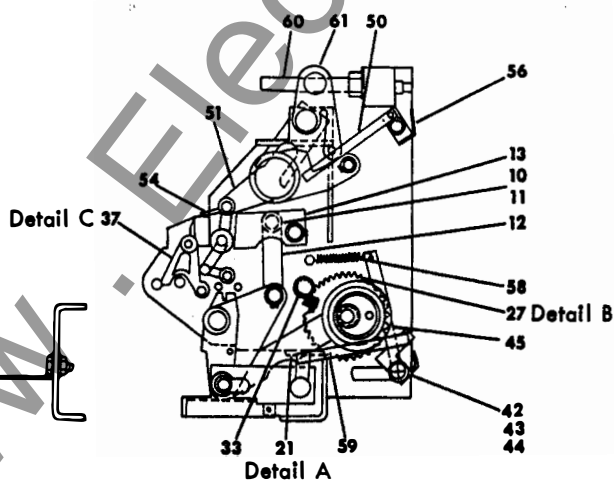
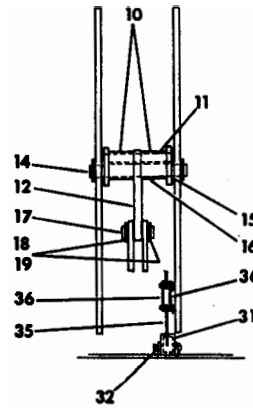
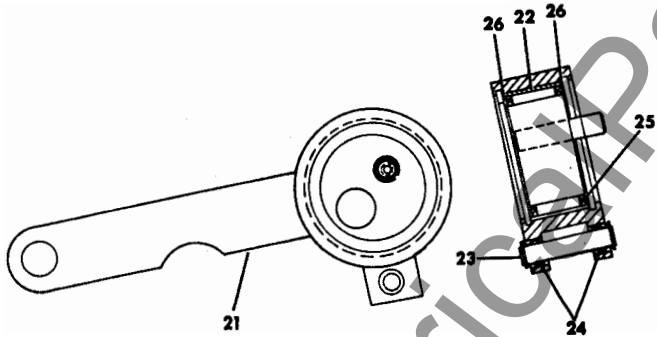
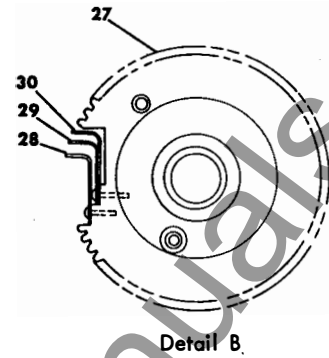
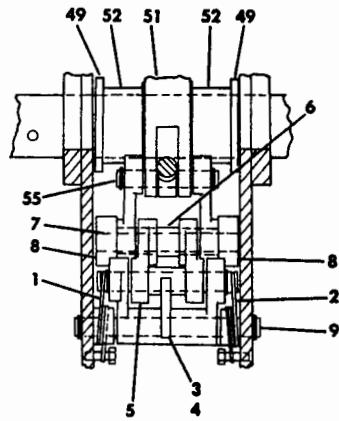
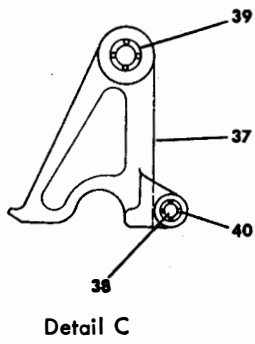

L.H. Side View - Without L.H. Side Plate

Figure 4. Operating Mechanism - Internally Mounted Parts

<u>ITEM</u>	<u>DESCRIPTION</u>	<u>PART NUMBER</u>	<u>USAGE</u>	<u>ITEM</u>	<u>DESCRIPTION</u>	<u>PART NUMBER</u>	<u>USAGE</u>
1	Spring R. H.	71-141-230-001		32	Clevis Pin	15-171-181-001	
2	Spring L. H.	71-141-230-002		33	Pinion	71-240-469-001	
3	Latch Crank	71-141-149-001		34	Adapter	72-140-275-001	
4	Needle Bearing	00-813-119-807		35	Eye End	00-691-713-101	
5	Tubing	71-170-491-009		36	Link	71-141-204-001	
6	Tubing	71-170-491-011		37	Latch	71-240-415-002	
7	Pin	71-240-127-012		38	Pin	71-240-127-022	
8	Roller	71-141-227-001		39	Needle Bearing	00-813-119-803	
9	Pin	71-240-127-011		40	Needle Bearing	15-813-119-001	
10	Tubing	71-169-020-014		41	Shaft	71-141-194-001	
11	Pin	71-141-196-001		42	Bracket	71-142-432-001	
12	Link	71-141-258-001		43	Indicator	71-141-815-003	
13	Cam	71-141-187-001		44	Indicator	71-141-815-004	
14	Pin	71-100-614-005		45	Latch	71-240-426-002	
15	Tubing	71-169-020-013		46	Tubing	71-169-020-018	
16	Tubing	71-169-020-015		47	Tubing	71-169-020-017	
17	Pin	71-100-614-003		48	Arm	71-240-437-001	
18	Bell Crank Assy.	71-141-126-501		49	Bearing	71-141-157-002	
19	Needle Bearing	00-813-119-821		50	Link	71-141-204-003	
20	Pin	71-240-127-014		51	Crank	71-240-475-001	
21	Connecting Rod Assy.	71-240-411-511		52	Spacer	71-142-322-001	
22	Inner Race	15-813-119-020		53	Pin	71-141-281-002	
23	Pin	71-240-127-009		54	Rod End	71-141-114-001	
24	Needle Bearing	00-813-119-805		55	Pin	71-240-127-010	
25	Needle Bearing	00-813-119-830		56	Indicator Assy.	71-141-120-503	
26	Washer	71-141-328-002		57	Spacer	71-015-176-037	
27	Gear	71-240-438-001		58	Spring	71-141-273-001	
28	Spring	71-141-224-001		59	Rod	71-141-191-001	
29	Spring	71-141-224-002		60	▼ Racking Mechanism Assy.	18-657-349-557	
30	Spring	71-141-224-003		61	Arm	71-240-468-001	
31	Latch Assy.	71-142-310-501					

Figure 4. Operating Mechanism - Internally Mounted Parts

www.ElectricalPartManuals.com