



# 100 ampere bus duct

application  
data

**30-566**

straight lengths, fittings, hangers

page 1

AIA File No. 31-6-621

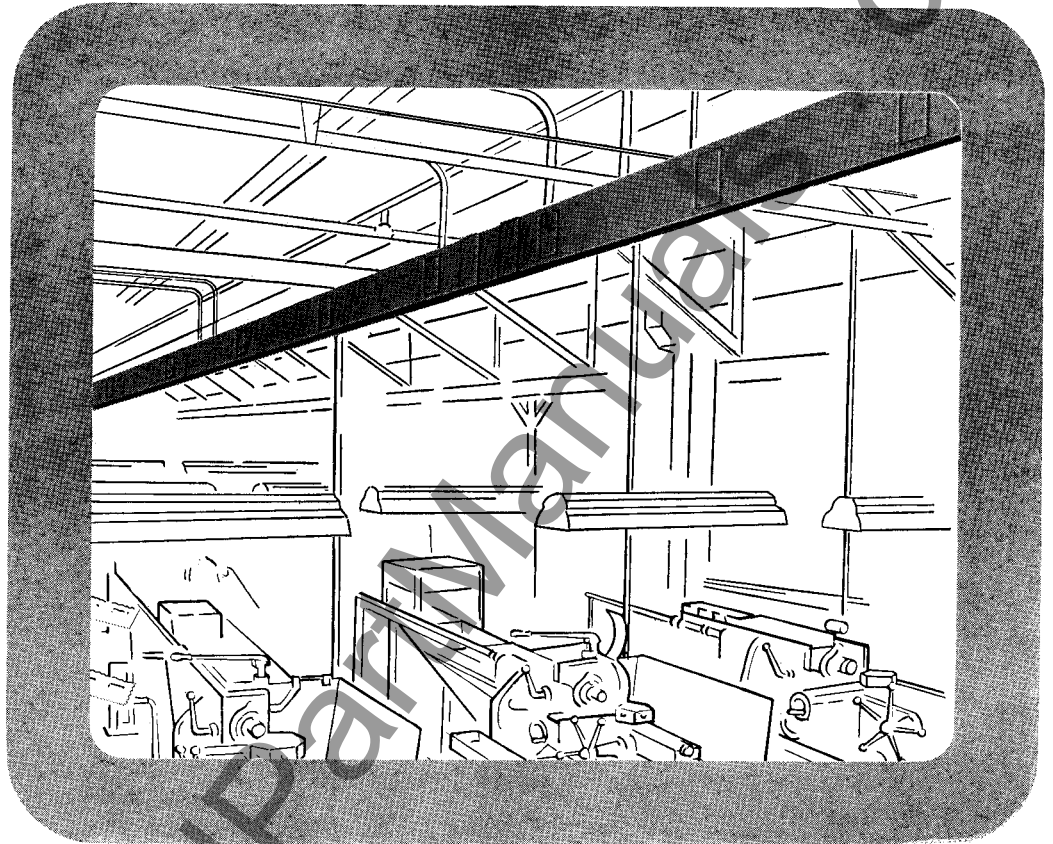
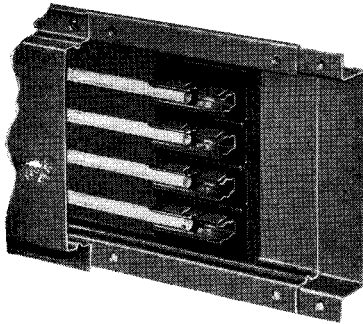

## in this section:

<b>description</b>	<b>page</b>
<b>general information</b>	2
<b>straight lengths</b>	
10 ft. sections	3
typical cross section	3
duct joint end	3
<b>fittings</b>	
elbows	4
tees	5
cable tap box	6
end closers	6
<b>hangers</b>	
clip-on	6
"C" clamp	6
<b>external handle operating mechanism</b>	6
<b>plug-in devices</b>	
circuit breakers	7
fusible	7
non-fusible	7
<b>voltage drop curve</b>	8
<b>typical specifications</b>	8

January, 1965

supersedes application data 30-666, pages 1-8, dated January 1, 1961  
mailed to: E/1136/DB; D/808/DB; C/315/AD

AIA File No. 31-6-621



## general information

10 foot section of 100 ampere bus duct

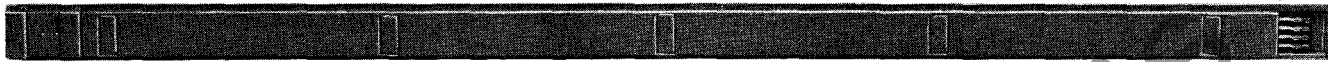

10 foot section with housing removed



## application

100 ampere-bus duct is the modern successor to conduit and cable in supplying small blocks of power for the normal commercial and industrial power systems. It also now makes bus duct practical for small shops, laboratories, garages and manual training class rooms. The number of possible applications for 100 ampere-bus duct is limited only by the imagination. A partial list would include motels, trailer courts, serve-yourself laundries, service entrance duct, T. V. studios, bakeries, auto repair garages, railroad shops, shopping centers and large and small businesses of every description.

The installed cost of 100 ampere-bus duct is competitive with that of conduit and cable. Overall advantages of a bus duct system such as flexibility, salvability, compactness, and convenience of making power take-offs make older distribution systems appear obsolete. Plug-in outlets are distributed efficiently along a Westinghouse 100 ampere-bus duct run providing power for operating small drill presses, punch presses, fluorescent lighting, small tools, portable welders, test benches, automatic food dispensers and other devices.

## construction

**conductors:** Electrical conductors are round aluminum rods plated with zinc, copper and silver. The housing is formed from two channels of 20 gauge steel riveted together in a solid assembly.

Conductor joints are made by means of boltless pressure clips which require no assembly or adjustment by the installer. The duct is not dependent upon the cover screws of the enclosure for maintaining the proper mechanical pressure to assure a good low resistance joint between electrical conductors of adjacent sections.

**supports:** The bus bars are firmly supported by molded insulators on alternate sides of the duct. Insulators are the type through which it is possible to fully isolate the stabs as well as to afford extra protection in the event of stresses due to a fault. Insulators are spaced so as to allow mounting of plug-in units opposite to each other without interference.

**enclosure:** The duct housing is of 20 gauge steel, bonderized both inside and out and given one coat of medium light gray (ASA-49) baked on enamel. The enclosure includes 10 plug-in outlets for ten foot lengths and includes two plug-in outlets on one foot lengths. Each plug-in outlet provides complete polarization of the plug-in outlet. All plug-in outlets are usable at the same time. The plug-in outlet is enclosed by a removable steel knockout cover. A replacement cover is available from Westinghouse when and if the user decides not to use the plug-in opening.

## standards

The bus duct is designed for 100 ampere capacity and is available for 1 $\varnothing$  3W, 3 $\varnothing$  3W, and 3 $\varnothing$  4W applications. Westinghouse 100 ampere bus duct is manufactured in accordance with Underwriters' Laboratories, Inc. requirements. This bus duct is also manufactured in accordance with NEMA standards for bus duct short circuit withstanding strength, which is 10,000 amperes.

# 100 ampere bus duct

straight lengths, fittings, hangers

application data

30-566

page 3

## straight lengths

Available in lengths of 10 feet, 5 feet, 3 feet, 2 feet and 1 foot with plug-in outlets included in all lengths. Plug-in outlets are made usable by removal of a steel knockout cover. Outlet covers are available for covering exposed outlets when a plug-in unit is relocated.

straight length in feet	number of outlets
10	10
5	6
3	4
2	2
1	2

note: All plug outlets are usable simultaneously.

10 foot section top and front views

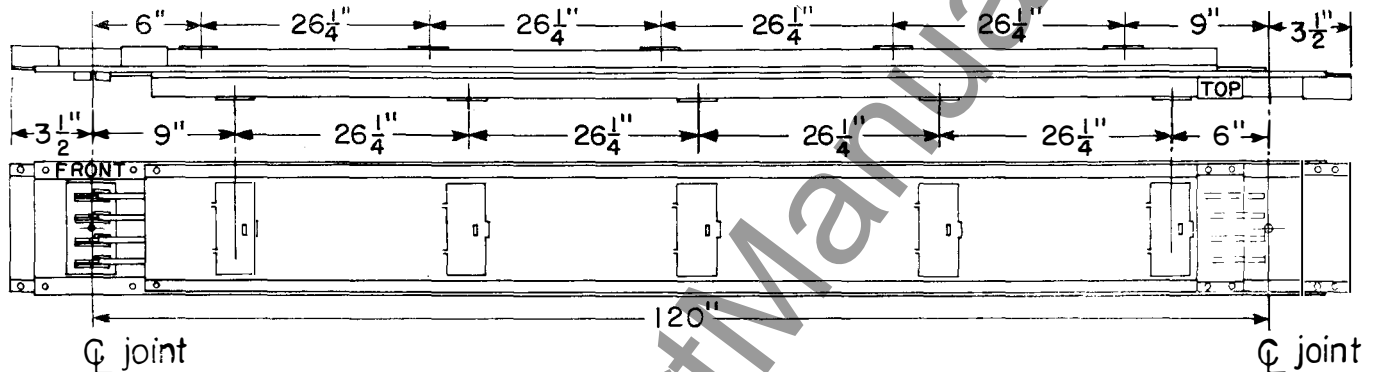

typical cross section views

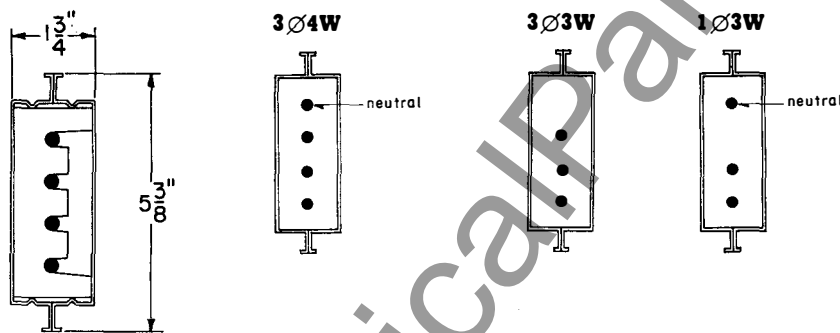

polarizing plug outlet

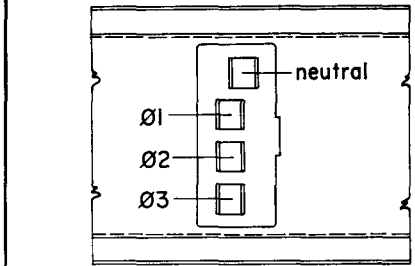

construction details

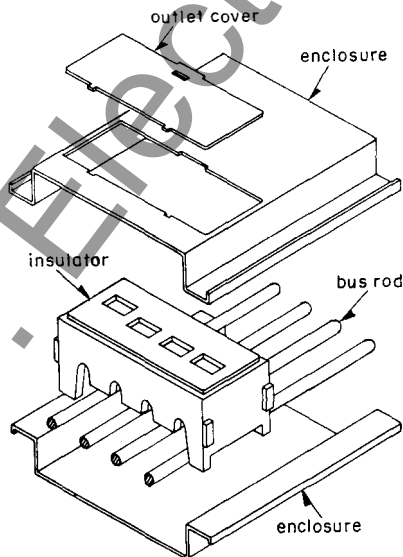

typical joint

Joints are designed for quick and easy assembly by simply snapping one section of 100 ampere bus duct to another and then securing them by running up the captive cover screws.

Electrical connection is made by special high pressure spring clips which firmly engage the conductors. The enclosure connection is made with a scarf lap type joint secured by captive cover screws.

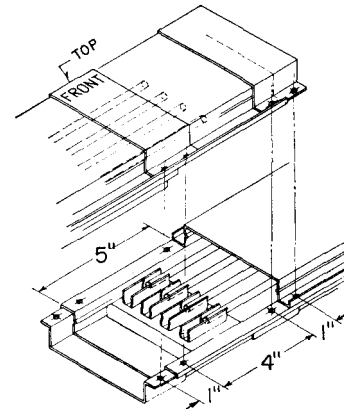



### fittings

key to relationship of fittings to straight lengths

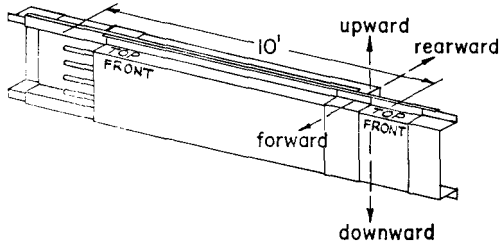

There are three basic fittings to meet every application need. These include elbows, tees and cable tap boxes. They are described in the following pages. When making field measurements and layouts, it should be remembered that dimensions of fittings are given from the centerline of the duct.

### elbows

Elbows are used to make 90° changes in the direction of busway runs. There are four types available with each leg of the elbow being 10 inches long. Flexible elbows are also available for special applications.

#### forward and rearward

forward

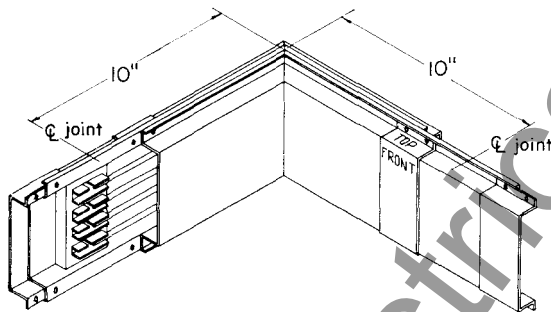

rearward

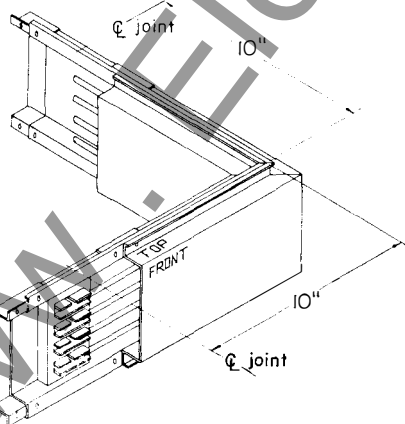

#### upward and downward

upward

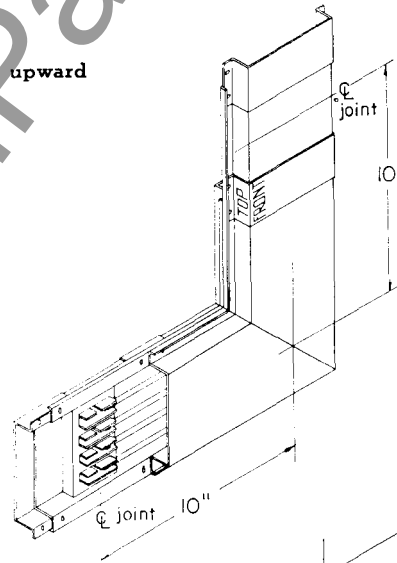

downward

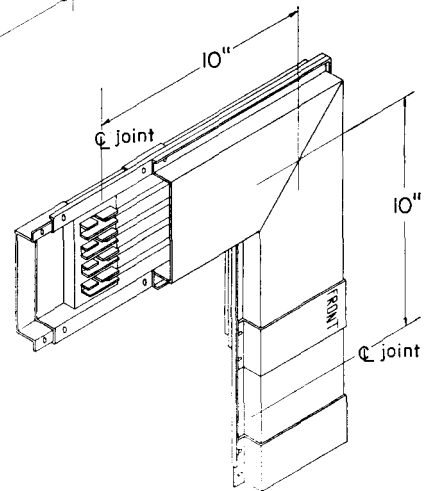

# 100 ampere bus duct

straight lengths, fittings, hangers

application data

30-566

page 5

## tees

Tees are busway fittings for making T connections to bus duct. The four standard tees are: forward, rearward, upward, and downward. Each leg of a tee is 10 inches long, measured from the centerline of the duct to the centerline of the joint.

### forward and rearward

forward

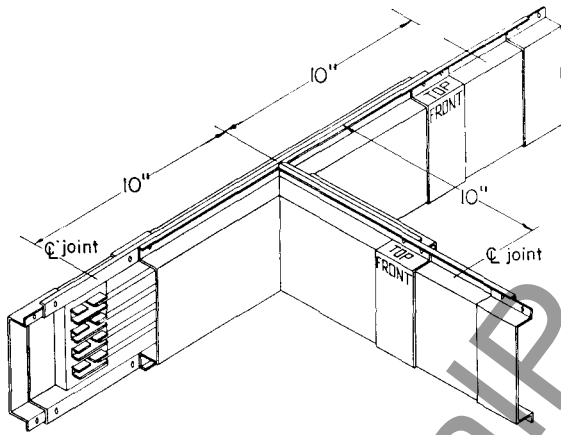

rearward

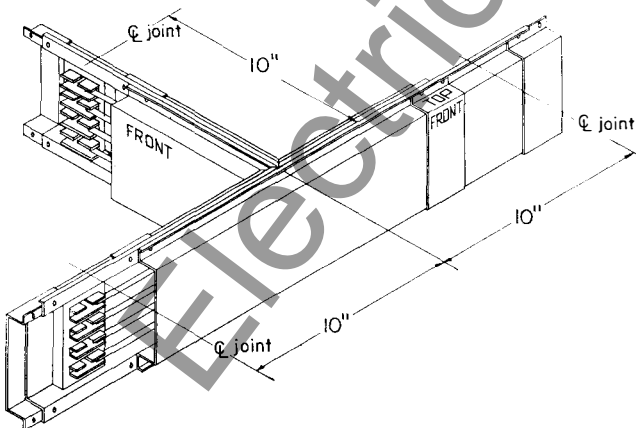

### upward and downward

upward

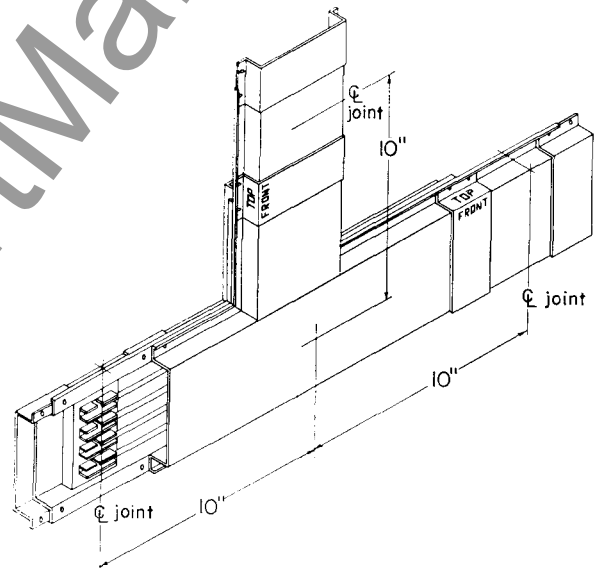

downward

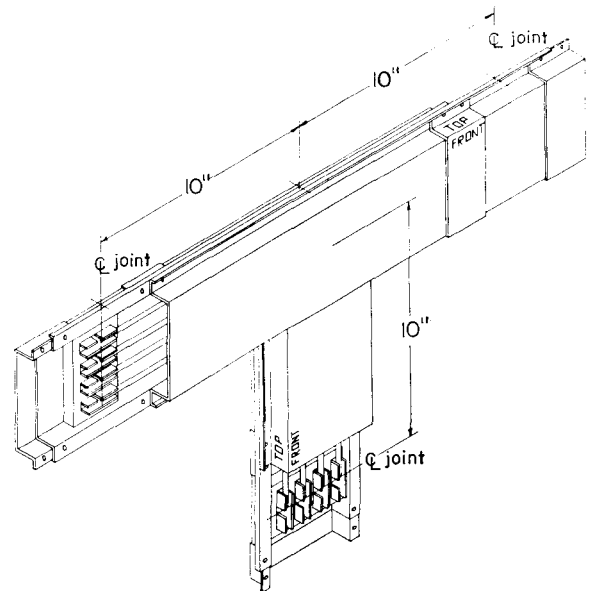

www.ElectricalPartManuals.com



**fittings**

**cable tap box**

The standard end cable tap box mounts at either the left or the right end of a bus duct straight length. Also available is a plug-in cable tap box with stabs for mounting at a plug outlet anywhere along the bus duct run. All tap boxes are rated 100 ampere and include lugs for accepting either copper or aluminum wire.

**end cable tap box • 100 ampere**  
right or left end

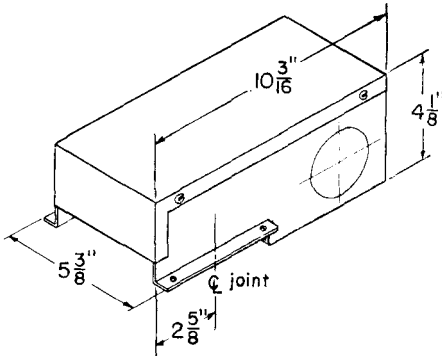

knockout sizes 1/4", 1/2" and 2"

**plug-in cable tap box**

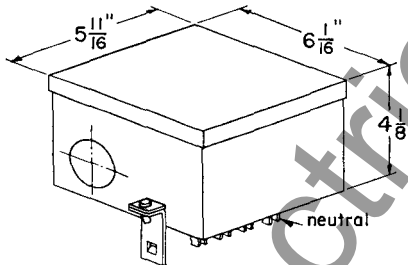

knockout sizes 3/4", 1", 1/4", 1/2" and 2"

**end closers**

End closers are used for closing off the end of a duct run. Where end cable tap boxes are used an end closer is not used. The effective length of an end closer is 4 inches.

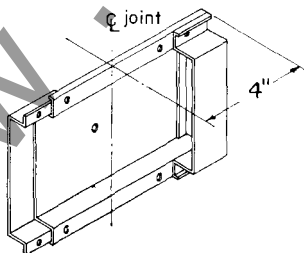

**hangers**

Hangers are included with the bus duct—one for each 10 foot section. Duct is suitable for supporting on 10 foot centers when mounted edgewise. The clip-on hanger grips the duct along the flanged edge of the duct enclosure. This hanger slips easily into place and is locked securely by a single bolt. The "C" clamp hanger is used for wall mounting or sway bracing. Both hangers hold the bus duct securely and safe from accidental dis-engagement through impact.

**typical hanger mounting**

"C" clamp

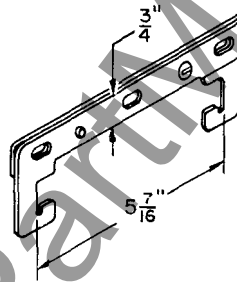

wall mounted

clip-on

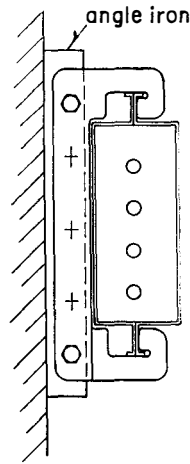
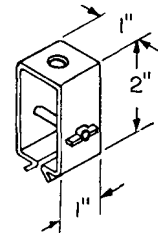

**external handle operating mechanism**

An external operating mechanism is available for the quicklag, E and EH circuit breakers for hook stick or chain operation.

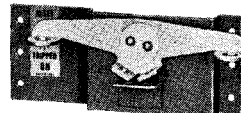

**plug-in devices**

Power take-offs are made by use of plug-in devices which plug-in through the insulated outlets of the busway enclosure and engage the bus conductors with stabs. Devices are available with overcurrent protection or without. Available are Quicklag P circuit breaker units for 50A 240V maximum service, "E" and "EH" circuit breakers for 100A maximum, 30A and 60A fusible units for 250 or 600 volts. Also available are 100 amp non-fusible non-switching plug-ins.

**circuit breaker**

**Quicklag breaker plug-in 50 ampere maximum, 240 volt**

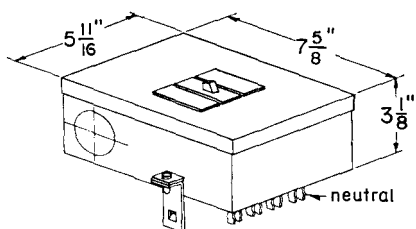

knockout sizes— $\frac{3}{4}$ " , 1" and  $1\frac{1}{4}$ "

**E and EH breaker plug-in 100 ampere maximum**

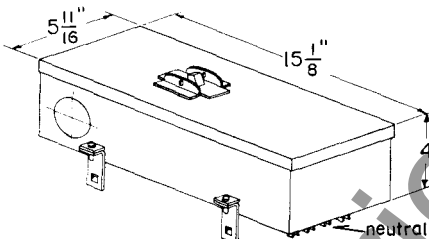

knockout sizes— $\frac{1}{2}$ " ,  $\frac{3}{4}$ " , 1" ,  $1\frac{1}{4}$ " ,  $1\frac{1}{2}$ " and 2"

**note:** Circuit breakers and enclosures are ordered and shipped separately for ease of installation and are shown assembled above for reference purposes only.

**non-fusible, non-switching plug-in unit**

**100 amp-600 volt**

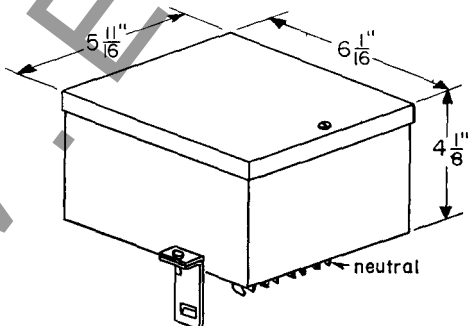

knockout sizes— $\frac{3}{4}$ " , 1" ,  $1\frac{1}{4}$ " ,  $1\frac{1}{2}$ " and 2"

**fusible and non-fusible**

**fusible plug-in unit, non-switching**

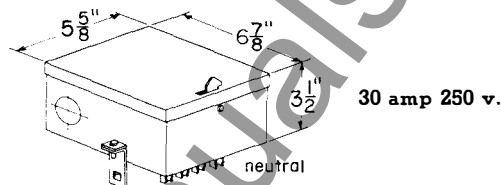

knockout sizes— $\frac{1}{2}$ " ,  $\frac{3}{4}$ " and 1"

30 amp 600 v.

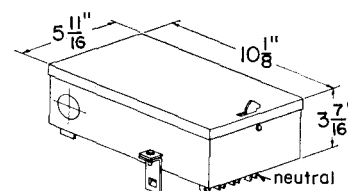

knockout sizes— $\frac{1}{2}$ " ,  $\frac{3}{4}$ " and 1"

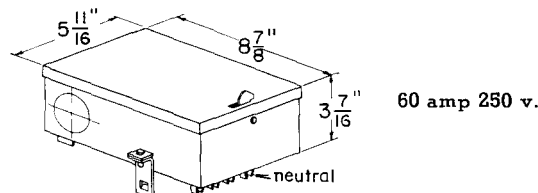

knockout sizes—1" ,  $1\frac{1}{4}$ " and  $1\frac{1}{2}$ "

60 amp 600 v.

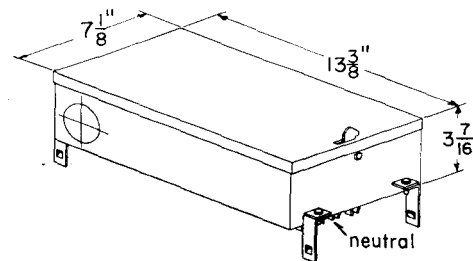

knockout sizes 1" ,  $1\frac{1}{4}$ " and  $1\frac{1}{2}$ "

**fusible plug-in unit, switching**

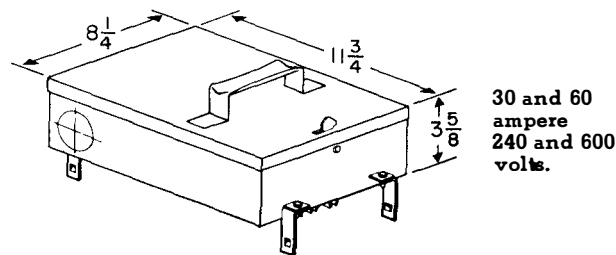

30 and 60 ampere 240 and 600 volts.

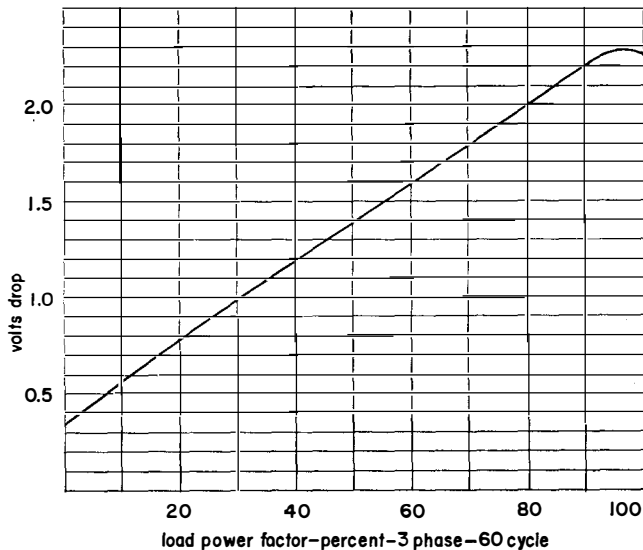
**voltage drop curve**

This graph gives the average line-to-line voltage drop per 100 feet at varying power factors. The curve is plotted from readings taken in actual tests and are applicable to line voltages above 100 volts. Voltage drop at values above or below full load current are proportional to the values shown. For example, voltage drop at one-half load will be one-half the values shown on the curve. The curve is based upon an evenly distributed load and the values are on a line to line basis.

**typical specifications****general**

The 100 ampere bus duct shall consist of aluminum bus conductors totally enclosed by and supported in a sheet steel housing. The complete installation shall be coordinated throughout, rigid in construction, of uniform size, and neat and symmetrical in appearance. The entire system shall be constructed using manufacturer's standard sections. As many sections as possible shall be ten foot lengths. Fittings shall be made in such a manner that no increase of enclosure size is required at the splice between adjoining sections. The bus duct shall be suitable for edgewise or vertical mounting.

The bus duct shall be listed by Underwriter's Laboratories and shall be as manufactured by Westinghouse or approved equal.

**conductors**

The conductors shall be fabricated from high strength, 55% minimum conductivity, round aluminum rods. Conductors are to be electrolytically plated their entire length with a successive plating process of zinc, copper and finally silver to assure maximum conductivity and minimum resistance where connections or taps are made. Conductor joints shall be made by means of boltless pressure clips which require no assembly or adjustment by the installer. The duct shall not be dependent upon the cover screws of the enclosure for maintaining the proper mechanical pressure to assure a good low resistance joint between electrical conductors of adjacent sections.

**enclosures**

The duct housing shall be made of 20 gauge steel, bonderized both inside and out and given one coat of medium light gray (ASA-49) baked on enamel. The enclosure shall include ten plug-in outlets in each ten foot length and shall include two plug-in outlets in each one foot length. All plug-in outlets shall be usable at the same time. Each plug-in outlet is to be enclosed by a removable steel knockout cover. The joint design shall be such that the use of loose hardware shall not be required. All hardware shall be completely captivated.

**supports**

Bus bars shall be firmly supported by molded insulators on alternate sides of the duct. Insulators shall be of the type through which it is possible to insert the stabs of a plug-in device in order to fully isolate the stabs as well as to afford extra protection in the event of stresses due to a fault. Insulators shall be spaced so as to allow mounting of plug-in units opposite to each other without interference.

**plug-in devices**

All plug-in units are to be polarized for maintaining correct phase orientation. Plug-in unit enclosures shall be made of 18 gauge steel or heavier, bonderized both inside and out and given one coat of medium light gray (ASA-49) baked on enamel. All plug-in devices shall include a means of securely fastening to the bus duct housing with a bolted clamping device.

**operating characteristics**

The bus duct shall have a continuous rating of 100 amperes with a voltage rating of 600 volts for 3 wire systems and 480 volts for 4 wire systems. The bus duct shall be so designed that, when operating at full capacity, no part shall exceed 55°C rise over a 30°C ambient temperature.